

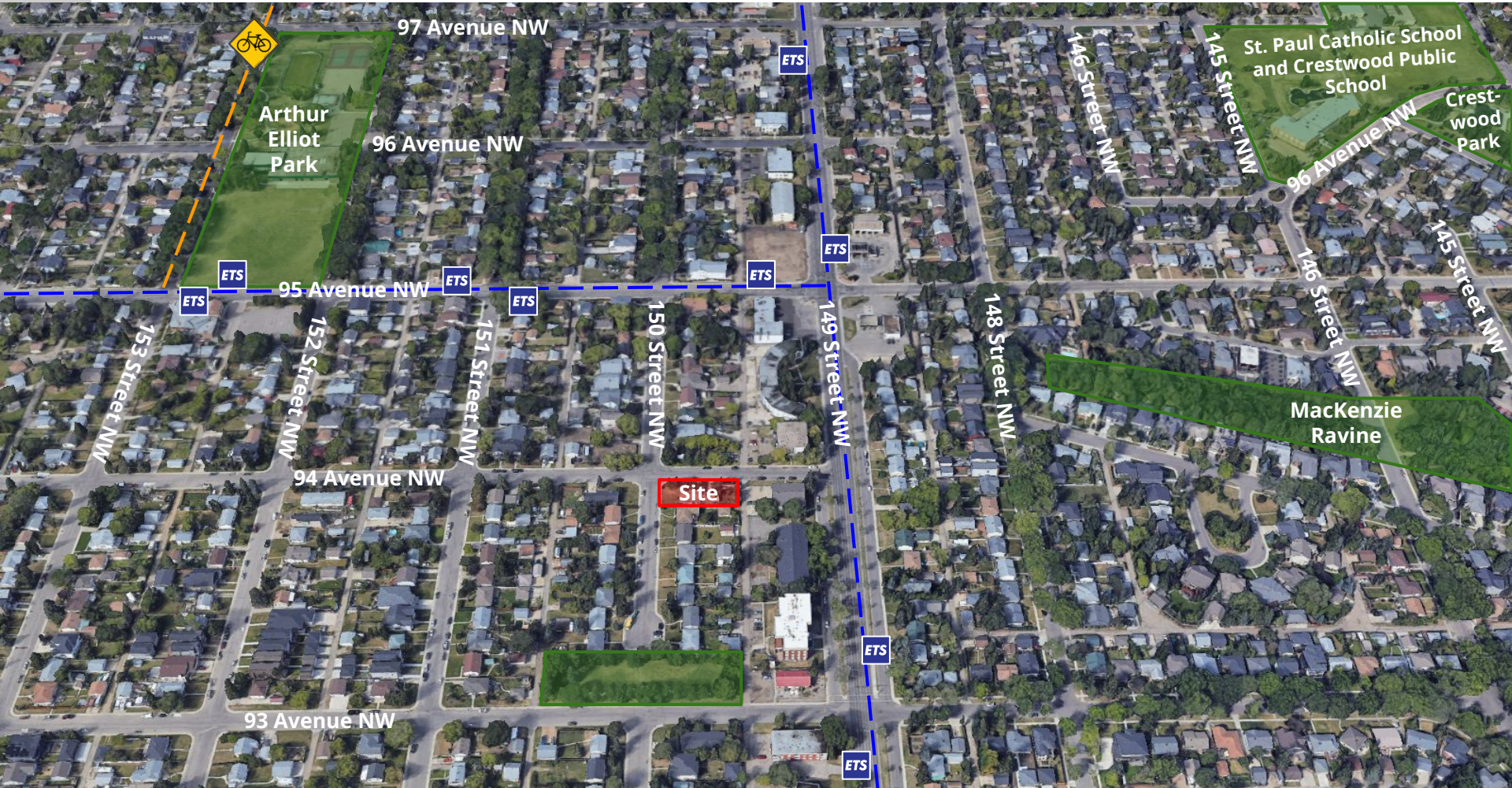

ITEM 3.12
CHARTER BYLAW 20283
SHERWOOD

DEVELOPMENT
SERVICES
October 4, 2022





Responses (2)

- Redevelopment will not result in affordable units
- The current building is in good condition
- Increased traffic will create safety concerns for children that play in the cul de sac
- Owned units are preferable to rental units



ADVANCED NOTICE
July 13, 2022



CITY WEBPAGE
July 19, 2022



SITE SIGNAGE
August 9, 2022



PUBLIC HEARING NOTICE
September 8, 2022



JOURNAL AD
September 16 and 24, 2022

PROPOSED ZONING

Current: RF1 + MNO

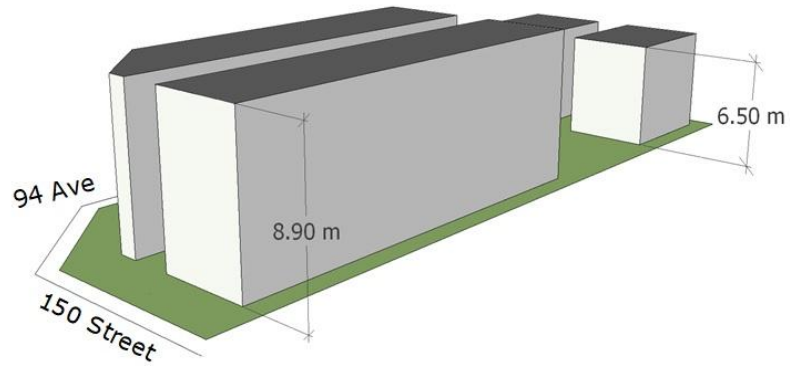
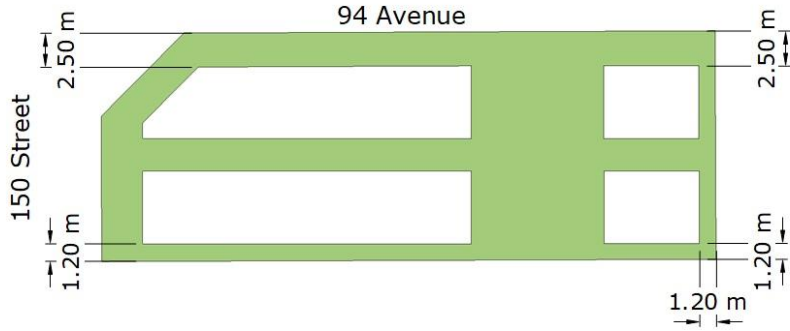

Proposed: RF3 + MNO

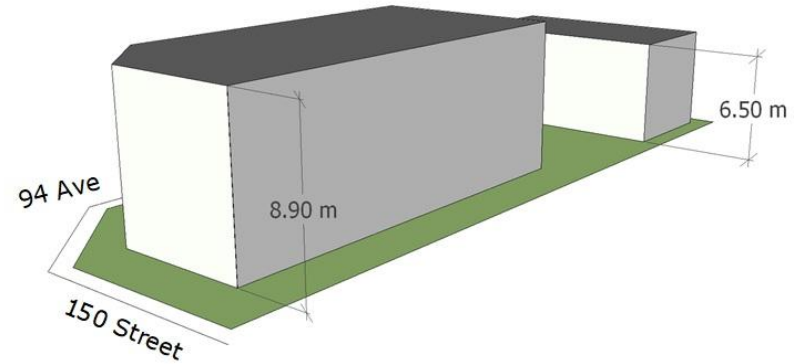
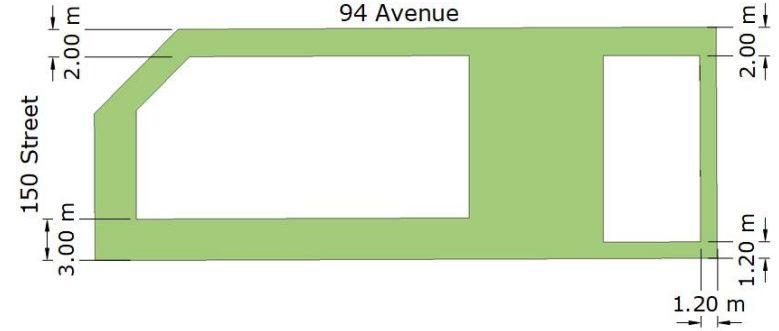



SITE VIEW

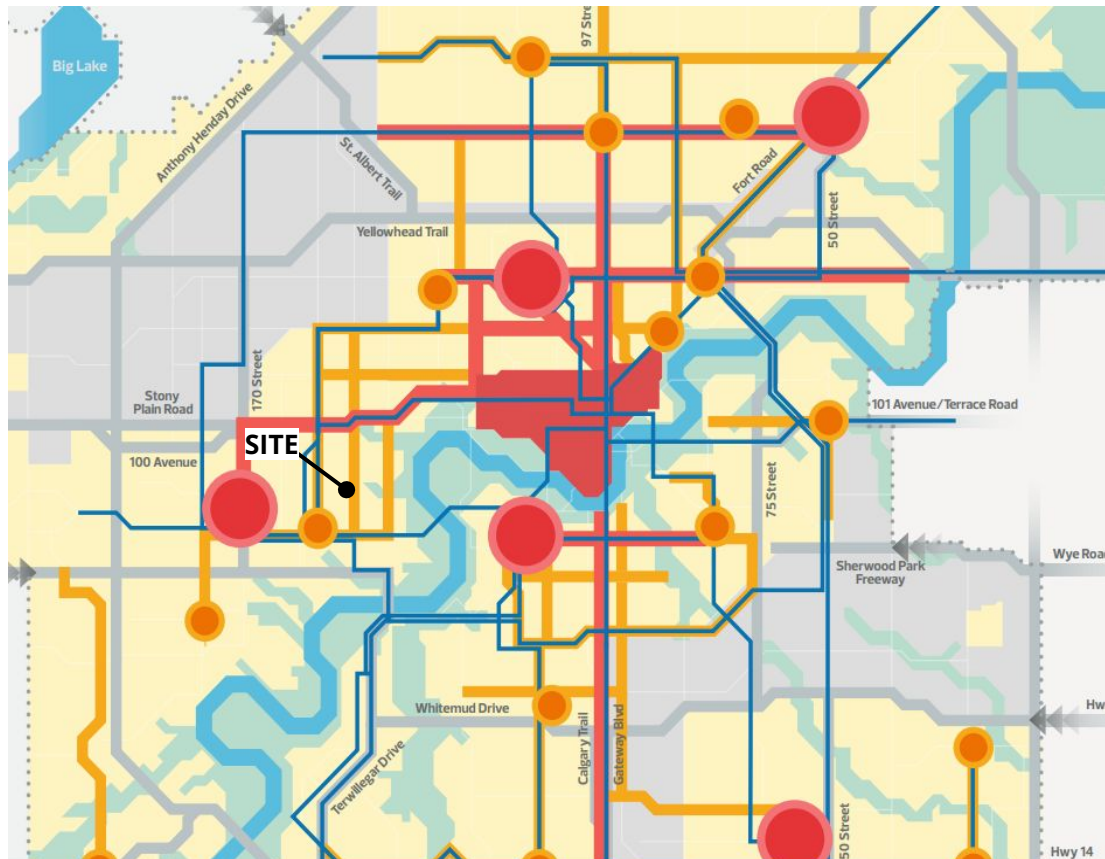

THE CITY PLAN



ADMINISTRATION'S RECOMMENDATION: **APPROVAL**