

**Aurum Road Environmental
Impact Assessment,
Edmonton, Alberta**

Final



Prepared for:
Aurum Industrial Development
Partnership



Prepared by:
Stantec Consulting Ltd.

April 2017
110219671

Table of Contents

1.0	INTRODUCTION	1.1
1.1	REGULATORY SETTING.....	1.1
1.2	PROJECT LOCATION.....	1.1
1.3	BACKGROUND	1.2
2.0	PROJECT DESCRIPTION	2.1
2.1	PROJECT COMPONENTS.....	2.1
2.1.1	Aurum Road Crossing of Clover Bar Ravine	2.1
2.1.2	Wildlife Passage	2.1
2.1.3	Creek Realignment	2.2
2.1.4	Aurum Road Crossing of the western dry ravine.....	2.2
2.2	PROJECT ACTIVITIES.....	2.3
2.2.1	Construction.....	2.3
2.2.1.1	Vegetation Clearing	2.3
2.2.1.2	Creation of Construction Access.....	2.3
2.2.1.3	Creek Isolation and Pump Around	2.3
2.2.1.4	Arch Culvert Installation.....	2.4
2.2.1.5	Backfill and Grading	2.4
2.2.1.6	Creek Realignment and Wildlife Passage.....	2.5
2.2.1.7	Construction of Aurum Road.....	2.5
2.2.1.8	Reclamation and Revegetation	2.5
2.2.2	Operation	2.6
2.2.2.1	Daily Use of Aurum Road.....	2.6
2.2.2.2	Pre- Final Acceptance Certificate Maintenance Period	2.6
2.2.2.3	Wildlife Passage Maintenance Activities	2.6
2.3	PROJECT SCHEDULE.....	2.7
2.4	REGULATORY ENGAGEMENT AND CONSULTATION	2.7
2.5	PUBLIC ENGAGEMENT AND CONSULTATION	2.7
2.6	PROJECT ALTERNATIVES	2.8
2.6.1	Options Considered During the Detailed Design Process	2.9
2.6.1.1	Option 1: Preliminary Design Package.....	2.9
2.6.1.2	Option 2: Realigned Arch Culvert (The Proposed Option).....	2.9
2.6.2	Rationale for Choosing Option 2.....	2.9
3.0	SCOPE OF THE ASSESSMENT	3.1
3.1	SELECTION OF VALUED COMPONENTS.....	3.1
3.2	SPATIAL AND TEMPORAL BOUNDARIES	3.1
3.3	REGULATORY AND POLICY SETTING	3.2
4.0	BASELINE CONDITIONS.....	4.1
4.1	SOCIOECONOMIC SETTING.....	4.1

4.1.1	Historic and Current Land Use	4.1
4.1.2	Adjacent Land	4.1
4.2	PHYSICAL ENVIRONMENT	4.1
4.2.1	Viewscape	4.1
4.2.2	Geology, Topography and Soils	4.1
4.2.3	Groundwater and Surface Water	4.2
4.2.4	Fish and Fish Habitat	4.3
4.2.5	Vegetation	4.4
4.2.6	Wildlife	4.4
4.2.7	Historical Resources	4.6
	4.2.7.1 Archaeological Overview	4.6
	4.2.7.2 Palaeontological Overview	4.7
5.0	ASSESSMENT OF POTENTIAL ENVIRONMENTAL EFFECTS ON VALUED COMPONENTS	5.1
5.1	VIEWSCAPE	5.1
5.1.1	Potential Effects, Pathways, and Measurable Parameters	5.1
5.1.2	Criteria for Characterizing Residual Effects	5.1
5.1.3	Project Interactions with Viewscape	5.2
5.1.4	Assessment Techniques	5.3
5.1.5	Assessment of Change in Viewscape	5.3
	5.1.5.1 Project Pathways	5.3
	5.1.5.2 Mitigation Measures	5.3
	5.1.5.3 Residual Effects	5.4
5.1.6	Summary of Residual Effects on Viewscape	5.4
5.2	SURFACE WATER	5.4
5.2.1	Potential Effects, Pathways, and Measurable Parameters	5.4
5.2.2	Criteria for Characterizing Residual Effects	5.5
5.2.3	Project Interactions with Surface Water	5.6
5.2.4	Assessment Techniques	5.7
5.2.5	Assessment of Change in Sediment Load and Water Quality	5.7
	5.2.5.1 Project Pathways	5.7
	5.2.5.2 Mitigation Measures	5.7
	5.2.5.3 Residual Effects	5.8
5.2.6	Assessment of Change in Hydraulics of Clover Bar Creek	5.8
	5.2.6.1 Project Pathways	5.8
	5.2.6.2 Mitigation Measures	5.10
	5.2.6.3 Residual Effects	5.10
5.2.7	Summary of Residual Effects on Surface Water	5.12
5.3	FISH AND FISH HABITAT	5.12
5.3.1	Potential Effects, Pathways, and Measurable Parameters	5.12
5.3.2	Criteria for Characterizing Residual Effects	5.13
5.3.3	Project Interactions with Fisheries and Fish Habitat	5.14
5.3.4	Assessment Techniques	5.15
5.3.5	Assessment of Change of Fish Habitat	5.15

	5.3.5.1	Project Pathways	5.15
	5.3.5.2	Mitigation Measures	5.15
	5.3.5.3	Residual Effects	5.16
5.3.6		Assessment of Change in Fish Movement, Migration and Fish Passage.....	5.16
	5.3.6.1	Project Pathways	5.16
	5.3.6.2	Mitigation Measures	5.17
	5.3.6.3	Residual Effects	5.17
5.3.7		Assessment of Change in Fish Mortality.....	5.18
	5.3.7.1	Project Pathways	5.18
	5.3.7.2	Mitigation Measures	5.18
	5.3.7.3	Residual Effects	5.18
5.3.8		Summary of Residual Effects on Fisheries and Fish Habitat	5.19
5.4		VEGETATION	5.19
5.4.1		Potential Effects, Pathways, and Measurable Parameters	5.19
5.4.2		Criteria for Characterizing Residual Effects	5.20
5.4.3		Project Interactions with Vegetation.....	5.21
5.4.4		Assessment Techniques	5.22
5.4.5		Assessment of Change in Plant Community Diversity	5.22
	5.4.5.1	Project Pathways	5.22
	5.4.5.2	Mitigation Measures.....	5.22
	5.4.5.3	Residual Effects	5.22
5.4.6		Summary of Residual Effects on Vegetation	5.23
5.5		WILDLIFE	5.23
5.5.1		Potential Effects, Pathways, and Measurable Parameters	5.23
5.5.2		Criteria for Characterizing Residual Effects	5.24
5.5.3		Project Interactions with Wildlife.....	5.25
5.5.4		Assessment Techniques	5.26
5.5.5		Assessment of Change in Habitat.....	5.26
	5.5.5.1	Project Pathways	5.26
	5.5.5.2	Mitigation Measures.....	5.26
	5.5.5.3	Residual Effects	5.26
5.5.6		Assessment of Change in Mortality Risk.....	5.27
	5.5.6.1	Project Pathways	5.27
	5.5.6.2	Mitigation Measures.....	5.27
	5.5.6.3	Residual Effects	5.28
5.5.7		Assessment of Change in Movement.....	5.28
	5.5.7.1	Project Pathways	5.28
	5.5.7.2	Mitigation Measures.....	5.28
	5.5.7.3	Residual Effects	5.29
5.5.8		Summary of Residual Effects on Wildlife	5.29
5.6		HISTORICAL RESOURCES.....	5.30
5.6.1		Potential Effects, Pathways, and Measurable Parameters	5.30
5.6.2		Criteria for Characterizing Residual Effects	5.30

5.6.3	Project Interactions with Archaeological and Historical Resources.....	5.31
5.6.4	Analytical Methods.....	5.32
5.6.5	Existing Conditions.....	5.32
5.6.5.1	Project Pathways.....	5.33
5.6.5.2	Mitigation Measures.....	5.33
5.6.5.3	Residual Effects.....	5.33
6.0	SUMMARY OF ASSESSMENT OF POTENTIAL ENVIRONMENTAL EFFECTS.....	6.1
7.0	MONITORING.....	7.1
8.0	LIMITATIONS AND QUALIFICATIONS.....	8.1
9.0	REFERENCES.....	9.1

LIST OF TABLES

Table 1	Regulatory Engagement and Consultation Record.....	2.7
Table 2	Applicable Legislation.....	3.2
Table 3	Potential Effects, Effects Pathways, and Measurable Parameters for Viewscape.....	5.1
Table 4	Residual Effect Characterization Definitions for Viewscape.....	5.1
Table 5	Project Environment Interactions with Viewscape.....	5.2
Table 6	Residual Effect Characterizations for Viewscape.....	5.4
Table 7	Potential Effects, Effects Pathways, and Measurable Parameters for Surface Water.....	5.5
Table 8	Residual Effect Characterization Definitions for Surface Water.....	5.5
Table 9	Project Environment Interactions with Surface Water.....	5.6
Table 10	Natural Channel and Proposed Realigned Channel Hydraulics.....	5.8
Table 11	Residual Effect Characterizations for Surface Water.....	5.12
Table 12	Potential Effects, Effects Pathways, and Measurable Parameters for Fisheries and Fish Habitat.....	5.13
Table 13	Residual Effect Characterization Definitions for Fisheries and Fish Habitat.....	5.13
Table 14	Project Environment Interactions with Fisheries and Fish Habitat.....	5.14
Table 15	Residual Effect Characterizations for Fisheries and Fish Habitat.....	5.19
Table 16	Potential Effects, Effects Pathways, and Measurable Parameters for Vegetation.....	5.20
Table 17	Residual Effect Characterization Definitions for Vegetation.....	5.20
Table 18	Project Environment Interactions with Vegetation.....	5.21
Table 19	Residual Effect Characterizations for Vegetation.....	5.23
Table 20	Potential Effects, Effects Pathways, and Measurable Parameters for Wildlife.....	5.23
Table 21	Residual Effect Characterization Definitions for Wildlife.....	5.24
Table 22	Project Environment Interactions with Wildlife.....	5.25

Table 23	Residual Effect Characterizations for Wildlife	5.29
Table 24	Potential Effects, Effects Pathways, and Measurable Parameters for Historical Resources.....	5.30
Table 25	Project Environment Interactions with Historical Resources	5.31
Table 26	Summary of Potential Environmental Effects Assessment.....	6.2

LIST OF FIGURES

Figure 1	Local Assessment Area and Project Disturbance Areas.....	1.3
Figure 2	Project Overview	1.4

LIST OF APPENDICES

APPENDIX A	FIGURES	A.1
APPENDIX B	VEGETATION TECHNICAL DATA REPORT	B.1
APPENDIX C	WILDLIFE TECHNICAL DATA REPORT	C.1
APPENDIX D	FISH AND FISH HABITAT ASSESSMENT.....	D.1
APPENDIX E	GEOTECHNICAL REPORT.....	E.1
APPENDIX F	EROSION AND SEDIMENT CONTROL PLAN	F.1
APPENDIX G	CLOVER BAR CREEK CROSSING AT AURUM ROAD: EVALUATION OF WILDLIFE PASSAGE	G.1
APPENDIX H	GEOMORPHOLOGY - GEOTECHNICAL TECHNICAL MEMO	H.1

1.0 INTRODUCTION

Aurum Industrial Development Partnership (the Proponent) has retained Stantec Consulting Ltd. (Stantec) to complete an Environmental Impact Assessment (EIA) on Aurum Road (the Project). The Project, as defined for the EIA, includes only proposed disturbance within the boundaries of the North Saskatchewan River Valley (NSRV) a nationally significant natural area (Geowest 1993) and a major ecological corridor that traverses the Province of Alberta (ESRD 2015). These project disturbance areas (PDAs), as shown on Figure 1 as PDA1 and PDA2 are 2.8 and 0.3 ha respectively. The PDAs represent the intersection of the top of bank survey line for the NSRV and the temporary and permanent disturbance of the Project. Any disturbance for Aurum Road within the tablelands, the land above the legal top of bank survey line for the NSRV, are not included in the EIA. As part of the EIA, biophysical assessments were completed within the local assessment area (LAA) for the Project, the potential area that the Project effects could be reasonably measured outside of the PDAs and based on the confinements of the surrounding development.

Major components of the Project include the following:

- Construction of Aurum Road over Clover Bar Creek (the creek)
- Construction of a wildlife passage under Aurum Road
- Realignment of the creek to accommodate Aurum Road and incorporate a wildlife passage
- Construction of Aurum Road over a dry ravine on the western side of SE-21-53-23-W4M

Components of the Project are discussed in detail in Section 2.0.

1.1 REGULATORY SETTING

This EIA was conducted in accordance with the requirements of the North Saskatchewan River Valley Area Redevelopment Plan (NSRVARP, Bylaw 7188, City of Edmonton 2014) and the Guide to Environmental Review Requirements on the North Saskatchewan River Valley and Ravine System (City of Edmonton 2000).

1.2 PROJECT LOCATION

The Project is located within a regional setting that is largely industrial development, south of the North Saskatchewan River (NSR) as shown on Figure 2 Project Overview. Locally, the Project is in the Aurum Industrial Business Park in the City of Edmonton, Alberta. The LAA is a mixture of Industrial Business (IB) zoned land, Environmental Reserve (ER), Alberta Infrastructure pipeline right-of-way (ROW), and an ATCO-owned substation. Tablelands within the LAA are currently being used as agricultural land. The LAA is bordered to the north by the Provincial crown-owned pipeline ROW, to the east by 17 Street NE, to the south by 127 Avenue NE, and to the west by 9 Street NE and the transportation utility corridor (TUC). The Creek flows northwest through the

Introduction
April 2017

deep and steep-sided Clover Bar Ravine (the ravine), which originates in a stormwater management pond within the interchange of Highway 16 and Range Road 232, and overland northeast through the Alberta Infrastructure pipeline ROW ultimately to the NSR.

The Project crosses over a dry ravine on the western side of the LAA, a portion of NSRV that extends into the pipeline ROW.

1.3 BACKGROUND

The Aurum Industrial Business Park (the Industrial Park), which is currently accessed from Highway 16 via 17 Street NE, has been under development since approximately 2005. As development of the Industrial Park has continued, personnel and traffic associated with businesses within the Industrial Park have increased. Traffic congestion on 17 Street NE has become a regular occurrence, and is exacerbated by the Canadian National (CN) and Canadian Pacific (CP) train tracks that cross 17 Street NE between 127 Avenue NE and Highway 16. Trains on these tracks cause traffic backlogs, while employees who work within the Industrial Park wait to cross the tracks to and/or from their places of business. Aurum Road, which will eventually connect Anthony Henday Drive (Highway 216) (the Henday) to Highway 21, is currently constructed between 17 Street NE and Range Road 232, and between the Henday and 9 Street NE. Construction of Aurum Road that passes through SE-21-53-23-W4M is required to complete the connection to Secondary Highway 21. While the Industrial Park only requires a two-lane roadway to service it, the roadway will ultimately be expanded to six lanes to facilitate the increased traffic this roadway will receive as a bypass route between the Henday and Highway 21. This will bypass both sets of train tracks on 17 Street NE, thereby creating an easily accessible and major route through the Industrial Park.

In 2016, numerous businesses within the Industrial Park approached City of Edmonton Council and requested that the Aurum Road connection between 17 Street NE and 9 Street NE be completed to alleviate the traffic congestion in the Industrial Park. The Project was placed on a priority list for the City of Edmonton, whereby they initiated the preliminary design options for Aurum Road and the ravine.

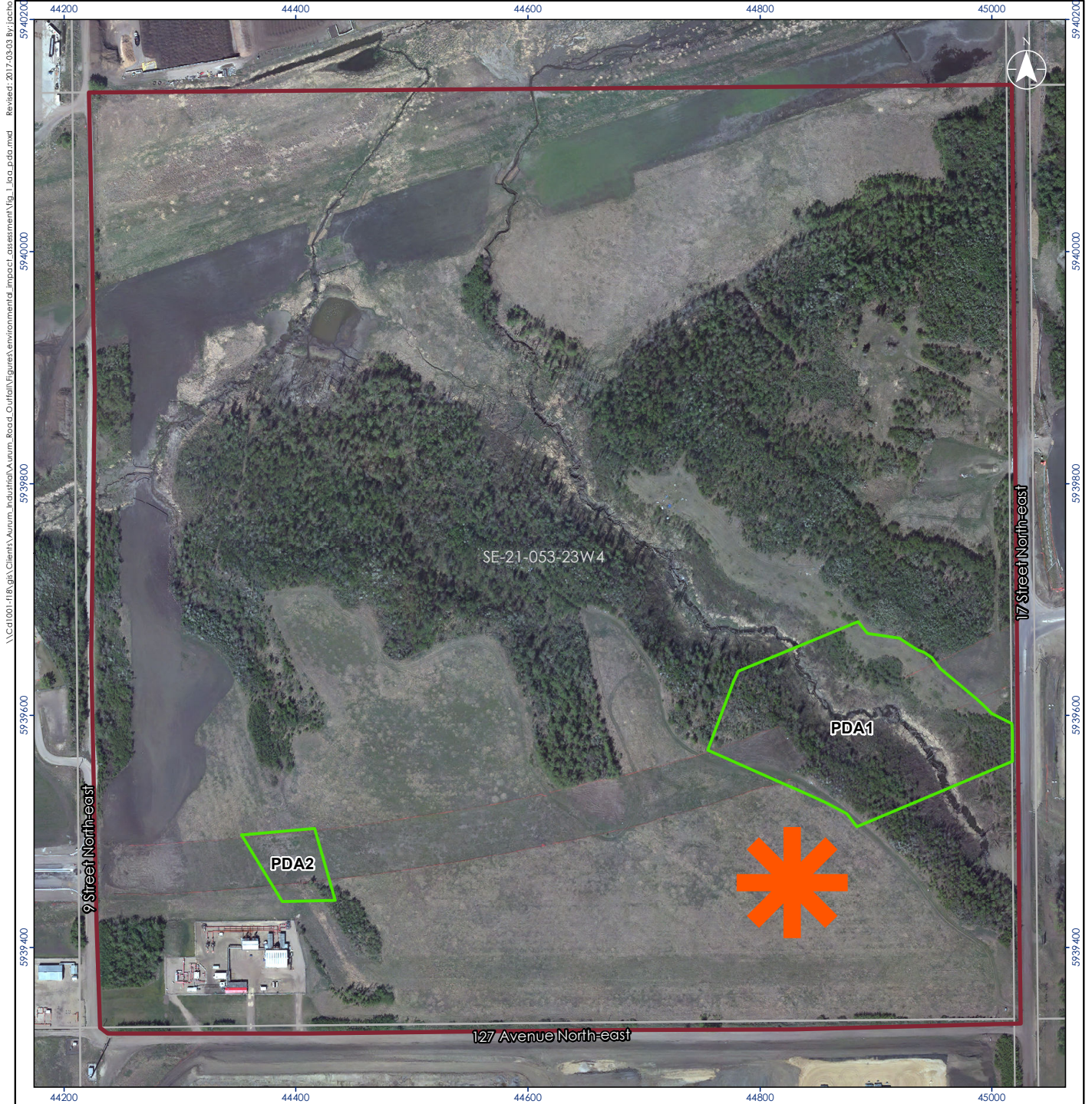

\\Cd1001-118\gis\Clients\Aurum_Industrial\Aurum_Road_Outfall\Figures\environmental_impact_assessment\Fig_1_10a_pda.mxd Revised: 2017-03-03 By: jachs

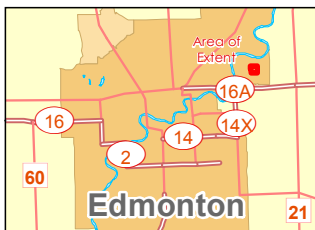

- Local Assessment Area
- Project Disturbance Areas
- ✱ Proposed Staging Area
- Quarter Section

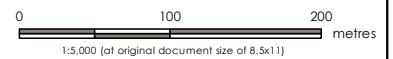

Project Location 110219671
 12704-17 Street NE Prepared by JC on 2016-12-19
 SE/4 21-053-23 W4M Quality Review by MK on 2016-12-19
 Edmonton, Alberta Approved by GH on 2017-01-17

Client/Project
 Aurum Industrial Development Partnership
 Aurum Road Environmental Impact Assessment

Figure No.
1

**Local Assessment Area and
 Project Disturbance Areas**

- Notes**
1. Coordinate System: NAD 1983 3TM 114
 2. Base features: Geogratis, ©Department of Natural Resources Canada. All rights reserved.
 3. Imagery: City of Edmonton Transportation, 2015

Disclaimer: Stantec assumes no responsibility for data supplied in electronic format. The recipient accepts full responsibility for verifying the accuracy and completeness of the data. The recipient releases Stantec, its officers, employees, consultants and agents, from any and all claims arising in any way from the content or provision of the data.

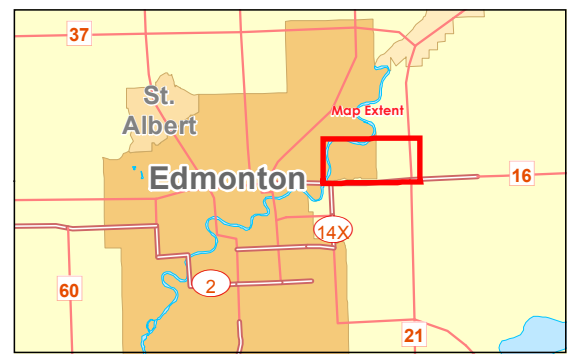
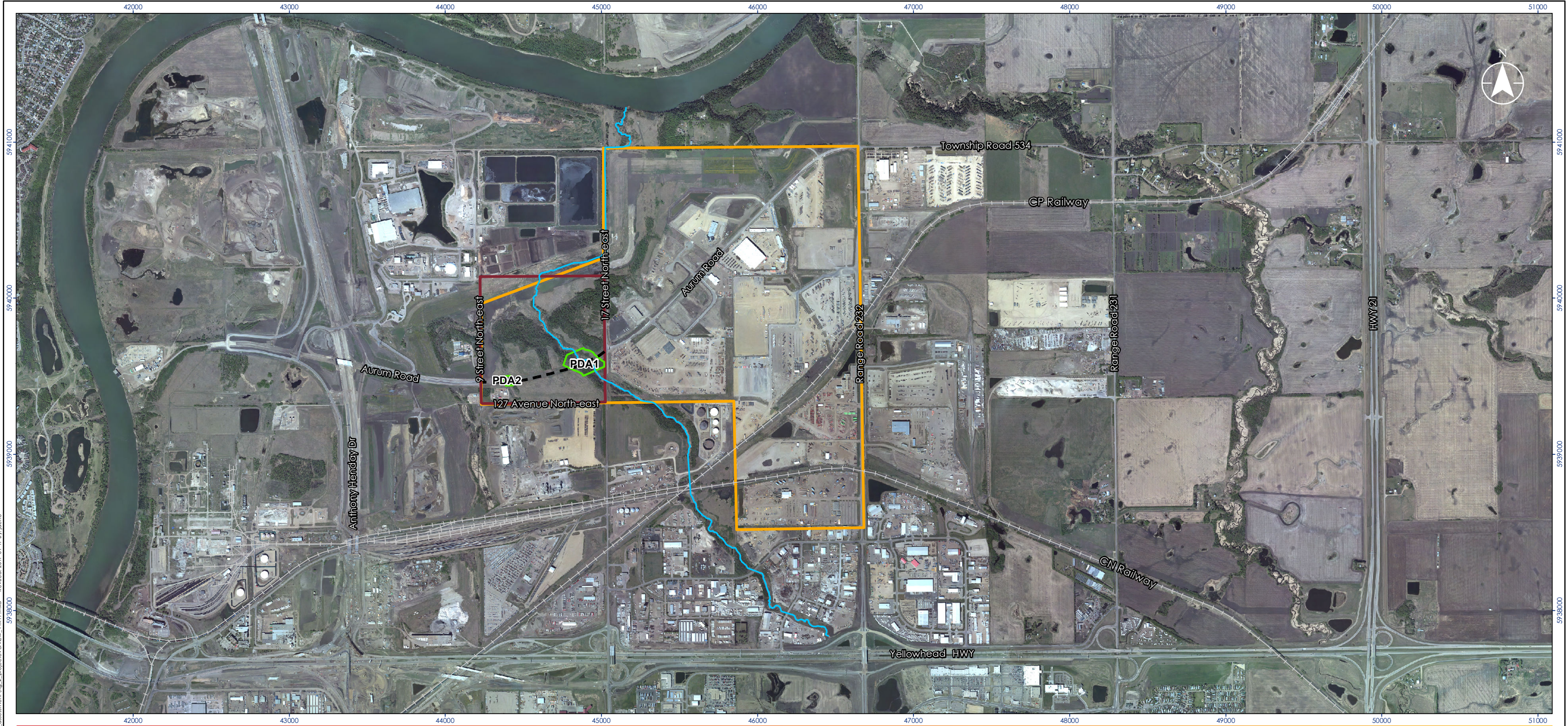

- Proposed Road
- Aurum Energy Park
- Local Assessment Area
- Project Disturbance Areas
- Clover Bar Creek
- Railway
- Quarter Section

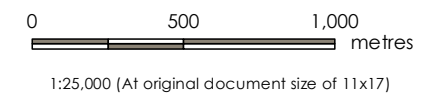

Project Location
 12704-17 Street NE
 SE¼ 21-053-23 W4M
 Edmonton, Alberta

110291671
 Prepared by JC on 2016-12-19
 Quality Review by MK on 2016-12-19
 Approved by GH on 2017-01-17

Client/Project
 Aurum Industrial Development Partnership
 Aurum Road Environmental Impact Assessment

Figure No.
2

Title
Project Overview

Notes

1. Coordinate System: NAD 1983 3TM 114
2. Base features: Geogratis, ©Department of Natural Resources Canada, All rights reserved., GeoLOGIC Systems Ltd. 2015.
3. Imagery: City of Edmonton Transportation Department, 2015

Disclaimer: Stantec assumes no responsibility for data supplied in electronic format. The recipient accepts full responsibility for verifying the accuracy and completeness of the data. The recipient releases Stantec, its officers, employees, consultants and agents, from any and all claims arising in any way from the content or provision of the data.

2.0 PROJECT DESCRIPTION

The following sections will provide a detailed description of the Project and how it was decided upon.

2.1 PROJECT COMPONENTS

The major components of the Project are listed and described below:

- Aurum Road crossing of Clover Bar Ravine
- Wildlife passage
- Creek realignment
- Aurum Road crossing of the western dry ravine

2.1.1 Aurum Road Crossing of Clover Bar Ravine

Aurum Road will cross the ravine, a deep and steep-sided ravine generally east to west. The Aurum Road crossing will be approximately 200 m across the ravine and will cross at an elevation of 648 m, which is equivalent to the top of bank for each side of the ravine. The road will ultimately be a six lane arterial roadway, with three lanes in each direction, necessary to relieve congestion and traffic pressures on the Yellowhead Highway 1. However at this time, only two lanes (with a turning lane) will be paved. The remaining lanes will be built at a later date; the area for these lanes will be seeded for grass and will tie into the stormwater management system for the Aurum Industrial Development area that will be built on the tablelands.

Utility lines will be built into the subsurface of the roadway, overlaying the arch culvert, including water lines and sewer lines, gas services, power lines and telephone lines.

2.1.2 Wildlife Passage

A wildlife passage below Aurum Road will be facilitated by the installation of an arch culvert at the bottom of the ravine. Design was informed by the Clove Bar Creek Crossing at Aurum Road: Evaluation of Wildlife Passage (see Appendix G). The arch culvert will be a bottomless, multi-plate, concrete arch structure 21.5 m wide, 8 m in height and 67 m in length. The arch culvert will be supported by a foundation set onto geotechnical H-pile, driven deep into the competent bedrock material below the ravine.

The main, large mammal passage will be on the east side of the creek as a 9 - 12 m wide bench, with areas built into the bench for small mammal cover (through the use of a continuous brush pile along the edge of the culvert and ground; brush, stone and small-diameter woody debris, small diameter (300 mm) pipe covered with mounded topsoil and sheltered by small woody debris). A smaller bench on the west side of the crossing will be 1.5 – 4 m wide for small animal passage. The creek will be lined with stepped, thick and wide boulders, flat on the top and bottom faces, that will be easy for animals to step on and used to exit the creek water.

Project Description
April 2017

Appendix A Figures, Creek Realignment Sections have been included to illustrate the wildlife passage.

2.1.3 Creek Realignment

The creek is a southern tributary of the NSR and is part of a watershed area that extends from Strathcona County to the eastern part of the City of Edmonton. The creek flows northwest through the deep and steep-sided ravine, overland northeastwardly through the pipeline ROW and ultimately to the NSR. A portion of the creek will be realigned within PDA1 in order to accommodate Aurum Road and a wildlife passage.

The creek will be shortened from 174 m to 103 m in length through the PDA1 for a total loss of 690 m² of area. The realignment will consist of a sinuous length of creek that is approximately 4.5 m wide at its base and has been designed to the standard 100-year storm event but will accommodate a 200-year event within the freeboard area. The creek base will consist of disturbed clay overlain by 200 mm depth of 75 mm crushed rock and 50 mm sand, overlain by 75 mm depth of 40 mm rainbow rock with 25 mm sand. The length of the creek will be armoured with landscape fabric, 400 – 600 mm thick, by 600 - 800 mm wide, by 1 – 2 m long stabilization boulders stepped to the 1:100 year flood line. The creek channel will have an incised channel 1 m wide with sloped sides, 4 deep pools, riffles consisting of river rock placed throughout the creek and root wads. Aurum creek realignment design figures are included in Appendix A Figures.

Design of the creek realignment was informed by the geomorphology, geotechnical stability and hydraulic modeling completed during the design process to be consistent with flow rates of the creek after construction as they were prior to realignment. Maintaining flow rates within the creek is critical to the function of the watershed the creek is part of the design. For more information on the creek realignment and channel hydraulics, see Section 5.2.6 and Appendix H Geomorphology – Geotechnical Technical Memo.

2.1.4 Aurum Road Crossing of the western dry ravine

Aurum Road will cross a second ravine of the NSR, within the western portion of SE-21-53-23-W4M. The top of bank for this dry ravine extends almost to 127 Ave and currently receives runoff from 127 Ave roadway and overland agricultural areas within this section of the LAA. The ravine will be crossed perpendicular to its extent by Aurum Road. Flow of surface water runoff for this area will be conveyed under Aurum Road via a flared end pipe, which will tie into a Stormwater Management Facility (SWMF) built for the Industrial park within the tablelands. The details for the flared end pipe and SWMF for the Industrial park, including Aurum Road, will be submitted as part of the Aurum Industrial Development Outfall ESR at a later date. Location of the Aurum Road crossing of the western dry ravine, as defined as the PDA2, is shown on Figure 1.

2.2 PROJECT ACTIVITIES

Project activities fall under two phases: construction and operation. The activities have been listed sequentially in the order they will occur.

2.2.1 Construction

Construction activities include the following:

- Vegetation clearing
- Creation of construction access
- Creek isolation and pump around
- Arch Culvert Installation
- Backfill and grading
- Creek realignment and wildlife passage
- Construction of Aurum Road
- Reclamation and revegetation

2.2.1.1 Vegetation Clearing

Vegetation clearing (site clearing) will include removal of all trees and plants from both PDA1 and PDA2 for a total of 2.8 and 0.3 ha respectively, based on the permanent footprint and temporary work space. Clearing will be done using both mechanical mulcher and hand tools and will occur outside of the breeding bird season, to the extent possible based on Project approval.

2.2.1.2 Creation of Construction Access

Several accesses were created for the initial geotechnical drilling program, through the removal of large trees, brush and understory. Stripping and grading was also completed to provide safe access to steep slope areas and to create platforms for the drilling rig, however these access routes are not sufficient for heavy equipment and trucks (e.g., excavators, cement trucks, cranes). These accesses will be utilized, modified as necessary and once vegetation clearing of all permanent and temporary workspace is completed, new accesses will be created for construction of the Project. Slopes will be modified as necessary during construction access to allow for safe passage of the equipment to the bottom of the ravine.

2.2.1.3 Creek Isolation and Pump Around

Isolation and diversion of the creek will occur in two stages. The first stage will include a temporary culvert or pump around of the creek to isolate the western creek bend, necessary to facilitate the second stage of creek diversion. The second stage of the creek diversion will involve an installation of a temporary diversion pipe B, a buried, 1200 mm corrugated steel pipe, that will divert the flow of the creek from upstream of the arch culvert to downstream of the

Project Description
April 2017

arch culvert and outside of the creek realignment footprint. As the creek is isolated during the two stages, fish salvage and dewatering will occur to prepare for permanent construction and alteration of the creek alignment. Staged drawings outlining the staged isolation and diversion of the creek are in Appendix A Figures (Aurum Road Interim ESC L001-001 to L001-006).

Berms will be placed at the upstream limit and downstream limit of temporary diversion pipe B. Berms will be 3 m tall, field fit to match surrounding grade and are necessary for hydraulic flow controls of the temporary diversion pipe B on the upstream side of the ravine and to protect the existing creek from construction works on the downstream side of the ravine (see Appendix A Figures, Aurum Road Interim ESC L001-002). Based on UMA/ (UMA Engineering 2008) assessment existing capacity of this culvert is 1.5 m³/s. The maximum flow at the crossing would be in the order of 1.5 m³/s, until 17th street is over topped. The 1200 mm diameter temporary diversion pipe B, under a head of approximately 4 m (due to upstream containment berm) can handle a flow of approximately 3.0 m³/s.

Four sediment forebays and upslope swales are proposed on both sides of the ravine slopes at the upstream and downstream creek diversion points to collect water from the slopes and allow sediment to settle out prior to discharging to the watershed and/or creek. These forebays and swales will also control surface flow during rain events from entering the area between the berms during construction and also for collecting any groundwater encountered during excavation into the slopes or bottom of the ravine.

2.2.1.4 Arch Culvert Installation

The installation of the arch culvert will include a series of slope stabilization measures, excavation, footing preparation and installation, and the placement of the arch culvert.

Shear keys are required to provide a stable foundation for the Mechanically Stabilized Earth (MSE) walls (see Appendix E Geotechnical Report). Four shear keys will be installed, one under each MSE wall that extends into the slope of the ravine. These shear keys will require excavation into the slope and subsurface until bedrock or stable material is reached in order to provide a solid foundation for the walls.

The bottom of the ravine will be excavated and a base will be prepared for the foundation of the arch culvert, wildlife passage and creek realignment. Base materials and dimensions are on Figure L001-L002 Creek Alignment Sections (see Appendix A Figures). Several H-Piles will be placed and capped by concrete to form the foundation of the arch culvert.

Once the foundation is readied, one or two cranes will be used to lift sections of the prefabricated Arch culvert into place.

2.2.1.5 Backfill and Grading

Slopes will be modified to create a road base over the culvert, create the MSE walls, re-stabilize the surrounding slopes to safe conditions and to match or blend into surrounding grades. Erosion



Project Description
April 2017

and sediment control (ESC) measures will be installed in a staged manner as construction progresses (see Appendix F, The Environmental Construction and Methodology Report).

MSE walls will be built up as the slope is graded around the arch culvert. The culvert alignment was designed to reduce the total linear length of MSE wall necessary to lessen the imposing nature of these features. The MSE walls will be sloped downwards from the top of the road edge towards the side slopes and will have terraced material and side slopes placed along them on each side of the culvert to further support the steep ravine crossing as well as provide a secondary benefit of using terraced landscaping to minimize the visual effect of the wall. The MSE walls will have concrete fascia for aesthetics. Drainage swales will be installed around the MSE walls to direct the flow of surface water on the side slopes of the arch culvert from overtopping the MSE walls. These swales will tie into the creek realignment via box culverts installed on the eastern sides, upstream and downstream under the wildlife passage bench. The swales on the western slope will discharge directly to the creek via riprap (see Creek Realignment and Concept Plan in Appendix A Figures).

2.2.1.6 Creek Realignment and Wildlife Passage

Backfill, grading, creek realignment and wildlife passage will likely occur simultaneously. The creek realignment will consist of excavation of the new channel, incorporation of four deep pools, riffles, root wads, and wildlife corridor benches. The creek channel will be excavated and armoured after the installation of the arch culvert. Detailed cross sections of the creek design is included in Appendix A Figures. After the creek is completed, the wildlife passage will be finished by placement of topsoil, brush piles and animal cover areas (mounds and pipe holes into the subsurface with branches obscuring entrances).

The temporary diversion pipe B will be removed or abandoned in place once the new creek bed is finished. This will be completed during the fall, under low flow conditions.

2.2.1.7 Construction of Aurum Road

After installation of the MSE walls and backfill is completed over the arch culvert (PDA1), the final road grade and fine grading will be completed in readiness for pavement. Installation of utilities will be coordinated and installed over the arch culvert, under the road surface.

Construction of Aurum Road will also include installation of the flared pipe that will tie into the SWMF for the industrial development in the area, prior to construction of the road. Once the pipe and flared end are constructed, the paving of Aurum Road overtop of PDA2 will be completed.

2.2.1.8 Reclamation and Revegetation

Final reclamation and revegetation will be completed as per the final landscape concept and design. Landscaping and plantings were chosen to enhance the ravine, wildlife passage and provide cover for the MSE walls. Topsoil will be brought in to allow a variety of plants to be

Project Description
April 2017

placed in the PDA1 that will be dual purpose. For example, willows will be installed along the creek edge to help stabilize the banks, provide cover for the creek and to utilize surface water. Taller trees will be planted on the terraces along the MSE walls, which will add to the aesthetics and add to the stabilization of the slope.

A permanent access road to the wildlife passage on the upstream side of the arch culvert will be left in place for maintenance activities within and around the passage. The access road will be navigable by ATV or light-weight trucks, but will be built to blend in with the natural vegetation.

A wildlife fence and access gate will be installed above the MSE wall to separate Aurum Road and the wildlife passage. Final design and placement of the fence will be determined at detailed design drawing approval.

2.2.2 Operation

Operation activities include the following:

- Daily use of Aurum Road
- Final Acceptance Certificate Requirements
- Wildlife Passage Maintenance Activities

2.2.2.1 Daily Use of Aurum Road

Once open to traffic, Aurum Road will operate as a major access to the industrial development east of the Henday to Highway 21. The road will initially be built as a two lane, one lane in each direction with a dedicated turning lane onto 17 Street.

2.2.2.2 Pre- Final Acceptance Certificate Maintenance Period

After the road is open to traffic and landscaping for the PDA1 is completed and the City of Edmonton awards the Construction Completion Certificate for the Project, a maintenance period will take place prior to issuance of the final acceptance certificate (FAC). During this maintenance period the site will see higher than typical maintenance activities and human presence as contractors perform activities such as weed control, replacement of any failed plantings, erosion repair, addressment of deficiencies, etc. This maintenance period is expected to last 2- to 3-years, but will be dependent on the contractor's ability to meet the requirements of FAC in a timely manner.

2.2.2.3 Wildlife Passage Maintenance Activities

The wildlife passage will require periodic maintenance post-FAC based on the natural materials used during construction. Replacement of the brush piles along the edge of the arch culvert and the woody debris used for animal cover, will need to be done as decay occurs, throughout

Project Description
April 2017

the life of the wildlife passage. Maintenance and clean up may also need to be done during any large storm events, depending on the water flow through the ravine.

2.3 PROJECT SCHEDULE

Construction of the Project will commence once all required permits, approvals, or other forms of specific authorizations are obtained. Construction is scheduled to begin as early as March 2017 and to continue for a period of 8 – 18 months. Following construction, operation will begin as Aurum Road is anticipated to be open for traffic in late November, 2017. Final reclamation and landscaping may proceed beyond this date. Operation of the Project will be continuous and permanent.

2.4 REGULATORY ENGAGEMENT AND CONSULTATION

Table 1 outline the types of engagement/consultation that were completed for the Project between the Proponent, Stantec and the regulator, and how this engagement has influenced the design.

Table 1 Regulatory Engagement and Consultation Record

Date	Type of Consultation	Attendees
June 9, 2016	Meeting to discuss the scope of the Environmental Impact Assessment report	From the City of Edmonton: Brittany Davey, Achyut Adhikari, Alan Mangory, Mark Pivovar, Corey Toews From Stantec: Obaid Rizvi, Kurtis Fouquette Proponent representative: Chris Reiter
December 6, 2016	Meeting to review the landscape architecture plan for the arch culvert crossing the Clover Bar Ravine and provide an update on what will be included into the Environmental Impact Assessment.	From the City of Edmonton: Brittany Davey, Catherine Shier, Laura Gyns From Stantec: Obaid Rizvi, David Price, Katie Hurst, Kurtis Fouquette, William Harper, Elaine Little

2.5 PUBLIC ENGAGEMENT AND CONSULTATION

The Proponent and Stantec have engaged in multiple discussions with Alberta Infrastructure, as the adjacent and downstream landowner to the north and west border of the Project. Discussions with the tenants of the Industrial Park, which make up the majority of the landowners in the area, have also occurred. A public notice, as part of the Water Act approval, will be completed in early 2017 as part of the Project public engagement.



2.6 PROJECT ALTERNATIVES

A Site Location Study (SLS) was completed under separate cover for Aurum Road, which provides a comparison of access options for the Industrial Park, including a status quo option (no change), an option to upgrade existing roadways, and the current proposed option of constructing Aurum Road. The analysis of the SLS identified the current proposed option as having the potential to alleviate traffic issues in the larger region, not just providing access to the Industrial Park, but also alleviating pressure on Highway 16 by providing a bypass between Anthony Henday Drive and Highway 21.

During the Preliminary Design process initiated by the City of Edmonton (City of Edmonton 2013), four crossing options were considered, and compiled in a report, including:

- A single culvert for hydraulic flow
- A larger, single culvert to accommodate wildlife,
- A two/three culvert option, and
- A bridge

The preliminary design report weighed engineering, financial and environmental factors. According to this report, a meeting was held on July 17th, 2014, between the City of Edmonton internal departments (Roads Design and Construction, Transportation Planning, Office of Biodiversity) and Spencer Environmental, at which time the mutually agreed upon best option to proceed with was determined to be the single culvert with wildlife passage. This was chosen based on:

- Option would not alter or change the existing movement patterns of animals using the ravine, and the animals would be able to transverse along the bottom of the ravine as opposed to the long, steep slopes
- Utilities would be more easily accommodated than in the bridge option
- All wildlife would be channelized into one area and be kept away from the road surface
- Traffic noise would be unlikely to impact wildlife using the crossing structure
- Pedestrians using the shared-use path on Aurum Road will have a difficult time accessing the wildlife crossing structure

In 2016, the current Project Proponent was engaged by the City of Edmonton to complete detailed engineering and construction based on preliminary design. Stantec was subsequently retained to complete the design and associated approvals work for an arch culvert, with a wildlife passage of a 2.0 openness index (see Appendix G, Section 4.1.1 for the definition of the openness index) as per the preliminary design provided by the City of Edmonton. To confirm the best options for the crossing, Stantec completed a second Preliminary Engineering Design Report, initiated after discussion regarding the City of Edmonton's Preliminary Design process was determined to not have progressed through full technical evaluation. From the Stantec Preliminary Engineering Design Report (January 2017), careful analysis of the 3 options that included a wildlife passage for the crossing were completed and compared (see Table 4, Preliminary Engineering Design Report). The recommended option was determined to be the

Project Description
April 2017

concrete arch culvert crossing, which was taken to detailed design. Further to this, for the bridge option, the length of the bridge would have extended to the intersection with 17 Street, which would not function from a traffic movement perspective and is not recommended, as well as the other items noted in Section 13.0 of the Stantec Preliminary Engineering Design Report (January 2017). The Stantec Preliminary Engineering Design Report and this EIA does not include a detailed analysis for all environmental impacts of the alternative preliminary options based on the required scope of the Project.

2.6.1 Options Considered During the Detailed Design Process

Two design options were considered at the commencement of detailed design. Option 1 was the preliminary design provided to Stantec, and Option 2 was a variant on this design.

2.6.1.1 Option 1: Preliminary Design Package

The preliminary design provided to Stantec consisted of a 16 m wide x 7 m tall x 55 m long arch culvert crossing. This design involves a creek realignment of over 200 m in length and does not account for the existing topography within the ravine, placing the base of the arch culvert in a location where the existing grade is 6 m in elevation higher than the current creek banks. This design requires MSE retaining wall to span the entire width of the ravine, and results in significant cut and fill to construct that may not be geotechnically feasible, and may not be possible to contain within the existing top-of-bank.

2.6.1.2 Option 2: Realigned Arch Culvert (The Proposed Option)

As the alignment presented in the preliminary design was not ideal, Stantec set out to optimize the design to better fit the alignment of the creek and ravine. The goal was to change the position of the arch culvert to better match the alignment of the ravine. This made the culvert longer, which necessitated a larger culvert to maintain the 2.0 openness index. The dimensions of the redesigned culvert are 21.5 m wide x 8 m in height x 67 m in length. Enhancements such as brush piles and buried pipes for small medium wildlife cover have been incorporated to help mitigate the increase in length. This design required less cut and fill than Option 1, a shorter creek realignment (174 m), grading can be contained within the existing top-of-bank of the ravine, and there will be less geotechnical concerns than Option 1.

2.6.2 Rationale for Choosing Option 2

Completion of Aurum Road will provide an easily accessible route into the Industrial Park, and will alleviate traffic congestion on 17 Street NE. The City of Edmonton provided the Proponent and Stantec with preliminary engineering on the ravine crossing as an arch culvert. The preliminary crossing alignment was refined and optimized during detailed design to achieve a final alignment that provides the best option between minimizing the length of the arch culvert and width for achieving the openness index of 2.0. It also allows for the least amount of slope re-contouring, which is important in this ravine based on the geotechnical challenges (i.e., side

AURUM ROAD ENVIRONMENTAL IMPACT ASSESSMENT, EDMONTON, ALBERTA

Project Description
April 2017

slope stability) in the ravine. Although the creek will be realigned and a loss of creek length is necessary for the design, the existing creek is narrow and the design will allow for widening of the creek, creation of stepped boulders, riffles, addition of deep pools and gravel installed. All of these design features are further discussed in Section 2.2.1.

3.0 SCOPE OF THE ASSESSMENT

As the Project falls under Bylaw 7188, an environmental impact assessment is required.

3.1 SELECTION OF VALUED COMPONENTS

Stantec, the Proponent and the City of Edmonton met on June 9, 2016 to discuss the scope of the EIA for the Project. During the meeting, the discussion focused on construction timing and schedules, and the elements of design that the City of Edmonton wanted to see in the submission including the following:

- geotechnical information
- pre and post development flow information for the creek
- minimum of concept landscape design
- 2.0 openness for wildlife passage
- Creek diversion information

The selection of valued components (VC) were not discussed, therefore Stantec has made a selection for the EIA based on Bylaw 7188, previous experience completing EIA's, Project activities and environmental interactions and professional judgement. While not all biophysical components may have been selected as VCs, some aspects of the physical environment may be discussed under other VCs (e.g., noise may fall under sensory disturbance for wildlife). Items that are not considered valued components are scoped out of the effects assessment and are only discussed in the context of baseline conditions.

The selected VCs include:

- Viewscape
- Surface Water
- Fish and Fish Habitat
- Vegetation
- Wildlife
- Historical Resources

3.2 SPATIAL AND TEMPORAL BOUNDARIES

Consideration of environmental effects in this EIA is conceptually bound in space and time, more commonly known as spatial and temporal boundaries of the assessment. The spatial boundaries reflect the geographic area over which the Project's potential environmental effects may occur. The temporal boundaries identify when an environmental effect may occur in relation to specific Project components and/or activities. Spatial and temporal boundaries are developed in consideration of:

- timing/scheduling of Project activities

AURUM ROAD ENVIRONMENTAL IMPACT ASSESSMENT, EDMONTON, ALBERTA

Scope of the Assessment
April 2017

- understanding natural variations of each Valued Component (VC)
- the time required for recovery from an environmental effect

The spatial boundaries for the Project are defined below with respect to Project components and activities:

- The Project Development Area (PDA): The PDA described within this report is defined as the area in which Project activities and components may occur, and as such represents the area within which direct physical disturbance may occur as a result of the Project, both temporary and permanent. The PDA is split into two areas for this Project:
 - PDA1 – 2.8 ha area where the Project intersects the top of bank survey line for the NSRV and all the temporary and permanent disturbance of the Project within the ravine below the top of bank
 - PDA2 – 0.3 ha area where the Project intersects and crosses with areas below the top of bank survey lineBoth PDA1 and PDA2 are consistent for all VCs (Figure 1).
- The Local Assessment Area (LAA): The LAA described within this report was determined in consideration of the fact that the PDAs are within a defined area bound by roadways and ROWs. The LAA adequately represents an area to represent environmental effects from Project activities and components can be predicted or measured with a reasonable degree of accuracy and confidence. The LAA for this EIA is the same for all VCs and covers approximately 65 ha (Figure 1 Local Assessment Area and Project Disturbance Areas).

The temporal boundaries for the Project encompass all Project activities. Construction is anticipated to begin in March 2017 and is expected to take approximately 8 – 18 months, with traffic on Aurum Road beginning in late 2017.

3.3 REGULATORY AND POLICY SETTING

Various federal, provincial, and municipal acts, regulations, bylaws, or policies were considered in the selection of VCs and assessment of environmental effects.

Table 2 lists the pieces of legislation that are applicable to the Project and that provide the regulatory setting for the Project.

Table 2 **Applicable Legislation**

Regulatory Level	Legislation
Federal	<i>Canadian Environmental Protection Act, 1999</i> <i>Fisheries Act</i> <i>Migratory Birds Convention Act, 1994</i> <i>Species At Risk Act</i>



AURUM ROAD ENVIRONMENTAL IMPACT ASSESSMENT, EDMONTON, ALBERTA

Scope of the Assessment
April 2017

Regulatory Level	Legislation
Provincial	<i>Environmental Protection and Enhancement Act</i> <i>Historical Resources Act</i> <i>Occupational Health and Safety Act</i> <i>Water Act</i> <i>Weed Control Act</i> <i>Wildlife Act</i>
Municipal	City of Edmonton Erosion and Sedimentation Control Field Manual City of Edmonton Erosion and Sedimentation Control Guidelines City of Edmonton Zoning Bylaw (Bylaw 12800) Community Standards Bylaw (Bylaw C14600) Corporate Tree Management Policy (Policy C456A) Development Setbacks from River Valley/Ravine Crests (Policy C542) Drainage Bylaw (Bylaw 16200) North Saskatchewan River Valley Area Redevelopment Plan (Bylaw 7188) The Way We Green: The City of Edmonton's Environmental Strategic Plan The Way We Grow: Municipal Development Plan (Bylaw 15100) The Way We Live: Edmonton's People Plan

4.0 BASELINE CONDITIONS

4.1 SOCIOECONOMIC SETTING

4.1.1 Historic and Current Land Use

Historically, land in the LAA was used for agricultural purposes on the tablelands and the ravine existed much as it does today. The area surrounding the LAA has been subject to development through the more recent years as development pushes from the inner city limits to the outer city limits. The LAA is bordered to the north and west by Alberta Infrastructure owned land, consisting of a major pipeline ROW and the transportation utility corridor (TUC). Roadways bound the southern, western and eastern extents of the LAA. An ATCO substation occupies the lower southwestern corner of the LAA and two areas of Environmental Reserve extend from the southern roadway to the north where they meet the Alberta Infrastructure pipeline ROW. The tablelands consist of agricultural lands, still used for crop production, however this land has been zoned and is planned for industrial development.

4.1.2 Adjacent Land

The Project LAA is surrounded by industrial development, highways and utility corridors. To the west of the LAA lies the northeastern Henday within TUC. South of the LAA, the land is occupied by existing industrial development and rail lines. East of the LAA is more industrial development and the continuation of Aurum Road. North of the LAA is the pipeline ROW within land owned by Alberta Infrastructure, the Edmonton Waste and Management Centre and then ultimately, the NSR.

4.2 PHYSICAL ENVIRONMENT

4.2.1 Viewscape

The Project is located within the Clover Bar Ravine and a small portion of another, dry unnamed ravine, both tributaries to the NSR, a provincially significant natural area and a major ecological corridor that traverses the Province of Alberta (ESRD 2015). PDA1 viewscape is dominated by the steep ravine slopes, consisting mainly of aspen trees and a low-flow creek at the base of the ravine. At the top of the ravine and PDA2 the view in most directions consists immediately of ravine or tributaries of the NSR, industrial development, agricultural hayfield, or roadways with interspersed trees and bushes.

4.2.2 Geology, Topography and Soils

A detailed discussion of the geology and topography within PDA1 can be found in Appendix E Geotechnical Report.

Baseline Conditions
April 2017

The NSR and its tributaries in the Edmonton area were formed following the drainage of Glacier Lake Edmonton, about 12,000 years ago (EGS 1993). Over the last 8,000 years, the river has been widening and meandering within the valley it initially formed in (EGS 1993). As erosion continues, the NSR valley and tributaries continue to be affected by undercutting and slumping, particularly at the outside meander bends, while the inside meander bends are prone to deposition of sediment, building up the flood plains and point bar deposits (EGS 1993). Within the City of Edmonton, the Edmonton Waste Management Centre is built on one of the flood plain terraces of the NSR, and received the discharges and flow of the creek, from the ravine, for which the Project will cross.

The Bedrock in this area belongs to the upper Cretaceous, Horseshoe Canyon Formation of the Edmonton Group, which underlies surficial glaciolacustrine and glacial till deposits from Glacial Lake Edmonton (Kathol and MacPherson, 1975). The Horseshoe Canyon Formation is generally comprised of interbedded mudstones (bentonitic shales), sandstone and coal seams with occasional thin bentonite seams.

Topographic contours and LiDAR imaging suggest that an identified knob (B6, Figure 2 Borehole Location Plan at Creek Crossing, Appendix E) on the valley slope located within PDA1 may be a relic slump block. While it is considered that the ravine slopes are presently inactive, the potential for reactivation of slope movement is possible through lateral erosion or grading activities.

Soils within the LAA have been identified as a mixture of Penhold Loam and Unclassified soils (Kathol and MacPherson 1975). The Penhold Loam is an Orthic Black Chernozem which developed on calcareous alluvial lacustrine material and the unclassified soils consist of rough, broken land adjacent to stream courses.

4.2.3 Groundwater and Surface Water

The creek is part of a watershed that is approximately 2,050 ha, overlapping both the City of Edmonton and Strathcona County. Water flows within the watershed generally to the northwest towards the NSR, as does the creek. Much of the watershed has been subjected to depletion through the addition of SWMF and development, and flows have steadily decreased and are expected to decrease further based on ongoing development (UMA Engineering 2008).

The surface water in the LAA follows the same flow as the overall watershed towards the northward, as it is dominated by the ravine and creek system.

Piezometers were installed in many of the geotechnical boreholes drilled during the geotechnical investigation onsite (Appendix E Geotechnical Report). Measured water levels were recorded equivalent to the creek level in boreholes at the bottom of the ravine. Levels at about creek level were also encountered in some boreholes on the slopes where permeable layers such as coal seams appear to be interconnected to the valley floor. However, higher groundwater levels were found in many installations sealed in clay shale deposits towards the crests of the slopes, with levels ranging from 5 m to 15 m above the creek level.

Baseline Conditions
April 2017

Surface water in PDA1 flows from the top of bank to the creek along the steep sloped sides and generally runs from the southwest to the northeast in the same manner the creek flows. Water that reaches the creek would continue as flow, eventually to the NSR. Between the upstream limits and downstream limits for PDA1 a drop of approximately 1 m elevation occurs. Surface water beyond the top of bank for the ravine runs either towards the ravine or into the storm ditches that line 17th Street and 127 Ave. Surface water flows from the storm ditches along the northern side of 127 Ave are currently draining overland to the area below the top of bank south of PDA2 (see Figure 2).

4.2.4 Fish and Fish Habitat

The creek originates approximately 5 km southeast from PDA1 in the vicinity of the intersection of Lakeland Drive and Clover Bar Road (Edmonton, Alberta) and flows in a northwesterly direction for approximately 6.5 km before entering the NSR. Anthropogenically transformed landscapes (i.e., storm water ponds, highways interchanges, highway and road crossings, ditches, and clearings) are present throughout, however a notably high density of human development is present with the upper and lower reaches of Clover Bar Creek.

Within the LAA, the creek is unmapped and enters into a mapped, Class A section of the NSR. As such, it is subject to special conditions. As the creek does not enter the NSR via an outfall structure, "Class A status applies to the 100 m portion of the creek upstream from its confluence with the NSR. Class C status applies to the portion of the creek upstream of the Class A reach" (ESRD 2013). The crossing location is approximately 2.3 km from the confluence, and as such is assigned a Class C status (ESRD 2013).

PDA1 is situated downstream of a beaver impoundment, with channel and wetted width measured at 3.8 m, and the maximum depth was 0.9 m. Substrates are comprised mainly of fines (85%), with some organics (5%) and gravels (10%) (see Appendix D Fish and Fish Habitat Assessment).

Habitat upstream is shallow, type R3 run habitat with a mix of fine and gravel substrates. Maximum depth ranged from 0.28 to 0.35 m deep. Habitat downstream of PDA1 continuously alternated between riffles, shallow runs and shallow pools. Substrates were predominantly coarse, with the majority (50-70%) being large gravel. Maximum depths at the transect locations ranged from 0.16 to 0.26 m. Maximum recorded pool depth was 0.58 m deep.

Overall, fish habitat within the creek was moderate for all fish species but favours small-bodied individuals. Moderate to good spawning and rearing habitat was observed. Overwintering habitat is the most limiting habitat factor as areas of adequate depth (i.e., > 1.0 m) were not observed.

Three fish species have been documented in the creek: (brook stickleback (*Culaea inconstans*), fathead minnow (*Pimephales promelas*), and white sucker (*Catostomus commersonii*). However, an additional 19 fish species have been documented (AEP 2016) within the portion of the NSR

Baseline Conditions
April 2017

that was included in the LAA (Appendix D Fish and Fish Habitat Assessment, Table 5-1). None of the fish species identified in the LAA are provincially or federally listed under legislated protection.

However, five species of conservation concern were identified within the vicinity of the LAA. Under the Alberta Wild Species 2010 report (ESRD 2012a), lake sturgeon, finescale dace and river shiner were listed as “Undetermined”, and spoonhead sculpin and northern redbelly dace as “May be at Risk” and “Sensitive”, respectively. Lake sturgeon is provincially listed as “Threatened” and “Endangered” under the Alberta Wildlife Act and COSEWIC, respectively. All five of these species were found in the NSR, but have not been documented in the creek.

For further details on the baseline fish and fish habitat for the LAA, see Appendix D Fish and Fish Habitat Assessment.

4.2.5 Vegetation

The LAA is situated within the Central Parkland Natural Subregion (Central Parkland), which is located within the Parkland Natural Region (Natural Regions Committee 2006). This Subregion is a large transition zone between the Boreal Forest Natural Region to the north and the Grassland Natural Region to the south. The Central Parkland is dominated by undulating till plains and hummocky uplands. Under natural conditions, native vegetation community remnants are a mosaic of aspen (*Populus tremuloides*) dominated forest stands on moist sites intermixed with prairie vegetation on drier sites. Stands of aspen dominated forest are found throughout the Central Parkland and have understories dominated by saskatoon (*Amelanchier alnifolia*), prickly rose (*Rosa acicularis*), and beaked hazelnut (*Corylus cornuta*). Stands dominated by balsam poplar (*Populus balsamifera*) occur on moist, nutrient rich sites, and often have aspen and white spruce (*Picea glauca*) intermixed within the stand (NRC 2006).

Six native plant communities were observed during site specific rare plant and site characterizations assessments (Stantec 2016a). None of the communities observed are listed as rare or sensitive plant species or communities. Native plant communities that dominate the PDA1 are aspen woodland alliance, aspen poplar woodland alliance, and a short shrub alliance (Stantec 2016a). Native plant communities that dominate the PDA2 are perennial pasture or otherwise disturbed (soils and vegetation disturbance) area. For further details on the baseline vegetation for the LAA, see Appendix B Vegetation Technical Data Report.

4.2.6 Wildlife

The City of Edmonton (2008) lists 225 species that may occur within the LAA. These species include 178 birds, 47 mammals, and seven herptiles. Twenty percent (i.e., 46 species) of the 225 species that may occur in the LAA are listed as SOMC either federally and/or provincially (City of Edmonton 2008).

AURUM ROAD ENVIRONMENTAL IMPACT ASSESSMENT, EDMONTON, ALBERTA

Baseline Conditions
April 2017

Amphibians and reptiles represent less than five percent of species that have the potential to occur in the LAA (City of Edmonton 2008) including wood frog (*Lithobates sylvatica*), boreal chorus frog (*Pseudacris maculata*), and red-sided garter snake (*Thamnophis sirtalis*) (City of Edmonton 2008). Wood frog was detected in the LAA by Stantec (2008), AMEC Foster Wheeler (2015) and Stantec (2016b) identified suitable habitat for the amphibians in the LAA.

Although the total number of bird species varies in the literature, it is estimated that birds represent approximately 80 percent of wildlife species that may occur in the LAA. According to the City of Edmonton (2008), 178 bird species occur within Edmonton. Stantec (2016b) recorded 28 bird species in the LAA, and EPEC (1981) estimated that 150 bird species occur within the NSR valley and ravine system. However, a large number of these species are neo-tropical migrants and are only present during the breeding season.

Mammals represent approximately 20 percent of species that may occur in the LAA (City of Edmonton 2008). Small mammals common in the Greater Edmonton area include beaver (*Castor canadensis*), muskrat (*Ondatra zibethica*), snowshoe hare (*Lepus americanus*), Franklin's ground squirrel (*Citellus franklinii*), northern flying squirrel (*Glaucomys sabrinus*), porcupine (*Erethizon dorsatum*), red squirrel (*Tamiasciurus hudsonicus*), skunk (*Mephitis mephitis*), white-tailed jack rabbit (*Lepus townsendii*), deer mice (*Peromyscus maniculatus*), red backed vole (*Microtus microtus*), shrews (Family *Soricidae*), western jumping mice (*Zapus princeps*), house mouse (*Mus musculus*), and big brown bat (*Eptesicus fuscus*) (EPEC 1981; City of Edmonton 2008).

Some larger mammals such as white-tailed deer (*Odocoileus virginianus*), mule deer (*Odocoileus hemionus*), moose (*Alces alces*), coyote (*Canis latrans*), and red fox (*Vulpes vulpes*) are also commonly observed in the NSR valley and ravine system. Other large mammals including black bear (*Ursus americanus*), Canada lynx (*Lynx canadensis*), and cougar (*Puma concolor*) may also be observed occasionally within the LAA because the NSR valley and ravine system is part of a large ecological corridor that provides connectivity across the province that may be used by these large mammals (EPEC 1981).

The LAA is located in the provincially designated sensitive Raptor Range for bald eagle and Sharp-tailed Grouse Survey Area (AEP 2016). While the LAA is within the identified range for sharp-tailed grouse, it is unlikely that this species would occur here because the open prairie habitat it is associated with (Connelly et al. 1998) is not available within the LAA. It is possible that bald eagles utilize the LAA as they are known for nesting near water bodies due to their reliance on fish as a food source (Buehler 2000).

Based on amphibian surveys and breeding bird surveys completed within the LAA (Stantec 2016b), Boreal chorus frog and 28 bird species were observed or heard. Six white-tailed deer were also observed during the amphibian surveys. Four of the bird species detected are Species of Management Concern (listed as *sensitive* in Alberta): barn swallow, least flycatcher, osprey and western-wood pewee (see Appendix C Wildlife Technical Data Report).

Baseline Conditions
April 2017

A Key Wildlife Biodiversity Zone (KWBZ) associated with the North Saskatchewan River and its tributaries extends into the northeast corner of the LAA. KWBZs are sensitive areas identified by AEP as having high biodiversity potential and/or being key ungulate winter habitat. Major river valleys, where KWBZ are typically located, provide the necessary topographic variability and productivity to support high biodiversity and abundant winter browse for ungulates (ESRD 2015).

For further details on the baseline wildlife for the LAA, see Appendix C Wildlife Technical Data Report.

4.2.7 Historical Resources

The Project footprint is in lands included within the historical resource listing for Alberta (ACT September 2015) with HRVs of 4a and 5a. The HRV of 4a is due to the presence of precontact campsite, considered to be of high heritage value and with recommendations for avoidance of impact or completion of 40 m² of archaeological excavation (Minni 1989). The HRV of 5a indicates areas of high archaeological resource sensitivity, acting as a buffer around a site.

Minni (1989) conducted the most comprehensive impact assessment for this area, recording 17 precontact sites and two areas of historic structures within the extensive Waste Management Centre footprint, which extended within and beyond the LAA.

There are eight archaeological sites and one historical structure site recorded in the LAA. This is not surprising given the general location within 1 km to 2 km of the NSR, with the Project footprint along the valley edge. The sites tend to be clustered along the ravines/watercourses draining into the NSR, as well as along the margins of seasonal sloughs. The site patterning suggests that any areas of remaining native vegetation and limited slope would be of high archaeological potential. Remaining areas that have been cleared and cultivated are of lower potential.

4.2.7.1 Archaeological Overview

Three precontact period archaeological sites were evaluated within the PDA1, including two artifact scatters (FjPh-106 and FjPh-148), and one campsite (FjPh-104). Sites FjPh-104 and FjPh-148 are considered to be of high heritage value; avoidance of impact or further work are recommended. Recommendations for further work consist of mitigative excavation at site FjPh-104 and monitoring at site FjPh-148. The remaining precontact sites are considered to be of limited remaining heritage value and no further work is recommended. The historic Gillies/Bailey farmyard, within the LAA, was also assessed and considered to be of limited remaining heritage value. No further work is recommended. These recommendations are presented within the HRIA final permit report, which will be submitted to ACT for consideration and issuance of any requirements under the *HRA*.

4.2.7.2 Palaeontological Overview

Bedrock in the region consists of the Cretaceous Horseshoe Canyon Formation. This is a fossiliferous unit that yields invertebrates, plants, amphibians, reptiles, dinosaurs and early mammals. Preglacial gravel of the Empress Formation overlies the bedrock at the deep ravine crossed by the Project. The gravel has high potential for Pleistocene mammals. Project surveys found abundant bison bone within the ravine. Given the abundance of the bone and the co-occurrence of lithic artifacts and fire-broken rock, it is likely that the bone is of archaeological rather than palaeontological origin. Two shellbeds of Holocene age were also noted along the creek within the LAA. As the Inter Pipeline 2 site lies directly downstream of the PDA1, alteration of the creek flow could affect the site. No fossils were found in situ at the exposures along the ravine.

A Historical Resources Impact Assessment (HRIA) was requested by ACT for areas within the LAA.

5.0 ASSESSMENT OF POTENTIAL ENVIRONMENTAL EFFECTS ON VALUED COMPONENTS

5.1 VIEWSCAPE

5.1.1 Potential Effects, Pathways, and Measurable Parameters

The assessment of Project-related effects on the viewscape focuses on one potential effect.

Table 3 presents the potential effects, effect pathway and measurable parameters for the assessment of effects on the viewscape.

Table 3 Potential Effects, Effects Pathways, and Measurable Parameters for Viewscape

Potential Effect	Effect Pathway	Measurable Parameter(s) and Units of Measurement
Change in the viewscape	Removal of natural vegetation and installation of the Arch Culvert may reduce the quality of the view of the ravine	Qualitative changes to viewsapes

5.1.2 Criteria for Characterizing Residual Effects

Characterizations of residual effects are defined in Table 4 Residual Effect Characterization Definitions for Viewscape.

Table 4 Residual Effect Characterization Definitions for Viewscape

Parameter	Description	Definition
Direction	Whether the residual effect is assessed to have a positive, adverse, or neutral effect on the measurable parameters or the VC	<p>Positive – a residual effect that moves measurable parameters in a direction beneficial to the VCs relative to baseline conditions</p> <p>Adverse – a residual effect that moves measurable parameters in a direction detrimental to the VCs relative to baseline conditions</p> <p>Neutral – no net change in measurable parameters for the VCs relative to baseline</p>

AURUM ROAD ENVIRONMENTAL IMPACT ASSESSMENT, EDMONTON, ALBERTA

Assessment of Potential Environmental Effects on Valued Components
April 2017

Parameter	Description	Definition
Magnitude	The amount of change in measurable parameters of the VC relative to baseline conditions	Negligible—no change Low—a measurable change that affects a small number of land users. Moderate—measurable change but less than high because the change affects less than the majority of land users. High—measurable change that affects the majority of land users.
Spatial Extent	The spatial area in which a residual effect occurs	PDA – residual effects are restricted to the PDA LAA – residual effects extend into the LAA
Frequency	How often the residual effect occurs	Single Event – occurs only once Multiple Irregular Events – occurs at no set schedule Multiple Regular Events – occurs at regular intervals Continuous – occurs continuously
Duration	The period of time required until the measurable parameter of the VC returns to its baseline condition, or the residual effect can no longer be measured or otherwise perceived	Short-term– residual effect is measurable for during construction only Medium-term – residual effect is measurable for the FAC maintenance period of 3 years Long-term – residual effect is measurable while revegetation is established (10 years) Permanent – residual effect is measurable in perpetuity

5.1.3 Project Interactions with Viewscape

Table 5 identifies Project activities that have the potential for effects on the Viewscape. These interactions (indicated by check marks) are discussed in detail in the context of effects mechanisms, standard and Project-specific mitigation, and residual effects in Sections 5.1.4 and 5.1.5.

Table 5 Project Environment Interactions with Viewscape

Physical Activities	Potential Environmental Effects
	Change in viewscape
Construction	
Vegetation Clearing	✓
Creation of construction access	-
Creek isolation and pump around	-
Arch Culvert Installation	✓
Backfill and Grading	-



AURUM ROAD ENVIRONMENTAL IMPACT ASSESSMENT, EDMONTON, ALBERTA

Assessment of Potential Environmental Effects on Valued Components

April 2017

Physical Activities	Potential Environmental Effects
	Change in viewscape
Creek Realignment and Wildlife Passage	-
Construction of Aurum Road	✓
Reclamation and revegetation	✓
Operation	
Daily use of Aurum Road	-
Final Acceptance Certificate Requirements	-
Wildlife Passage Maintenance Activities	-
<u>NOTES</u>	
✓ = Potential interaction	
- = No interaction	

5.1.4 Assessment Techniques

A residual effects assessment of the viewscape for the ravine was conducted qualitatively by a comparison of the current natural viewscape and the expected viewscape once the Project is completed (see Appendix A, Figure of Aurum Road Creek Realignment Concept Plan). The potential for interactions between Project phases and activities with the viewscape was assessed.

5.1.5 Assessment of Change in Viewscape

5.1.5.1 Project Pathways

The Project may affect users of the ravine as the landscape changes from the natural ravines and creek system to the removal of vegetation and the placement of the arch culvert and Aurum Road overtop. The viewscape will be interrupted by the structures and will no longer be a continuous natural system. Potential users of the ravine may find the change in the viewscape to hinder their future use of the LAA for recreational activities.

5.1.5.2 Mitigation Measures

Mitigation measures for potential changes in the viewscape include the following:

- Minimize the disturbance as much as possible to the final footprint of the PDA1 and PDA2
- Complete the Project construction within the proposed timeframe and reclaim and revegetate the ravine as soon as possible
- Use plantings and vegetation that will mask the visual effect of the arch culvert structure and the regraded slopes to the extent possible

5.1.5.3 Residual Effects

The Project will result in a permanent loss of 3.1 ha of natural ravine for PDA1 and PDA2 combined, a total of 5% of the LAA. The ravine is surrounded by industrial development, as it bisects land that is zoned as IB. Reclamation and revegetation will occur in areas of PDA1 (see Appendix A Figures, Creek Realignment Concept Plans). While the viewscape will be altered permanently, the relatively small scale of this loss, and with mitigations will reduce the magnitude of this change to low and limit it to the PDA1 and PDA2. The use of the PDA1 for human activities may be reduced, however access is already limited based on land ownership and restricted access within the region surrounding the LAA (i.e., pipeline ROW, TUC).

5.1.6 Summary of Residual Effects on Viewscape

A summary of Project residual environmental effects on viewscape is presented in Table 6.

Table 6 Residual Effect Characterizations for Viewscape

Residual Effect	Residual Effect Characterization				
	Direction	Magnitude	Spatial Extent	Frequency	Duration
Change in viewscape	A	L	PDA	C	P
<p><u>KEY</u> Direction: P – Positive; A – Adverse; N – Neutral Magnitude: N – Negligible; L – Low; M – Moderate; H – High Spatial Extent: PDA – Project Development Area; LAA – Local Assessment Area Frequency: S – Single event; IR – Multiple Irregular event; R – Multiple Regular event; C – Continuous Duration: ST – Short-term; MT – Medium-term; LT – Long-term; P – Permanent</p>					

5.2 SURFACE WATER

5.2.1 Potential Effects, Pathways, and Measurable Parameters

The assessment of Project-related effects on surface water focuses on the change in surface water quality and the change in the hydrological flow of the creek and surface water in PDA2.



Table 7 presents the potential effects, effect pathways and measurable parameters for the assessment of effects on surface water.

Table 7 Potential Effects, Effects Pathways, and Measurable Parameters for Surface Water

Potential Effect	Effect Pathway	Measurable Parameter(s) and Units of Measurement
Change in sediment load and water quality	Increased sediments and contaminants to the creek	Potential for the introduction of suspended sediment to the creek during construction
Change in hydraulics of Clover Bar Creek and the western dry ravine	Redesign of the creek dimensions resulting in potential changes to the flow Installation of the flared end pipe below the top of bank will result in changes to the flow	Velocity of creek flows Potential for increased erosion Overland flows in PDA2

5.2.2 Criteria for Characterizing Residual Effects

Characterizations of residual effects are defined in Table 8 Residual Effect Characterization Definitions for Surface Water.

Table 8 Residual Effect Characterization Definitions for Surface Water

Parameter	Description	Definition
Direction	Whether the residual effect is assessed to have a positive, adverse, or neutral effect on the measurable parameters or the VC	Positive – a residual effect that moves measurable parameters in a direction beneficial to the VCs relative to baseline conditions Adverse – a residual effect that moves measurable parameters in a direction detrimental to the VCs relative to baseline conditions Neutral – no net change in measurable parameters for the VCs relative to baseline
Magnitude	The amount of change in measurable parameters of the VC relative to baseline conditions	Negligible/Low – no increase in the seasonal variability for water quality or flow velocities of the creek, but within accepted guidelines Moderate – increase in the seasonal variability for water quality or flow velocities of the creek, but within accepted guidelines High – increase in the seasonal variability for water quality or flow velocities of the creek and exceedances beyond accepted guidelines
Spatial Extent	The spatial area in which a residual effect occurs	PDA – residual effects are restricted to the PDA LAA – residual effects extend into the LAA

AURUM ROAD ENVIRONMENTAL IMPACT ASSESSMENT, EDMONTON, ALBERTA

Assessment of Potential Environmental Effects on Valued Components

April 2017

Parameter	Description	Definition
Frequency	How often the residual effect occurs	Single Event – occurs only once Multiple Irregular Events – occurs at no set schedule Multiple Regular Events – occurs at regular intervals Continuous – occurs continuously
Duration	The period of time required until the measurable parameter of the VC returns to its baseline condition, or the residual effect can no longer be measured or otherwise perceived	Short-term– residual effect is measurable for a single event (e.g., rain event beyond the 1:2 year level) Medium-term – residual effect is measurable for weeks beyond a single event (e.g., rain event beyond the 1:2 year level) Long-term – residual effect is measurable for months to years beyond any rain event. Permanent – residual effect is measurable in perpetuity

5.2.3 Project Interactions with Surface Water

Table 9 identifies Project activities that have the potential for effects on the surface water. These interactions (indicated by check marks) are discussed in detail in the context of effects pathways, standard and Project-specific mitigation, and residual effects in Sections 5.2.4, 5.2.5 and 5.2.6.

Table 9 Project Environment Interactions with Surface Water

Physical Activities	Potential Environmental Effects	
	Change in sediment load and water quality	Change in hydraulics of Clover Bar Creek and the western dry ravine
Construction		
Vegetation Clearing	✓	-
Creation of construction access	✓	-
Creek isolation and pump around	✓	✓
Arch Culvert Installation	-	-
Backfill and Grading	-	-
Creek Realignment and Wildlife Passage	-	✓
Construction of Aurum Road	-	-
Reclamation and revegetation	✓	-
Operation		
Daily use of Aurum Road	-	-
Final Acceptance Certificate Requirements	✓	-
Wildlife Passage Maintenance Activities	✓	-
NOTES		
✓ = Potential interaction		
- = No interaction		



5.2.4 Assessment Techniques

A residual effects assessment of the surface water of the creek was conducted based on the current water quality of the creek, seasonal variabilities and sedimentation of the creek and modelling of flow velocities for the natural creek and the realigned channel design. The potential for interactions between Project phases and activities with surface water was assessed.

5.2.5 Assessment of Change in Sediment Load and Water Quality

5.2.5.1 Project Pathways

The sediment load and quality of the water in the creek may be affected during construction activities surrounding the creek including vegetation clearing, creation of construction access, creek isolation and pump around and reclamation and revegetation in PDA1. Sediment has the potential to enter the creek during any Project activities involving movement of soils, as enhanced by the steep slopes of the ravine. During the reclamation and revegetation phase of the Project, the creek isolation will be removed and the movement of soil and sediment will again have the potential to enter the creek. During operation phase of the Project, should any maintenance to instream or side stream areas be required, soil and sediment will also have the potential to enter the creek.

The water quality of the creek has the potential to be affected by contamination of fuel, hydraulic fluid or other equipment leaks during instream or near stream work. Hydraulic leaks or fuel line leaks or breaks have the potential to enter the water or the sediment and then the water, which could affect the water quality of the creek.

5.2.5.2 Mitigation Measures

The following mitigation measures have been developed for the Project and are expected to reduce potential effects on water quality.

- effective implementation of the Erosion and Sediment Control (ESC) Plan. ESC measures will be implemented specific to the Project activities that are being constructed. Detailed ESC measures are outlined in Appendix F.
- Project activities that are near or within the creek including creek isolation and pump around will be done during periods of low flow.
- Activities with the potential for sediment releases will be suspended during storm events and monitoring for sediment releases will be directed by a QAES
- Sediment forebays are proposed during construction with swales leading to them to direct and control the flow of surface water over the side slopes of the ravine during construction phases. This will allow for the collection of sediment and water in controlled areas, reducing surface flow directly into areas of active construction. These may also be utilized for dewatering activities from areas where deep excavation is required into the subsurface.
- Contaminants from equipment used during construction will be mitigated through implementation of setbacks or secondary containment measures for equipment refueling, cleaning and maintenance activities. Spill kits will be available onsite during construction.

Equipment will be inspected on a regular basis for leaks and should leaks be found, not be used onsite until repairs have been completed.

5.2.5.3 Residual Effects

Sediment within the creek vary seasonally based on the natural environment it exists within. Current conditions exist whereby surface flows over the steep sided ravine slopes can contribute to natural sedimentation of the creek. However, based on interactions between the Project activities and the creek, potential effects to the sediment load and water quality are not expected to occur. Therefore, no residual effects are anticipated to the sediment load or water quality of the creek.

With the application of mitigation measures, the residual effects of Project construction and operation on the changes to water quality are neutral in direction, low in magnitude, would extend into the LAA should a release occur and would be considered a single event and short term duration.

5.2.6 Assessment of Change in Hydraulics of Clover Bar Creek

5.2.6.1 Project Pathways

The hydraulics of the creek have the potential to be affected by the isolation of the creek, through the installation of the temporary diversion pipe B and based on the design of the creek realignment.

Table 10 outlines the modelled flows for the creek after realignment as compared to the natural creek channel function.

Table 10 Natural Channel and Proposed Realigned Channel Hydraulics

Channel Hydraulics ^C								
Flow	Annual Exceedance Probability (%)	Natural Channel Hydraulics ^A			Proposed Realigned Channel Hydraulics ^B			
		Flow (m ³ /s)	Depth (m)	Velocity (m/s)	Depth of Flow (m)	Mean Velocity at Inlet (m/s)	Velocity Difference (%)	Freeboard and Comments (m)
Q _{design} (1:100 Year)	1	11.9	1.01	2.15	0.94	2.55	19	Wildlife Passage through proposed 21.5 m span x 8 m rise open bottom arch structure will be above design flood elevation
Q _{check} (1:200 Year)	0.5	14.9	1.13	2.32	1.05	2.45	6	Flow Elevation is 0.05 above top of proposed channel bank. Average velocity for 1:200 year flood is lower than that of 1:100 year flood due to flow is out of design channel.

AURUM ROAD ENVIRONMENTAL IMPACT ASSESSMENT, EDMONTON, ALBERTA

Assessment of Potential Environmental Effects on Valued Components

April 2017

Channel Hydraulics ^C								
Flow	Annual Exceedance Probability (%)	Natural Channel Hydraulics ^A			Proposed Realigned Channel Hydraulics ^B			
		Flow (m ³ /s)	Depth (m)	Velocity (m/s)	Depth of Flow (m)	Mean Velocity at Inlet (m/s)	Velocity Difference (%)	Freeboard and Comments (m)
Q (1:50 Year)	2	10.0	0.91	2.05	0.85	2.43	19	
Q (1:2 Year) Fish Passage Flow	50	1.2	0.30	0.98	0.24	1.18	20	

Notes:
^A With roughness coefficient n=0.045 with surveyed average channel slope 0.014 m/m
^B With roughness coefficient n=0.045 (Installing Rock riprap and Fish habitat enhancement measures in proposed channel) with average channel slope 0.021 m/m
^C with 4 m streambed with 1H:1V side slopes and with 1m average depth of channel

The creek will be temporarily diverted through the installation of a temporary diversion pipe B, a buried, 1200 mm corrugated steel pipe, from the upstream limit of the PDA1 to the downstream limit of PDA1. The flow of the creek has the potential to decrease during construction of the temporary diversions. The diversion pipe intake will be within the 3 m high berm, which will temporarily cause back flooding (by design) of the creek during periods of high flow (e.g., storm events), although this back flooding will also be limited based on the upstream culvert at 17th Street and the beaver dam within the stormwater pond that exists on the east side of 17th Street outside of the LAA. The potential decrease in flow may affect the downstream flow of the creek, causing periods of no flow or limited flow or conversely, when the diversion pipe fills, increase the rate of the flow through the temporary diversion pipe B, causing higher potential for scour and erosion at the outlet of the pipe into the natural channel. Natural sedimentation rates are also affected by the change in hydraulics, whereby a decrease in flow rates can create sedimentation to accumulate or an increase in rates removes the natural sedimentation and nutrients necessary for aquatic life.

The channel realignment and design also has the potential to affect the hydraulics of the creek as the channel will be wider and shorter in length once it has been constructed, which can increase the velocity of the water flowing through the channel.

The installation of the Project and flared end pipe (part of the SWMF, see Section 2.1.4) in PDA2 has the potential to alter the flow of surface water in the surrounding LAA. Surface water (including runoff from 127 Ave) collects south of PDA2 where the top of bank starts for the western dry ravine. This flow of water to the northwest into the treed portion of the ravine will be altered by the redirection of the surface water into the SWMF planned for the Industrial Park. Based on the capacity limitations of a pipe based stormwater system, water may also pool south of PDA2 between Aurum Road and 127 Ave during large events (i.e., greater than 1:5 year

flows), until it ultimately flows into the flared end pipe and drains to the SWMF (see Appendix A Figure, ER Site Storm Drainage System).

Hydraulic changes also have the potential for effects to fish and fish habitat, which are discussed under Section 5.3.

5.2.6.2 Mitigation Measures

The mitigation measures that have been developed for the Project and are expected to reduce potential effects on hydraulics of the creek are based entirely of the design of the realigned channel.

- The proposed realigned channel has a 4.5 m wide streambed with 1H:1V side slopes with 1.0 m average depth of channel. The channel will have sinusoidal pattern and will be armoured with large rock along the sides and bottom for scour and erosion protection.
- Riffles, 4 deep pools and root wads will be installed in the realigned portion of the creek which will aid in the control of the flow rates of the creek.
- The realigned channel has been designed for the 1:100 year flood levels, however it will also contain the 1:200 year flood levels.

During temporary diversion of the creek, berms will be built up to 3 m in height upstream where the diversion pipe begins and downstream where the diversion pipe discharges back into the natural creek. The berm at the upstream location is necessary to allow for the creek to backfill upstream in order to “charge” the diversion culvert during storm events. This is necessary to ensure the flows through the pipe utilize the full extent of the available pipe to keep the creek from overflowing into the isolation area where the construction of the arch culvert, wildlife passage and creek realignment work will occur. The downstream berm is necessary to control the output flow rate of the temporary diversion pipe B and ensure backflow from the creek does not happen into the isolated construction area. Riprap and riffle boulders will be placed at the inlet and outlet of the pipe to mitigate for erosion and control the velocity of diverted creek flow from and into the natural stream.

5.2.6.3 Residual Effects

The design of the realigned creek was based on maintaining hydraulic flows of the creek and to mimic a natural environment to support the aquatic environment post construction. Hydraulics of the creek were modelled to inform the design and to provide input on flow rate changes based on the creek dimensions and necessary elements needed to achieve a neutral effect on the flow rates. Alberta Transportation's software, HydroCulv and HydroChan, were used to calculate velocities and flood elevations in the proposed channel and model flows through the natural channel of the creek.

Flows for the 1:100-year flood (11.9 m³/s) was used as the design basis for flooding on the Project (UMA Engineering Ltd 2008). This flood has annual exceedance probability of 1% and is selected per standard industry practices and is considered conservative.

AURUM ROAD ENVIRONMENTAL IMPACT ASSESSMENT, EDMONTON, ALBERTA

Assessment of Potential Environmental Effects on Valued Components
April 2017

The 1:200-year flood was also included in on the creek design drawings (see Appendix A, Creek Alignment Landscape Plans L001-001-004). Based on our experience, the 1:200-year flood is 15 to 30% greater than the 1:100-year flood for this type of creek and drainage area characteristics and is contained within the designed channel. Stantec has estimated 14.9 m³/s as the 1:200-year flood which is 25.2% more than the 1:100-year flood (11.9 m³/s).

A roughness design coefficient equivalent to the baseline creek conditions is the basis of the design, to be within acceptable increased variation of the flow rate for the creek despite the shortening and widening of it. This was achieved in the design by the inclusion of riffles, deep pools, gravel base material, root wads and the sinuous path of the creek.

Therefore, based on the design mitigations of the realignment portion of the creek, limited residual effects are expected on the hydraulics of the creek. It is expected that changes to hydraulics of the creek are neutral in direction, negligible in magnitude, limited to the PDA1 and continuous and permanent.

Surface water flow that intersects with PDA2 will have a residual effect in that the western dry ravine south/upstream of the Project crossing may experience standing water where it did not previously. This may result in sediment deposition or water logging of soils in the area immediately upstream of the flared end pipe. The surface water flows that passed through the vegetated ravine and ditches before reaching PDA2, will likely contain any sediment prior to reaching the catchment area of the flared end pipe. Therefore, based on these limitations already existing for the surface water flow prior to the Project occurring, the hydraulics of surface flow at PDA2 is neutral in direction, negligible in magnitude, extend into the LAA, continuous and permanent.

5.2.7 Summary of Residual Effects on Surface Water

A summary of Project residual environmental effects on surface water is presented in Table 11.

Table 11 Residual Effect Characterizations for Surface Water

Residual Effect	Residual Effect Characterization				
	Direction	Magnitude	Spatial Extent	Frequency	Duration
Change in sediment load and water quality	N	L	LAA	S	ST
Change in hydraulics of Clover Bar Creek and the western dry ravine	N	N	LAA	C	P
<p><u>KEY</u> Direction: P – Positive; A – Adverse; N – Neutral Magnitude: N – Negligible; L – Low; M – Moderate; H – High Spatial Extent: PDA – Project Development Area; LAA – Local Assessment Area Frequency: S – Single event; IR – Multiple Irregular event; R – Regular event; C – Continuous Duration: ST – Short-term; MT – Medium-term; LT – Long-term; P – Permanent</p>					

5.3 FISH AND FISH HABITAT

5.3.1 Potential Effects, Pathways, and Measurable Parameters

The assessment of Project-related effects on fish and fish habitat focuses on the change in fish habitat, change in fish movement, migration and passage and the change in fish mortality.

Table 12 presents the potential effects, effect pathways and measurable parameters for the assessment of effects on fish and fish habitat.

Table 12 Potential Effects, Effects Pathways, and Measurable Parameters for Fisheries and Fish Habitat

Potential Effect	Effect Pathway	Measurable Parameter(s) and Units of Measurement
Change in fish habitat	Change in riparian and in-water habitat availability (including critical habitat of SAR)	Areal extent of altered or destroyed habitat (m ²) Habitat productivity Species and life stage diversity
Change in fish movement, migration and fish passage	Change in flow rates or obstructions	Minimum and maximum seasonal flows (m ³ /s) Creation of flow or passage obstruction in-water
Change in fish mortality	Change in direct mortality risk	Fish mortality occurrences Water quality measurements will be compared to the Canadian Council of Ministers of the Environment (CCME) guidelines for the protection of aquatic life (CCME 2002)

5.3.2 Criteria for Characterizing Residual Effects

Characterizations of residual effects are defined in Table 13 Residual Effect Characterization Definitions for Fisheries and Fish Habitat.

Table 13 Residual Effect Characterization Definitions for Fisheries and Fish Habitat

Parameter	Description	Definition
Direction	Whether the residual effect is assessed to have a positive, adverse, or neutral effect on the measurable parameters or the VC	Positive – a residual effect that moves measurable parameters in a direction beneficial to the fish and fish habitat relative to baseline conditions Adverse – a residual effect that moves measurable parameters in a direction detrimental to the fish and fish habitat relative to baseline conditions Neutral – no net change in measurable parameters for the fish and fish habitat relative to baseline

AURUM ROAD ENVIRONMENTAL IMPACT ASSESSMENT, EDMONTON, ALBERTA

Assessment of Potential Environmental Effects on Valued Components

April 2017

Parameter	Description	Definition
Magnitude	The amount of change in measurable parameters of the VC relative to baseline conditions	Negligible – No change or negligible change in fish found within the PDA or fish habitat Low – Measurable change to fish and fish habitat that is within applicable guidelines, legislated requirements, and/or federal and provincial management objectives High – Measurable change to fish and fish habitat that is not within applicable guidelines, legislated requirements, and/or federal and provincial management objectives
Spatial Extent	The spatial area in which a residual effect occurs	PDA – residual effects are restricted to the PDA LAA – residual effects extend into the LAA
Frequency	How often the residual effect occurs	Single Event – occurs only once Multiple Irregular Events – occurs at no set schedule Multiple Regular Events – occurs at regular intervals Continuous – occurs continuously
Duration	The period of time required until the measurable parameter of the VC returns to its baseline condition, or the residual effect can no longer be measured or otherwise perceived	Short-term– residual effect is restricted to construction phase Medium-term – residual effect is measurable during construction and during the FAC maintenance phase Long-term – residual effect is measurable through operation of the project Permanent – residual effect is measurable in perpetuity

5.3.3 Project Interactions with Fisheries and Fish Habitat

Table 14 identifies Project activities that have the potential for effects on fish and fish habitat. These interactions (indicated by check marks) are discussed in detail in the context of effects mechanisms, standard and Project-specific mitigation, and residual effects in Sections 5.3.4, 5.3.5, and 5.3.6.

Table 14 Project Environment Interactions with Fisheries and Fish Habitat

Physical Activities	Potential Environmental Effects		
	Change in fish habitat	Change in fish movement, migration and fish passage	Change in fish mortality
Construction			
Vegetation Clearing	✓	-	✓
Creation of construction access	-	-	-
Creek isolation and pump around	✓	✓	✓
Arch Culvert Installation	-	-	-
Backfill and Grading	-	-	-
Creek Realignment and Wildlife Passage	✓	✓	-



Physical Activities	Potential Environmental Effects		
	Change in fish habitat	Change in fish movement, migration and fish passage	Change in fish mortality
Construction of Aurum Road	-	-	-
Reclamation and revegetation	-	-	-
Operation			
Daily use of Aurum Road	-	-	-
Final Acceptance Certificate Requirements	-	-	-
Wildlife Passage Maintenance Activities	-	-	-
NOTES ✓ = Potential interaction - = No interaction			

5.3.4 Assessment Techniques

An assessment of residual effects to fish and fish habitat was conducted by Stantec (see Appendix D Fish and Fish Habitat Assessment), based on assessments for the presence and quality of fish habitat (fish habitat as defined by the *Fisheries Act*), fish community composition and habitat associations for important life processes at different times of the year and the realignment of the creek. The potential for interactions between Project phases and activities with fish and fish habitat was assessed.

5.3.5 Assessment of Change of Fish Habitat

5.3.5.1 Project Pathways

The proposed realignment of the creek will result in a loss of 690 m² instream habitat, as the creek will be shortened in length from 174 m to 103 m in the PDA1. Vegetation along the areas where the creek is to be realigned will also be removed during construction. The creek areas for instream work will be isolated and the creek will temporarily be diverted via a buried, 1200 mm corrugated steel pipe (see Section 2.2.1.3 for further details on the process of construction). While the creek is diverted, there will be no habitat within the diversion Pipe B, and fish will not be able to spawn within the pipe.

5.3.5.2 Mitigation Measures

Mitigation measures planned for the creek realignment, consist mainly of design elements to provide suitable engineered elements in the realignment. These elements include:

- The realigned creek will be wider and deeper than the current creek
- The substrate will be changed from the mainly fines and organics to a bio-engineered lined bed with 75 mm depth of 40 mm rainbow river rock and 25 mm sand base overtop a 200 mm depth of crushed rock and sand compacted to 98%

- A deeper incised channel within the main creek bed will run the length of the realigned creek and will be approximately 1 m wide with sloped sides
- Deep pools (currently designed for four) will be created to provide potential overwintering habitat areas (presently a limiting factor in this creek)
- Riffles and root wads will be installed within the creek bed to create areas for habitat to re-establish within the realigned creek and to slow the flow of the creek through this area
- A bio-engineered lined bed will be planted along the realignment outside of the arch culvert area of the realignment to provide new creek cover after construction is completed
- Work will be scheduled to avoid wet, windy and rainy periods that may increase erosion and sedimentation
- Revegetate areas with surface (i.e., terrestrial) disturbance following construction works. If there is insufficient time remaining in the growing season, the site should be stabilized (e.g., cover exposed areas with erosion control blankets to keep the soil in place and prevent erosion) and vegetated the following spring
- Revegetate streambanks and approach slopes with an appropriate native seed mix or erosion control mix

For design drawings of the creek realignment, see Appendix A.

5.3.5.3 Residual Effects

A permanent loss of 690 m² of instream habitat (i.e., resulting from the smaller footprint of the channel realignment) will result in a permanent change in habitat both instream and in the riparian zone (e.g., vegetation cover). The loss of instream habitat may require compensation and will be determined through the DFO Request for Review process. The design elements within the realignment of the creek including the deep pools, riffles, incised channel within the channel and less sedimentation, may provide better opportunities for overwintering within the creek.

Therefore, based on the design elements incorporated to the realignment of the creek, the effects the Project may have on a change in fish habitat is neutral in direction, moderate in magnitude, extend into the LAA, continuous and permanent.

5.3.6 Assessment of Change in Fish Movement, Migration and Fish Passage

5.3.6.1 Project Pathways

Fish movement and migration are important to local fish abundance to access habitat for lifecycle requirements. Isolation construction methods associated with infrastructure construction, channel realignment and in-channel enhancement work, will result in a temporary blockage or diversion of flow resulting in the blockage of fish passage for a short duration.

During construction of the Project, the creek will be temporarily diverted. When the creek is isolated for diversion, fish salvage will occur and fish will be placed downstream of PDA1. This will be done twice as the diversion of the creek will be completed in two stages to be able to access the meandering creek in sections (see Section 2.2.1.6). The temporary diversion pipe B will be installed along the eastern side of the ravine as a buried, 1200 mm corrugated steel pipe.

The pipe will be covered at the upstream and downstream extents by 3 m high berms. The purpose of these berms are twofold, they will provide the isolation component for the instream realignment and access for construction vehicles during all construction work and they will allow the creek upstream to “charge” the diversion pipe to allow for water and fish passage through the pipe during storm events, without overtopping the berm.

Once the creek is realigned and the isolation berms removed, fish movement, migration and passage will be through a wider creek, with deep pools, riffles, root wads and a deeper incised channel within the main channel. The flow of water within the new channel will be within the expected ranges of flow that existed prior to construction.

5.3.6.2 Mitigation Measures

Mitigation measures specific to reduce effects on fish movement, migration and fish passage include:

- Minimize the duration of instream work
- Conduct a rescue of fish which may be trapped within the isolated area and place downstream of isolated area
- Screen any water intake pipes during dewatering events to prevent entrainment or impingement of fish
- During pumping of water, screens will be located away from natural or artificial structures that may attract fish that are migrating, spawning, or in rearing habitat
- Regular maintenance and repair of cleaning apparatus, seals, and screens is carried out to prevent debris-fouling and impingement of fish.
- The diversion pipe, including dams or wing walls (if applicable), should be monitored and contingency measures and materials should be developed and on site in case of a failure
- Intakes should be installed in a manner that prevents the uptake or entrainment of sediment and aquatic organisms associated with the bottom area

5.3.6.3 Residual Effects

Potential effects from the Project on fish movement, migration and passage is limited to the construction phase of the Project. Once the mitigation measures are employed, the effects to fish movement, migration and passage are minimal. Once instream work and the realignment of the creek is completed, the channel will provide better opportunities for fish movement, migration and fish passage as the Project design includes a wider, deeper environment and areas for overwintering, where these currently do not exist within PDA1. Further, by providing new habitat and overwintering opportunities, other fish that exist downstream from PDA1, but not currently observed in the creek, may be able to move upstream and utilize the creek.

Therefore, based on the design elements incorporated to the realignment of the creek, the effects the Project may have on a change in fish movement, migration and passage is neutral in direction, low in magnitude, limited to the PDA, a single event and short term.

5.3.7 Assessment of Change in Fish Mortality

5.3.7.1 Project Pathways

Potential effects from the Project may increase the opportunity for fish mortality. Fish mortality may occur directly during instream work (e.g., contact with machinery, impingement on water or pump intakes, accidental removal from a watercourse or water body via construction equipment or asphyxiation because of dewatering activities), or indirectly by introduction of deleterious substance to the creek.

5.3.7.2 Mitigation Measures

Mitigation measures specific to reduce fish mortality include:

- Minimize the duration of instream work
- Conduct instream work during periods of low flow, to further reduce the risk to fish and their habitat or to allow work in water to be isolated from flows
- Conduct a fish rescue which may be trapped within the isolated area and place downstream of isolated area
- Intakes should be installed in a manner that prevents the uptake or entrainment of sediment and aquatic organisms associated with the bottom area; use of a 3 m high berm will be used
- When dewatering excavations or work areas (if required), remove suspended solids by diverting water into a vegetated area or settling basin, and prevent sediment and other deleterious substances from entering the watercourse
- Protect the outflow area to prevent erosion and the release of suspended sediments downstream, and remove this material when the works have been completed
- When removing the isolation, gradually remove the downstream dam/wing wall first, to equalize water levels inside and outside of the isolated area and to allow suspended sediments to settle

Mitigation to reduce the potential effect on the sediment load and quality of the water in the creek during Project activities include the ESC Plan. ESC measures will be implemented specific to the Project activities that are being constructed. Detailed ESC measures are outlined in Appendix F.

5.3.7.3 Residual Effects

During the isolation of the creek and the temporary diversion construction phase there is potential for limited fish mortality to occur. Fish salvage will occur during both stages of the isolation process, and fish will be released downstream from PDA1. Furthermore, by completing the isolation of PDA1 area during limited flow periods (i.e., winter), it is expected that minimum fish will be found within PDA1 as the current creek depth and habitat provide little to no overwintering areas (see Appendix D Fish and Fish Habitat Assessment).

Deleterious substances including sediment and contaminants will be limited based on the staged ESC plans for the Project. Work will be limited during periods of rain or high runoff to further reduce the potential for deleterious substances entering the creek, which can cause fish mortality.

With the application of mitigation measures, the residual effects of Project construction and operation on the changes to fish mortality are adverse in direction, low in magnitude, limited to the PDA1, considered a single event and permanent duration.

5.3.8 Summary of Residual Effects on Fisheries and Fish Habitat

A summary of Project residual environmental effects on fish and fish habitat is presented in Table 15.

Table 15 Residual Effect Characterizations for Fisheries and Fish Habitat

Residual Effect	Residual Effect Characterization				
	Direction	Magnitude	Spatial Extent	Frequency	Duration
Change in fish habitat	N	M	LAA	C	P
Change in fish movement, migration and fish passage	N	L	PDA	S	ST
Change in fish mortality	A	L	PDA	S	P
<p><u>KEY</u> Direction: P – Positive; A – Adverse; N – Neutral Magnitude: N – Negligible; L – Low; M – Moderate; H – High Spatial Extent: PDA – Project Development Area; LAA – Local Assessment Area Frequency: S – Single event; IR – Irregular event; R – Regular event; C – Continuous Duration: ST – Short-term; MT – Medium-term; LT – Long-term; P – Permanent</p>					

5.4 VEGETATION

5.4.1 Potential Effects, Pathways, and Measurable Parameters

The assessment of Project-related effects on vegetation focuses on the change in community diversity.

Table 16 presents the potential effects, effect pathways and measurable parameters for the assessment of effects on vegetation.

Table 16 Potential Effects, Effects Pathways, and Measurable Parameters for Vegetation

Potential Effect	Effect Pathway	Measurable Parameter(s) and Units of Measurement
Change in plant community diversity	Change in plant communities	Areal extent of ecological communities or vegetation types Ecological communities at risk Rare plant populations Introduction of weeds

5.4.2 Criteria for Characterizing Residual Effects

Characterizations of residual effects are defined in Table 17 Residual Effect Characterization Definitions for Vegetation.

Table 17 Residual Effect Characterization Definitions for Vegetation

Parameter	Description	Definition
Direction	Whether the residual effect is assessed to have a positive, adverse, or neutral effect on the measurable parameters of the VC	Positive – a residual effect that moves measurable parameters in a direction beneficial to the VCs relative to baseline conditions Adverse – a residual effect that moves measurable parameters in a direction detrimental to the VCs relative to baseline conditions Neutral – no net change in measurable parameters for the VCs relative to baseline
Magnitude	The amount of change in measurable parameters of the VC relative to baseline conditions	Negligible – the change in community diversity for vegetation is not measurable Low – change in community diversity for vegetation is less than 10% Moderate – change in community diversity for vegetation is more than 10% but less than 50% High – change in community diversity for vegetation is more than 50%
Spatial Extent	The spatial area in which a residual effect occurs	PDA – residual effects are restricted to the PDA LAA – residual effects extend into the LAA
Frequency	How often the residual effect occurs	Single Event – occurs only once Multiple Irregular Events – occurs at no set schedule Multiple Regular Events – occurs at regular intervals Continuous – occurs continuously

Parameter	Description	Definition
Duration	The period of time required until the measurable parameter of the VC returns to its baseline condition, or the residual effect can no longer be measured or otherwise perceived	<p>Short term – effects are measurable for less than one growing season (i.e., less than one year).</p> <p>Medium term – effects are measurable for several growing seasons, enough for vegetation seeds to be established (i.e., 2 to 20 years).</p> <p>Long term – effects are measurable for multiple for multiple growing seasons (i.e., greater than 20 years).</p> <p>Permanent – residual effect is measurable in perpetuity</p>

5.4.3 Project Interactions with Vegetation

Table 18 identifies Project activities that have the potential for effects on Vegetation. These interactions (indicated by check marks) are discussed in detail in the context of effects mechanisms, standard and Project-specific mitigation, and residual effects in Sections 5.4.4 and 5.4.5.

Table 18 Project Environment Interactions with Vegetation

Physical Activities	Potential Environmental Effects
	Change in plant community diversity
Construction	
Vegetation Clearing	✓
Creation of construction access	-
Creek isolation and pump around	-
Arch Culvert Installation	-
Backfill and Grading	-
Creek Realignment and Wildlife Passage	-
Construction of Aurum Road	-
Reclamation and revegetation	✓
Operation	
Daily use of Aurum Road	-
Final Acceptance Certificate Requirements	-
Wildlife Passage Maintenance Activities	-
<u>NOTES</u>	
✓ = Potential interaction	
- = No interaction	

5.4.4 Assessment Techniques

An assessment of residual effects to vegetation was conducted based on the plant community diversity baseline conditions in PDA1 and the total loss of plant communities in PDA2.

5.4.5 Assessment of Change in Plant Community Diversity

5.4.5.1 Project Pathways

The change in plant community diversity in PDA1 and PDA2 is limited to the vegetation clearing and reclamation and revegetation phases of construction. Vegetation removal is expected to occur throughout the entire PDA1 and PDA2 areas, a total of 2.8 ha and 0.3 ha respectively. Any edge effects will be contained within the PDAs. Reclamation and revegetation plan once construction of the Project is completed will be limited to specific areas within PDA1.

5.4.5.2 Mitigation Measures

The following mitigation measures have been developed for the Project and are expected to reduce potential effects on vegetation.

- Cleared and disturbed areas should be reclaimed as soon as possible with an approved seed mix to reduce weed establishment and erosion.
- Revegetated areas should be monitored for weeds, and an appropriate weed control plan should be developed in accordance to the number and species of weeds observed.
- Revegetation plans include a diverse planting mix that is typical in ravine habitats

Construction fencing should be set up to mark construction area boundaries and protect trees outside the boundary from root and trunk damage.

5.4.5.3 Residual Effects

While a loss of baseline vegetation will occur within PDA1, the plant community diversity overall will be enhanced through the introduction of new plant species and adding topsoil to support these plantings. The baseline conditions of the ravine are currently limited, as the supporting substrate is nutrient poor and the steep slopes limit the type of vegetation growth.

PDA2 will be permanently cleared of vegetation and replaced by roadway, a loss of less than 1% of the LAA and 10% of combined PDAs. However, PDA2 has been previously disturbed and has not been vegetatively functioning as part of the ravine system prior to the construction of the Project.

With the application of mitigation measures, the residual effects of Project construction and operation on the changes in plant community diversity are neutral in direction, moderate in magnitude, limited to the PDA, a single event and permanent in duration.

5.4.6 Summary of Residual Effects on Vegetation

A summary of Project residual environmental effects on vegetation is presented Table 19.

Table 19 Residual Effect Characterizations for Vegetation

Residual Effect	Residual Effect Characterization				
	Direction	Magnitude	Spatial Extent	Frequency	Duration
Change in plant community diversity	N	M	PDA	S	P
KEY Direction: P – Positive; A – Adverse; N – Neutral Magnitude: N – Negligible; L – Low; M – Moderate; H – High Spatial Extent: PDA – Project Development Area; LAA – Local Assessment Area Frequency: S – Single event; IR – Multiple Irregular event; R – Regular event; C – Continuous Duration: ST – Short-term; MT – Medium-term; LT – Long-term; P – Permanent					

5.5 WILDLIFE

5.5.1 Potential Effects, Pathways, and Measurable Parameters

The assessment of Project-related effects on wildlife focuses on the change in habitat, change in mortality risk and change in movement.

Table 20 presents the potential effects, effect pathways and measurable parameters for the assessment of effects on wildlife.

Table 20 Potential Effects, Effects Pathways, and Measurable Parameters for Wildlife

Potential Effect	Effect Pathway	Measurable Parameter(s) and Units of Measurement
Change in habitat	Project could result in direct and/or indirect loss or alteration of wildlife habitat	Amount (ha) of wildlife habitat directly and/or indirectly lost (e.g., sensory disturbance) or altered.
Change in mortality risk	Vehicular strikes, clearing of sites, contact with deleterious substances	Qualitative/Quantitative evaluation of direct mortality risk (may include): * Risk of mortality due to vegetation clearing, site preparation and maintenance * Risk of collisions with project vehicles (note: mortality from vehicle collisions that may occur at all project phases) (e.g., increase in annual daily traffic volumes)
Change in movement	Construction and operation of the Project could result in alteration of wildlife movement patterns (daily, seasonal) or movement corridors	Extent of area (ha) causing movement hindrance Effects of Project on movement

5.5.2 Criteria for Characterizing Residual Effects

Characterizations of residual effects are defined in Table 21 Residual Effect Characterization Definitions for Wildlife.

Table 21 Residual Effect Characterization Definitions for Wildlife

Parameter	Description	Definition
Direction	Whether the residual effect is assessed to have a positive, adverse, or neutral effect on the measurable parameters or the VC	<p>Positive – a residual effect that moves measurable parameters in a direction beneficial to wildlife relative to baseline conditions</p> <p>Adverse – a residual effect that moves measurable parameters in a direction detrimental to wildlife relative to baseline conditions</p> <p>Neutral – no net change in measurable parameters for wildlife relative to baseline</p>
Magnitude	The amount of change in measurable parameters of the VC relative to baseline conditions	<p>Negligible – No measurable change in mortality risk to wildlife anticipated. No loss or alteration of wildlife habitat or wildlife movement anticipated.</p> <p>Low – Measurable change in mortality risk and/or loss of wildlife habitat, but at levels not anticipated to have a measurable effect on local wildlife species assemblages. Some individuals may not pass through arch culvert but this is not anticipated to have a measurable effect on local wildlife species assemblages in the LAA.</p> <p>High – Measurable change in mortality risk and/or loss of wildlife habitat that are anticipated to have a measurable effect on local wildlife species assemblages. Some wildlife species may not pass through arch culvert and this is anticipated to have a measurable effect on local wildlife species assemblages in the LAA.</p>
Spatial Extent	The spatial area in which a residual effect occurs	<p>PDA – residual effects are restricted to the PDA</p> <p>LAA – residual effects extend into the LAA</p>
Frequency	How often the residual effect occurs	<p>Single Event – occurs only once</p> <p>Multiple Irregular Events – occurs at no set schedule</p> <p>Multiple Regular Events – occurs at regular intervals</p> <p>Continuous – occurs continuously</p>

Parameter	Description	Definition
Duration	The period of time required until the measurable parameter of the VC returns to its baseline condition, or the residual effect can no longer be measured or otherwise perceived	<p>Short term – effects are measurable for less than one breeding season (i.e., less than one year).</p> <p>Medium term – effects are measurable for one generation or several breeding seasons (i.e., 2 to 20 years).</p> <p>Long term – effects are measurable for multiple generations or multiple breeding seasons (i.e., greater than 20 years).</p> <p>Permanent – residual effect is measurable in perpetuity</p>

5.5.3 Project Interactions with Wildlife

Table 22 identifies Project Environment Interactions with Wildlife activities that have the potential for effects on wildlife. These interactions (indicated by check marks) are discussed in detail in the context of effects mechanisms, standard and Project-specific mitigation, and residual effects in Sections 5.5.4 and 5.5.5.

Table 22 Project Environment Interactions with Wildlife

Physical Activities	Potential Environmental Effects		
	Change in habitat	Change in mortality risk	Change in movement
Construction			
Vegetation Clearing	✓	✓	✓
Creation of construction access	–	✓	–
Creek isolation and pump around	–	–	–
Arch Culvert Installation	✓	✓	–
Backfill and Grading	–	✓	–
Creek Realignment and Wildlife Passage	–	–	✓
Construction of Aurum Road	✓	✓	–
Reclamation and revegetation	✓	–	✓
Operation			
Daily use of Aurum Road	–	✓	–
Final Acceptance Certificate Requirements	–	–	–
Wildlife Passage Maintenance Activities	–	–	✓
NOTES			
✓ = Potential interaction			
– = No interaction			

5.5.4 Assessment Techniques

An assessment of residual effects to wildlife was determined by comparing species composition of wildlife in, and likely in, the LAA and their habitat associations at different times throughout the year. Field supported assessments of amphibians and breeding birds, including incidental wildlife observations were completed in the LAA to further understand the potential for interactions between Project phases and activities with wildlife (see Appendix C Wildlife TDR). An additional assessment was completed to evaluate the potential for the proposed arch culvert and wildlife passage to facilitate passage of Ecological Design Groups (EDGs) predicted to occur in the area (see Appendix G Clover Bar Creek Crossing at Aurum Road: Evaluation of Wildlife Passage).

5.5.5 Assessment of Change in Habitat

5.5.5.1 Project Pathways

Vegetation clearing is expected to cause the largest change in wildlife habitat available within the PDAs. Vegetation clearing will result in the removal of 2.8 ha from PDA1 of mainly aspen woodland alliance, aspen poplar woodland alliance, and a short shrub alliance. Many different wildlife species utilize this habitat and the loss of habitat may displace wildlife to habitat outside of the PDA1 into the LAA. Assessment of residual effects to wildlife in PDA2 was not evaluated as the area has already been altered over time by agricultural use and industrial development.

Habitat use by wildlife may also be altered by construction of the Project, due to fragmentation, reduction of habitat patch size, creating edges along the Project PDA1 perimeter and linear facilities (e.g., roads). However, the remaining woodland habitat parcels within the LAA are separated from the PDA1 by existing edges (i.e., roads or pipeline ROWs). As such, no changes in use of wildlife habitat are anticipated due to fragmentation.

5.5.5.2 Mitigation Measures

The following mitigation measures will be implemented to minimize the potential effects of change in habitat:

- The Project footprint will be minimized. Unnecessary vegetation clearing will be avoided wherever practicable
- Natural substrate and native vegetation should be placed at the approaches to the crossing structure. These will create a more natural appearance around the structure and, for smaller EDGs, provide security cover from predators

5.5.5.3 Residual Effects

The construction and operation of the Project will result in a change in available habitat, as a loss of 2.8 ha habitat in PDA1 will occur, 4% of available habitat within the LAA. Some of this area will be revegetated with plants that are attractive to the types of wildlife that exists in the LAA.

With the application of mitigation measures, the residual effects of Project construction and operation on the changes in habitat are adverse in direction, low in magnitude, limited to the PDA, continuous and permanent in duration.

5.5.6 Assessment of Change in Mortality Risk

5.5.6.1 Project Pathways

An increase in mortality risk is expected through potential interactions with equipment or Project activities. Vegetation clearing, creation of construction access, backfill and grading, arch culvert installation and Aurum Road construction might cause wildlife mortality based on the increased presence of vehicles, removal of vegetation in use by wildlife and occupied dens or nests that might be incidentally destroyed. Wildlife species that cannot move quickly from areas being cleared are more likely to be affected, such as small mammals and herptiles. During construction, once clearing of the vegetation is completed, it is anticipated that the mortality risk will decrease, as wildlife will be less attracted to the PDAs based on limited habitat availability. Mortality risk will also be higher during the operational phase than previously as there will be an active roadway in place.

5.5.6.2 Mitigation Measures

The following mitigation measures will be implemented to minimize the potential effects of direct mortality:

- The Project footprint will be minimized. Unnecessary vegetation clearing will be avoided wherever practicable
- Avoid construction activities with the potential to remove wildlife habitat during the breeding season (end of March to end of August). Should vegetation clearing activities be unavoidable during this window, a program will be implemented to reduce and avoid effects on birds and their nests including nest surveys
- Implement and enforce speed limits for vehicles on access roads
- During construction, the use of site flood lighting during the migration periods (i.e., April to May and late August through October) will be limited
- Use natural vegetation and tree plantings to direct the flight paths of birds and bats higher over the road, above the traffic (Tremblay 2006).
- Tree plantings should be designed to grow taller than the highest vehicles using the road
- Consideration should be given to installing taller street lights. Since large numbers of insects typically gather near light sources, installation of taller lights should direct bats to fly higher and thereby avoid vehicle collisions
- Installation of wildlife fencing along the MSE walls to limit wildlife movement over Aurum Road, through the ravine

5.5.6.3 Residual Effects

The construction and operation of the Project could result in a change in mortality risk. However, the implementation of applicable mitigation measures is expected to reduce or eliminate most pathways for this effect.

With the application of mitigation measures, the residual effects of Project construction and operation on the change in mortality risk is adverse in direction, low in magnitude, limited to the PDA, a single event and permanent in duration.

5.5.7 Assessment of Change in Movement

5.5.7.1 Project Pathways

Change in movement can occur directly through the creation of movement barriers and indirectly through sensory disturbance. Both of these processes disrupt habitat connectivity and reduce landscape permeability. During construction, vegetation clearing will occur for all of both PDAs, with the potential for altering wildlife movement within the area or avoidance of the ravine itself.

Sensory disturbance caused by Project activities during construction or by vehicle traffic after the Project completion may also result in some species avoiding the PDAs.

5.5.7.2 Mitigation Measures

The wildlife passage under the arch culvert has been designed as a mitigation measure to address potential adverse effects to wildlife movement. Wildlife Passage Engineering Guidelines (Stantec 2010b) were followed for the Project. Passage requirements for 11 EDGs: Large Terrestrial, Medium Terrestrial, Small Terrestrial, Amphibians, Aerial Mammals, Aquatic Species, Scavenger Birds, Birds of Prey, Water Birds, Ground Dwelling Birds, and Other Birds (City of Edmonton 2010) are addressed by the crossing structure design. A separate report for the evaluation of the wildlife passage was completed to inform the design of this crossing and has been attached in Appendix G. This document lists several mitigation measures that must be implemented to reduce the potential effects on wildlife, including:

- The Project footprint will be minimized. Unnecessary vegetation clearing will be avoided wherever practicable
- Natural substrate and native vegetation should be placed at the approaches to the crossing structure. These will create a more natural appearance around the structure and, for smaller EDGs, provide security cover from predators
- Use natural vegetation and tree plantings to direct the flight paths of birds and bats higher over the road, above the traffic (Tremblay 2006). This measure will also minimize the reduction in habitat created by the road right-of-way, and maintain the aesthetics of the area

5.5.7.3 Residual Effects

Residual effects for movement of wildlife based on Project activities are anticipated to be low. The wildlife passage as designed, is considered adequate to allow effective passage of the Large Terrestrial, Medium Terrestrial, Small Terrestrial, and Ground Dwelling Birds EDGs, as well as Amphibian and Aquatic Species EDGs (see Appendix G). While it is anticipated it may take time for various animals to become habituated to the passage, the passage has been designed to facilitate the movement of all 11 EDGs. Revegetation at the openings of the upstream and downstream of the arch culvert is designed to provide cover and facilitate the movement of wildlife through the passage. Fencing along the MSE walls will restrict access over the arch culvert by wildlife, further encouraging the use of the wildlife passage under the road.

Indirect changes to movement based on sensory disturbance are expected to be limited to construction, which is short term in duration. The surrounding areas bordering the LAA (and ravine) include industrial developments, vehicle traffic, and rail traffic; to which wildlife within the LAA are habituated. Once the wildlife passage is completed, the movement of wildlife through the ravine system will be directed towards the bottom of the ravine, away from the activities that create the sensory disturbance potential pathways.

With the application of mitigation measures, the residual effects of Project construction and operation on the change in movement of wildlife is adverse in direction, low in magnitude, extends to the LAA, and is continuous and permanent in duration.

5.5.8 Summary of Residual Effects on Wildlife

A summary of Project residual environmental effects on wildlife is presented in Table 23.

Table 23 Residual Effect Characterizations for Wildlife

Residual Effect	Residual Effect Characterization				
	Direction	Magnitude	Spatial Extent	Frequency	Duration
Change in habitat	A	L	PDA	C	P
Change in mortality risk	A	L	PDA	S	P
Change in movement	A	L	LAA	C	P
<p><u>KEY</u> Direction: P – Positive; A – Adverse; N – Neutral Magnitude: N – Negligible; L – Low; M – Moderate; H – High Spatial Extent: PDA – Project Development Area; LAA – Local Assessment Area Frequency: S – Single event; IR – Multiple Irregular event; R – Regular event; C – Continuous Duration: ST – Short-term; MT – Medium-term; LT – Long-term; P – Permanent</p>					

5.6 HISTORICAL RESOURCES

5.6.1 Potential Effects, Pathways, and Measurable Parameters

In Alberta, historical resources are protected under the *Historical Resources Act* and are defined as precontact, historic and palaeontological sites and their contents. Certain types of Aboriginal traditional use sites are also considered to be historical resources.

Precontact archaeological sites include remains (e.g., stone tools, butchered bones, fire-broken rock and features such as hearths) resulting from the traditional occupation of Alberta by Aboriginal people before contact with European traders in the late 1700s. Historic archaeological sites include Aboriginal and non-Aboriginal sites, and date from the time of European contact until approximately 1960. Historic period sites include structures (e.g., homesteads, cabins and forts), artifacts (e.g., industrial and folk-manufactured items made of metal, glass, ceramic, stone and other materials) or features (e.g., trails, foundations, depressions and campsites). Palaeontological sites are areas where fossils of ancient animals or plants have been preserved.

The environmental assessment of historical resources considers the loss or alteration of historical resource sites and objects. These environmental effects have been selected in recognition of the requirements to consider effects on historical resources as defined in the *Historical Resources Act (HRA)* under the requirements set out by ACT.

Any Project activity that includes surface or subsurface ground disturbance has the potential for interaction with historical resources. Project construction therefore has the greatest potential for interaction with historical resources, because it includes the majority of the initial earthworks. It is not anticipated that there will be any additional ground disturbance during the operation phase of the project. Therefore, the assessment of effects addresses the construction phase of the project exclusively.

Table 24 Potential Effects, Effects Pathways, and Measurable Parameters for Historical Resources

Potential Effect	Effect Pathway	Measurable Parameter(s) and Units of Measurement
Unauthorized disturbance or destruction of part or all of historical resource	Removal or disturbance of historical resource through vegetation removal or surface/subsurface disturbance.	Change in heritage value of historical resource sites

5.6.2 Criteria for Characterizing Residual Effects

This section considers residual effects on historical resources after the application of required mitigation. Site-specific mitigation of project effects on historical resources is provincially

regulated. ACT independently assesses the heritage value of historic resource sites, determines the need for, and scope of, mitigation measures, and issues project approval under the *HRA*. Since project-specific environmental effects on historical resources are continually mitigated to the standards established by ACT, after implementation of the required mitigation measures, and Aboriginal consultation, there are considered to be no residual environmental effects. With the application of regulatory standards, there will be no residual effects of the Project on historical resources.

5.6.3 Project Interactions with Archaeological and Historical Resources

Table 25 identifies, for each potential effect, the Project’s physical activities that might interact with historical resources. These interactions are indicated by check marks, and are discussed in detail in Section 5.6.4 in the context of effects pathways, standard and project-specific mitigation.

Table 25 Project Environment Interactions with Historical Resources

Physical Activities	Environmental Effects
	Unauthorized disturbance or destruction of part or all of an archaeological site or sites
Construction	
Vegetation Clearing	✓
Creation of construction access	✓
Creek isolation and pump around	-
Arch Culvert Installation	✓
Installation of Wildlife Passage	-
Backfill and Grading	-
Creek Realignment and Wildlife Passage	-
Construction of Aurum Road	-
Reclamation and revegetation	-
Operation	
Daily use of Aurum Road	-
Final Acceptance Certificate Requirements	-
Wildlife Passage Maintenance Activities	-
<u>NOTES</u>	
✓ = Potential interaction	
- = No interaction	

5.6.4 Analytical Methods

The assessment was initiated with a desktop review. The *Listing of Historic Resources* (ACT 2015, September edition) was reviewed to identify listed lands with palaeontological and archaeological sensitivity/sites. A site file search of all known historical resource sites within the LAA was obtained from ACT. All previous historical resource studies conducted within the LAA were reviewed. Aerial imagery, 1:50,000 scale topographic maps and geology maps were consulted. Local community histories and the Western Land Grants database (1884b) were consulted to provide historic homestead information.

The results of the desktop review were summarized in a regulatory screening document, known as a Statement of Justification (SoJ), and submitted to ACT for regulatory review (Stantec 2016d). The SoJ was submitted to ACT, attached to an online Historic Resources Application. The purpose of the SoJ is to present the scope of the proposed development and the results of the desktop review to ACT in order for them to determine whether field assessments (HRIAs) are required. ACT reviewed the SoJ and issued requirement letters to Aurum Industrial Development Partnership for HRIAs for archaeology and palaeontology (HRA Requirements 4835-08-0047).

The HRIAs (field assessments) were undertaken in 2016. The archaeology assessment was conducted under permit 16-182 (Porter 2016) and consisted of surface inspection and shovel testing of areas of high and moderate archaeological potential. Sites were assessed, photographed, and documented according to provincial guidelines. The palaeontology assessment was conducted under permit 16-080 (Stantec 2016c). Natural exposures were examined within the ravine and access road cuts. The geology and fossil content of the exposures were documented. Each palaeontological site was photographed and described and a UTM coordinate was recorded.

The palaeontology HRIA report has been submitted to ACT in fulfillment of the permit requirements. The archaeology HRIA report will be submitted to ACT; this is anticipated to occur in early 2017. ACT will review the reports and determine whether the assessment is complete and issue additional requirements for avoidance or mitigation of any sites determined to be of high heritage value. Construction monitoring may also be required. Because ACT considers site information to be confidential, the reports are not included as part of this filing.

5.6.5 Existing Conditions

Existing conditions for historical resources were determined through desktop review and field assessments for archaeology and palaeontology and are described in detail in the HRIA reports (Stantec 2016c; Stantec 2016e). Assessment of Unauthorized disturbance or destruction of part or all of an archaeological site(s)

5.6.5.1 Project Pathways

Any historical resource sites identified during field survey located within the limits of the PDA may be affected during construction activities including vegetation clearing, creation of construction access, and ravine slope modifications and creek realignment.

5.6.5.2 Mitigation Measures

The objective of the mitigation is to limit the loss of historical resources or site integrity due to Project-related activities. The best mitigation option is avoidance and protection of the resource(s). This can occur through Project redesign, excluding the historical resource site area from the Project, or incorporating the area of the historical resource site into the Project footprint but without alteration. Any of these avoidance options might require the installation of a protective barrier around the site and a buffer zone.

If avoidance and protection of historical resources is not feasible then controlled collection of fossils, controlled salvage excavations of archaeological resources, or parts thereof as applicable, or construction monitoring may be required. These mitigative actions will be determined by ACT and issued as requirements under the *Historical Resources Act*.

5.6.5.3 Residual Effects

As project specific environmental effects on archaeological resources are continually mitigated to the standards set by the regulatory agency, after implementation of the mitigation measures, there will be no residual environmental effects.

6.0 SUMMARY OF ASSESSMENT OF POTENTIAL ENVIRONMENTAL EFFECTS

This section will provide a summary of the following information:

- potential environmental effects
- proposed mitigation measures to address the effects identified in Section 5.0
- potential residual effects after mitigation measures are applied
- characterization of the potential residual effects

The detailed assessment of the valued components is provided in Section 5.0. The following table provides a summary for the identified valued components, which are as follows:

- Viewscape
- Surface Water
- Fisheries and Fish Habitat
- Vegetation
- Wildlife
- Historical Resources

Table 26 Summary of Potential Environmental Effects Assessment

Valued Component Affected	Project Phase		Potential Effects	Proposed Mitigation Measures	Residual Effects	Direction	Magnitude	Spatial Extent	Frequency	Duration
	Construction	Operation								
Viewscape	✓	✓	<ul style="list-style-type: none"> Change in Viewscape 	<ul style="list-style-type: none"> Minimize the disturbance as much as possible to the final footprint of the PDA1 and PDA2 Complete the Project construction within the proposed timeframe and reclaim and revegetate the ravine as soon as possible Use plantings and vegetation that will minimize the arch culvert structure to the extent possible Diversify the vegetation that is currently within Clover Bar Ravine, in order to propagate seed distribution and enhance vegetation growth, as the natural growth in the ravine has been limited based on the poor quality of the soils and limited nutrients available for plant propagation 	<ul style="list-style-type: none"> Installation of the Project will change the view within the ravine 	A	L	PDA	C	P
Surface Water	✓	-	<ul style="list-style-type: none"> Change in sediment load and water quality 	<ul style="list-style-type: none"> Implement the ESC plan Complete instream works during low flow or frozen conditions Construct swales and sediment forebays to direct surface flows during construction and during operation of the arch culvert Implement good fueling practices to prevent contamination of water courses and sensitive areas Installation of a stormwater management system Install riffles, deep pools and root wads within the realigned creek Use berms to "charge" the temporary diversion pipe, to ensure overflow of surface water or the creek into isolated creek areas during construction 	<ul style="list-style-type: none"> No residual effects to water quality and hydraulics of Creek Water may pool during heavy rain events upstream of Aurum Road in PDA2 	N	L	LAA	S	ST
			<ul style="list-style-type: none"> Change in hydraulics of Clover Bar Creek and the western dry ravine 			N	N	LAA	C	P
Fish and Fish Habitat	✓	✓	<ul style="list-style-type: none"> Change in fish habitat 	<ul style="list-style-type: none"> Limit instream work until the creek has been isolated Complete fish salvage during diversion of the creek Complete work during low flow periods, until the creek has been isolated Screen any water intake pipes on pumps Implement ESC measures as per the ESC Plan Design of the creek realignment area to include deep pools, riffles, root wads and wider and incised channel Use bio-engineering edge and planting along realignment of the creek Implement setback requirements or secondary containment protocols for activities such as equipment refueling and maintenance 	<ul style="list-style-type: none"> Loss of 690 m2 of creek area Creation of deep pools, riffles, root wads and wider and incised channel 	N	M	LAA	C	P
			<ul style="list-style-type: none"> Change in fish movement, migration and fish movement 			N	L	PDA	S	ST
			<ul style="list-style-type: none"> Change in fish mortality 			A	L	LAA	S	P

AURUM ROAD ENVIRONMENTAL IMPACT ASSESSMENT, EDMONTON, ALBERTA

Summary of Assessment of Potential Environmental Effects
April 2017

Valued Component Affected	Project Phase		Potential Effects	Proposed Mitigation Measures	Residual Effects	Direction	Magnitude	Spatial Extent	Frequency	Duration
	Construction	Operation								
Vegetation	✓	✓	<ul style="list-style-type: none"> Change in plant community diversity 	<ul style="list-style-type: none"> Cleared and disturbed areas should be reclaimed as soon as possible with an approved seed mix to reduce weed establishment and erosion Revegetated areas should be monitored for weeds, and an appropriate weed control plan should be developed in accordance to the number and species of weeds observed Revegetation plans include a more diverse planting mix that is typical in ravine habitats 	<ul style="list-style-type: none"> Loss of 2.8 ha of native vegetation in PDA1 Loss of 0.3 ha of agricultural land in PDA2 Diversify the vegetation communities within PDA1 	N	M	PDA	S	P
Wildlife	✓	✓	<ul style="list-style-type: none"> Change in habitat 	<ul style="list-style-type: none"> Installation of the arch culvert and wildlife passage The Project footprint will be minimized, vegetation clearing will be avoided wherever practicable Natural substrate and native vegetation should be placed at the approaches to the crossing structure. These will create a more natural appearance around the structure and, for smaller EDGs, provide security cover from predators Use natural vegetation and tree plantings to direct the flight paths of birds and bats higher over the road, above the traffic (Tremblay 2006). This measure will also minimize the reduction in habitat created by the road right-of-way, and maintain the aesthetics of the area 	<ul style="list-style-type: none"> Change in vegetation will result in a change in habitat and amount available Mortality of wildlife may occur Wildlife passage will allow for the free movement of wildlife under Aurum Road 	A	L	PDA	C	P
			<ul style="list-style-type: none"> Change in mortality risk 	<ul style="list-style-type: none"> Tree plantings should be designed to grow taller than the highest vehicles using the road Consideration should be given to installing taller street lights. Since large numbers of insects typically gather near light sources, installation of taller lights should direct bats to fly higher and thereby avoid vehicle collisions. The Project footprint will be minimized. Unnecessary vegetation clearing will be avoided wherever practicable Avoid construction activities with the potential to remove wildlife habitat during the breeding season (end of March to end of August). Should vegetation clearing activities be unavoidable during this window, a program will be implemented to reduce and avoid effects on birds and their nests 		A	L	PDA	S	P
			<ul style="list-style-type: none"> Change in movement 	<ul style="list-style-type: none"> Implement and enforce speed limits for vehicles on access roads During construction, the use of site flood lighting during the migration periods (i.e., April to May and late August through October) will be limited If sensitive wildlife features (e.g. dens, nests) are identified in pre-construction surveys or during construction, implement best management practices including setback areas around locations as recommended by a qualified professional Remove fencing around construction area when construction is complete to reduce effects to connectivity Tree plantings should be designed to grow taller than the highest vehicles using the road Consideration should be given to installing taller street lights. Since large numbers of insects typically gather near light sources, installation of taller lights should direct bats to fly higher and thereby avoid vehicle collisions 		A	L	LAA	C	P

AURUM ROAD ENVIRONMENTAL IMPACT ASSESSMENT, EDMONTON, ALBERTA

Summary of Assessment of Potential Environmental Effects
April 2017

Valued Component Affected	Project Phase		Potential Effects	Proposed Mitigation Measures	Residual Effects	Direction	Magnitude	Spatial Extent	Frequency	Duration
	Construction	Operation								
Historical Resources	✓	-	<ul style="list-style-type: none"> Unauthorized disturbance or destruction of part or all of an archaeological site or sites 	<ul style="list-style-type: none"> Avoidance and protection of the resource(s). This can occur through Project redesign, excluding the historical resource site area from the Project, or incorporating the area of the historical resource site into the Project footprint but without alteration. Any of these avoidance options might require the installation of a protective barrier around the site and a buffer zone If avoidance and protection of historical resources is not feasible then controlled collection of fossils, controlled salvage excavations of archaeological resources, or parts thereof as applicable, or construction monitoring may be required. These mitigative actions will be determined by ACT and issued as requirements under the Historical Resources Act 	<ul style="list-style-type: none"> No residual effects 	-	-	-	-	-
<p>KEY Direction: P – Positive; A – Adverse; N – Neutral Magnitude: N – Negligible; L – Low; M – Moderate; H – High Spatial Extent: PDA – Project Development Area; LAA – Local Assessment Area Frequency: S – Single event; IR – Multiple Irregular event; R – Regular event; C – Continuous Duration : ST – Short-term; MT – Medium-term; LT – Long-term; P – Permanent</p>										

Monitoring
April 2017

7.0 MONITORING

During the December 6, 2016 meeting between Stantec and the City of Edmonton, it was suggested that monitoring of the wildlife passage may be warranted following its construction. Should this monitoring be undertaken, it is recommended that it occur after issuance of FAC to allow the landscaping time to establish, and wildlife to become acclimated to the presence of the passage structure once human presence in the lower ravine diminishes. Monitoring can provide useful information to understand the use of the crossing by wildlife, providing insight on how urban habituated wildlife respond to passage structures of this type, size and length. Monitoring could be completed in different ways including:

- Installation of wildlife cameras upstream and downstream of the wildlife passage openings
- For medium and large EDGs - Winter tracking assessments
- For smaller EDGs - Track pad deployment

8.0 LIMITATIONS AND QUALIFICATIONS

In conducting the investigation and rendering our conclusions, Stantec gives the benefit of its best judgment based on its experience and in accordance with generally accepted professional standards for this type of investigation. This report was submitted with the best information to date and on the information provided. The conclusions made within this report are a professional opinion, not a certification of the Study Area's environmental condition, and no other warranty, expressed or implied, is made. This report has been prepared for the exclusive use of the Proponent for the purposes of assessing the current state of PDA1 and PDA2. Stantec accepts no responsibility for damages, if any, suffered by any other third party as a result of decisions made or actions based on this report. Our conclusions are limited by the following:

- Vegetation and wildlife surveys were completed during the dates specified and conditions may vary outside those times
- Field surveys to verify the presence of species listed within ACIMS and/or FWMIS databases were conducted for the LAA on the dates specified and presence or absence of said species outside of the survey dates cannot be verified
- Some of the information contained within this report was provided by agencies and organizations external to Stantec. While Stantec cannot guarantee the information provided by external parties, this information has been assumed to be correct
- The information contained within this report is based on the design available at the time of report preparation. Design drawings may continue to be modified and added as the detailed design process continues, but are intended to not depart significantly from the information presented in this report. Should significant changes to the drawings be made in the future, an amendment to this report may be required
- The investigation was limited to those parameters specifically outlined in this report

AURUM ROAD ENVIRONMENTAL IMPACT ASSESSMENT, EDMONTON, ALBERTA

Limitations and Qualifications
April 2017

- The Contractor will be responsible for determining the ultimate construction schedule and means of construction for the Project; however, should significant changes to construction timing and/or methodology from that presented within this report be proposed or required, it is the responsibility of the Contractor to confirm with all applicable regulatory agencies or bodies that this is acceptable. It is also the responsibility of the contractor to obtain all applicable amendments to approvals and/or permits that may have previously been obtained based on the information presented within this report



Prepared by _____
(signature)

Elaine Little, B.Sc.

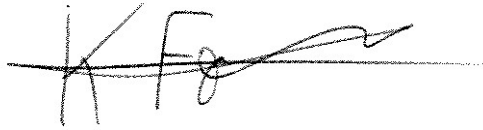

Reviewed by _____
(signature)

Kurtis Fouquette, P.Ag., P.Biol

References
April 2017

9.0 REFERENCES

- Alberta Environment and Sustainable Resource Development (ESRD). 2013. Code of Practice for Watercourse Crossings. Consolidated to include amendments as of June 24, 2013. Alberta Queen's Printer, Edmonton, AB.
- Alberta Environment and Parks (AEP). 2016. Access FWMIS data. Accessed May 2016. <<http://esrd.alberta.ca/fish-wildlife/fwmis/access-fwmis-data.aspx>>
- AMEC Foster Wheeler Environment and Infrastructure (AMEC Foster Wheeler). 2015. 17 Street NE Clover Bar Ravine Wildlife Passage Study. Prepare for the City of Edmonton, Edmonton, Alberta.
- Buehler, D.A. 2000. Bald Eagle (*Haliaeetus leucocephalus*), The Birds of North America Online (A. Poole, Ed.). The Birds of North America Online. Accessed May 2016. <<http://bna.birds.cornell.edu/bna/species/506> doi:10.2173/bna.506>
- Canadian Council of Ministers of the Environment (CCME). 2002. *Canadian Water Quality Guidelines for the Protection of Aquatic Life*. Dissolved Oxygen (Freshwater). Canadian Environmental Quality Guidelines. Canadian Council of Ministers of the Environment.
- City of Edmonton. 2000. A Guide to Environmental Review Requirements in the North Saskatchewan River Valley and Ravine System. Edmonton, Alberta.
- City of Edmonton. 2008. *Biodiversity report*. City of Edmonton. Edmonton.
- City of Edmonton. 2010. Wildlife passage engineering design guidelines. Report prepared by Stantec Consulting Ltd. for the Office of Natural Areas, City of Edmonton, AB. 249 pp. Accessed October 14, 2015, from: http://www.edmonton.ca/city_government/documents/PDF/WPEDG_FINAL_Aug_2010.pdf
- City of Edmonton. 2013. Aurum Road 17 Street NE to the Transportation Utility Corridor: Preliminary Design Report. Edmonton, Alberta.
- City of Edmonton. 2014. North Saskatchewan River Valley Area Redevelopment Plan, Bylaw 7188. Edmonton, Alberta.
- City of Edmonton, 2014. Aurum Road 17 Street NE to the Transportation Utility Corridor, Preliminary Design Report. Edmonton, Alberta.
- EGS 1993. Edmonton Beneath our Feet: A Guide to the Geology of the Edmonton Region. Godfrey, J. D. Editor. Edmonton Geological Society. Edmonton, Alberta.

AURUM ROAD ENVIRONMENTAL IMPACT ASSESSMENT, EDMONTON, ALBERTA

References

April 2017

- EPEC Consulting Western Ltd. 1981. *North Saskatchewan River valley and ravine system biophysical study*. Edmonton.
- ESRD. 2015. *Recommended land use guidelines: Key Wildlife and Biodiversity Zones*. Accessed May 2016. <<http://aep.alberta.ca/fish-wildlife/wildlife-land-use-guidelines/documents/KeyWildlifeBiodiversityZones-Apr08-2015.pdf>>
- Geowest Environmental Consultants Ltd.(Geowest). 1993. *Inventory of Environmentally Sensitive and Significant Natural Areas*. Edmonton, Alberta. 388 pp.
- Kathol, C.P. and R. A. McPherson, 1975. *Urban Geology of Edmonton*. Alberta Research Council, Bulletin 32. Edmonton, Alberta. 83 pp.
- Library and Archives Canada. 2016. *Land Grants of Western Canada, 1870-1930*. Accessed July 2016. Available at: <http://www.bac-lac.gc.ca/eng/discover/land/land-grants-western-canada-1870-1930>.
- Minni, S. 1989. Final Report, Historical Resources Impact Assessment, Edmonton Waste Management Centre, Permit 89-27. Consultant's report on file at Historic Resources Management Branch. Edmonton, AB.
- Natural Regions Committee (NRC). 2006. *Natural regions and subregions of Alberta*. Compiled by D.J. Downing and W.W. Pettapiece. Government of Alberta. Edmonton.
- Spencer, R.B. 1976. *A study of the wildlife of four selected Edmonton ravines and of the recreation uses and preferences for city ravines*. M.Sc. Thesis, University of Alberta. Edmonton.
- Spencer Environmental Management Services Ltd (Spencer). 2014. *Aurum Road Clover Bar Ravine Crossing Wildlife Movement and Wetland Analysis*. Prepared for the City of Edmonton, Edmonton, Alberta.
- Stantec 2007. *Big Lake Neighbourhood One ecological design report*. Edmonton.
- Stantec 2008. *Phase 1 Ecological Network Report (Revised): Aurum Industrial Business Parks, Area Structure Plan*. Prepared for the City of Edmonton, Edmonton, AB.
- Stantec. 2014a. *Environmental Impact Assessment for the Terwillegar Park Footbridge and Recreational Trail within portions of 3-, 10-, 11-, 14- and 15-52-25 W4M Edmonton Alberta*. Prepared for the City of Edmonton.
- Stantec. 2014b. *Pre-disturbance nest survey results for Aurum*. Correspondance.
- Stantec 2016a. *Vegetation Technical Data Report prepared for Aurum Industrial Development Park Partnership*. Edmonton, AB.

AURUM ROAD ENVIRONMENTAL IMPACT ASSESSMENT, EDMONTON, ALBERTA

References

April 2017

Stantec 2016b. Wildlife Technical Data Report prepared for Aurum Industrial Development Park Partnership. Edmonton, AB.

Stantec 2016c. Historical Resources Impact Assessment for Palaeontology, Aurum Energy Park, Permit Number 16-080, Final Report. Consultant's report on file at Royal Tyrrell Museum of Palaeontology. Drumheller, AB.

Stantec 2016d. Statement of Justification for Aurum Energy Park (incl. roadway, stormwater management, industrial subdivision). Consultant's report on file at Historic Resources Management Branch. Edmonton, AB.

Stantec 2016e. Historical Resources Impact Assessment, Aurum Energy Park, Aurum Industrial Development Partnership, Permit Number: 16-182, Final Report. Draft report on file, Stantec Consulting Ltd. Calgary, AB.

Stantec 2017. Preliminary Engineering Design Report, Aurum Road Crossing Over Clover Bar Creek, AB. Prepared for Focus Equities Albert Inc. Edmonton, AB.

Tremblay, M. 2006. Assessing functional landscape connectivity for songbirds in an urban environment. In, C. L. Irwin, P. Garrett, and K. P. McDermott (Ed.), Proceedings of the 2005 International Conference on Ecology and Transportation (pp. 563-564). Centre for Transportation and the Environment, North Carolina State University, Raleigh, North Carolina.

UMA Engineering. 2008. City of Edmonton Clover Bar Creek Storm PAC Development. Edmonton, Alberta.

APPENDIX A FIGURES

2016/12/16 8:28 AM By: Hornbeck, Selwyn
V:\1161\Active\1161104130\project_resource\Aurum Road_ER Stm Route.dwg

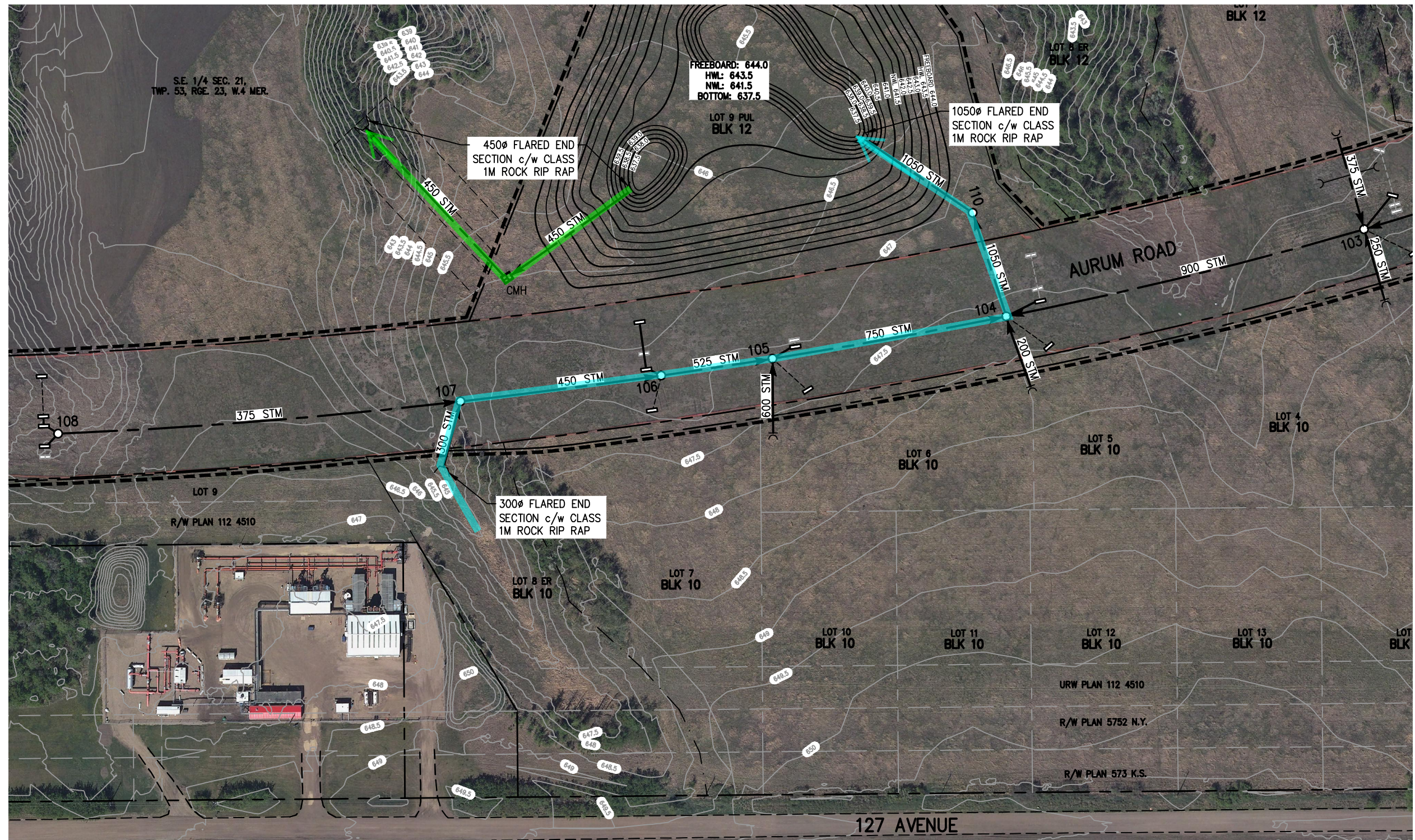

DEC, 2016
1161104130



10160 - 112 Street
Edmonton AB Canada
www.stantec.com

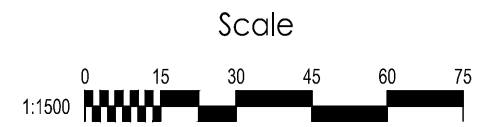

Client/Project
AURUM INDUSTRIAL DEVELOPMENT PARTNERSHIP
AURUM ENERGY PARK

Figure No.
1.0

Title
ER SITE
STORM DRAINAGE SYSTEM

Enclosure I

LDA16-0520

LEGEND

— 1.8 m ht chain link fence

Note: Wildlife fencing locations are not shown and will be determined in the EIA report and approved with Engineering Drawings

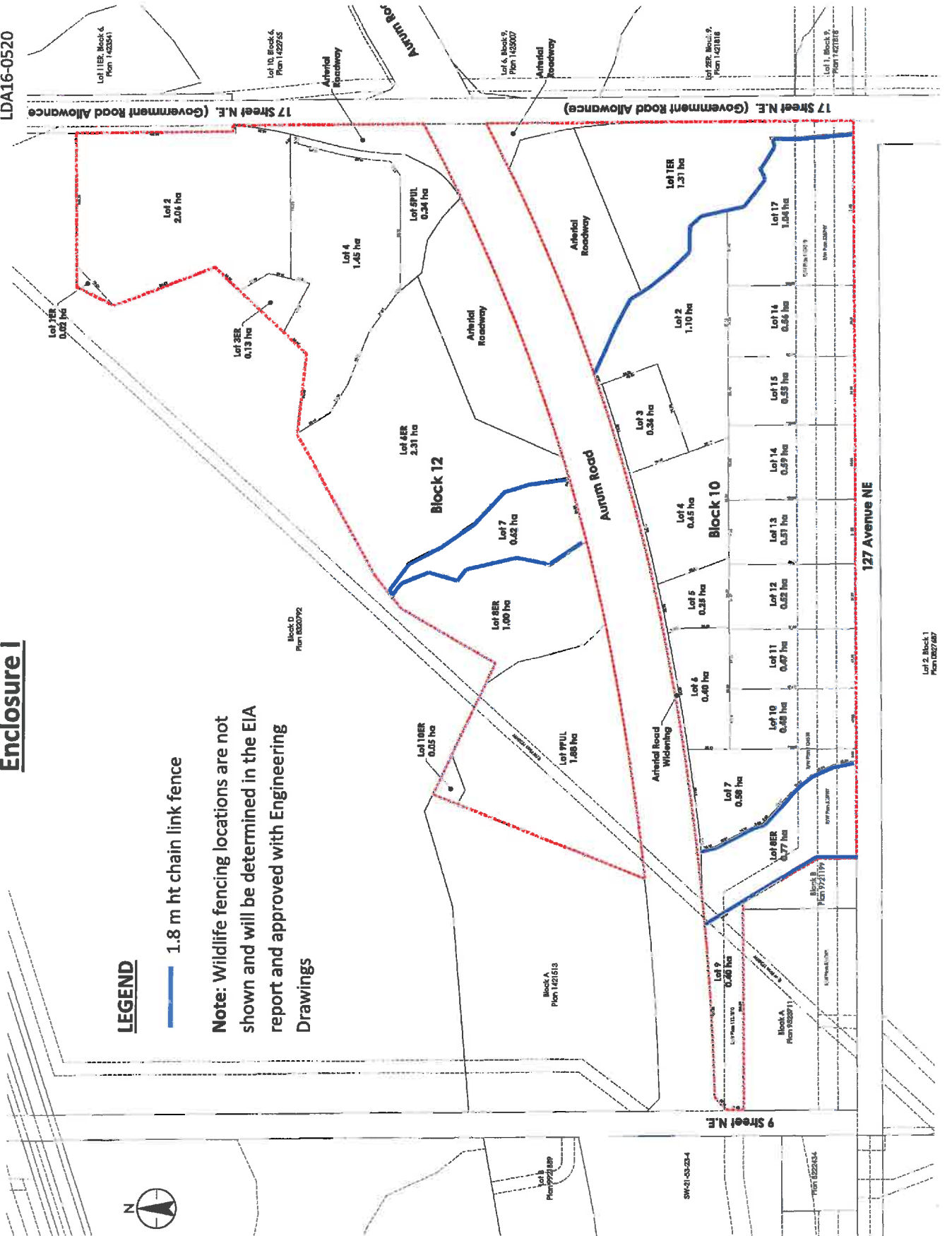

Lot 2, Block 1
Plan 1422740

127 Avenue NE

17 Street N.E. (Government Road Allowance)

Anum Road

9 Street N.E.



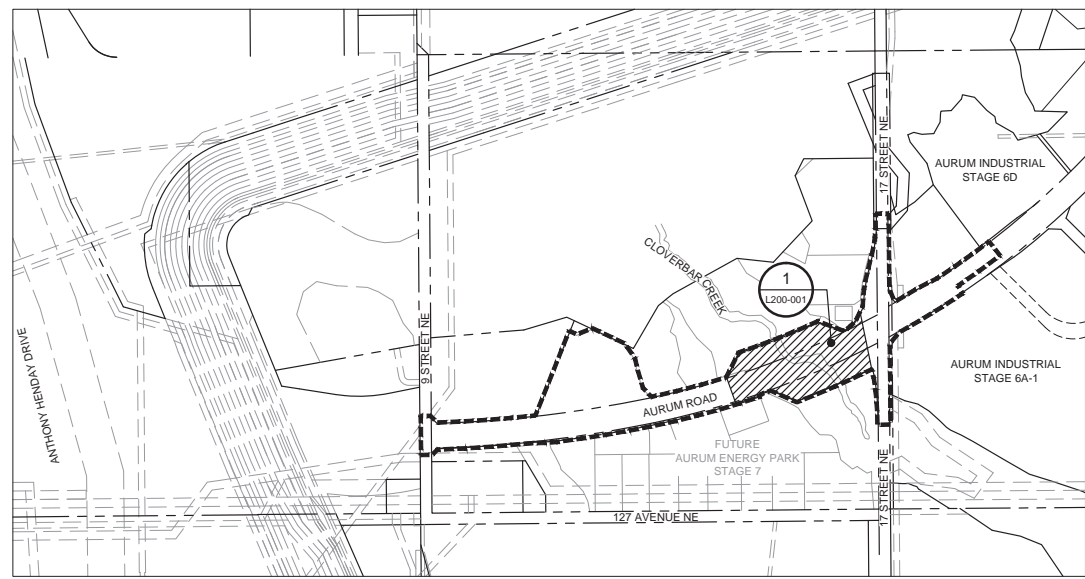

KEY PLAN
SCALE: N.T.S.

LAYOUT AND GRADING NOTES:

- CONTRACTOR TO CALL ALBERTA ONE CALL AT 1-800-242-3447 TO HAVE EXISTING UTILITIES LOCATED PRIOR TO START OF ANY CONSTRUCTION.
- THIS DRAWING IS TO BE READ IN CONJUNCTION WITH THE WRITTEN SPECIFICATIONS, DRAWINGS, AND DETAILS FOR THE PROJECT.
- CONTRACTOR TO ENSURE THAT ALL NECESSARY ARRANGEMENTS ARE MADE WITH THE PIPELINE COMPANIES CONCERNING THE MOVEMENT OF MATERIALS AND EQUIPMENT NEAR ANY PIPELINE RIGHTS OF WAY.
- CONTRACTOR IS RESPONSIBLE FOR THE HOARDING OF ALL TREES WITHIN OR ADJACENT TO CONSTRUCTION AREAS.
- CONTRACTOR IS RESPONSIBLE FOR THE ADJUSTMENT OF ALL EXISTING CATCHBASINS, CATCHBASIN MANHOLES, WATER VALVES, HYDRANTS, ETC. TO MATCH PROPOSED GRADES.
- ENSURE POSITIVE DRAINAGE IN ALL SWALES AS SHOWN ON PLAN. DO NOT PERMIT POOLING OF WATER IN DRAINAGE SWALE.
- CONTRACTOR IS RESPONSIBLE FOR HAULING OF ALL EXCESS MATERIALS OFF THE SITE.
- CONTRACTOR IS RESPONSIBLE FOR GENERAL SITE CLEAN UP.
- CONTRACTOR IS RESPONSIBLE FOR ANY DAMAGE TO LANDSCAPED AREAS AND MUST MAKE ALL NECESSARY RESTORATIONS AND REPAIRS.
- ALL ANCILLARY WORK NORMALLY ASSOCIATED WITH THIS TYPE OF CONSTRUCTION SHALL BE DEEMED TO BE PART OF THE CONTRACT.
- ALL QUANTITIES ARE APPROXIMATE ONLY.
- GRADES TO BE APPROVED BY LANDSCAPE ARCHITECT PRIOR TO CONSTRUCTION STARTING.
- CONTRACTOR TO HOLD ROUGH GRADES 450mm BELOW FINISHED GRADE FOR PLANT BEDS, 150mm FOR SEEDED AREAS, 200mm FOR WALKS, 100mm FOR SODDED AREAS.
- STANDARD CONTOUR INTERVAL IS 500mm. SPOT ELEVATIONS AS SHOWN. ALL SPOT ELEVATIONS IN METERS. BERMS AND SLOPES TO BE GRADED SMOOTHLY. ELIMINATE ROUGH SPOTS AND LOW AREAS TO ENSURE POSITIVE DRAINAGE PRIOR TO SEEDING.
- ALL PROPOSED GRADES TO MEET EXISTING GRADES AT PROPERTY LINE WITH A SMOOTH TRANSITION. LIMIT OF GRADING NOT TO EXTEND BEYOND PROPERTY LINE. GRADES TO MEET CURB OR WALK SMOOTHLY. LANDSCAPE ARCHITECT TO APPROVE ROUGH AND FINISHED GRADES.
- MAXIMUM SLOPE OF ANY LANDSCAPED AREA NOT TO EXCEED 33%.
- CONTRACTOR TO TAKE NECESSARY PRECAUTIONS TO PROTECT ALL SITE FEATURES EXISTING AT THE TIME OF CONSTRUCTION UNLESS SPECIFIED FOR DEMOLITION ON THE DRAWING. THIS INCLUDES ALL SURVEY BARS, STAKES OR MONUMENTS. MAKE GOOD ANY DAMAGE.
- ANY AMBIGUITY IN THIS DRAWING OR ACCOMPANYING DETAILS IS TO BE REPORTED TO THE LANDSCAPE ARCHITECT FOR DIRECTION. CONTRACTOR NOT TO PROCEED IN UNCERTAINTY.
- LIMITS OF WORK TO BE CLEARLY UNDERSTOOD BY THE CONTRACTOR PRIOR TO ANY WORK TAKING PLACE ON SITE. CONTRACTOR TO CONTACT LANDSCAPE ARCHITECT FOR CLARIFICATION IF REQUIRED.
- CONTRACTOR TO VISIT SITE TO CONFIRM ALL SITE CONDITIONS PRIOR TO SUBMITTING BIDS. DISCREPANCIES TO BE REPORTED TO LANDSCAPE ARCHITECT FOR CLARIFICATION.
- CONTRACTOR TO VERIFY ALL DIMENSIONS AND REPORT ANY DISCREPANCIES TO THE LANDSCAPE ARCHITECT.
- LAYOUT TO BE APPROVED BY LANDSCAPE ARCHITECT PRIOR TO CONSTRUCTION STARTING.
- ALL MEASUREMENTS ARE IN MILLIMETERS UNLESS OTHERWISE NOTED.
- CONTRACTOR SHALL SUPPLY ALL MATERIALS IN QUANTITIES SUFFICIENT TO COMPLETE WORK SHOWN ON THESE DRAWINGS. ANY DISCREPANCIES SHALL BE REPORTED TO THE LANDSCAPE ARCHITECT FOR DIRECTION.
- NO SUBSTITUTIONS OF MATERIALS, PRODUCTS OR QUANTITIES WITHOUT PRIOR CONSENT OF LANDSCAPE ARCHITECT.



Stantec Consulting Ltd.
10160 - 112 Street
Edmonton AB Canada
Tel. 780.917.7000
www.stantec.com

Copyright Reserved

The Contractor shall verify and be responsible for all dimensions. DO NOT scale the drawing - any errors or omissions shall be reported to Stantec without delay. The Copyrights to all designs and drawings are the property of Stantec. Reproduction or use for any purpose other than that authorized by Stantec is forbidden.

Legend

- MANHOLE
- LIGHT STANDARD
- ⊠ TELEPHONE / VIDEO PEDESTAL
- TRANSFORMER
- HYDRANT

- ▬▬▬▬▬▬ LIMIT OF WORK
- - - - - DEVELOPMENT BOUNDARY
- EDGE OF WATER

Notes

UTILITY SETBACKS

LANDSCAPE CONTRACTOR TO CALL 'ALBERTA ONE-CALL' AT 1-800-242-3447 TO HAVE ALL EXISTING SITE UTILITIES LOCATED PRIOR TO CONSTRUCTION AND PLANT NO CLOSER THAN THE FOLLOWING DIMENSIONS FROM THE SERVICES:

- 1.0m FROM POWER LINES
- 3.5m FROM ALL POWER HARDWARE
- 1.8m FROM WATER MAINS, WATER VALVES, MANUAL AIRVENTS, AND SERVICES
- 2.0m FROM SEWER MAINS, AND MANHOLES
- 1.8m FROM SEWER SERVICES
- 1.5m FROM GAS (NO TREES WITHIN EASEMENT)
- 7.5m FROM STREET CORNERS.
- 3.5m FROM FIRE HYDRANTS.
- 1.5m FROM DRIVEWAYS
- 1.5m FROM ALLEY ACCESSSES
- 1.0m FROM SIDEWALKS OR AS PER APPROVED ENG. CROSS SECTIONS
- 3.5m FROM TRANSIT ZONES
- 3.0m FROM PRIVATE PROPERTY BOUNDARY
- 1.25m FROM COLLECTOR ROAD CURB FACE
- 1.25m FROM LOCAL ROAD CURB FACE
- 2.0m FROM ARTERIAL ROAD CURB FACE
- 3.5m FROM YIELD AND STOP SIGNS
- 3.5m FROM BUS STOP SIGNS
- 2.0m FROM ALL OTHER SIGNS
- 1.0m FROM OTHER UNDERGROUND UTILITIES
- 3.5m FROM TELUS PEDESTALS
- 2.0m FROM TELUS DUCT STRUCTURE
- 1.0m FROM TELUS CABLE FACILITIES

LANDSCAPE CONTRACTOR IS RESPONSIBLE FOR DAMAGES AND LIABILITIES INCURRED BY DAMAGES TO SITE UTILITIES.

Development Engineer, Sustainable Development

Approvals

Revision

1ST ISSUE FOR REVIEW

Issued

File Name: LA_AurumRavine.dwg

Permit-Seal



David A. Price

Client/Project
AURUM INDUSTRIAL
DEVELOPMENT PARTNERSHIP

AURUM ROAD
17 STREET NE TO 9 STREET NE
Edmonton, AB

Title
CREEK AND RAVINE RESTORATION
GRADING AND LAYOUT PLAN

Project No. 1161-104130
Scale 1:500

V:\1161\action\1161-104130\drawing_Landscape\Aurum Road\LA_AurumRavine.dwg
2017-10-10 10:44am BY:KHURJ
Drawing No. L200-001

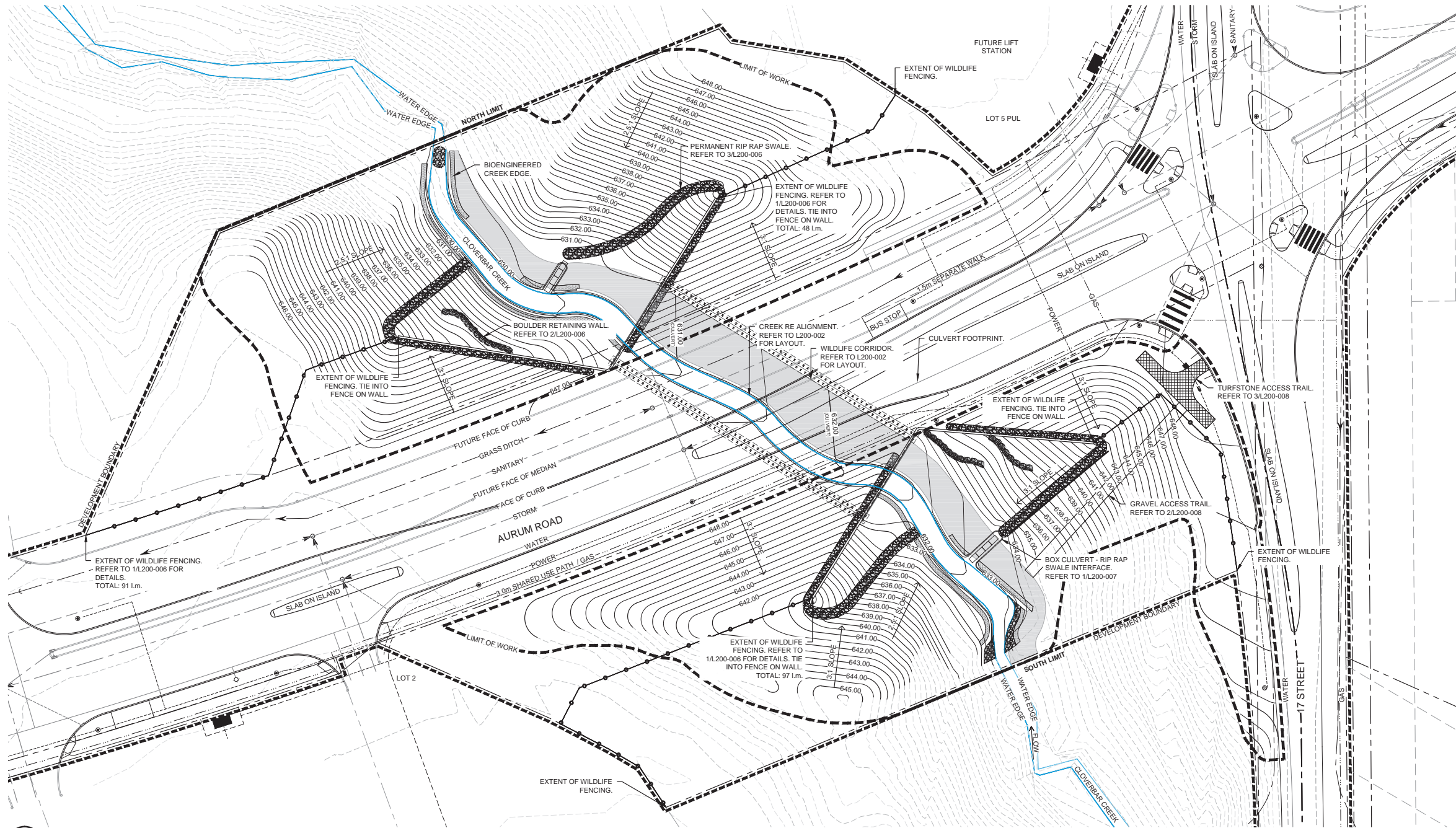

1 GRADING AND LAYOUT PLAN
SCALE: 1:500

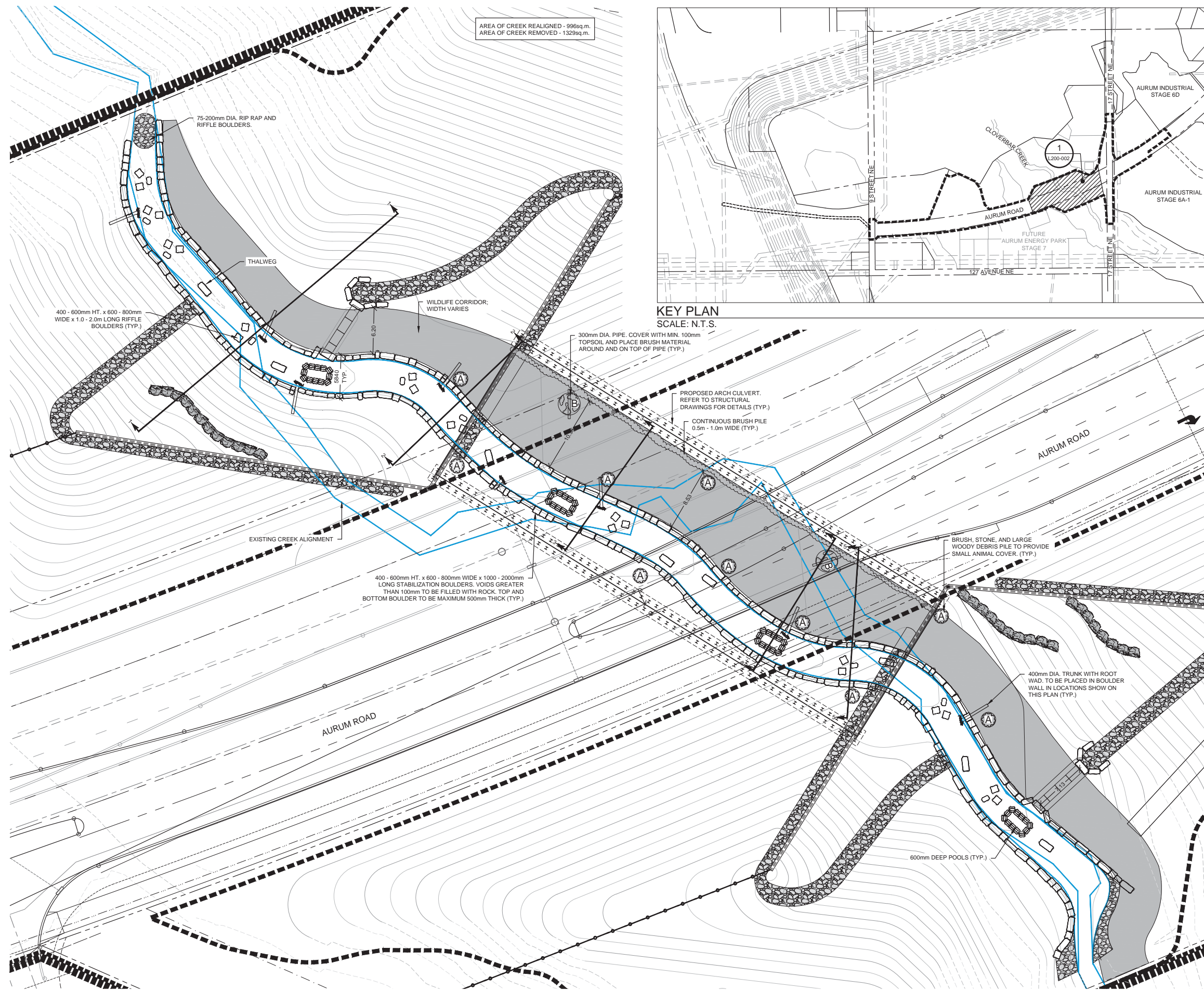

KEY PLAN
SCALE: N.T.S.

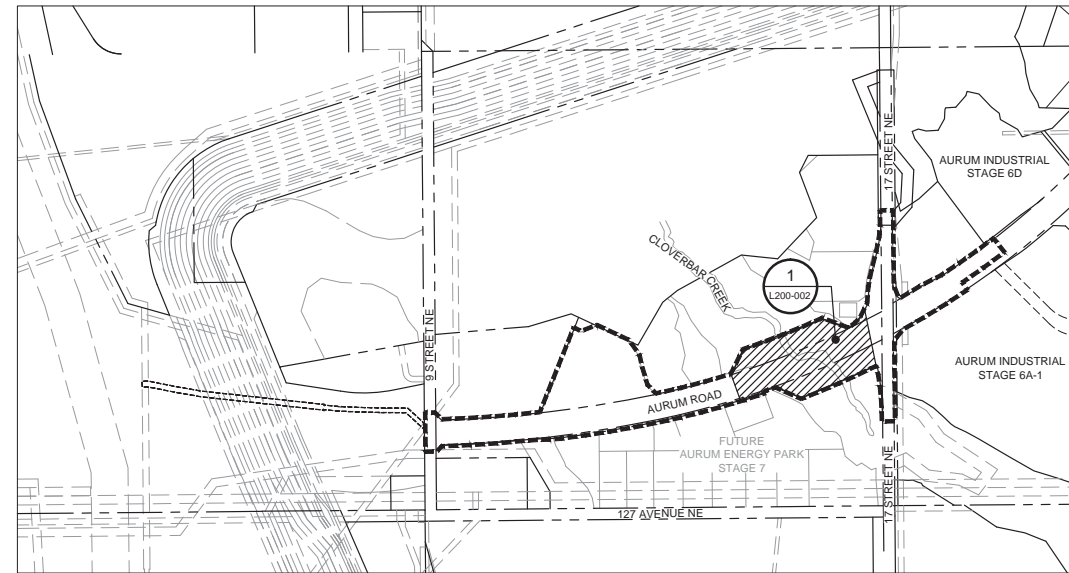

1 CREEK ENLARGMENT GRADING AND LAYOUT
SCALE: 1:250



Stantec Consulting Ltd.
10160 - 112 Street
Edmonton AB Canada
Tel. 780.917.7000
www.stantec.com

Copyright Reserved

The Contractor shall verify and be responsible for all dimensions. DO NOT scale the drawing - any errors or omissions shall be reported to Stantec without delay. The Copyrights to all designs and drawings are the property of Stantec. Reproduction or use for any purpose other than that authorized by Stantec is forbidden.

Legend

- MANHOLE
- LIGHT STANDARD
- TELEPHONE / VIDEO PEDESTAL
- TRANSFORMER
- HYDRANT

Notes

UTILITY SETBACKS

LANDSCAPE CONTRACTOR TO CALL 'ALBERTA ONE-CALL' AT 1-800-242-3447 TO HAVE ALL EXISTING SITE UTILITIES LOCATED PRIOR TO CONSTRUCTION AND PLANT NO CLOSER THAN THE FOLLOWING DIMENSIONS FROM THE SERVICES:

1. 1.0m FROM POWER LINES
2. 3.5m FROM ALL POWER HARDWARE
3. 1.8m FROM WATER MAINS, WATER VALVES, MANUAL AIRVENTS, AND SERVICES
4. 2.0m FROM SEWER MAINS, AND MANHOLES
5. 1.8m FROM SEWER SERVICES
6. 1.5m FROM GAS (NO TREES WITHIN EASEMENT)
7. 7.5m FROM STREET CORNERS.
8. 3.5m FROM FIRE HYDRANTS.
9. 1.5m FROM DRIVEWAYS
10. 1.5m FROM ALLEY ACCESSES
11. 1.0m FROM SIDEWALKS
OR AS PER APPROVED ENG. CROSS SECTIONS
12. 3.5m FROM TRANSIT ZONES
13. 3.0m FROM PRIVATE PROPERTY BOUNDARY
14. 1.25m FROM COLLECTOR ROAD CURB FACE
15. 1.25m FROM LOCAL ROAD CURB FACE
16. 2.0m FROM ARTERIAL ROAD CURB FACE
17. 3.5m FROM YIELD AND STOP SIGNS
18. 3.5m FROM BUS STOP SIGNS
19. 2.0m FROM ALL OTHER SIGNS
20. 1.0m FROM OTHER UNDERGROUND UTILITIES
21. 3.5m FROM TELUS PEDESTALS
22. 2.0m FROM TELUS DUCT STRUCTURE
23. 1.0m FROM TELUS CABLE FACILITIES

LANDSCAPE CONTRACTOR IS RESPONSIBLE FOR DAMAGES AND LIABILITIES INCURRED BY DAMAGES TO SITE UTILITIES.

Development Engineer, Sustainable Development			
Approvals			YY.MM.DD
Revision	By	Appd.	YY.MM.DD
1ST ISSUE FOR REVIEW	KM/KH/CB	DP	17.01.13
Issued	By	Appd.	YY.MM.DD
File Name: LA_AurumRoad_Borenton.dwg	Dwn.	Chkd.	Dsgn.
			YY.MM.DD

Permit-Seal



David A. Price

Client/Project
AURUM INDUSTRIAL DEVELOPMENT PARTNERSHIP
AURUM ROAD
17 STREET NE TO 9 STREET NE
Edmonton, AB

Title
CREEK AND RAVINE RESTORATION
CREEK ENLARGMENT GRADING AND LAYOUT

Project No. 1161-104130 Scale 1:250

V:\1161\Aurum\1161-104130\drawing_Landscape\Aurum Road\LA_AurumRoad_Borenton.dwg 2017-1-19 3:27pm BY:KHURST 2 of 11 Drawing No. L200-002

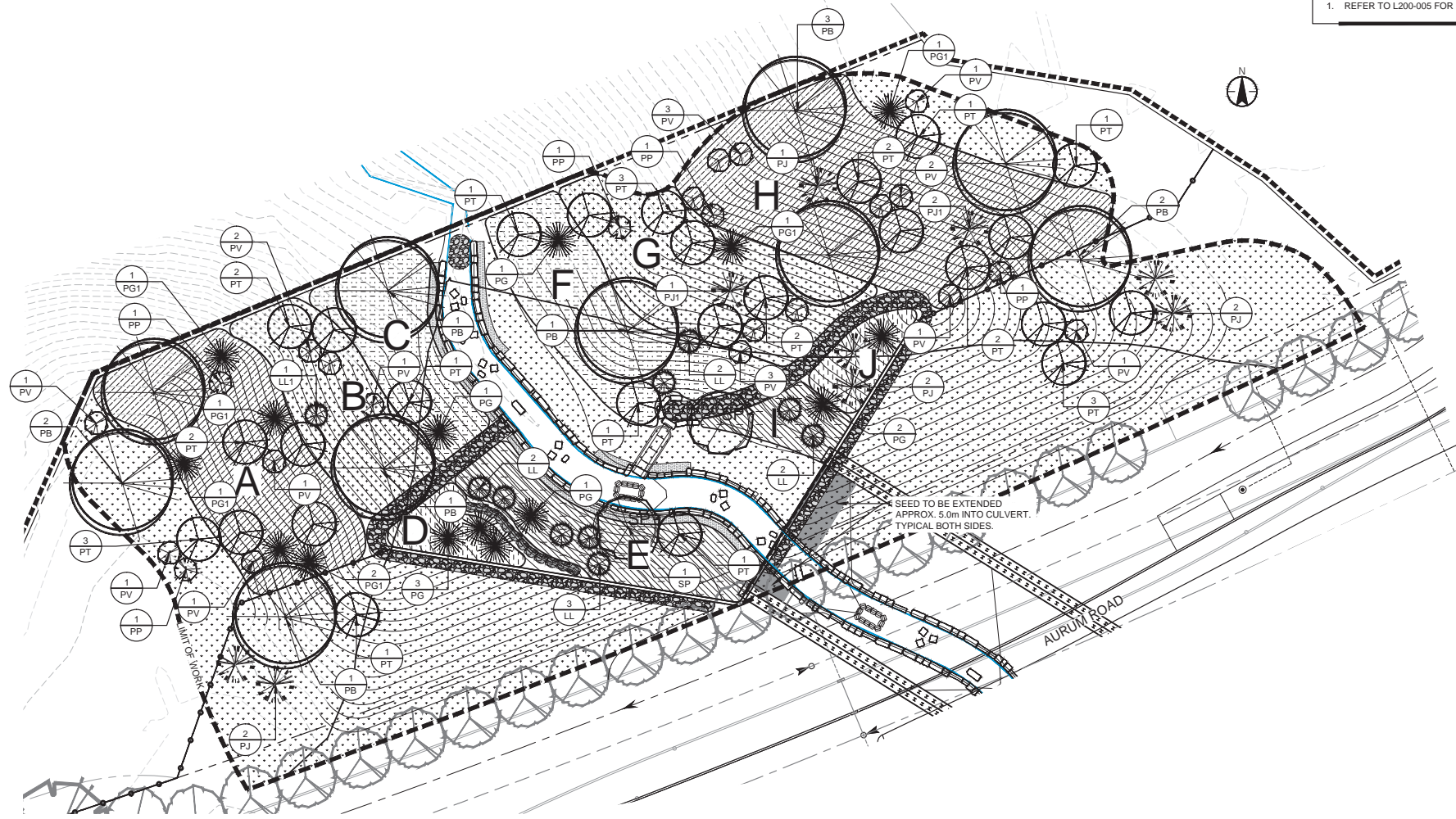

NOTES:
1. REFER TO L200-005 FOR PLANT MATERIAL LIST.

RECLAMATION SEED MIX:
CERTIFIED CANADA NO. 1 MIXTURE, MINIMUM GERMINATION OF 75%, MINIMUM PURITY OF 97%. ALL SEED MUST BE FROM A RECOGNIZED SEED FIRM. MEETING THE REQUIREMENTS FOR THE SEEDS ACT FOR CANADA NO. 1 SEED. SEED SHALL BE CERTIFIED NO. 1 GRADE. A GERMINATION TEST MUST BE REQUESTED AND ALL SEED MUST COMPLY WITH FEDERAL AND PROVINCIAL SEED LAWS.

FOR NON-MAINTAINED NATURALIZATION LANDSCAPING:
10% AWNED (BEARDED) WHEATGRASS
AGROPYRON TRACHYCAULUM
SYN. SUBSECUNDUM
10% WESTERN WHEATGRASS
AGROPYRON SMITHII
10% SLOUGH GRASS
BECKMANNIA SYZYGACHE
10% GIANT WILD RYE
ELYMUS PIPURI SYN. CINEREUS
10% ANNUAL RYEGRASS
LOLIUM MULTIFLORUM
20% TUFTED HAIRGRASS
DESCHAMPSIA CAESPITOSA
30% FOWL BLUEGRASS
POA PALUSTRIS

MULCHMAX 200 HYDROSEED WITH APPLICATION RATE OF 5000kg/ha C/W SEED MIX, TAK300 TACKIFIER & HIGH QUALITY FERTILIZER (18-24-20) OR EQUIVALENT.

NOTES:
1. ENTIRE LIMIT TO RECEIVE 300mm TOPSOIL, NATURALIZATION SEED AND EROSION BLANKET. REFER TO EROSION PLAN FOR DETAILS.

RAVINE PLANTING REQUIREMENTS
THE RAVINE WILL RECEIVE PLANT MATERIAL AS FOLLOWS:
REQUIRED PLANTING = 70 TREES/ha
AREA = 2.3ha x 70 = 161 TREES

PROPOSED PLANTING:
40 UNITS OF 3000mm HT. TREES
121 UNITS OF 40mm CAL./2500mm HT. TREES
1062 UNITS OF #2 CONTAINER PLANT MATERIAL
7092 UNITS OF 1 LITRE PLUGS



Stantec Consulting Ltd.
10160 - 112 Street
Edmonton AB Canada
Tel. 780.917.7000
www.stantec.com

Copyright Reserved

The Contractor shall verify and be responsible for all dimensions. DO NOT scale the drawing - any errors or omissions shall be reported to Stantec without delay. The Copyrights to all designs and drawings are the property of Stantec. Reproduction or use for any purpose other than that authorized by Stantec is forbidden.

Legend

- MANHOLE
- LIGHT STANDARD
- ▣ TELEPHONE / VIDEO PEDESTAL
- TRANSFORMER
- HYDRANT

- LIMIT OF WORK
- DEVELOPMENT BOUNDARY
- EDGE OF WATER

Notes

UTILITY SETBACKS
LANDSCAPE CONTRACTOR TO CALL 'ALBERTA ONE-CALL' AT 1-800-242-3447 TO HAVE ALL EXISTING SITE UTILITIES LOCATED PRIOR TO CONSTRUCTION AND PLANT NO CLOSER THAN THE FOLLOWING DIMENSIONS FROM THE SERVICES:

1. 1.0m FROM POWER LINES
2. 3.5m FROM ALL POWER HARDWARE
3. 1.8m FROM WATER MAINS, WATER VALVES, MANUAL AIRVENTS, AND SERVICES
4. 2.0m FROM SEWER MAINS, AND MANHOLES
5. 1.8m FROM SEWER SERVICES
6. 1.5m FROM GAS (NO TREES WITHIN EASEMENT)
7. 7.5m FROM STREET CORNERS.
8. 3.5m FROM FIRE HYDRANTS.
9. 1.5m FROM DRIVEWAYS
10. 1.5m FROM ALLEY ACCESSES
11. 1.0m FROM SIDEWALKS OR AS PER APPROVED ENG. CROSS SECTIONS
12. 3.5m FROM TRANSIT ZONES
13. 3.0m FROM PRIVATE PROPERTY BOUNDARY
14. 1.25m FROM COLLECTOR ROAD CURB FACE
15. 1.25m FROM LOCAL ROAD CURB FACE
16. 2.0m FROM ARTERIAL ROAD CURB FACE
17. 3.5m FROM YIELD AND STOP SIGNS
18. 3.5m FROM BUS STOP SIGNS
19. 2.0m FROM ALL OTHER SIGNS
20. 1.0m FROM OTHER UNDERGROUND UTILITIES
21. 3.5m FROM TELUS PEDESTALS
22. 2.0m FROM TELUS DUCT STRUCTURE
23. 1.0m FROM TELUS CABLE FACILITIES

LANDSCAPE CONTRACTOR IS RESPONSIBLE FOR DAMAGES AND LIABILITIES INCURRED BY DAMAGES TO SITE UTILITIES.

Development Engineer, Sustainable Development
Approvals _____ YY.MM.DD

Revision _____ By _____ Appd. _____ YY.MM.DD

1ST ISSUE FOR REVIEW _____ KM/KH/CB _____ DP _____ 17.01.13
Issued By _____ Appd. _____ YY.MM.DD

File Name: LA_AurumRavine.dwg
Dwn. _____ Chkd. _____ Dsgn. _____ YY.MM.DD

Permit-Seal



David A. Price

Client/Project
AURUM INDUSTRIAL
DEVELOPMENT PARTNERSHIP
AURUM ROAD
17 STREET NE TO 9 STREET NE
Edmonton, AB

Title
CREEK AND RAVINE RESTORATION
PLANTING PLAN (NORTH)

Project No. 1161-104130
Scale 1:400

V:\1161\action\1161\104130\drawing\landscape\aurum
Road\LA_AurumRavine.dwg
2017-01-11 2:27pm BY:KHURJ
Drawing No. L200-003
3 of 11

1 PLANTING PLAN (NORTH PORTION)
SCALE: 1:400

BED A	
QTY.	BOTANICAL NAME
25	PB1 - Populus balsamifera
37	PT1 - Populus tremuloides
18	PP1 - Prunus pennsylvanica
18	PV1 - Populus virginiana
25	PG2 - Picea glauca
68	aa1 - Amelanchier alnifolia
68	cc1 - Corylus cornuta
102	cs1 - Cornus sericea
136	ra1 - Rosa acicularis
68	so1 - Symphoricarpos occidentalis
102	ve1 - Viburnum edule
136	vt1 - Viburnum trilobum

BED B	
QTY.	BOTANICAL NAME
14	PB1 - Populus balsamifera
21	PT1 - Populus tremuloides
10	PP1 - Prunus pennsylvanica
10	PV1 - Populus virginiana
14	PG2 - Picea glauca
38	aa1 - Amelanchier alnifolia
38	cc1 - Corylus cornuta
57	cs1 - Cornus sericea
76	ra1 - Rosa acicularis
38	so1 - Symphoricarpos occidentalis
57	ve1 - Viburnum edule
76	vt1 - Viburnum trilobum

BED C	
QTY.	BOTANICAL NAME
11	PB1 - Populus balsamifera
17	PT1 - Populus tremuloides
10	PP1 - Prunus pennsylvanica
8	PV1 - Populus virginiana
11	LL2 - Larix laricina
92	cs1 - Cornus sericea
46	ro1 - Ribes oxycanthoides
46	sb1 - Salix bebbiana
61	sd1 - Salix discolor
61	se1 - Salix exigua

BED D	
QTY.	BOTANICAL NAME
4	PB1 - Populus balsamifera
6	PT1 - Populus tremuloides
3	PP1 - Prunus pennsylvanica
3	PV1 - Populus virginiana
4	PG2 - Picea glauca
11	aa - Amelanchier alnifolia
11	cc - Corylus cornuta
17	cs - Cornus sericea
22	ra - Rosa acicularis
11	so - Symphoricarpos occidentalis
17	ve - Viburnum edule
22	vt - Viburnum trilobum

BED E	
QTY.	BOTANICAL NAME
12	PB1 - Populus balsamifera
19	PT1 - Populus tremuloides
9	PP1 - Prunus pennsylvanica
9	PV1 - Populus virginiana
12	LL2 - Larix laricina
103	cs - Cornus sericea
51	ro - Ribes oxycanthoides
51	sb - Salix bebbiana
68	sd - Salix discolor
68	se - Salix exigua

BED F	
QTY.	BOTANICAL NAME
18	PB1 - Populus balsamifera
27	PT1 - Populus tremuloides
13	PP1 - Prunus pennsylvanica
13	PV1 - Populus virginiana
18	LL2 - Larix laricina
147	cs1 - Cornus sericea
73	ro1 - Ribes oxycanthoides
73	sb1 - Salix bebbiana
98	sd1 - Salix discolor
98	se1 - Salix exigua

BED G	
QTY.	BOTANICAL NAME
20	PB1 - Populus balsamifera
30	PT1 - Populus tremuloides
15	PP1 - Prunus pennsylvanica
15	PV1 - Populus virginiana
20	PJ2 - Pinus banksiana
56	aa1 - Amelanchier alnifolia
56	cc1 - Corylus cornuta
84	cs1 - Cornus sericea
112	ra1 - Rosa acicularis
56	so1 - Symphoricarpos occidentalis
84	ve1 - Viburnum edule
112	vt1 - Viburnum trilobum

BED H	
QTY.	BOTANICAL NAME
37	PB1 - Populus balsamifera
56	PT1 - Populus tremuloides
28	PP1 - Prunus pennsylvanica
28	PV1 - Populus virginiana
37	PJ2 - Pinus banksiana
104	aa1 - Amelanchier alnifolia
104	cc1 - Corylus cornuta
155	cs1 - Cornus sericea
207	ra1 - Rosa acicularis
104	so1 - Symphoricarpos occidentalis
155	ve1 - Viburnum edule
207	vt1 - Viburnum trilobum

BED I	
QTY.	BOTANICAL NAME
6	PT1 - Populus tremuloides
3	PP1 - Prunus pennsylvanica
3	PV1 - Populus virginiana
4	LL2 - Larix laricina
31	cs - Cornus sericea
16	ro - Ribes oxycanthoides
16	sb - Salix bebbiana
21	sd - Salix discolor
21	se - Salix exigua

BED J	
QTY.	BOTANICAL NAME
4	PB1 - Populus balsamifera
6	PT1 - Populus tremuloides
3	PP1 - Prunus pennsylvanica
3	PV1 - Populus virginiana
4	PJ2 - Pinus banksiana
11	aa - Amelanchier alnifolia
11	cc - Corylus cornuta
16	cs - Cornus sericea
22	ra - Rosa acicularis
11	so - Symphoricarpos occidentalis
16	ve - Viburnum edule
22	vt - Viburnum trilobum

PLANT BED QUANTITIES
SCALE: N.T.S.

PLANTING NOTES:

1. CONTRACTOR TO CALL ALBERTA ONE CALL AT 1-800-242-3447 TO HAVE EXISTING UTILITIES LOCATED PRIOR TO START OF ANY CONSTRUCTION.
2. CONTRACTOR TO ENSURE THAT ALL NECESSARY ARRANGEMENTS ARE MADE WITH THE PIPELINE COMPANIES CONCERNING THE MOVEMENT OF MATERIALS AND EQUIPMENT NEAR ANY PIPELINE RIGHTS OF WAY.
3. CONTRACTOR IS RESPONSIBLE FOR THE HOARDING OF ALL TREES WITHIN OR ADJACENT TO CONSTRUCTION AREAS.
4. CONTRACTOR IS RESPONSIBLE FOR THE ADJUSTMENT OF ALL EXISTING CATCHBASINS, CATCHBASIN MANHOLES, MANHOLES, WATER VALVES, HYDRANTS, ETC. TO MATCH PROPOSED GRADES.
5. CONTRACTOR TO SUPPLY AND INSTALL 12mm FIBRE MASTIC JOINT WHENEVER MATCHING TO OR ABUTTING TO ANY CONCRETE OR BLOG.
6. CONTRACTOR IS RESPONSIBLE FOR HAULING OF ALL EXCESS MATERIALS OFF THE SITE.
7. CONTRACTOR IS RESPONSIBLE FOR GENERAL SITE CLEAN UP.
8. CONTRACTOR IS RESPONSIBLE FOR ANY DAMAGE TO LANDSCAPED AREAS AND MUST MAKE ALL NECESSARY RESTORATIONS AND REPAIRS.
9. ALL ANCILLARY WORK NORMALLY ASSOCIATED WITH THIS TYPE OF CONSTRUCTION SHALL BE DEEMED TO BE PART OF THE CONTRACT.
10. CONTRACTOR TO VERIFY ALL DIMENSIONS AND REPORT ANY DISCREPANCIES TO THE LANDSCAPE ARCHITECT.
11. LAYOUT TO BE APPROVED BY LANDSCAPE ARCHITECT PRIOR TO CONSTRUCTION STARTING.
12. ALL MEASUREMENTS ARE IN MILLIMETERS UNLESS OTHERWISE NOTED.
13. CONTRACTOR TO OBTAIN APPROVAL FOR PLANT MATERIAL LAYOUT.
14. ALL PLANT MATERIAL TO BE NURSERY GROWN STOCK AND SHALL MEET OR EXCEED THE SPECIFICATIONS OF THE CANADIAN NURSERY TRADES ASSOC. FOR SIZE, HEIGHT, SPREAD, GRADING, QUALITY, AND METHOD OF CULTIVATION.
15. NO SUBSTITUTIONS OF MATERIALS, PRODUCTS OR QUANTITIES WITHOUT PRIOR CONSENT OF LANDSCAPE ARCHITECT.
16. ALL PLANT MATERIAL AND WORKMANSHIP TO CONFORM TO THE REQUIREMENTS OF THE CITY OF EDMONTON DESIGN AND CONSTRUCTION STANDARDS IN ITS MOST RECENT EDITION.

BED K	
QTY.	BOTANICAL NAME
33	PB1 - Populus balsamifera
49	PT1 - Populus tremuloides
25	PP1 - Prunus pennsylvanica
25	PV1 - Populus virginiana
33	PG2 - Picea glauca
91	aa1 - Amelanchier alnifolia
91	cc1 - Corylus cornuta
136	cs1 - Cornus sericea
182	ra1 - Rosa acicularis
91	so1 - Symphoricarpos occidentalis
136	ve1 - Viburnum edule
182	vt1 - Viburnum trilobum

BED L	
QTY.	BOTANICAL NAME
15	PB1 - Populus balsamifera
22	PT1 - Populus tremuloides
11	PP1 - Prunus pennsylvanica
11	PV1 - Populus virginiana
15	PG2 - Picea glauca
41	aa1 - Amelanchier alnifolia
41	cc1 - Corylus cornuta
62	cs1 - Cornus sericea
82	ra1 - Rosa acicularis
41	so1 - Symphoricarpos occidentalis
62	ve1 - Viburnum edule
82	vt1 - Viburnum trilobum

BED M	
QTY.	BOTANICAL NAME
9	PB1 - Populus balsamifera
13	PT1 - Populus tremuloides
7	PP1 - Prunus pennsylvanica
7	PV1 - Populus virginiana
9	LL2 - Larix laricina
74	cs1 - Cornus sericea
37	ro1 - Ribes oxycanthoides
37	sb1 - Salix bebbiana
49	sd1 - Salix discolor
9	so - Symphoricarpos occidentalis
14	ve - Viburnum edule
19	vt - Viburnum trilobum

BED N	
QTY.	BOTANICAL NAME
3	PB1 - Populus balsamifera
5	PT1 - Populus tremuloides
3	PP1 - Prunus pennsylvanica
3	PV1 - Populus virginiana
3	PG2 - Picea glauca
9	aa - Amelanchier alnifolia
9	cc - Corylus cornuta
14	cs - Cornus sericea
19	ra - Rosa acicularis
9	so - Symphoricarpos occidentalis
14	ve - Viburnum edule
19	vt - Viburnum trilobum

BED O	
QTY.	BOTANICAL NAME
4	PB1 - Populus balsamifera
6	PT1 - Populus tremuloides
3	PP1 - Prunus pennsylvanica
3	PV1 - Populus virginiana
4	LL2 - Larix laricina
33	cs - Cornus sericea
16	ro - Ribes oxycanthoides
16	sb - Salix bebbiana
22	sd - Salix discolor
22	se - Salix exigua

BED P	
QTY.	BOTANICAL NAME
5	PB1 - Populus balsamifera
8	PT1 - Populus tremuloides
4	PP1 - Prunus pennsylvanica
4	PV1 - Populus virginiana
5	LL2 - Larix laricina
42	cs1 - Cornus sericea
21	ro1 - Ribes oxycanthoides
21	sb1 - Salix bebbiana
28	sd1 - Salix discolor
28	se1 - Salix exigua

BED Q	
QTY.	BOTANICAL NAME
3	PB1 - Populus balsamifera
4	PT1 - Populus tremuloides
2	PP1 - Prunus pennsylvanica
2	PV1 - Populus virginiana
3	PJ2 - Pinus banksiana
8	aa - Amelanchier alnifolia
8	cc - Corylus cornuta
11	cs - Cornus sericea
15	ra - Rosa acicularis
8	so - Symphoricarpos occidentalis
11	ve - Viburnum edule
15	vt - Viburnum trilobum

BED R	
QTY.	BOTANICAL NAME
4	PB1 - Populus balsamifera
6	PT1 - Populus tremuloides
3	PP1 - Prunus pennsylvanica
3	PV1 - Populus virginiana
4	PJ2 - Pinus banksiana
12	aa - Amelanchier alnifolia
12	cc - Corylus cornuta
18	cs - Cornus sericea
23	ra - Rosa acicularis
12	so - Symphoricarpos occidentalis
18	ve - Viburnum edule
23	vt - Viburnum trilobum

BED S	
QTY.	BOTANICAL NAME
1	PB1 - Populus balsamifera
2	PT1 - Populus tremuloides
1	PP1 - Prunus pennsylvanica
1	PV1 - Populus virginiana
1	LL2 - Larix laricina
9	cs1 - Cornus sericea
5	ro1 - Ribes oxycanthoides
5	sb1 - Salix bebbiana
6	sd1 - Salix discolor
6	se1 - Salix exigua

BED T	
QTY.	BOTANICAL NAME
2	PB1 - Populus balsamifera
4	PT1 - Populus tremuloides
2	PP1 - Prunus pennsylvanica
2	PV1 - Populus virginiana
2	PJ2 - Pinus banksiana
7	aa1 - Amelanchier alnifolia
7	cc1 - Corylus cornuta
10	cs1 - Cornus sericea
13	ra1 - Rosa acicularis
7	so1 - Symphoricarpos occidentalis
10	ve1 - Viburnum edule
13	vt1 - Viburnum trilobum

BED U	
QTY.	BOTANICAL NAME
2	PB1 - Populus balsamifera
3	PT1 - Populus tremuloides
2	PP1 - Prunus pennsylvanica
2	PV1 - Populus virginiana
2	PJ2 - Pinus banksiana
18	cs1 - Cornus sericea
9	ro1 - Ribes oxycanthoides
9	sb1 - Salix bebbiana
12	sd1 - Salix discolor
12	se1 - Salix exigua

BED V	
QTY.	BOTANICAL NAME
5	PB1 - Populus balsamifera
7	PT1 - Populus tremuloides
3	PP1 - Prunus pennsylvanica
3	PV1 - Populus virginiana
5	PJ2 - Pinus banksiana
13	aa1 - Amelanchier alnifolia
12	cc1 - Corylus cornuta
19	cs1 - Cornus sericea
26	ra1 - Rosa acicularis
13	so1 - Symphoricarpos occidentalis
19	ve1 - Viburnum edule
26	vt1 - Viburnum trilobum

BED W	
QTY.	BOTANICAL NAME
4	PB1 - Populus balsamifera
6	PT1 - Populus tremuloides
3	PP1 - Prunus pennsylvanica
3	PV1 - Populus virginiana
4	PJ2 - Pinus banksiana
12	aa1 - Amelanchier alnifolia
12	cc1 - Corylus cornuta
18	cs1 - Cornus sericea
23	ra1 - Rosa acicularis
12	so1 - Symphoricarpos occidentalis
18	ve1 - Viburnum edule
23	vt1 - Viburnum trilobum

BED X	
QTY.	BOTANICAL NAME
3	PB1 - Populus balsamifera
5	PT1 - Populus tremuloides
2	PP1 - Prunus pennsylvanica
2	PV1 - Populus virginiana
3	LL2 - Larix laricina
27	cs1 - Cornus sericea
13	ro1 - Ribes oxycanthoides
13	sb1 - Salix bebbiana
18	sd1 - Salix discolor
18	se1 - Salix exigua

BED Y	
QTY.	BOTANICAL NAME
5	PB1 - Populus balsamifera
8	PT1 - Populus tremuloides
4	PP1 - Prunus pennsylvanica
4	PV1 - Populus virginiana
5	PJ2 - Pinus banksiana
14	aa1 - Amelanchier alnifolia
14	cc1 - Corylus cornuta
21	cs1 - Cornus sericea
28	ra1 - Rosa acicularis
14	so1 - Symphoricarpos occidentalis
21	ve1 - Viburnum edule
28	vt1 - Viburnum trilobum

BED Z	
QTY.	BOTANICAL NAME
9	PB1 - Populus balsamifera
13	PT1 - Populus tremuloides
7	PP1 - Prunus pennsylvanica
7	PV1 - Populus virginiana
9	PJ2 - Pinus banksiana
24	aa1 - Amelanchier alnifolia
24	cc1 - Corylus cornuta
37	cs1 - Cornus sericea
49	ra1 - Rosa acicularis
24	so1 - Symphoricarpos occidentalis
37	ve1 - Viburnum edule
49	vt1 - Viburnum trilobum

NOTES:
1. REFER TO L200-005 FOR PLANT MATERIAL LIST.

PLANT BED QUANTITIES
SCALE: N.T.S.

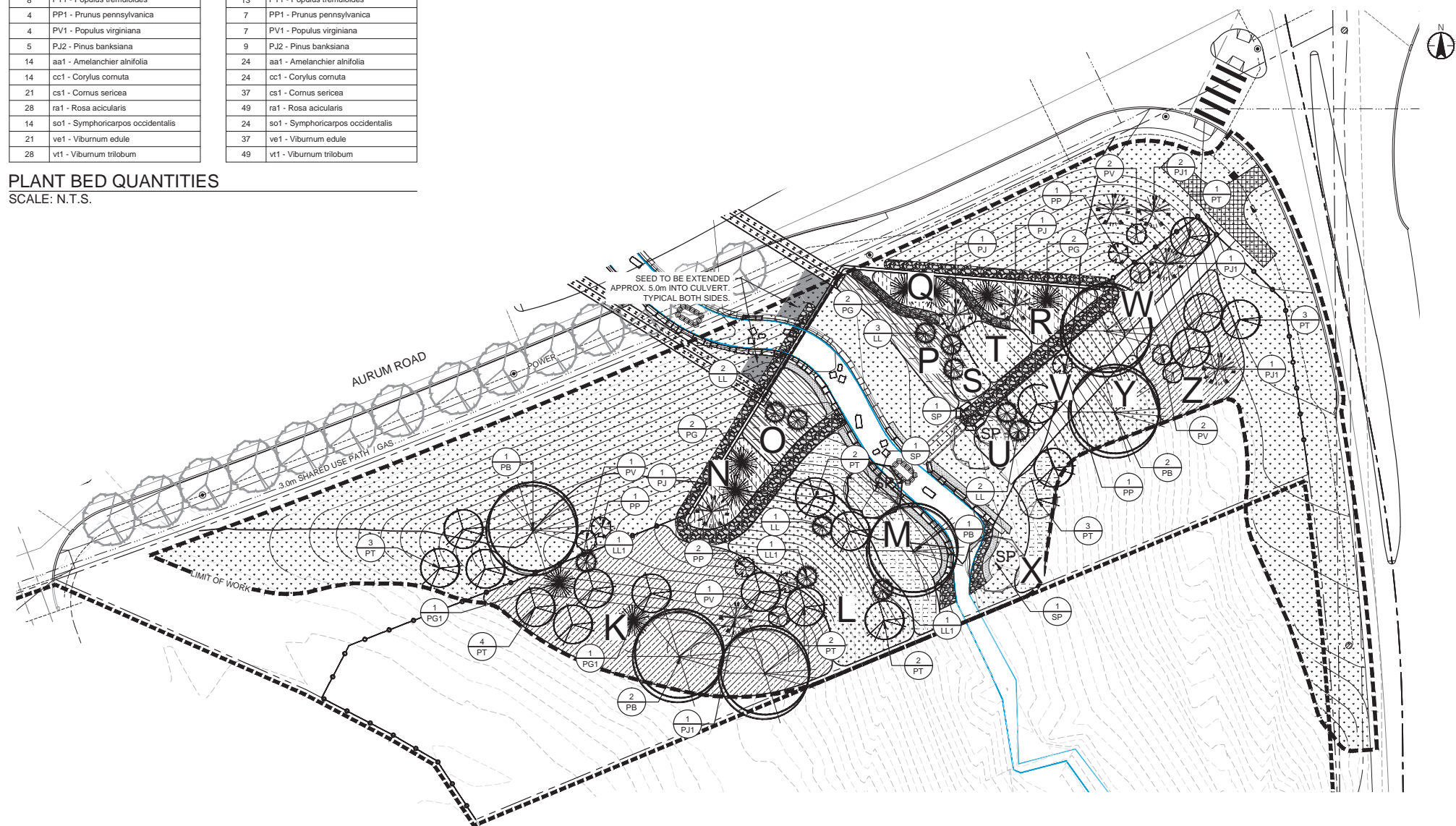

1 PLANTING PLAN (SOUTH PORTION)
SCALE: 1:400



Stantec Consulting Ltd.
10160 - 112 Street
Edmonton AB Canada
Tel. 780.917.7000
www.stantec.com

Copyright Reserved
The Contractor shall verify and be responsible for all dimensions, DO NOT scale the drawing - any errors or omissions shall be reported to Stantec without delay. The Copyrights to all designs and drawings are the property of Stantec. Reproduction or use for any purpose other than that authorized by Stantec is forbidden.

- Legend**
- MANHOLE
 - LIGHT STANDARD
 - ☒ TELEPHONE / VIDEO PEDESTAL
 - TRANSFORMER
 - HYDRANT
 - LIMIT OF WORK
 - DEVELOPMENT BOUNDARY
 - EDGE OF WATER

- Notes**
UTILITY SETBACKS
LANDSCAPE CONTRACTOR TO CALL 'ALBERTA ONE-CALL' AT 1-800-242-3447 TO HAVE ALL EXISTING SITE UTILITIES LOCATED PRIOR TO CONSTRUCTION AND PLANT NO CLOSER THAN THE FOLLOWING DIMENSIONS FROM THE SERVICES:

1. 1.0m FROM POWER LINES
2. 3.5m FROM ALL POWER HARDWARE
3. 1.8m FROM WATER MAINS, WATER VALVES, MANUAL AIRVENTS, AND SERVICES
4. 2.0m FROM SEWER MAINS, AND MANHOLES
5. 1.8m FROM SEWER SERVICES
6. 1.5m FROM GAS (NO TREES WITHIN EASEMENT)
7. 7.5m FROM STREET CORNERS.
8. 3.5m FROM FIRE HYDRANTS.
9. 1.5m FROM DRIVEWAYS
10. 1.5m FROM ALLEY ACCESSES
11. 1.0m FROM SIDEWALKS OR AS PER APPROVED ENG. CROSS SECTIONS
12. 3.5m FROM TRANSIT ZONES
13. 3.0m FROM PRIVATE PROPERTY BOUNDARY
14. 1.25m FROM COLLECTOR ROAD CURB FACE
15. 1.25m FROM LOCAL ROAD CURB FACE
16. 2.0m FROM ARTERIAL ROAD CURB FACE
17. 3.5m FROM YIELD AND STOP SIGNS
18. 3.5m FROM BUS STOP SIGNS
19. 2.0m FROM ALL OTHER SIGNS
20. 1.0m FROM OTHER UNDERGROUND UTILITIES
21. 3.5m FROM TELUS PEDESTALS
22. 2.0m FROM TELUS DUCT STRUCTURE
23. 1.0m FROM TELUS CABLE FACILITIES

LANDSCAPE CONTRACTOR IS RESPONSIBLE FOR DAMAGES AND LIABILITIES INCURRED BY DAMAGES TO SITE UTILITIES.

Development Engineer, Sustainable Development			
Approvals			YY.MM.DD
Revision		By	Appd. YY.MM.DD
1ST ISSUE FOR REVIEW		By	Appd. YY.MM.DD
Issued		By	Appd. YY.MM.DD
File Name: LA_AurumRavine.dwg		Dwn.	Chkd. Dsgn. YY.MM.DD

Permit-Seal



David A. Price
Client/Project
AURUM INDUSTRIAL DEVELOPMENT PARTNERSHIP
AURUM ROAD
17 STREET NE TO 9 STREET NE
Edmonton, AB

Title
CREEK AND RAVINE RESTORATION PLANTING PLAN (SOUTH)

Project No. 1161-104130
Scale 1:400

PLANT MATERIAL LIST: (THIS SHEET ONLY)

QTY./SYM.	BOTANICAL/COMMON NAME	SIZE	CONDITION
DECIDUOUS TREES			
16 PB	<i>Populus balsamifera</i> BALSAM POPLAR	40 mm CAL.	OVERALL HEIGHT TO BE 2500-3000mm WITH MIN. 8 BRANCHES. WIRE BASKET, BALLED & BURLAPPED. MIN. 600mm ROOT BALL DIA. WITH DEPTH NOT LESS THAN 400mm.
256 PBT	<i>Populus balsamifera</i> BALSAM POPLAR	1 LITRE PLUG	300-450mm WHIPS TO HAVE STRAIGHT, STURDY TRUNKS AND A WELL DEVELOPED ROOT SYSTEM.
44 PT	<i>Populus tremuloides</i> TREMBLING ASPEN	40 mm CAL.	OVERALL HEIGHT TO BE 2500-3000mm WITH MIN. 8 BRANCHES. WIRE BASKET, BALLED & BURLAPPED. MIN. 600mm ROOT BALL DIA. WITH DEPTH NOT LESS THAN 400mm.
386 PT1	<i>Populus tremuloides</i> TREMBLING ASPEN	1 LITRE PLUG	300-450mm WHIPS TO HAVE STRAIGHT, STURDY TRUNKS AND A WELL DEVELOPED ROOT SYSTEM.
13 PP	<i>Prunus pennsylvanica</i> PIN CHERRY	40 mm CAL.	OVERALL HEIGHT TO BE 2500-3000mm WITH MIN. 8 BRANCHES. WIRE BASKET, BALLED & BURLAPPED. MIN. 600mm ROOT BALL DIA. WITH DEPTH NOT LESS THAN 400mm.
192 PP1	<i>Prunus pennsylvanica</i> PIN CHERRY	1 LITRE PLUG	300-450mm WHIPS TO HAVE STRAIGHT, STURDY TRUNKS AND A WELL DEVELOPED ROOT SYSTEM.
26 PV	<i>Prunus virginiana</i> COMMON CHOKECHERRY	40 mm CAL.	OVERALL HEIGHT TO BE 2500-3000mm WITH MIN. 8 BRANCHES. WIRE BASKET, BALLED & BURLAPPED. MIN. 600mm ROOT BALL DIA. WITH DEPTH NOT LESS THAN 400mm.
192 PV1	<i>Prunus virginiana</i> COMMON CHOKECHERRY	1 LITRE PLUG	300-450mm WHIPS TO HAVE STRAIGHT, STURDY TRUNKS AND A WELL DEVELOPED ROOT SYSTEM.
5 SP	<i>Salix pentandra</i> LAUREL LEAF WILLOW	40mm CAL.	OVERALL HEIGHT TO BE 2500-3000mm WITH MIN. 8 BRANCHES. WIRE BASKET, BALLED & BURLAPPED. MIN. 600mm ROOT BALL DIA. WITH DEPTH NOT LESS THAN 400mm.
CONIFEROUS TREES			
18 LL	<i>Larix laricina</i> TAMARACK LARCH	3000 mm HT.	WIDTH AT BASE MIN. 40% OF HT. WIRE BASKET, BALLED & BURLAPPED MIN. ROOT BALL DIA. 1220mm.
4 LL1	<i>Larix laricina</i> TAMARACK LARCH	2500 mm HT.	WIDTH AT BASE MIN. 40% OF HT. WIRE BASKET, BALLED & BURLAPPED MIN. ROOT BALL DIA. 900mm.
69 LL2	<i>Larix laricina</i> TAMARACK LARCH	1 LITRE PLUG	300-450mm WHIPS TO HAVE STRAIGHT, STURDY TRUNKS AND A WELL DEVELOPED ROOT SYSTEM.
13 PG	<i>Picea glauca</i> WHITE SPRUCE	3000 mm HT.	WIDTH AT BASE MIN. 40% OF HT. WIRE BASKET, BALLED & BURLAPPED MIN. ROOT BALL DIA. 1220mm.
10 PG1	<i>Picea glauca</i> WHITE SPRUCE	2500 mm HT.	WIDTH AT BASE MIN. 40% OF HT. WIRE BASKET, BALLED & BURLAPPED MIN. ROOT BALL DIA. 900mm.
94 PG2	<i>Picea glauca</i> WHITE SPRUCE	1 LITRE PLUG	300-450mm WHIPS TO HAVE STRAIGHT, STURDY TRUNKS AND A WELL DEVELOPED ROOT SYSTEM.
9 PJ	<i>Pinus banksiana</i> JACK PINE	3000 mm HT.	WIDTH AT BASE MIN. 40% OF HT. WIRE BASKET, BALLED & BURLAPPED MIN. ROOT BALL DIA. 1220mm.
8 PJ1	<i>Pinus banksiana</i> JACK PINE	2500 mm HT.	WIDTH AT BASE MIN. 40% OF HT. WIRE BASKET, BALLED & BURLAPPED MIN. ROOT BALL DIA. 900mm.
93 PJ2	<i>Pinus banksiana</i> JACK PINE	1 LITRE PLUG	300-450mm WHIPS TO HAVE STRAIGHT, STURDY TRUNKS AND A WELL DEVELOPED ROOT SYSTEM.

PLANT MATERIAL LIST: (THIS SHEET ONLY)

BOTANICAL/COMMON NAME	SIZE	CONDITION
DECIDUOUS SHRUBS		
51 aa	<i>Amelanchier alnifolia</i> SASKATOON	300 mm HT. MIN. #2 CONTAINER CONTAINER GROWN, OR BALLED & BURLAPPED 4 CANES OR MORE 300mm HT. WITH MIN ROOT SPREAD 200mm.
468 aa1	<i>Amelanchier alnifolia</i> SASKATOON	1 LITRE PLUG 300-450mm WHIPS TO HAVE STRAIGHT, STURDY TRUNKS AND A WELL DEVELOPED ROOT SYSTEM.
243 cs	<i>Cornus sericea</i> RED OSIER DOGWOOD	300 mm HT. MIN. #2 CONTAINER CONTAINER GROWN, OR BALLED & BURLAPPED 4 CANES OR MORE 300mm HT. WITH MIN ROOT SPREAD 200mm.
1110 cs1	<i>Cornus sericea</i> RED OSIER DOGWOOD	1 LITRE PLUG 300-450mm WHIPS TO HAVE STRAIGHT, STURDY TRUNKS AND A WELL DEVELOPED ROOT SYSTEM.
51 cc	<i>Corylus cornuta</i> BEAKED HAZELNUT	300 mm HT. MIN. #2 CONTAINER CONTAINER GROWN, OR BALLED & BURLAPPED 4 CANES OR MORE 300mm HT. WITH MIN ROOT SPREAD 200mm.
468 cc1	<i>Corylus cornuta</i> BEAKED HAZELNUT	1 LITRE PLUG 300-450mm WHIPS TO HAVE STRAIGHT, STURDY TRUNKS AND A WELL DEVELOPED ROOT SYSTEM.
83 to	<i>Ribes oxycanthoides</i> NORTHERN GOOSEBERRY	300 mm HT. MIN. #2 CONTAINER CONTAINER GROWN, OR BALLED & BURLAPPED 4 CANES OR MORE 300mm HT. WITH MIN ROOT SPREAD 200mm.
204 ro1	<i>Ribes oxycanthoides</i> NORTHERN GOOSEBERRY	1 LITRE PLUG 300-450mm WHIPS TO HAVE STRAIGHT, STURDY TRUNKS AND A WELL DEVELOPED ROOT SYSTEM.
101 ra	<i>Rosa acicularis</i> PRICKLY ROSE	300 mm HT. MIN. #2 CONTAINER CONTAINER GROWN, OR BALLED & BURLAPPED 4 CANES OR MORE 300mm HT. WITH MIN ROOT SPREAD 200mm.
934 ra1	<i>Rosa acicularis</i> PRICKLY ROSE	1 LITRE PLUG 300-450mm WHIPS TO HAVE STRAIGHT, STURDY TRUNKS AND A WELL DEVELOPED ROOT SYSTEM.
83 sb	<i>Salix bebbiana</i> BEBB'S WILLOW	300 mm HT. MIN. #2 CONTAINER CONTAINER GROWN, OR BALLED & BURLAPPED 4 CANES OR MORE 300mm HT. WITH MIN ROOT SPREAD 200mm.
204 sb1	<i>Salix bebbiana</i> BEBB'S WILLOW	1 LITRE PLUG 300-450mm WHIPS TO HAVE STRAIGHT, STURDY TRUNKS AND A WELL DEVELOPED ROOT SYSTEM.
111 sd	<i>Salix discolor</i> PUSSY WILLOW	300 mm HT. MIN. #2 CONTAINER CONTAINER GROWN, OR BALLED & BURLAPPED 4 CANES OR MORE 300mm HT. WITH MIN ROOT SPREAD 200mm.
267 sd1	<i>Salix discolor</i> PUSSY WILLOW	1 LITRE PLUG 300-450mm WHIPS TO HAVE STRAIGHT, STURDY TRUNKS AND A WELL DEVELOPED ROOT SYSTEM.
111 se	<i>Salix exigua</i> COYOTE WILLOW	300 mm HT. MIN. #2 CONTAINER CONTAINER GROWN, OR BALLED & BURLAPPED 4 CANES OR MORE 300mm HT. WITH MIN ROOT SPREAD 200mm.
272 se1	<i>Salix exigua</i> COYOTE WILLOW	1 LITRE PLUG 300-450mm WHIPS TO HAVE STRAIGHT, STURDY TRUNKS AND A WELL DEVELOPED ROOT SYSTEM.
51 so	<i>Symphoricarpos occidentalis</i> WESTERN SNOWBERRY	300 mm HT. MIN. #2 CONTAINER CONTAINER GROWN, OR BALLED & BURLAPPED 4 CANES OR MORE 300mm HT. WITH MIN ROOT SPREAD 200mm.
468 so1	<i>Symphoricarpos occidentalis</i> WESTERN SNOWBERRY	1 LITRE PLUG 300-450mm WHIPS TO HAVE STRAIGHT, STURDY TRUNKS AND A WELL DEVELOPED ROOT SYSTEM.
76 ve	<i>Viburnum edule</i> LOWBUSH CRANBERRY	300 mm HT. MIN. #2 CONTAINER CONTAINER GROWN, OR BALLED & BURLAPPED 4 CANES OR MORE 300mm HT. WITH MIN ROOT SPREAD 200mm.
701 vb1	<i>Viburnum edule</i> LOWBUSH CRANBERRY	1 LITRE PLUG 300-450mm WHIPS TO HAVE STRAIGHT, STURDY TRUNKS AND A WELL DEVELOPED ROOT SYSTEM.
101 vt	<i>Viburnum trilobum</i> HIGHBUSH CRANBERRY	300 mm HT. MIN. #2 CONTAINER CONTAINER GROWN, OR BALLED & BURLAPPED 4 CANES OR MORE 300mm HT. WITH MIN ROOT SPREAD 200mm.
934 vt1	<i>Viburnum trilobum</i> HIGHBUSH CRANBERRY	1 LITRE PLUG 300-450mm WHIPS TO HAVE STRAIGHT, STURDY TRUNKS AND A WELL DEVELOPED ROOT SYSTEM.

NOTE: ALL TREES TO BE HIGH HEADED AND EXHIBIT A FULL AND UNIFORM CROWN, WITH A SINGLE, DOMINANT, WELL DEVELOPED LEADER; TREES WITH BROKEN OR DAMAGED OR MISSING LEADERS WILL NOT BE ACCEPTED. ALL PLANT MATERIAL MUST CONFORM TO THE CITY OF EDMONTON DESIGN AND CONSTRUCTION STANDARDS.



Stantec Consulting Ltd.
10160 - 112 Street
Edmonton AB Canada
Tel. 780.917.7000
www.stantec.com

Copyright Reserved

The Contractor shall verify and be responsible for all dimensions. DO NOT scale the drawing - any errors or omissions shall be reported to Stantec without delay. The Copyrights to all designs and drawings are the property of Stantec. Reproduction or use for any purpose other than that authorized by Stantec is forbidden.

Legend

Notes

UTILITY SETBACKS

LANDSCAPE CONTRACTOR TO CALL 'ALBERTA ONE-CALL' AT 1-800-242-3447 TO HAVE ALL EXISTING SITE UTILITIES LOCATED PRIOR TO CONSTRUCTION AND PLANT NO CLOSER THAN THE FOLLOWING DIMENSIONS FROM THE SERVICES:

- 1.0m FROM POWER LINES
- 3.5m FROM ALL POWER HARDWARE
- 1.8m FROM WATER MAINS, WATER VALVES, MANUAL AIRVENTS, AND SERVICES
- 2.0m FROM SEWER MAINS, AND MANHOLES
- 1.8m FROM SEWER SERVICES
- 1.5m FROM GAS (NO TREES WITHIN EASEMENT)
- 7.5m FROM STREET CORNERS.
- 3.5m FROM FIRE HYDRANTS.
- 1.5m FROM DRIVEWAYS
- 1.5m FROM ALLEY ACCESSES
- 1.0m FROM SIDEWALKS OR AS PER APPROVED ENG. CROSS SECTIONS
- 3.5m FROM TRANSIT ZONES
- 3.0m FROM PRIVATE PROPERTY BOUNDARY
- 1.25m FROM COLLECTOR ROAD CURB FACE
- 1.25m FROM LOCAL ROAD CURB FACE
- 2.0m FROM ARTERIAL ROAD CURB FACE
- 3.5m FROM YIELD AND STOP SIGNS
- 3.5m FROM BUS STOP SIGNS
- 2.0m FROM ALL OTHER SIGNS
- 1.0m FROM OTHER UNDERGROUND UTILITIES
- 3.5m FROM TELUS PEDESTALS
- 2.0m FROM TELUS DUCT STRUCTURE
- 1.0m FROM TELUS CABLE FACILITIES

LANDSCAPE CONTRACTOR IS RESPONSIBLE FOR DAMAGES AND LIABILITIES INCURRED BY DAMAGES TO SITE UTILITIES.

Development Engineer, Sustainable Development			
Approvals			YY.MM.DD
Revision	By	Appd.	YY.MM.DD
1ST ISSUE FOR REVIEW	KM/KH/CB	DP	17.01.13
Issued	By	Appd.	YY.MM.DD
File Name: LA_AurumRavine.dwg	Dwn.	Chkd.	Dsgn.
			YY.MM.DD

Permit-Seal



David A. Price

Client/Project

AURUM INDUSTRIAL
DEVELOPMENT PARTNERSHIP

AURUM ROAD
17 STREET NE TO 9 STREET NE
Edmonton, AB

Title

CREEK AND RAVINE RESTORATION
PLANT MATERIAL LIST

Project No.
1161-104130

Scale
AS SHOWN

V:\1161\Aurum\1161-104130\drawing_Landscape\Aurum
Road\LA_AurumRavine.dwg

2017-1-20 11:19am BY:KHURST

5 of 11

Drawing No.

L200-005

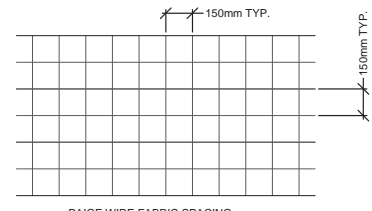
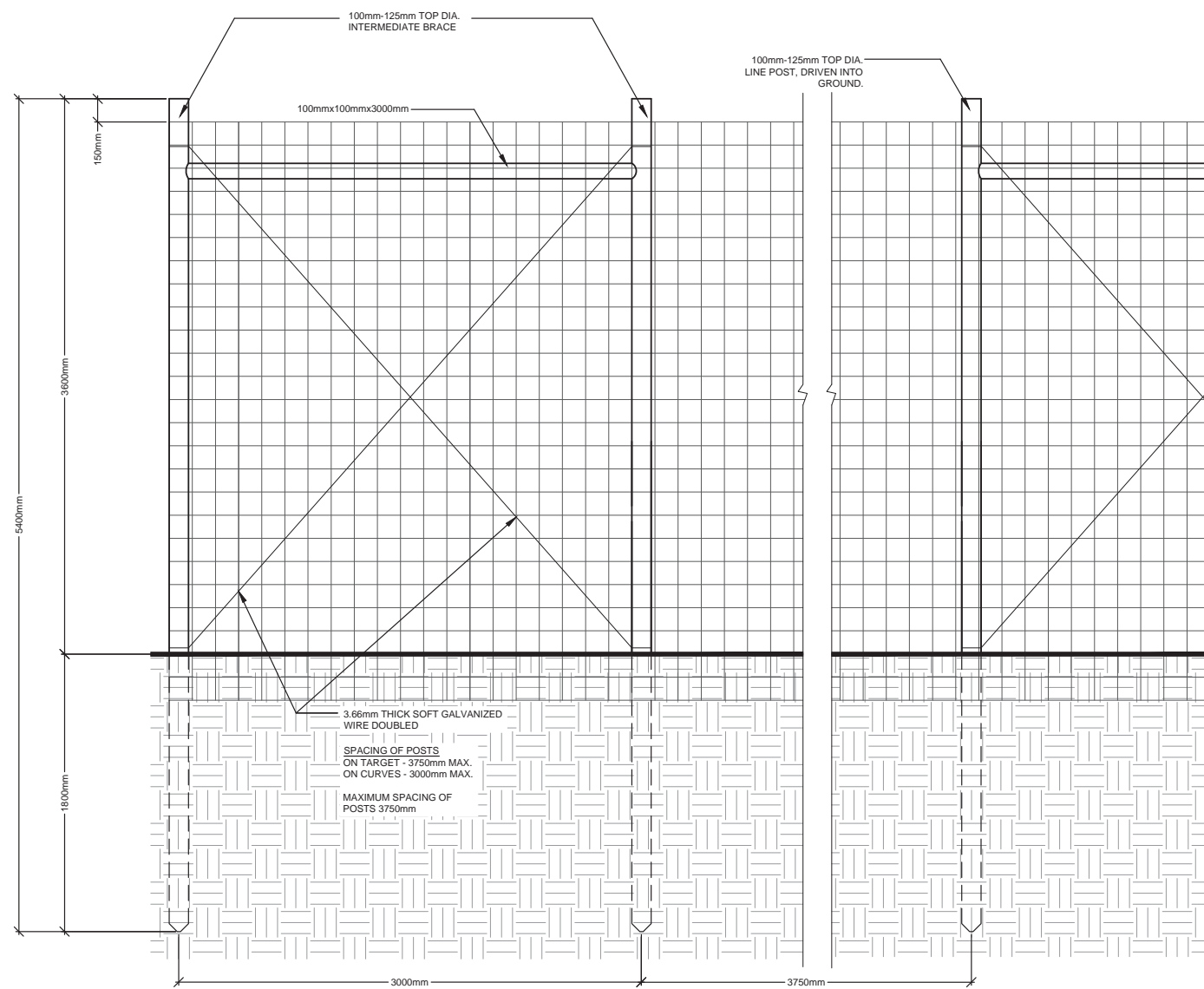

PAGE WIRE FENCE NOTES:

1. ALL FENCE POSTS SHALL BE PRESSURE TREATED TIMBER.
2. ALLOWABLE TAPER FROM END TO END OF POST SHALL NOT EXCEED 38mm IN DIAMETER. POSTS SHALL BE INSTALLED WITH THE LARGE END DOWN.
3. PAIGE WIRE FENCE WIRES TO BE SPACED AS SHOWN WITH 3.66mm THICK GALVANIZED WIRE USED THROUGHOUT.
4. ADJACENT ROLLS OF PAIGE WIRE TO BE JOINED AT POST LOCATION.
5. LINE AND STAY WIRES TO BE JOINED THROUGHOUT WITH TIGHT LOCK KNOT CONSTRUCTION.
6. NOMINAL DIMENSIONS FOR PAIGE WIRE SHOWN.
7. 40mm STAPLES TO BE SPACED 152mm INTERVALS SO THAT EACH LINE WIRE IS FIRMLY ATTACHED TO THE FENCE POST.

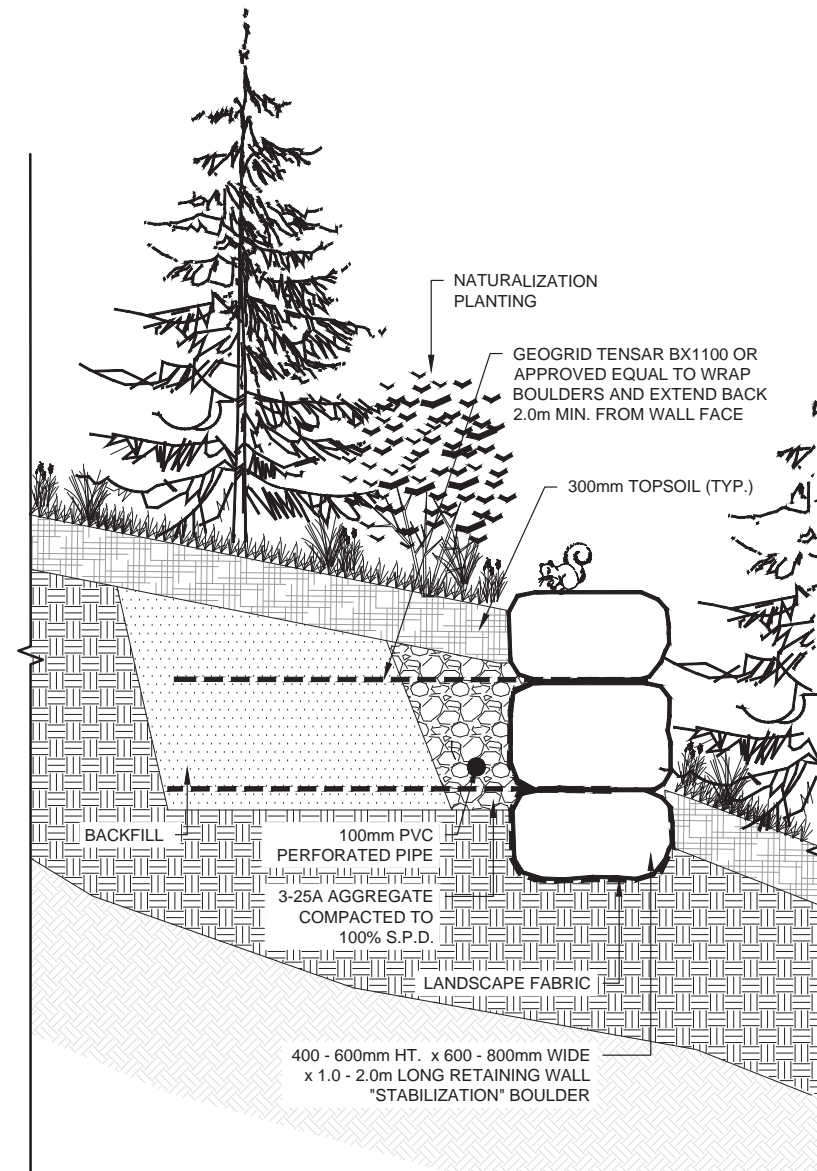

1 WILDLIFE FENCE
SCALE: 1:20

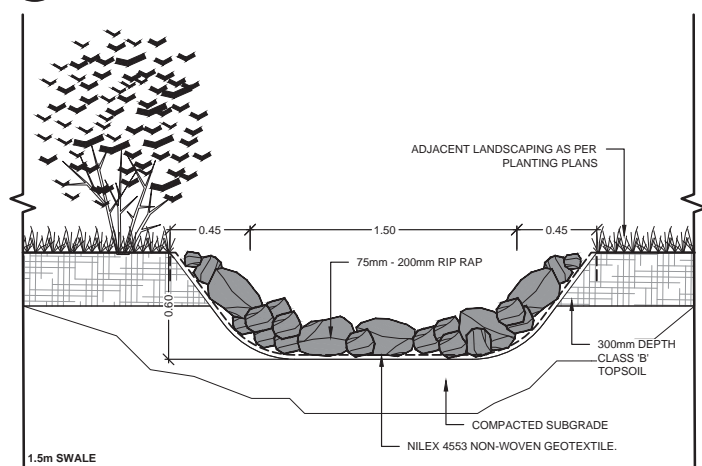

3 PERMANENT RIP RAP SWALE
SCALE: 1:20

2 STABILIZATION BOULDER RETAINING WALL INSTALLATION
SCALE: 1:40

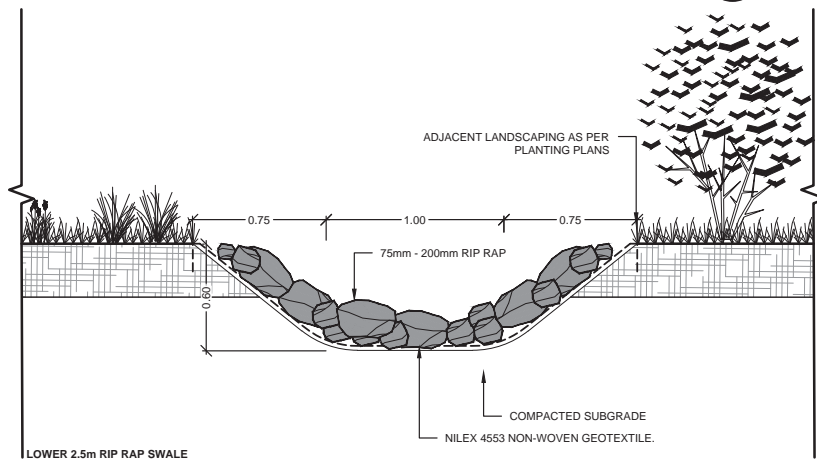

Stantec Consulting Ltd.
10160 - 112 Street
Edmonton AB Canada
Tel. 780.917.7000
www.stantec.com

Copyright Reserved
The Contractor shall verify and be responsible for all dimensions, DO NOT scale the drawing - any errors or omissions shall be reported to Stantec without delay. The Copyrights to all designs and drawings are the property of Stantec. Reproduction or use for any purpose other than that authorized by Stantec is forbidden.

Legend

Notes

UTILITY SETBACKS

LANDSCAPE CONTRACTOR TO CALL 'ALBERTA ONE-CALL' AT 1-800-242-3447 TO HAVE ALL EXISTING SITE UTILITIES LOCATED PRIOR TO CONSTRUCTION AND PLANT NO CLOSER THAN THE FOLLOWING DIMENSIONS FROM THE SERVICES:

1. 1.0m FROM POWER LINES
2. 3.5m FROM ALL POWER HARDWARE
3. 1.8m FROM WATER MAINS, WATER VALVES, MANUAL AIRVENTS, AND SERVICES
4. 2.0m FROM SEWER MAINS, AND MANHOLES
5. 1.8m FROM SEWER SERVICES
6. 1.5m FROM GAS (NO TREES WITHIN EASEMENT)
7. 7.5m FROM STREET CORNERS.
8. 3.5m FROM FIRE HYDRANTS.
9. 1.5m FROM DRIVEWAYS
10. 1.5m FROM ALLEY ACCESSES
11. 1.0m FROM SIDEWALKS OR AS PER APPROVED ENG. CROSS SECTIONS
12. 3.5m FROM TRANSIT ZONES
13. 3.0m FROM PRIVATE PROPERTY BOUNDARY
14. 1.25m FROM COLLECTOR ROAD CURB FACE
15. 1.25m FROM LOCAL ROAD CURB FACE
16. 2.0m FROM ARTERIAL ROAD CURB FACE
17. 3.5m FROM YIELD AND STOP SIGNS
18. 3.5m FROM BUS STOP SIGNS
19. 2.0m FROM ALL OTHER SIGNS
20. 1.0m FROM OTHER UNDERGROUND UTILITIES
21. 3.5m FROM TELUS PEDESTALS
22. 2.0m FROM TELUS DUCT STRUCTURE
23. 1.0m FROM TELUS CABLE FACILITIES

LANDSCAPE CONTRACTOR IS RESPONSIBLE FOR DAMAGES AND LIABILITIES INCURRED BY DAMAGES TO SITE UTILITIES.

Development Engineer, Sustainable Development			
Approvals			YY.MM.DD
Revision	By	Appd.	YY.MM.DD
1ST ISSUE FOR REVIEW	KM/KH/CB	DP	17.01.13
Issued	By	Appd.	YY.MM.DD
File Name: LA_AurumRavine.dwg	Dwn.	Chkd.	Dsgn.
			YY.MM.DD

Permit-Seal



David A. Price

Client/Project
AURUM INDUSTRIAL DEVELOPMENT PARTNERSHIP
AURUM ROAD
17 STREET NE TO 9 STREET NE
Edmonton, AB

Title
CREEK AND RAVINE RESTORATION LANDSCAPING DETAILS

Project No. 1161-104130 Scale AS SHOWN

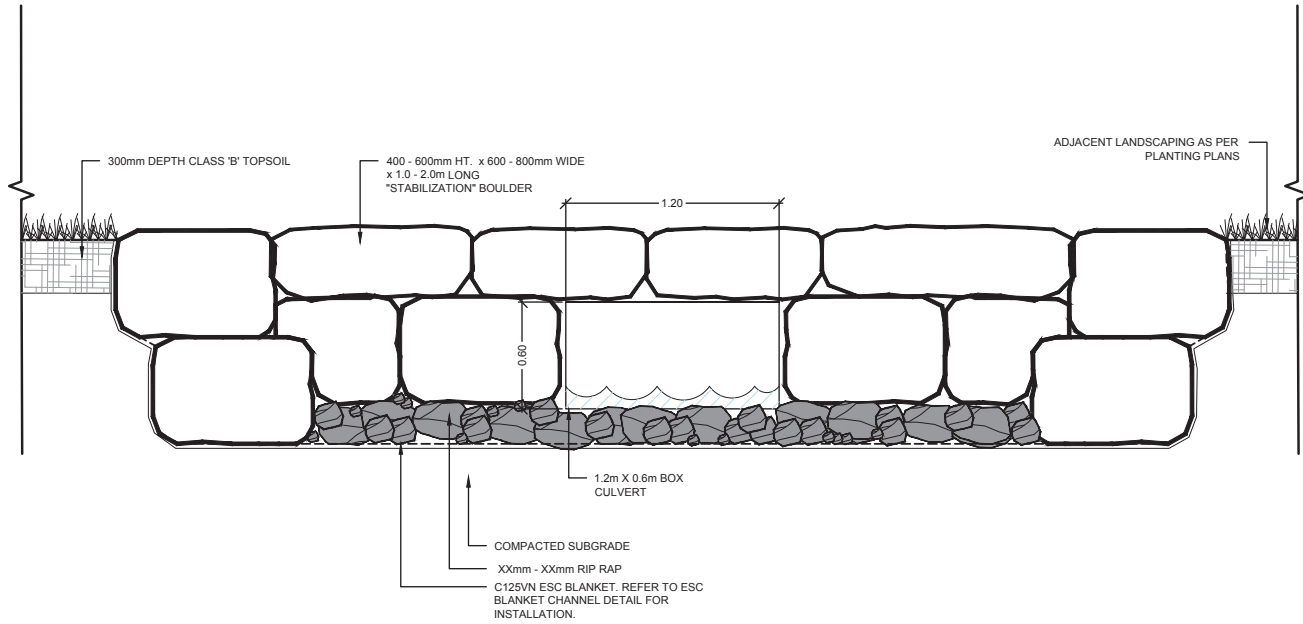

1 BOX CULVERT RIP RAP SWALE INTERFACE
SCALE: 1:20

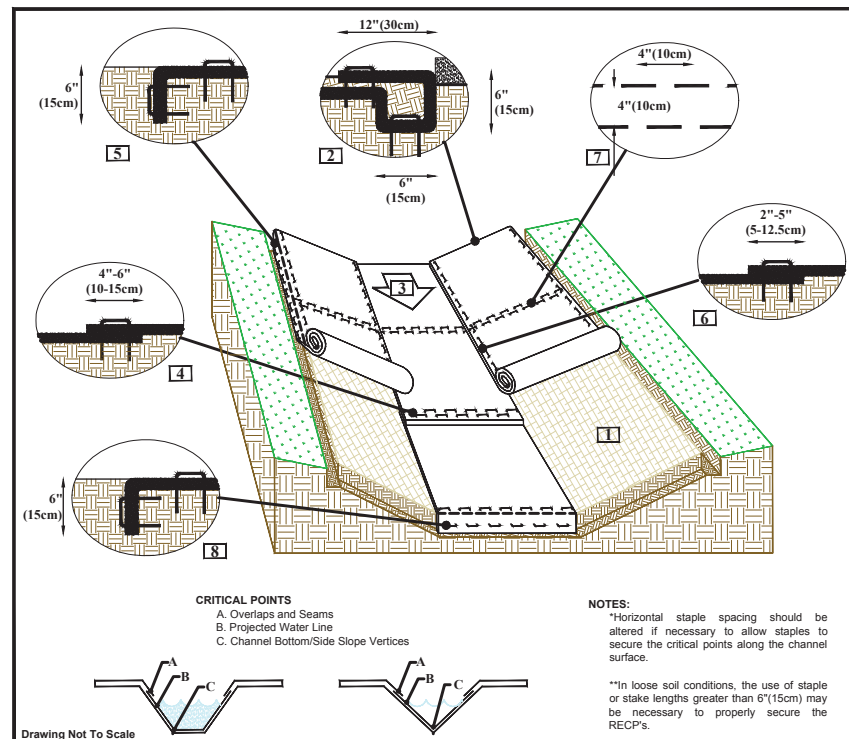

CHANNEL INSTALLATION DETAIL

- Prepare soil before installing rolled erosion control products (RECPs), including any necessary application of lime, fertilizer, and seed.
- Begin at the top of the channel by anchoring the RECPs in a 6" (15cm) deep x 6" (15cm) wide trench with approximately 12" (30cm) of RECPs extended beyond the up-slope portion of the trench. Use ShoreMax mat at the channel/culvert outlet as supplemental scour protection as needed. Anchor the RECPs with a row of staples/stakes approximately 12" (30cm) apart in the bottom of the trench. Backfill and compact the trench after stapling. Apply seed to the compacted soil and fold the remaining 12" (30cm) portion of RECPs back over the seed and compacted soil. Secure RECPs over compacted soil with a row of staples/stakes spaced approximately 12" apart across the width of the RECPs.
- Roll center RECPs in direction of water flow in bottom of channel. RECPs will unroll with appropriate side against the soil surface. All RECPs must be securely fastened to soil surface by placing staples/stakes in appropriate locations as shown in the staple pattern guide.
- Place consecutive RECPs end-over-end (Single style) with a 4" overlap. Use a double row of staples staggered 4" apart and 4" on center to secure RECPs.
- Full length edge of RECPs at top of side slopes must be anchored with a row of staples/stakes approximately 12" (30cm) apart in a 6" (15cm) deep x 6" (15cm) wide trench. Backfill and compact the trench after stapling.
- Adjacent RECPs must be overlapped approximately 2" - 5" (5-12.5cm) (Depending on RECPs type) and stapled.
- In high flow channel applications, a staple check slot is recommended at 30 to 40 foot (9-12m) intervals. Use a double row of staples staggered 4" (10cm) apart and 4" (10cm) on center over entire width of the channel.
- The terminal end of the RECPs must be anchored with a row of staples/stakes approximately 12" (30cm) apart in a 6" (15cm) deep x 6" (15cm) wide trench. Backfill and compact the trench after stapling.

CRITICAL POINTS
A. Overlaps and Seams
B. Projected Water Line
C. Channel Bottom/Side Slope Vertices

NOTES:
*Horizontal staple spacing should be altered if necessary to allow staples to secure the critical points along the channel surface.
**In loose soil conditions, the use of staple or stake lengths greater than 6" (15cm) may be necessary to properly secure the RECPs.

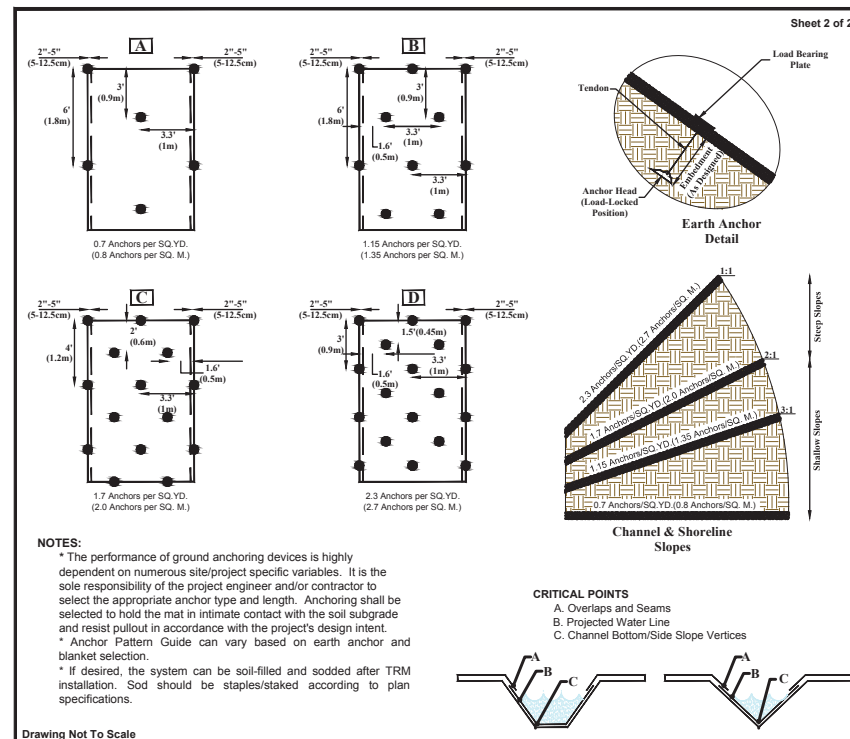

SLOPE INSTALLATION EARTH ANCHOR (EA) DETAIL

- Prepare soil before installing high-performance turf reinforcement mats (HP-TRMs), including any necessary application of lime, fertilizer, and seed.
- Begin at the top of the slope by anchoring the HP-TRMs in a 6" (15 cm) deep x 6" (15cm) wide trench with approximately 12" (30 cm) of HP-TRMs extended beyond the up-slope portion of the trench. Anchor the HP-TRMs with a row of staples and anchors approximately 12" (30 cm) apart in the bottom of the trench. Backfill and compact the trench after stapling. Apply seed to the compacted soil and fold remaining 12" (30 cm) portion of HP-TRMs back over seed and compacted soil. Secure HP-TRMs over compacted soil with a row of staples/stakes spaced approximately 12" (30 cm) apart across the width of the HP-TRMs.
- Roll the HP-TRMs (A) down or (B) horizontally across the slope. HP-TRMs will unroll with appropriate side against the soil surface. All HP-TRMs must be securely fastened to soil surface by placing staples/stakes in appropriate locations as shown in the staple pattern guide.
- The edges of parallel HP-TRMs must be stapled with approximately 2" - 5" (5-12.5cm) overlap depending on the HP-TRM type.
- Consecutive HP-TRMs spliced down the slope must be end over end (Shingle style) with an approximate 3"(7.5cm) overlap. Staple through overlapped area, approximately 12"(30cm) apart across entire HP-TRM width.

CRITICAL POINTS
A. Overlaps and Seams
B. Projected Water Line
C. Channel Bottom/Side Slope Vertices

NOTES:
* The performance of ground anchoring devices is highly dependent on numerous site/project specific variables. It is the sole responsibility of the project engineer and/or contractor to select the appropriate anchor type and length. Anchoring shall be selected to hold the mat in intimate contact with the soil subgrade and resist pullout in accordance with the project's design intent.
* Anchor Pattern Guide can vary based on earth anchor and blanket selection.
* If desired, the system can be soil-filled and sodded after TRM installation. Sod should be staples/staked according to plan specifications.

2 NILEX XXX CHANNEL AND ANCHOR INSTALLATION
SCALE: N.T.S.



Stantec Consulting Ltd.
10160 - 112 Street
Edmonton AB Canada
Tel. 780.917.7000
www.stantec.com

Copyright Reserved
The Contractor shall verify and be responsible for all dimensions. DO NOT scale the drawing - any errors or omissions shall be reported to Stantec without delay. The Copyrights to all designs and drawings are the property of Stantec. Reproduction or use for any purpose other than that authorized by Stantec is forbidden.

Legend

Notes
UTILITY SETBACKS
LANDSCAPE CONTRACTOR TO CALL 'ALBERTA ONE-CALL' AT 1-800-242-3447 TO HAVE ALL EXISTING SITE UTILITIES LOCATED PRIOR TO CONSTRUCTION AND PLANT NO CLOSER THAN THE FOLLOWING DIMENSIONS FROM THE SERVICES:

- 1.0m FROM POWER LINES
- 3.5m FROM ALL POWER HARDWARE
- 1.8m FROM WATER MAINS, WATER VALVES, MANUAL AIRVENTS, AND SERVICES
- 2.0m FROM SEWER MAINS, AND MANHOLES
- 1.8m FROM SEWER SERVICES
- 1.5m FROM GAS (NO TREES WITHIN EASEMENT)
- 7.5m FROM STREET CORNERS.
- 3.5m FROM FIRE HYDRANTS.
- 1.5m FROM DRIVEWAYS
- 1.5m FROM ALLEY ACCESSES
- 1.0m FROM SIDEWALKS
- OR AS PER APPROVED ENG. CROSS SECTIONS
- 3.5m FROM TRANSIT ZONES
- 3.0m FROM PRIVATE PROPERTY BOUNDARY
- 1.25m FROM COLLECTOR ROAD CURB FACE
- 1.25m FROM LOCAL ROAD CURB FACE
- 2.0m FROM ARTERIAL ROAD CURB FACE
- 3.5m FROM YIELD AND STOP SIGNS
- 3.5m FROM BUS STOP SIGNS
- 2.0m FROM ALL OTHER SIGNS
- 1.0m FROM OTHER UNDERGROUND UTILITIES
- 3.5m FROM TELUS PEDESTALS
- 2.0m FROM TELUS DUCT STRUCTURE
- 1.0m FROM TELUS CABLE FACILITIES

LANDSCAPE CONTRACTOR IS RESPONSIBLE FOR DAMAGES AND LIABILITIES INCURRED BY DAMAGES TO SITE UTILITIES.

Development Engineer, Sustainable Development			
Approvals			YY.MM.DD
Revision			
1ST ISSUE FOR REVIEW	KM/KH/CB	DP	17.01.13
Issued		By Appd.	YY.MM.DD
File Name: LA_AurumRavine.dwg		Dwn. Chkd. Dgtn.	YY.MM.DD

Permit-Seal



Client/Project
AURUM INDUSTRIAL DEVELOPMENT PARTNERSHIP
AURUM ROAD 17 STREET NE TO 9 STREET NE
Edmonton, AB

Title
CREEK AND RAVINE RESTORATION LANDSCAPING DETAILS

Project No. 1161-104130
Scale AS SHOWN

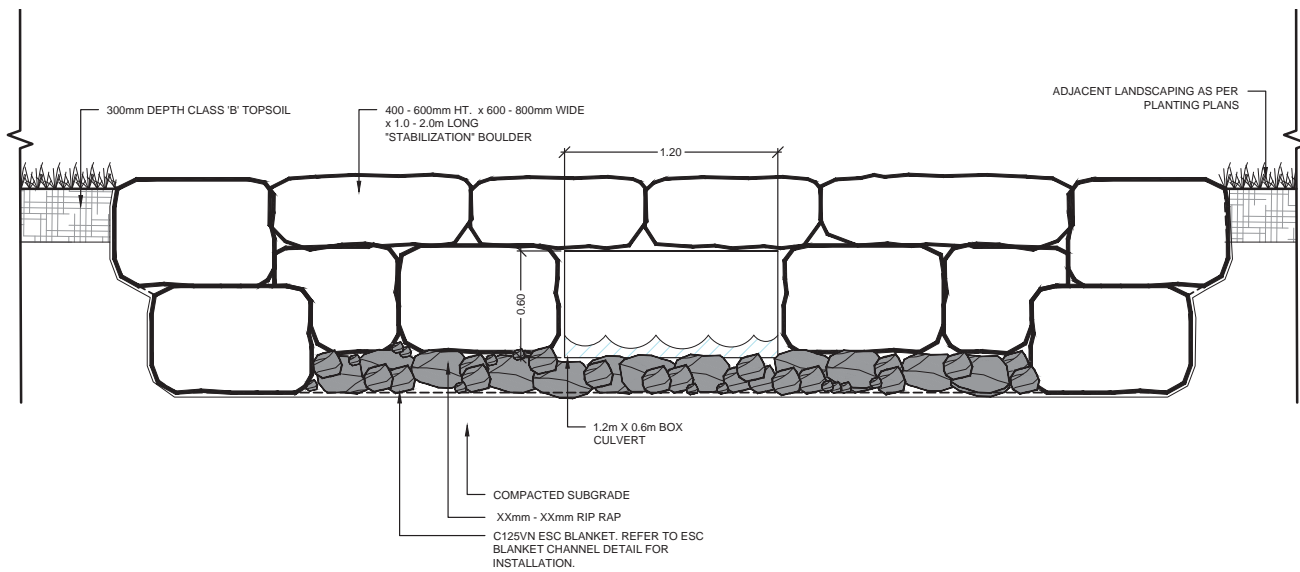

1 BOX CULVERT RIP RAP SWALE INTERFACE
SCALE: 1:20

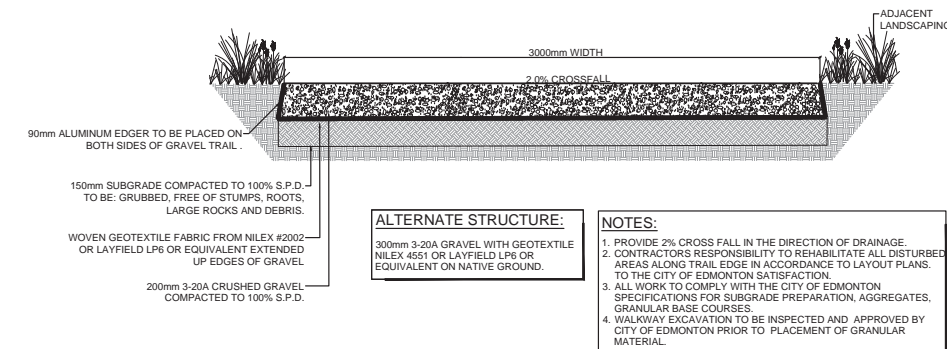

2 GRAVEL ACCESS TRAIL
SCALE: 1:20

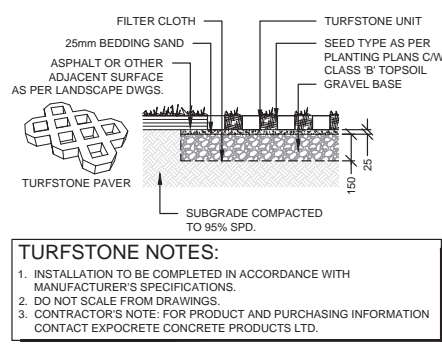

3 TURFSTONE ACCESS TRAIL
SCALE: 1:20

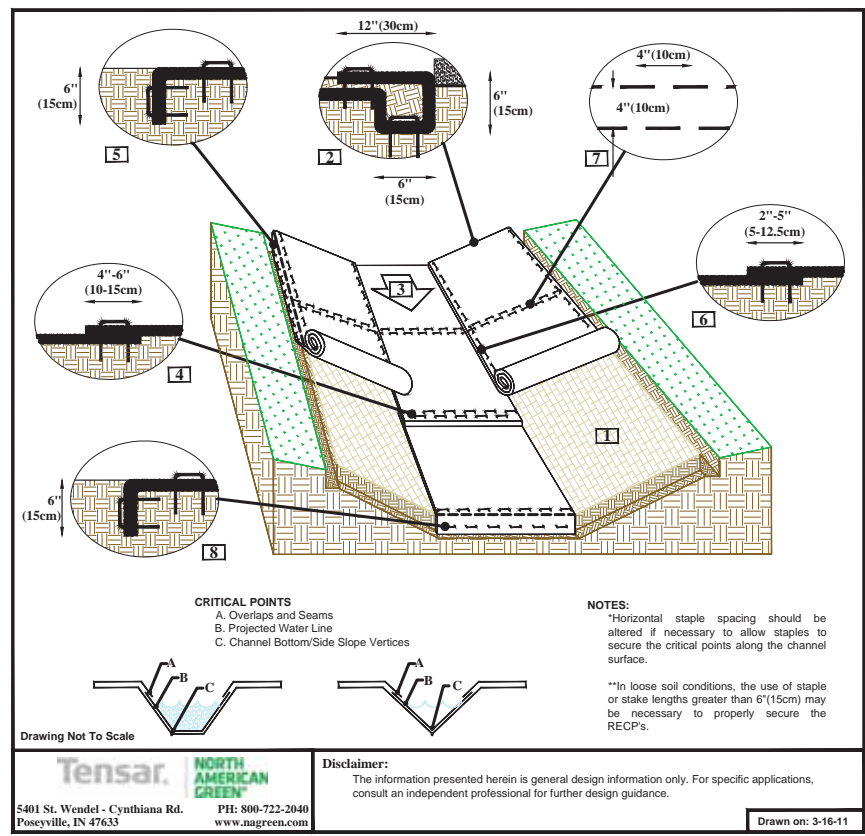

CHANNEL INSTALLATION DETAIL

- Prepare soil before installing rolled erosion control products (RECPs), including any necessary application of lime, fertilizer, and seed.
- Begin at the top of the channel by anchoring the RECPs in a 6"(15cm) deep X 6"(15cm) wide trench with approximately 12"(30cm) of RECPs extended beyond the up-slope portion of the trench. Use ShoreMat mat at the bottom of the trench. Backfill and compact the trench after stapling. Apply seed to the compacted soil and fold the remaining 12"(30cm) portion of RECPs back over the seed and compacted soil. Secure RECPs over compacted soil with a row of staples/stakes spaced approximately 12" apart across the width of the RECPs.
- Roll center RECPs in direction of water flow in bottom of channel. RECPs will unroll with appropriate side against the soil surface. All RECPs must be securely fastened to soil surface by placing staples/stakes in appropriate locations as shown in the staple pattern guide.
- Place consecutive RECPs end-over-end (Single style) with a 4"-6" (10-15cm) overlap. Use a double row of staples staggered 4" apart and 4" on center to secure RECPs.
- Full length edge of RECPs at top of side slopes must be anchored with a row of staples/stakes approximately 12"(30cm) apart in a 6"(15cm) deep X 6"(15cm) wide trench. Backfill and compact the trench after stapling.
- Adjacent RECPs must be overlapped approximately 2"-5" (5-12.5cm) (Depending on RECPs type) and stapled.
- In high flow channel applications, a staple check slot is recommended at 30 to 40 foot (9-12m) intervals. Use a double row of staples staggered 4"(10cm) apart and 4"(10cm) on center over entire width of the channel.
- The terminal end of the RECPs must be anchored with a row of staples/stakes approximately 12" (30cm) apart in a 6"(15cm) deep X 6"(15cm) wide trench. Backfill and compact the trench after stapling.

CRITICAL POINTS
A. Overlaps and Seams
B. Projected Water Line
C. Channel Bottom/Side Slope Vertices

NOTES:
*Horizontal staple spacing should be altered if necessary to allow staples to secure the critical points along the channel surface.
**In loose soil conditions, the use of staple or stake lengths greater than 6"(15cm) may be necessary to properly secure the RECPs.

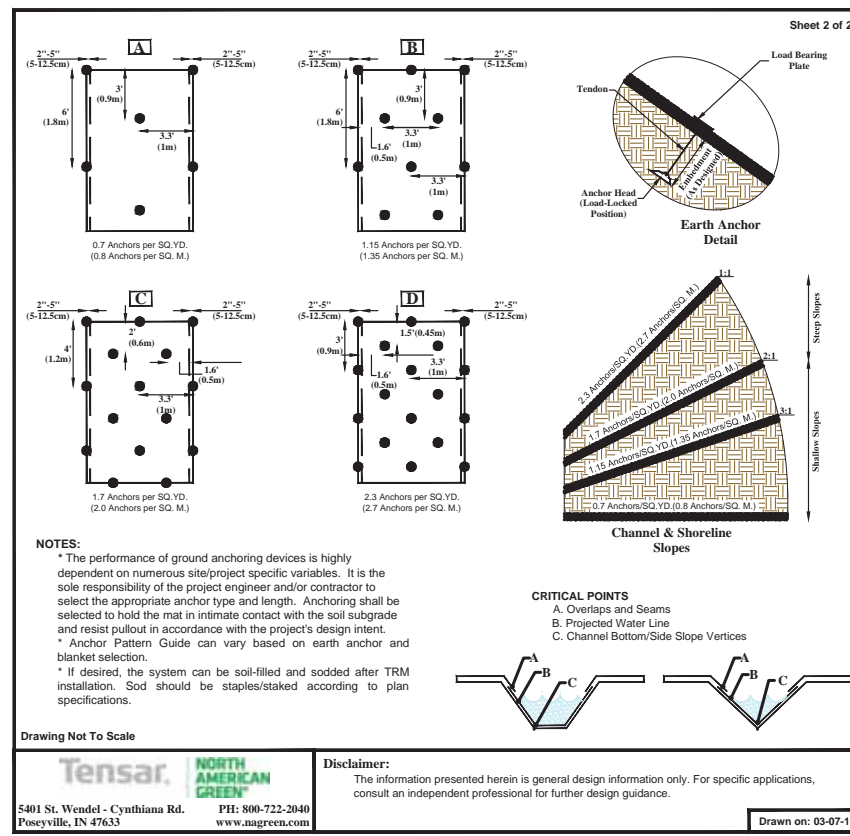

SLOPE INSTALLATION EARTH ANCHOR (EA) DETAIL

- Prepare soil before installing high-performance turf reinforcement mats (HP-TRMs), including any necessary application of lime, fertilizer, and seed.
- Begin at the top of the slope by anchoring the HP-TRMs in a 6" (15 cm) deep x 6" (15cm) wide trench with approximately 12" (30 cm) of HP-TRMs extended beyond the up-slope portion of the trench. Anchor the HP-TRMs with a row of staples and anchors approximately 12" (30 cm) apart in the bottom of the trench. Backfill and compact the trench after stapling. Apply seed to compacted soil and fold remaining 12" (30 cm) portion of HP-TRMs back over seed and compacted soil. Secure HP-TRMs over compacted soil with a row of staples/stakes spaced approximately 12" (30 cm) apart across the width of the HP-TRMs.
- Roll the HP-TRMs (A) down or (B) horizontally across the slope. HP-TRMs will unroll with appropriate side against the soil surface. All HP-TRMs must be securely fastened to soil surface by placing staples/stakes in appropriate locations as shown in the staple pattern guide.
- The edges of parallel HP-TRMs must be stapled with approximately 2" - 5" (5-12.5cm) overlap depending on the HP-TRM type.
- Consecutive HP-TRMs spliced down the slope must be end over end (Single style) with an approximate 3"(7.5cm) overlap. Staple through overlapped area, approximately 12"(30cm) apart across entire HP-TRM width.

CRITICAL POINTS
A. Overlaps and Seams
B. Projected Water Line
C. Channel Bottom/Side Slope Vertices

NOTES:
* The performance of ground anchoring devices is highly dependent on numerous site/project specific variables. It is the sole responsibility of the project engineer and/or contractor to select the appropriate anchor type and length. Anchoring shall be selected to hold the mat in intimate contact with the soil subgrade and resist pullout in accordance with the project's design intent.
* Anchor Pattern Guide can vary based on earth anchor and blanket selection.
* If desired, the system can be soil-filled and sodded after TRM installation. Sod should be stapled/staked according to plan specifications.



Stantec Consulting Ltd.
10160 - 112 Street
Edmonton AB Canada
Tel. 780.917.7000
www.stantec.com

Copyright Reserved
The Contractor shall verify and be responsible for all dimensions. DO NOT scale the drawing - any errors or omissions shall be reported to Stantec without delay. The Copyrights to all designs and drawings are the property of Stantec. Reproduction or use for any purpose other than that authorized by Stantec is forbidden.

Legend

Notes
UTILITY SETBACKS
LANDSCAPE CONTRACTOR TO CALL 'ALBERTA ONE-CALL' AT 1-800-242-3447 TO HAVE ALL EXISTING SITE UTILITIES LOCATED PRIOR TO CONSTRUCTION AND PLANT NO CLOSER THAN THE FOLLOWING DIMENSIONS FROM THE SERVICES:

- 1.0m FROM POWER LINES
- 3.5m FROM ALL POWER HARDWARE
- 1.8m FROM WATER MAINS, WATER VALVES, MANUAL AIRVENTS, AND SERVICES
- 2.0m FROM SEWER MAINS, AND MANHOLES
- 1.8m FROM SEWER SERVICES
- 1.5m FROM GAS (NO TREES WITHIN EASEMENT)
- 7.5m FROM STREET CORNERS.
- 3.5m FROM FIRE HYDRANTS.
- 1.5m FROM DRIVEWAYS
- 1.5m FROM ALLEY ACCESSSES
- 1.0m FROM SIDEWALKS OR AS PER APPROVED ENG. CROSS SECTIONS
- 3.5m FROM TRANSIT ZONES
- 3.0m FROM PRIVATE PROPERTY BOUNDARY
- 1.25m FROM COLLECTOR ROAD CURB FACE
- 1.25m FROM LOCAL ROAD CURB FACE
- 2.0m FROM ARTERIAL ROAD CURB FACE
17. 3.5m FROM YIELD AND STOP SIGNS
- 3.5m FROM BUS STOP SIGNS
- 2.0m FROM ALL OTHER SIGNS
- 1.0m FROM OTHER UNDERGROUND UTILITIES
- 3.5m FROM TELUS PEDESTALS
- 2.0m FROM TELUS DUCT STRUCTURE
- 1.0m FROM TELUS CABLE FACILITIES

LANDSCAPE CONTRACTOR IS RESPONSIBLE FOR DAMAGES AND LIABILITIES INCURRED BY DAMAGES TO SITE UTILITIES.

Development Engineer, Sustainable Development			
Approvals			YY.MM.DD
Revision			
1ST ISSUE FOR REVIEW	KM/KH/CB	DP	17.01.13
Issued			YY.MM.DD
File Name: LA_AurumRavine.dwg	Own.	Chkd.	Dsgn.
Permit-Seal			YY.MM.DD



David A. Price
Client/Project
AURUM INDUSTRIAL DEVELOPMENT PARTNERSHIP
AURUM ROAD
17 STREET NE TO 9 STREET NE
Edmonton, AB

Title
CREEK AND RAVINE RESTORATION LANDSCAPING DETAILS

Project No. 1161-104130 Scale AS SHOWN

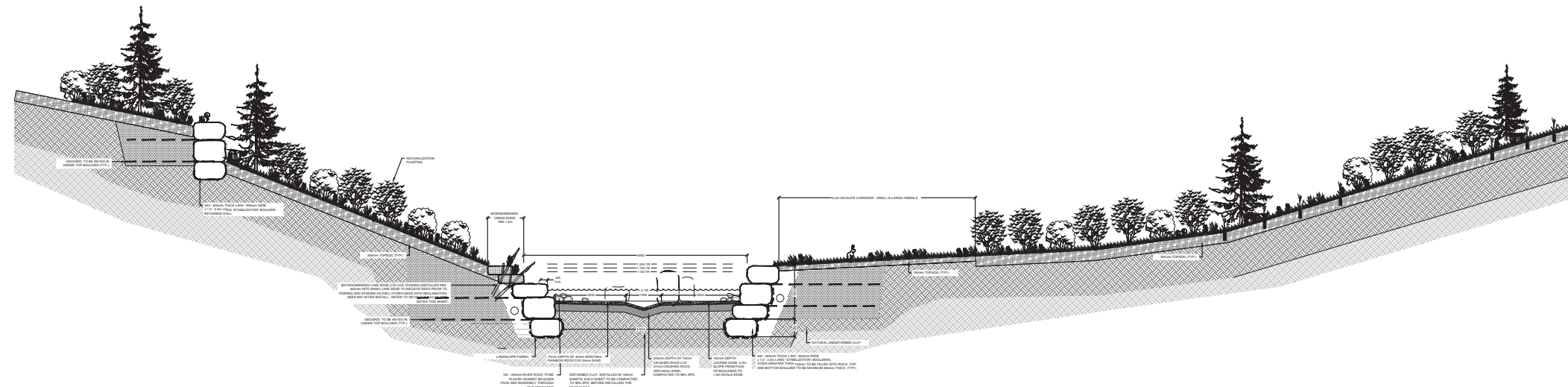

1 SECTION 1 - RIFFLE NATURALIZED
SCALE: 1:75

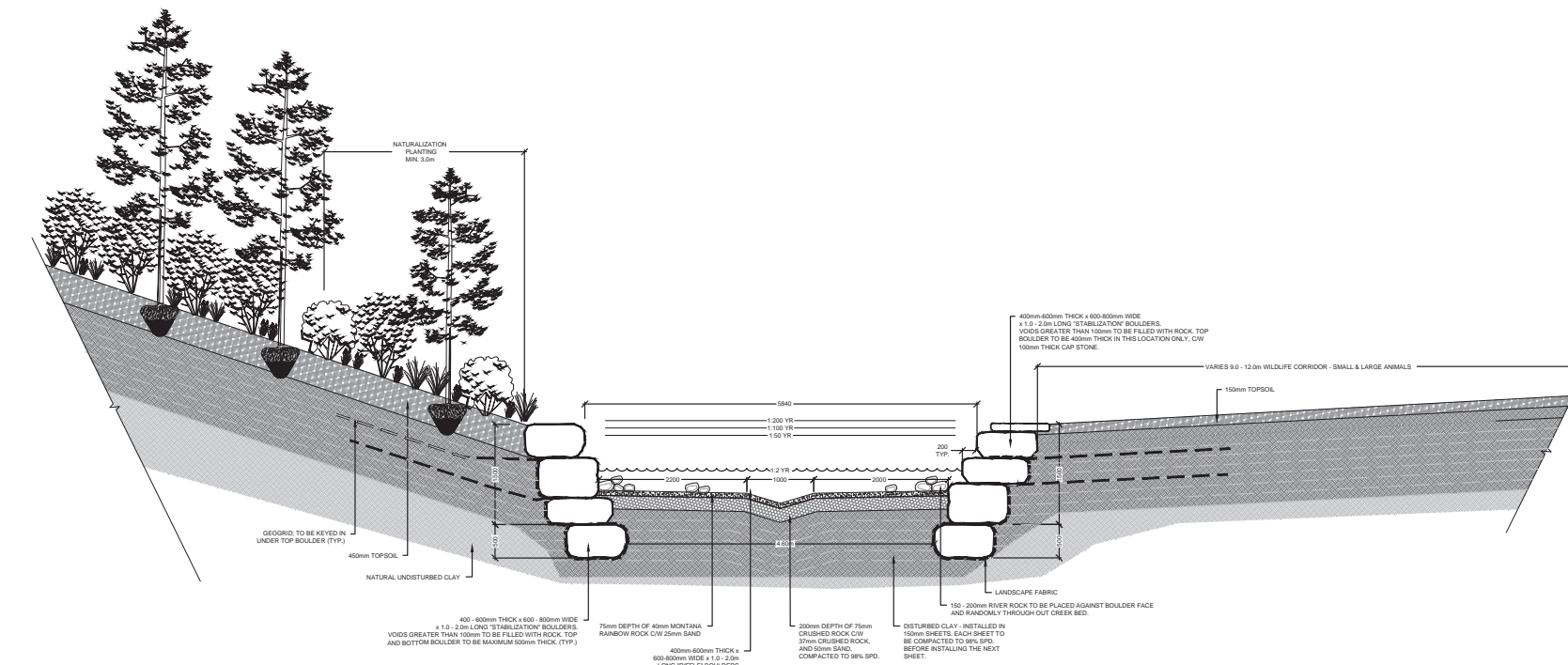

2 SECTION 2 - RUN NATURALIZED
SCALE: 1:50

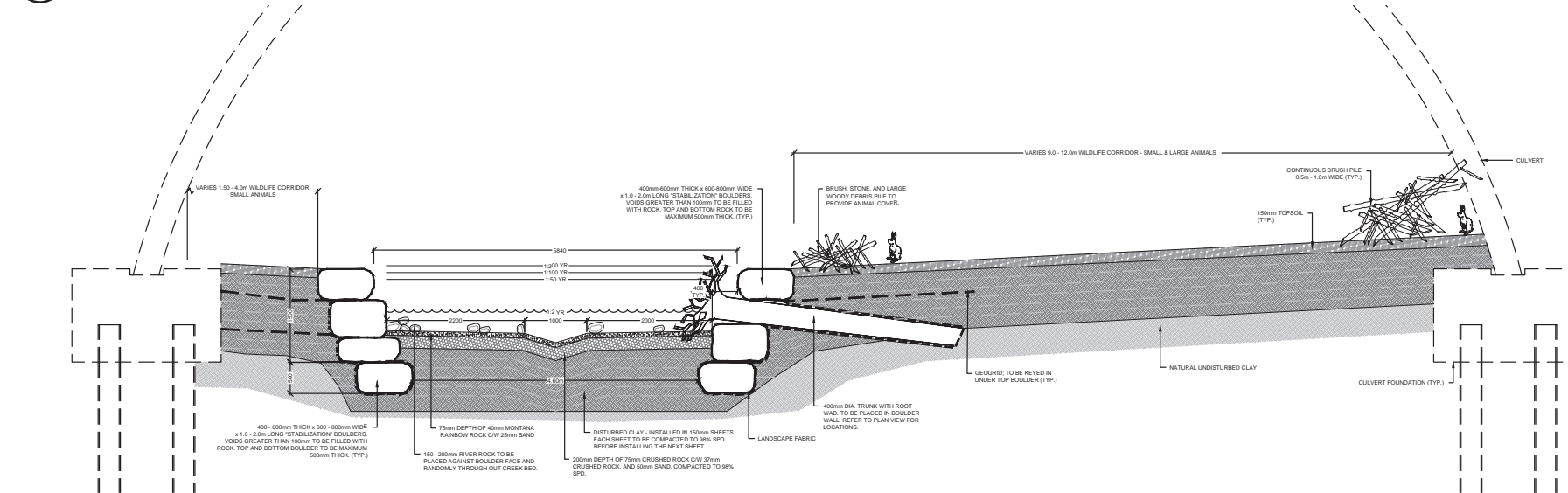

3 SECTION 3 - RUN CHANNELIZED
SCALE: 1:50



Stantec Consulting Ltd.
10160 - 112 Street
Edmonton AB Canada
Tel. 780.917.7000
www.stantec.com

Copyright Reserved

The Contractor shall verify and be responsible for all dimensions. DO NOT scale the drawing - any errors or omissions shall be reported to Stantec without delay. The Copyrights to all designs and drawings are the property of Stantec. Reproduction or use for any purpose other than that authorized by Stantec is forbidden.

Legend

Notes

Development Engineer, Sustainable Development			
Approvals			YY.MM.DD
Revision	By	Appd.	YY.MM.DD
1ST ISSUE FOR REVIEW	KM/KH/CB	DP	17.01.13
Issued	By	Appd.	YY.MM.DD
File Name: LA_AurumRoad_Bioretenion.dwg	Dwn.	Chkd.	Dsgn.
			YY.MM.DD

Permit-Seal



David A. Price

Client/Project
AURUM INDUSTRIAL
DEVELOPMENT PARTNERSHIP
AURUM ROAD
17 STREET NE TO 9 STREET NE
Edmonton, AB

Title
CREEK AND RAVINE RESTORATION
CROSS SECTION DETAILS

Project No. 1161-104130 Scale AS SHOWN

V:\1161\Aurum\1161-104130\Drawings\Landscape\Aurum
Road\LA_AurumRoad_Bioretenion.dwg Drawing No. L200-009
2017-1-19 3:28pm BY: KHURST 9 of 11

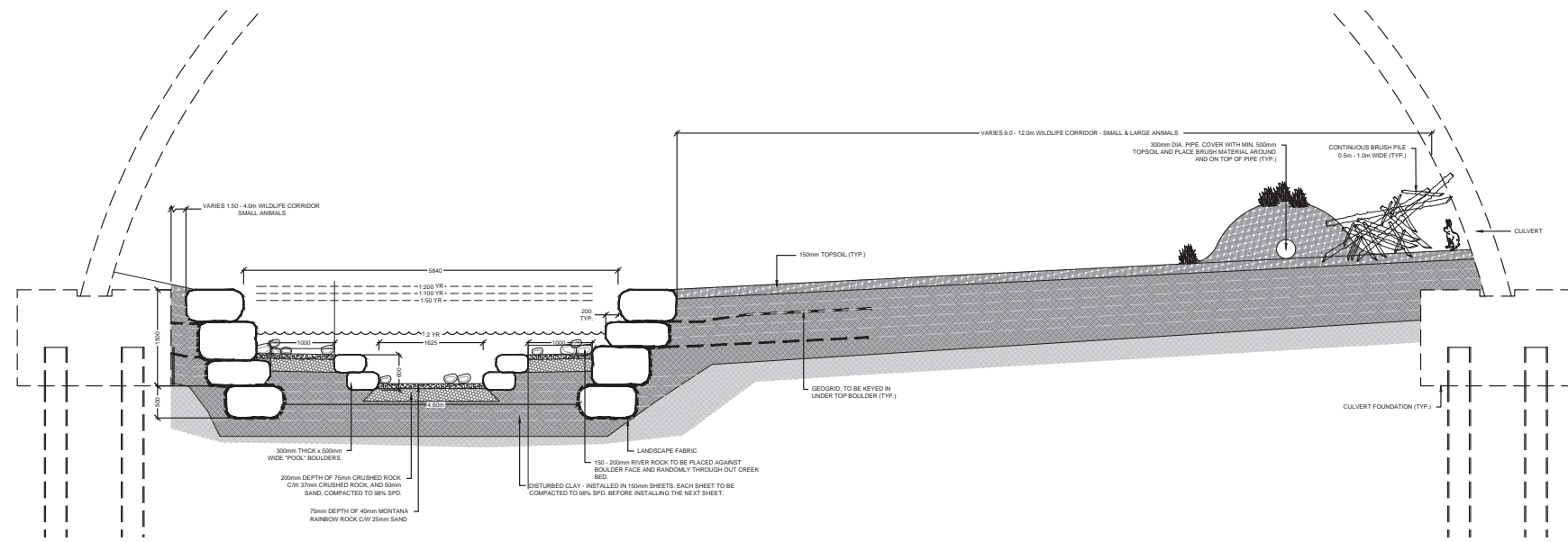

1 SECTION 4 - DEEP POOL CHANNELIZED
SCALE: 1:50

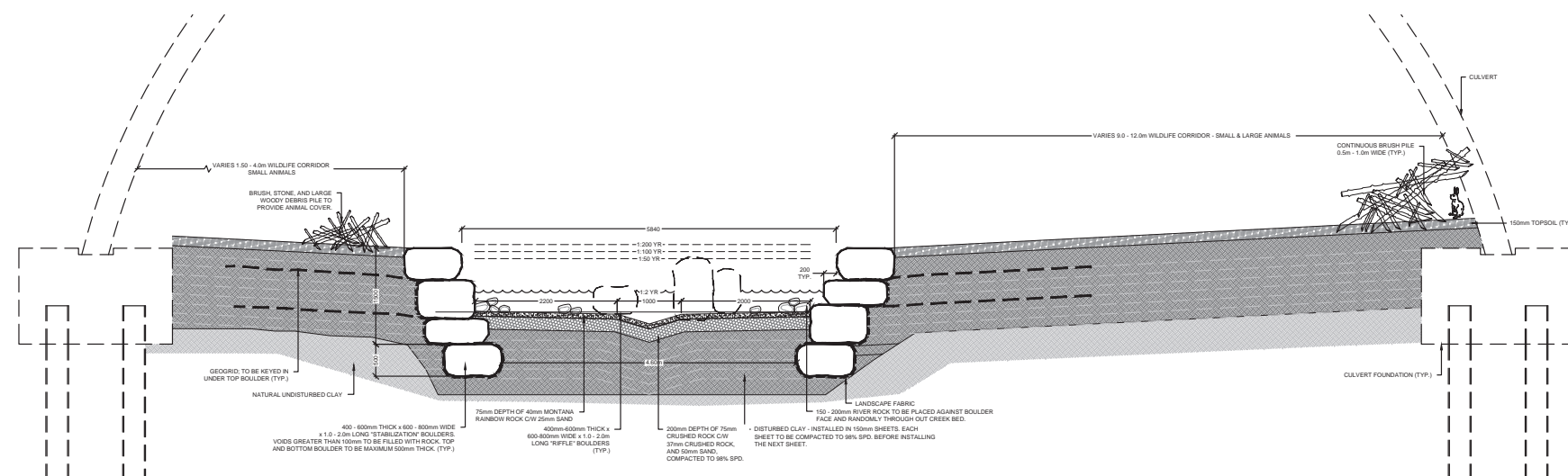

2 SECTION 5 - RIFFLE CHANNELIZED
SCALE: 1:50

3 BRUSH LAYERING INSTALLATION
SCALE: 1:50



Stantec Consulting Ltd.
10160 - 112 Street
Edmonton AB Canada
Tel. 780.917.7000
www.stantec.com

Copyright Reserved

The Contractor shall verify and be responsible for all dimensions. DO NOT scale the drawing - any errors or omissions shall be reported to Stantec without delay. The Copyrights to all designs and drawings are the property of Stantec. Reproduction or use for any purpose other than that authorized by Stantec is forbidden.

Legend

Notes

Development Engineer, Sustainable Development			
Approvals			YY.MM.DD
Revision	By	Appd.	YY.MM.DD
1ST ISSUE FOR REVIEW	KM/KH/CB	DP	17.01.13
Issued	By	Appd.	YY.MM.DD
File Name: LA_AurumRoad_Borenton.dwg	Dwn.	Chkd.	Dsgn.
			YY.MM.DD

Permit-Seal



David A. Price

Client/Project
AURUM INDUSTRIAL
DEVELOPMENT PARTNERSHIP
AURUM ROAD
17 STREET NE TO 9 STREET NE
Edmonton, AB

Title
CREEK AND RAVINE ALIGNMENT
CROSS SECTION DETAILS

Project No. 1161-104130 Scale AS SHOWN

V:\1161\Aurum\1161-104130\drawing_Landscape\Aurum
Road\LA_AurumRoad_Borenton.dwg Drawing No.
2017-1-19 3:29pm BY:KHURST 10 of 11 L200-010

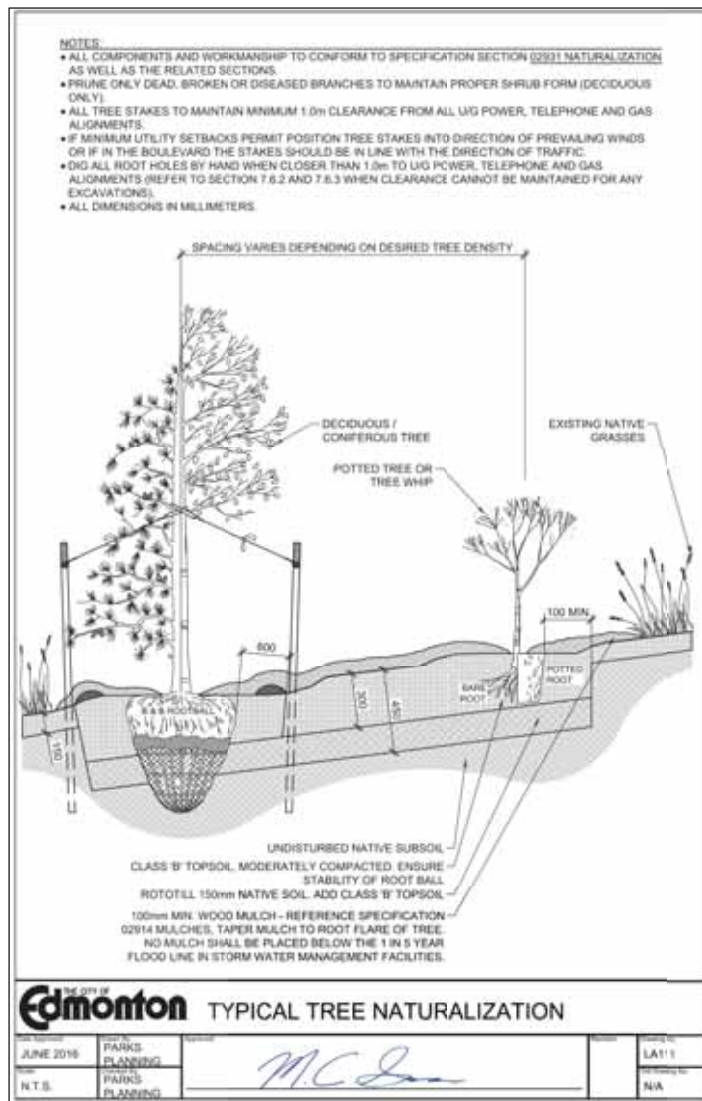

1 TYPICAL TREE NATURALIZATION
SCALE: N.T.S.

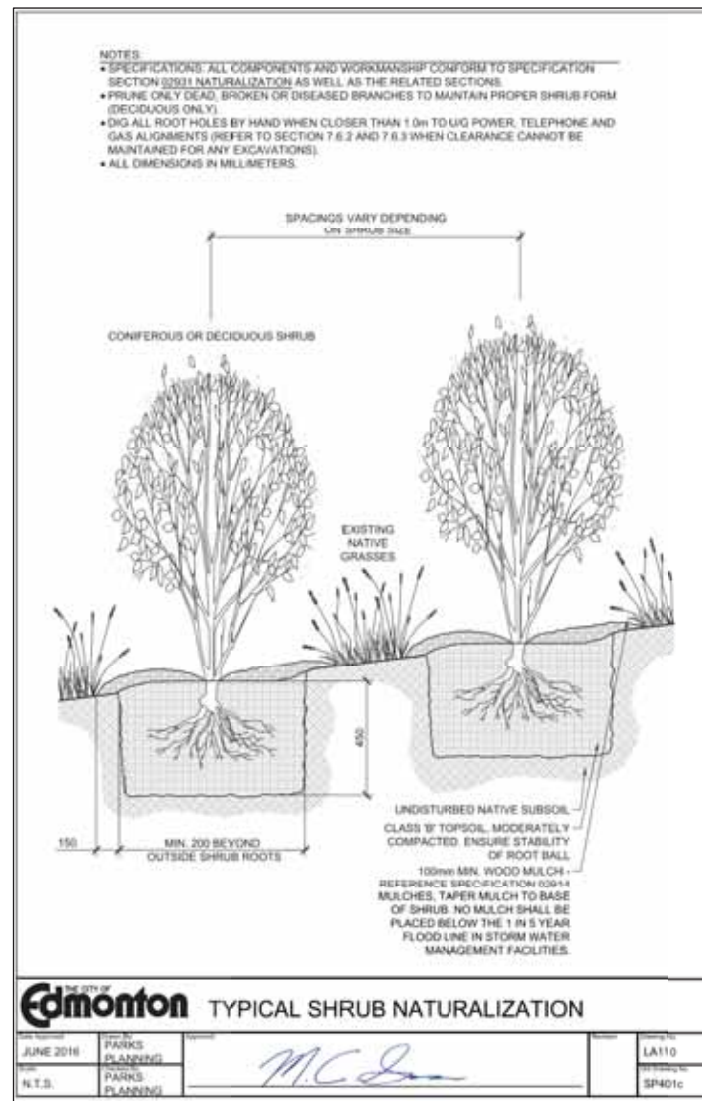

2 TYPICAL SHRUB NATURALIZATION
SCALE: N.T.S.

3 PLANT PLUG INSTALLATION
SCALE: N.T.S.



Stantec Consulting Ltd.
10160 - 112 Street
Edmonton AB Canada
Tel. 780.917.7000
www.stantec.com

Copyright Reserved
The Contractor shall verify and be responsible for all dimensions. DO NOT scale the drawing - any errors or omissions shall be reported to Stantec without delay. The Copyrights to all designs and drawings are the property of Stantec. Reproduction or use for any purpose other than that authorized by Stantec is forbidden.

Legend

Notes
UTILITY SETBACKS

LANDSCAPE CONTRACTOR TO CALL 'ALBERTA ONE-CALL' AT 1-800-242-3447 TO HAVE ALL EXISTING SITE UTILITIES LOCATED PRIOR TO CONSTRUCTION AND PLANT NO CLOSER THAN THE FOLLOWING DIMENSIONS FROM THE SERVICES:

1. 1.0m FROM POWER LINES
2. 3.5m FROM ALL POWER HARDWARE
3. 1.8m FROM WATER MAINS, WATER VALVES, MANUAL AIRVENTS, AND SERVICES
4. 2.0m FROM SEWER MAINS, AND MANHOLES
5. 1.8m FROM SEWER SERVICES
6. 1.5m FROM GAS (NO TREES WITHIN EASEMENT)
7. 7.5m FROM STREET CORNERS.
8. 3.5m FROM FIRE HYDRANTS.
9. 1.5m FROM DRIVEWAYS
10. 1.5m FROM ALLEY ACCESSES
11. 1.0m FROM SIDEWALKS
- OR AS PER APPROVED ENG. CROSS SECTIONS
12. 3.5m FROM TRANSIT ZONES
13. 3.0m FROM PRIVATE PROPERTY BOUNDARY
14. 1.25m FROM COLLECTOR ROAD CURB FACE
15. 1.25m FROM LOCAL ROAD CURB FACE
16. 2.0m FROM ARTERIAL ROAD CURB FACE
17. 3.5m FROM YIELD AND STOP SIGNS
18. 3.5m FROM BUS STOP SIGNS
19. 2.0m FROM ALL OTHER SIGNS
20. 1.0m FROM OTHER UNDERGROUND UTILITIES
21. 3.5m FROM TELUS PEDESTALS
22. 2.0m FROM TELUS DUCT STRUCTURE
23. 1.0m FROM TELUS CABLE FACILITIES

LANDSCAPE CONTRACTOR IS RESPONSIBLE FOR DAMAGES AND LIABILITIES INCURRED BY DAMAGES TO SITE UTILITIES.

Development Engineer, Sustainable Development			
Approvals			YY.MM.DD
Revision	By	Appd.	YY.MM.DD
1ST ISSUE FOR REVIEW	KMKH/CB	DP	17.01.13
Issued	By	Appd.	YY.MM.DD
File Name: LA_AurumRavine.dwg	Dwn.	Chkd.	Dgtn.
			YY.MM.DD

Permit-Seal



David A. Price

Client/Project
AURUM INDUSTRIAL
DEVELOPMENT PARTNERSHIP
AURUM ROAD
17 STREET NE TO 9 STREET NE
Edmonton, AB

Title
CREEK AND RAVINE RESTORATION
PLANTING DETAILS

Project No. 1161-104130 Scale AS SHOWN



APPENDIX B
VEGETATION TECHNICAL DATA REPORT

**Aurum Project,
SE 21-53-23 W4M**

Technical Data Report
Vegetation



Prepared for:
Aurum Industrial Development
Partnership

Prepared by:
Stantec Consulting Ltd
Edmonton, Alberta

December 2016
110219671

Sign-off Sheet

This document entitled Aurum Project, SE 21-53-23 W4M was prepared by Stantec Consulting Ltd. ("Stantec") for the account of Aurum Industrial Development Partnership (the "Client"). Any reliance on this document by any third party is strictly prohibited. The material in it reflects Stantec's professional judgment in light of the scope, schedule and other limitations stated in the document and in the contract between Stantec and the Client. The opinions in the document are based on conditions and information existing at the time the document was published and do not take into account any subsequent changes. In preparing the document, Stantec did not verify information supplied to it by others. Any use which a third party makes of this document is the responsibility of such third party. Such third party agrees that Stantec shall not be responsible for costs or damages of any kind, if any, suffered by it or any other third party as a result of decisions made or actions taken based on this document.



Prepared by _____
(signature)

Ben Steele, ATT
Environmental Scientist



Reviewed by _____
(signature)

Jessica Feschuk, M.Sc., P.Biol.
Vegetation Ecologist

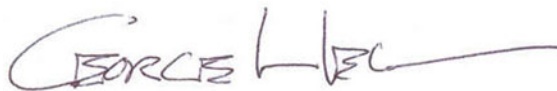

Approved by _____
(signature)

George Hegmann, B.Eng., M.E.Des., P.Eng.
Senior Principal

Table of Contents

1.0	INTRODUCTION	1.1
2.0	METHODS.....	2.1
2.1	DATABASE SEARCH.....	2.1
2.2	PLANT COMMUNITY MAPPING AND CLASSIFICATION	2.1
2.3	RARE PLANT AND SITE CHARACTERIZATION SURVEY.....	2.1
2.3.1	Plant Identification	2.2
3.0	RESULTS.....	3.1
3.1	DESKTOP REVIEW.....	3.1
3.2	PLANT COMMUNITIES.....	3.2
3.3	RARE PLANTS.....	3.4
3.4	WEEDS.....	3.6
4.0	REFERENCES.....	4.1

LIST OF TABLES

Table 1	Summary of ACIMS Database Search Results.....	3.1
Table 2	Summary of Plant Community Types within the Study Area	3.4
Table 3	Comprehensive Species List for Surveys within the Study Area	3.7

LIST OF FIGURES

Figure 3-1	Plant Communities	3.5
------------	-------------------	-----

List of Acronyms Occurring Throughout Report

Acronym	Definition
ACIMS	Alberta Conservation Information Management System
AEP	Alberta Environment and Parks
ESRD	Environment and Sustainable Resource Development
TDR	Technical Data Report

1.0 INTRODUCTION

This Vegetation Technical Data Report (TDR) is prepared as supporting information for the Aurum Project (the Project). The TDR outlines the vegetation context for the Study Area including rare plant and rare plant community occurrences and ultimately forms the foundation of the vegetation portion of the Environmental Impact Assessment being submitted in support of the Project.

For this TDR, the Study Area is defined as the quarter-section SE 21-53-23 W4M. Specifically, the Study Area boundaries are the northern extent of SE-21-053-23 W4M, 17 Street NE to the east, 127th Avenue NE to the south and 9 Street NE to the west. This area of 64.59 ha is shown in Figure 3-1 Plant Communities in Section 3.2. This area includes planned potential developments of the Aurum outfall and road crossing as well as potential zones of influence (i.e., areas that may be impacted due to project development).

2.0 METHODS

The following sections describe the methods used to characterize the existing environmental features and conditions within the Study Area based on an aerial photograph interpretation, a desktop review of available environmental information, and a field assessment.

2.1 DATABASE SEARCH

A search of the Alberta Conservation Information Management System (ACIMS) tracking and watch lists was conducted for the entire township which the Study Area is located within. This search was completed to identify known rare plant species and rare ecological community types potentially occurring in the Study Area or adjacent to the Study Area (ACIMS 2016).

2.2 PLANT COMMUNITY MAPPING AND CLASSIFICATION

Plant communities within the Study Area were classified and mapped using the following sources:

- Wheatly and Bentz (2002) for uplands
- Alberta Wetland Classification System (ESRD 2015) for wetlands

Plant communities were identified within the Study Area through review of recent and historic aerial photos. Plant communities were mapped as land units using a geographic information system at a scale of 1:2,500, with a minimum polygon size of 0.04 ha. Land units identified through plant community mapping of the Study Area prior to field surveys were updated based on field data collected during rare plant and site characterization survey (See Section 2.3).

2.3 RARE PLANT AND SITE CHARACTERIZATION SURVEY

The objectives of rare plant and site characterization surveys are to classify the vegetation within the Study Area into land units, and to identify rare plant, rare ecological communities and sensitive environmental conditions as they pertain to vegetation. Additionally, data collected during these surveys can be used to develop appropriate mitigation, conservation, and management recommendations, as required. Rankings for rare plants and rare ecological communities follow Alberta Environment and Parks guidelines (ACIMS 2016).

AURUM PROJECT, SE 21-53-23 W4M

Methods

December 2016

During the rare plant and site characterization survey, information on plant species and ecological communities of management concern, if present, were collected. Species and communities of management concern include:

- Uncommon communities and/or those sensitive to watershed disturbance (e.g. old growth forest, wetlands) identified from upland and wetland class mapping
- Rare plants and rare ecological communities
- *Noxious and prohibited noxious weeds (Weed Control Act [S.A. 2008, c. W-5.1])*

At each survey site GPS coordinates were recorded and representative site photos were taken. Notes on ecological communities or conditions that may require special consideration, if present, were also made.

Vegetation data gathered within the Study Area during the site characterization surveys included percent cover of characteristic tree, shrub, herbaceous, and non-vascular species. Additionally, general site information was recorded, including soil moisture regime, slope and aspect, slope position, and structural stage.

For the rare plant surveys a meander survey protocol was followed and completed within the target plant communities. A comprehensive species list was compiled for each rare plant survey until no new species were found. Specimens requiring further examination or species confirmation were collected, with the exception of plants where seed heads or flowers required for identification to species level were unavailable or where plant populations were small (i.e., no more than 1 in 50 (Alberta Native Plant Council 2006)).

Site characterization and rare plant surveys were conducted at each survey location by a rare plant specialist. These surveys were conducted within the Study Area in two survey intervals to capture different flowering times of plants. These survey intervals correspond to a spring survey and a summer survey (Alberta Native Plant Council 2006). Site characterization and rare plant surveys were conducted on June 30, 2015 (spring survey) and August 28, 2015 (summer survey). For this TDR an additional survey was completed on June 23, 2016 (spring survey) to provide additional data for the anticipated project footprint.

2.3.1 Plant Identification

Collected vascular plant species were identified by a botanist and collected bryophytes were identified by a bryologist. Comprehensive species lists were then referenced to ACIMS tracking and watch lists and SARA (*Species at Risk Act*, S.C. 2002, c. 29) to ensure all plants considered to be rare were identified.

3.0 RESULTS

Section 3.0 discusses the results from desktop review and vegetation surveys.

The Study Area is situated within the Central Parkland Natural Subregion (Central Parkland), which is located within the Parkland Natural Region (Natural Regions Committee 2006). This Subregion is a large transition zone between the Boreal Forest Natural Region to the north and the Grassland Natural Region to the south. The Central Parkland is dominated by undulating till plains and hummocky uplands. Under natural conditions, native vegetation community remnants are a mosaic of aspen (*Populus tremuloides*) dominated forest stands on moist sites intermixed with prairie vegetation on drier sites. Stands of aspen dominated forest are found throughout the Central Parkland and have understories dominated by saskatoon (*Amelanchier alnifolia*), prickly rose (*Rosa acicularis*), and beaked hazelnut (*Corylus cornuta*). Stands dominated by balsam poplar (*Populus balsamifera*) occur on moist, nutrient rich sites, and often have aspen and white spruce (*Picea glauca*) intermixed within the stand (NRC 2006).

The Project is located within a tributary to the North Saskatchewan River Valley which is a provincially significant natural area and a major ecological corridor that traverses the Province of Alberta (City of Edmonton 2008). Provincially significant natural areas can also provide habitat types necessary for rare plants and ecological communities.

3.1 DESKTOP REVIEW

A review of the ACIMS database was completed on June 9th, 2016. No historical occurrences of rare plants or rare communities were identified within the Study Area. One historical observation of Ontario rhodobryum moss (*Rhodobryum ontariense*) was identified within Section 29-52-24 W4M which is now developed into the Edmonton Compost Facility and other industrial developments. This historical observation is summarized in Table 1.

Table 1 Summary of ACIMS Database Search Results

Species	Observation Date	Location	Occurrence within Study Area
<i>Rhodobryum ontariense</i>	October 16, 1973	29-52-24 W4M	No

Ontario Rhodobryum Moss (*Rhodobryum ontariense*).

This moss is listed as *sensitive* under the 2010 Alberta Wild Species General Status listing (ESRD 2012). This species is found on rich soil in and along forest edges, on rotten logs, tree bases, and soil over rock or rock. This is an infrequent species of nutrient rich deciduous forests (Bryophyte Flora of North America).

3.2 PLANT COMMUNITIES

Section 3.2 provides specific details on the plant communities observed within the Study Area including plant assemblage and any unique features.

Six native plant communities were observed during the rare plant and site characterizations. None of the communities observed are listed as rare or sensitive plant communities. Native plant communities that dominate the Study Area are aspen woodland alliance, aspen poplar woodland alliance, and a short shrub alliance (Figure 3-1). The Study Area is bisected by an unnamed Class C waterbody (Alberta Environment 2001), which levels out into a marsh-like area in the north of the Study Area. Most of the Study Area that does not fall into the above-mentioned native plant community classifications is perennial pasture, disturbed (soils and vegetation disturbance), ATCO facility, reclaimed or small inclusions of balsam poplar woodland alliance. The dominant native plant communities are further described below.

The aspen woodland alliance comprises 17.58 ha of the Study Area (27% of the Study Area). This plant community is generally composed of a canopy, dominated by aspen, with a shrub layer dominated by trembling aspen, red-osier dogwood (*Cornus sericea*), prickly rose (*Rosa acicularis*), choke cherry (*Prunus virginiana*) and beaked hazelnut (*Corylus cornuta*). The herbaceous layer is dominated by bluejoint (*Calamagrostis canadensis*), and non-native smooth brome (*Bromus inermis*).

The aspen poplar woodland alliance comprised 1.76 ha of the Study Area (3% of the Study Area). This plant community had a canopy of aspen and balsam poplar. The shrub layer was dominated by high-bush cranberry (*Viburnum opulus*), wild red raspberry (*Rubus idaeus*), pin cherry (*Prunus pensylvanica*) and beaked willow (*Salix bebbiana*). The herbaceous layer was dominated by bluejoint and common nettle (*Urtica dioica*).

A short shrub alliance borders the unnamed Class C waterbody and comprises 1.79 ha of the Study Area (3% of the Study Area). This shrubland is similar to the aspen woodland, but with less of a canopy. The shrubland is dominated by beaked hazelnut, prickly rose, red-osier dogwood, western snowberry (*Symphoricarpos occidentalis*) and shrubby trembling aspen. The ground cover layer is dominated by bluejoint.

The Class C waterbody community comprises 5.47 ha of the Study Area (8% of the Study Area) It was observed that this marsh community displayed vegetative characteristics common to a seasonal marsh. Outside of the channel, the flood plain plant community was dominated by reed canary grass (*Phalaris arundinaceae*), fowl bluegrass (*Poa palustris*) and sedges (*Carex* spp.) occurring sporadically throughout. These plants are all wetland indicator species that would indicate a water adapted plant community.

The following plant community types were not assessed during field surveys but were classified based on historical air photo interpretation.

Four small inclusions of balsam poplar woodland alliance are apparent, comprising 0.71 ha of the Study Area (1.1 % of the Study Area). The canopy of this woodland alliance is composed primarily of balsam poplar, but can also have inclusions of aspen (*Populus tremuloides*), paper birch (*Betula papyrifera*) and sometimes minor spruce components. These communities commonly occur on level areas adjacent to wetlands, lakes, rivers or in low-lying areas or wet and nutrient rich substrates. These sites are typically found on moderately well to imperfectly drained soils, and can be derived from a fluctuating water table or continuous water source (soil is wet for a longer portion of the growing season). This community can also be found at the bottom of slopes or in depressions surrounding more hydrophilic, usually willow-dominated.

A seasonal marsh comprising 0.29 ha of the Study Area (0.5% of the Study Area) was identified in the northeast corner of the Study Area. A soils and vegetation disturbance has occurred within the historical boundaries of the wetland, though the majority of this disturbance is beyond the Study Area. Seasonal marshes are dominated by shallow marsh vegetation in the deepest part of the wetland basin. Shallow marsh vegetation includes moisture-loving grasses and sedges (*Carex* spp.), as well as other species that prefer anoxic conditions.

The disturbed lands included perennial pasture, reclaimed lands, ATCO facilities and soils and vegetation disturbance plant community types. Perennial pasture includes land that is or was used for grazing livestock. Reclaimed lands include land that was previously disturbed, but has since been reclaimed either by natural regeneration or by seed mix. Soils and vegetation disturbance refers to disturbed lands with cleared vegetation and a disturbed soil profile. Lastly, the ATCO Facility classification is referring to a paved area with ATCO facilities and a manicured lawn situated in the southwest corner of the Study Area.

Table 2 summarizes the plant communities occurring with the Study Area, their area and percentage area of the Study Area.

Table 2 Summary of Plant Community Types within the Study Area

Land Unit Type	Community Classification ^{1,2}	Area (ha)	Percent of Study Area (%)
Wetland	Seasonal Marsh ¹	0.29	0.5
Woodland	Aspen woodland alliance ²	17.58	27.2
	Aspen poplar woodland alliance ²	1.76	2.7
	Balsam poplar woodland alliance ²	0.71	1.1
Shrubland	Short shrub alliance ²	1.79	2.8
Watercourse	Unmapped Class C waterbody ³	5.47	8.5
Disturbed	Soils and vegetation disturbance	5.59	8.7
	Perennial Pasture	25.59	39.6
	Reclaimed	4.4	6.8
	Farmstead	1.41	2.2
Total		64.59	100.0
¹ Alberta Wetland Classification System (ESRD 2015) ² Upland Plant Community Type (Wheatley and Bentz 2002) ³ Guide to the Code of Practice for Watercourse Crossings, Including Guidelines for Complying with the Code of Practice (Alberta Environment 2001)			

A comprehensive list of species observed during field surveys completed within the Study Area is provided in Table 3.

3.3 RARE PLANTS

No rare plants were observed in the Study Area during the site characterization and rare plant surveys nor identified through other information sources.



G:\Clients\Aurum Industrial\Aurum Road Outfall\Figures\environmental\impact_assessment\Map_10\Fig_3-1_plantcommunities.mxd Reveled: 2017-01-20 By: jzhu

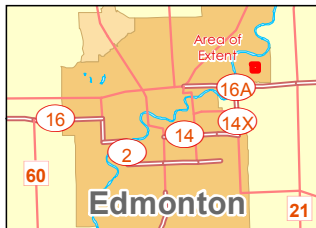



- Notes**
1. Coordinate System: NAD 1983 3TM 114
 2. Base features: Geogratis, ©Department of Natural Resources Canada. All rights reserved.
 3. Imagery: City of Edmonton Transportation, 2015

- Study Area
- Quarter Section
- Wetland**
- Seasonal Marsh (SM)
- Woodland**
- Aspen poplar woodland alliance (AP)
- Aspen woodland alliance (AW)
- Balsam poplar woodland alliance (PB)

- Shrubland**
- Short Shrub Alliance (SS)
- Watercourse**
- Unmapped Class C Waterbody (CC)
- Disturbed**
- ATCO Facility (AF)
- Perennial Pasture (PP)
- Reclaimed (R)
- Soils and Vegetation Disturbance (DL2)

0 100 200 metres
1:5,000 (at original document size of 8.5x11)

Project Location: 12704-17 Street NE, SE/4, 21-053-23 W4M, Edmonton, Alberta
110219671
Prepared by JC on 2016-07-08
Review by MK on 2016-07-11

Client/Project: Aurum Industrial Development Partnership, Aurum Project SE 21-053-23 W4M

Figure No. **3-1**
Title **Plant Communities**

Disclaimer: Stantec assumes no responsibility for data supplied in electronic format. The recipient accepts full responsibility for verifying the accuracy and completeness of the data. The recipient releases Stantec, its officers, employees, consultants and agents, from any and all claims arising in any way from the content or provision of the data.

3.4 WEEDS

Seven species designated as *noxious* in the *Weed Control Regulation* (Alta. Reg. 19/2010) were observed within the Study Area:

- common burdock (*Arctium minus*)
- common tansy (*Tanacetum vulgare*)
- creeping thistle (*Cirsium arvense*)
- field bindweed (*Convolvulus arvensis*)
- great burdock (*Arctium lappa*)
- perennial sow-thistle (*Sonchus arvensis*)
- tall buttercup (*Ranunculus acris*)

Common burdock, common tansy, creeping thistle, field bindweed, great burdock, perennial sow-thistle and tall buttercup were generally found in low densities within the Study Area (occurring at cover percentages of 5% or less within site characterization survey plots). Creeping thistle was observed at cover percentages of 10% at survey points within the unmapped Class C waterbody. A comprehensive list of species observed during the site characterization surveys is provided in Table 3.

Comprehensive Species List			
Scientific Name ¹	Provincial Common Name ²	Weed Designation ³	Plant Form
<i>Dryopteris carthusiana</i>	narrow spinulose shield fern		Fern
<i>Achillea millefolium</i>	common yarrow		Forb
<i>Actaea rubra</i>	red and white baneberry		Forb
<i>Agastache foeniculum</i>	giant hyssop		Forb
<i>Agrimonia striata</i>	agrimony		Forb
<i>Anemone canadensis</i>	Canada anemone		Forb
<i>Antennaria neglecta</i>	broad-leaved everlasting		Forb
<i>Apocynum androsaemifolium</i>	spreading dogbane		Forb
<i>Apocynum cannabinum</i>	Indian hemp		Forb
<i>Aralia nudicaulis</i>	wild sarsaparilla		Forb
<i>Arctium lappa</i>	great burdock	Noxious	Forb
<i>Arctium minus</i>	common burdock	Noxious	Forb
<i>Artemisia absinthium</i>	absinthe wormwood		Forb
<i>Artemisia biennis</i>	biennial sagewort		Forb
<i>Astragalus agrestis</i>	purple milk vetch		Forb
<i>Bidens cernua</i>	nodding beggarticks		Forb
<i>Campanula rotundifolia</i>	harebell		Forb
<i>Capsella bursa-pastoris</i>	shepherd's-purse		Forb
<i>Cerastium arvense</i>	field mouse-ear chickweed		Forb
<i>Chamerion angustifolium ssp. Angustifolium</i>	fireweed		Forb
<i>Cicuta maculata</i>	water-hemlock		Forb
<i>Circaea alpina</i>	small enchanter's nightshade		Forb
<i>Cirsium arvense</i>	creeping thistle	Noxious	Forb
<i>Comandra umbellata</i>	common comandra		Forb
<i>Convolvulus arvensis</i>	field bindweed	Noxious	Forb
<i>Cornus canadensis</i>	bunchberry		Forb
<i>Descurainia sophia</i>	flaxweed		Forb
<i>Epilobium palustre</i>	marsh willowherb		Forb
<i>Equisetum arvense</i>	common horsetail		Forb
<i>Equisetum pratense</i>	meadow horsetail		Forb
<i>Equisetum sylvaticum</i>	woodland horsetail		Forb
<i>Erigeron glabellus</i>	smooth fleabane		Forb
<i>Erigeron philadelphicus</i>	Philadelphia fleabane		Forb
<i>Eurybia conspicua</i>	showy aster		Forb
<i>Fallopia convolvulus</i>	wild buckwheat		Forb
<i>Fragaria vesca</i>	woodland strawberry		Forb
<i>Fragaria virginiana</i>	wild strawberry		Forb
<i>Galearis rotundifolia</i>	round-leaved orchid		Forb
<i>Galeopsis tetrahit</i>	hemp-nettle		Forb
<i>Galium aparine</i>	cleavers		Forb
<i>Galium boreale</i>	northern bedstraw		Forb
<i>Galium trifidum</i>	small bedstraw		Forb
<i>Galium triflorum</i>	sweet-scented bedstraw		Forb
<i>Geum aleppicum</i>	yellow avens		Forb
<i>Geum rivale</i>	purple avens		Forb
<i>Heracleum sphondylium ssp. montanum</i>	cow parsnip		Forb
<i>Hieracium umbellatum</i>	narrow-leaved hawkweed		Forb
<i>Impatiens capensis</i>	spotted touch-me-not		Forb
<i>Lemna minor</i>	common duckweed		Forb
<i>Leucanthemum vulgare</i>	ox-eye daisy		Forb
<i>Lycopus uniflorus</i>	northern water-horehound		Forb
<i>Lysimachia ciliata</i>	fringed loosestrife		Forb
<i>Lysimachia remyi ssp. remyi</i>	yellow loosestrife		Forb
<i>Lysimachia thyrsoiflora</i>	tufted loosestrife		Forb
<i>Maianthemum canadense</i>	wild lily-of-the-valley		Forb
<i>Maianthemum stellatum</i>	star-flowered Solomon's-seal		Forb
<i>Melilotus albus</i>	white sweet-clover		Forb
<i>Melilotus officinalis</i>	yellow sweet-clover		Forb
<i>Mentha arvensis</i>	wild mint		Forb
<i>Mentha arvensis</i>	wild mint		Forb
<i>Mertensia paniculata</i>	tall lungwort		Forb
<i>Mitella nuda</i>	bishop's-cap		Forb
<i>Persicaria amphibia</i>	water knotweed		Forb
<i>Petasites frigidus var. palmatus</i>	palmate-leaved coltsfoot		Forb
<i>Petasites frigidus var. sagittatus</i>	arrow-leaved coltsfoot		Forb
<i>Plantago major</i>	common plantain		Forb
<i>Prosartes trachycarpa</i>	fairybells		Forb
<i>Prosartes trachycarpa</i>	rough-fruit fairybells		Forb
<i>Pyrola asarifolia</i>	common pink wintergreen		Forb
<i>Ranunculus acris</i>	tall buttercup	Noxious	Forb
<i>Ranunculus sceleratus</i>	celery-leaved buttercup		Forb
<i>Rorippa islandica</i>	northern marsh yellowcress		Forb
<i>Rubus pubescens</i>	dewberry		Forb
<i>Rumex sp.</i>	dock		Forb
<i>Rumex maritimus</i>	golden dock		Forb
<i>Rumex salicifolius</i>	willow dock		Forb
<i>Sanicula marilandica</i>	snakeroot		Forb
<i>Senecio vulgaris</i>	common groundsel		Forb
<i>Solidago caesia var. caesia</i>	wreath goldenrod		Forb
<i>Solidago canadensis</i>	Canada goldenrod		Forb
<i>Sonchus arvensis</i>	perennial sow-thistle	Noxious	Forb
<i>Stachys palustris</i>	marsh hedge-nettle		Forb
<i>Stellaria calycantha</i>	northern stitchwort		Forb
<i>Symphotrichum boreale</i>	marsh aster		Forb
<i>Symphotrichum ciliatum</i>	rayless aster		Forb
<i>Symphotrichum ciliolatum</i>	Lindley's aster		Forb
<i>Symphotrichum puniceum</i>	purple-stemmed aster		Forb
<i>Tanacetum vulgare</i>	common tansy	Noxious	Forb
<i>Taraxacum officinale</i>	common dandelion		Forb
<i>Thalictrum venulosum</i>	veiny meadow rue		Forb
<i>Trifolium hybridum</i>	alsike clover		Forb
<i>Trifolium pratense</i>	red clover		Forb
<i>Typha latifolia</i>	common cattail		Forb
<i>Urtica dioica</i>	common nettle		Forb
<i>Veronica americana</i>	American brooklime		Forb
<i>Vicia americana</i>	wild vetch		Forb
<i>Viola canadensis</i>	western Canada violet		Forb
<i>Viola palustris</i>	marsh violet		Forb
<i>Viola renifolia</i>	kidney-leaved violet		Forb

Scientific Name ¹	Provincial Common Name ²	Weed Designation ³	Plant Form
<i>Agrostis scabra</i>	rough hair grass		Graminoid
<i>Alopecurus aequalis</i>	short-awned foxtail		Graminoid
<i>Beckmannia syzigachne</i>	slough grass		Graminoid
<i>Bolboschoenus maritimus</i> ssp. <i>Paludosus</i>	alkali bulrush		Graminoid
<i>Bromus ciliatus</i>	fringed brome		Graminoid
<i>Bromus inermis</i>	smooth brome		Graminoid
<i>Calamagrostis canadensis</i>	bluejoint		Graminoid
<i>Calamagrostis stricta</i> ssp. <i>inexpansa</i>	northern reedgrass		Graminoid
<i>Carex aquatilis</i>	water sedge		Graminoid
<i>Carex atherodes</i>	awned sedge		Graminoid
<i>Carex bebbii</i>	Bebb's sedge		Graminoid
<i>Carex concinna</i>	beautiful sedge		Graminoid
<i>Carex crawfordii</i>	Crawford's sedge		Graminoid
<i>Carex deweyana</i>	Dewey's sedge		Graminoid
<i>Carex disperma</i>	two-seeded sedge		Graminoid
<i>Carex foenea</i>	silvery-flowered sedge		Graminoid
<i>Carex vaginata</i>	sheathed sedge		Graminoid
<i>Dactylis glomerata</i>	orchard grass		Graminoid
<i>Elymus trachycaulus</i>	slender wheatgrass		Graminoid
<i>Glyceria grandis</i>	common tall manna grass		Graminoid
<i>Glyceria striata</i>	fowl manna grass		Graminoid
<i>Hordeum jubatum</i>	foxtail barley		Graminoid
<i>Nassella viridula</i>	green needle grass		Graminoid
<i>Oryzopsis</i> sp.	rice grass		Graminoid
<i>Oryzopsis asperifolia</i>	white-grained mountain rice grass		Graminoid
<i>Phalaris arundinacea</i>	reed canary grass		Graminoid
<i>Phleum pratense</i>	timothy		Graminoid
<i>Phragmites australis</i>	common reed		Graminoid
<i>Poa palustris</i>	fowl bluegrass		Graminoid
<i>Poa pratensis</i>	Kentucky bluegrass		Graminoid
<i>Scirpus microcarpus</i>	small-fruited bulrush		Graminoid
<i>Ptilidium pulcherrimum</i>	liverwort		Liverwort
<i>Plagiomnium ellipticum</i>	moss		Moss
<i>Pylaisiella polyantha</i>	moss		Moss
<i>Sanionia uncinata</i>	brown moss		Moss
<i>Alnus incana</i> ssp. <i>Rugosa</i>	speckled alder		Shrub
<i>Alnus viridis</i>	green alder		Shrub
<i>Amelanchier alnifolia</i>	saskatoon		Shrub
<i>Cornus sericea</i>	redosier dogwood		Shrub
<i>Cornus sericea</i> ssp. <i>Sericea</i>	red-osier dogwood		Shrub
<i>Corylus cornuta</i>	beaked hazelnut		Shrub
<i>Lonicera dioica</i>	twining honeysuckle		Shrub
<i>Lonicera involucrata</i>	bracted honeysuckle		Shrub
<i>Prunus pennsylvanica</i>	pin cherry		Shrub
<i>Prunus virginiana</i>	choke cherry		Shrub
<i>Rhamnus alnifolia</i>	alder-leaved buckthorn		Shrub
<i>Ribes americanum</i>	wild black currant		Shrub
<i>Ribes hudsonianum</i>	northern black currant		Shrub
<i>Ribes oxycanthoides</i>	northern gooseberry		Shrub
<i>Ribes triste</i>	wild red currant		Shrub
<i>Rosa acicularis</i>	prickly rose		Shrub
<i>Rubus idaeus</i>	wild red raspberry		Shrub
<i>Salix bebbiana</i>	beaked willow		Shrub
<i>Symphoricarpos albus</i>	snowberry		Shrub
<i>Symphoricarpos occidentalis</i>	buckbrush		Shrub
<i>Vaccinium myrtilloides</i>	common blueberry		Shrub
<i>Viburnum edule</i>	low-bush cranberry		Shrub
<i>Viburnum opulus</i>	high-bush cranberry		Shrub
<i>Acer negundo</i>	Manitoba maple		Tree
<i>Betula papyrifera</i>	white birch		Tree
<i>Populus balsamifera</i>	balsam poplar		Tree
<i>Populus tremuloides</i>	aspen		Tree
<i>Salix maccalliana</i>	velvet-fruited willow		Tree
<i>Sorbus scopulina</i>	western mountain-ash		Tree

¹Integrated Taxonomic Information System (ITIS). 2016.

²Alberta Conservation Information Management System (ACIMS). 2016

³Weed Control Regulation (Alta. Reg. 19/2010)

4.0 REFERENCES

Alberta Conservation Information Management System (ACIMS). 2016. *Alberta Conservation Information Management System (ACIMS)*. Accessed June 2016.

<http://www.albertaparks.ca/albertaparksca/management-land-use/alberta-conservation-information-management-system-acims/>

Alberta Environment. 2001. *Guide to the Code of Practice for Watercourse Crossings, Including Guidelines for Complying with the Code of Practice*. Accessed July 2016.

<<http://esrd.alberta.ca/water/legislation-guidelines/documents/WatercourseCrossingsGuide-Apr2001.pdf>>

Alberta Environment and Sustainable Resource Development (ESRD). 2012. *Wild species status search*. Accessed June 2016. <<http://esrd.alberta.ca/fish-wildlife/species-at-risk/alberta-species-at-risk-strategy/general-status-of-alberta-wild-species-2010/documents/SAR-2010WildSpeciesGeneralStatusList-Jan2012.pdf>>

Alberta Native Plant Council. 2006. Plant collection guidelines for researchers, students and consultants. Accessed March 2016. < http://anpc.ab.ca/wp-content/uploads/2015/01/researchers_students.pdf>

Bryophyte Flora of North America. eFloras.org. Accessed June 2016.

<http://www.efloras.org/florataxon.aspx?flora_id=50&taxon_id=250062096>

City of Edmonton. 2008. *Biodiversity report*. City of Edmonton. Edmonton.

ESRD. 2015. *Alberta Wetland Classification System*. Water Policy Branch, Policy and Planning Division, Edmonton.

Integrated Taxonomic Information System (ITIS). 2016. *Integrated Taxonomic Information System*. Accessed March 2016. <www.itis.gov>

Natural Regions Committee (NRC). 2006. *Natural regions and subregions of Alberta*. Compiled by D.J. Downing and W.W. Pettapiece. Government of Alberta. Edmonton.

Species at Risk Act. S.C. 2002, c. 29.

Weed Control Act. S.A. 2008, c. W-5.1.

Weed Control Regulation. Alta. Reg. 19/2010.

Wheatley, M. and J. Bentz. 2002. *A Preliminary Classification of Plant Communities in the Central Parkland Natural Subregion of Alberta*. Alberta Sustainable Resource Development, Public Lands Division, Resource Data Branch, Edmonton

APPENDIX C
WILDLIFE TECHNICAL DATA REPORT

**Aurum Project,
SE 21-53-23 W4M**

Technical Data Report
Wildlife



Prepared for:
Aurum Industrial Development
Partnership

Prepared by:
Stantec Consulting Ltd
Edmonton, Alberta

December 2016
110219671

Sign-off Sheet

This document entitled Aurum Project, SE 21-53-23 W4M was prepared by Stantec Consulting Ltd. ("Stantec") for the account of Aurum Industrial Development Partnership (the "Client"). Any reliance on this document by any third party is strictly prohibited. The material in it reflects Stantec's professional judgment in light of the scope, schedule and other limitations stated in the document and in the contract between Stantec and the Client. The opinions in the document are based on conditions and information existing at the time the document was published and do not take into account any subsequent changes. In preparing the document, Stantec did not verify information supplied to it by others. Any use which a third party makes of this document is the responsibility of such third party. Such third party agrees that Stantec shall not be responsible for costs or damages of any kind, if any, suffered by it or any other third party as a result of decisions made or actions taken based on this document.



Prepared by _____
(signature)

Stephanie Grossman, M.Sc., P. Biol.
Wildlife Biologist



Reviewed by _____
(signature)

Stephanie Grossman, M.Sc., P.Biol.
Wildlife Biologist

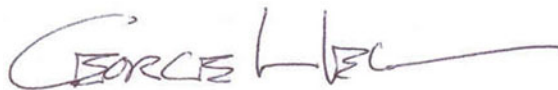

Approved by _____
(signature)

George Hegmann, B.Eng., M.E.Des., P.Eng.
Senior Principal

Sign-off Sheet

Table of Contents

ABBREVIATIONS	ii
1.0 INTRODUCTION	1.1
1.1 SPATIAL BOUNDARIES	1.1
2.0 METHODS	2.1
2.1 DESKTOP STUDY	2.1
2.2 FIELD STUDIES	2.1
2.2.1 Amphibian Survey	2.1
2.2.2 Breeding Bird Survey.....	2.1
3.0 RESULTS	3.1
3.1 DESKTOP STUDY	3.1
3.1.1 Amphibians and Reptiles.....	3.1
3.1.2 Birds.....	3.1
3.1.3 Mammals.....	3.2
3.1.4 Species of Management Concern.....	3.3
3.2 FIELD STUDIES	3.5
3.2.1 Amphibian Survey	3.5
3.2.2 Breeding Bird Survey.....	3.5
4.0 REFERENCES	4.1
LIST OF TABLES	
Table 3-1 Species of Management Concern Previously Detected Within a 2 km Radius of the Study Area.....	3.4
Table 3-2 Birds Detected in the Study Area	3.5
LIST OF FIGURES	
Figure 1-1 Wildlife Study Area.....	1.2

Abbreviations

AEP	Alberta Environment and Parks
ESRD	Alberta Environment and Sustainable Resource Development
km	kilometer
KWBZ	Key Wildlife Biodiversity Zone
m	meter
NSR	North Saskatchewan River
SAR	Species at Risk
SOMC	Species of Management Concern
TDR	Technical Data Report
VC	Valued Component

1.0 INTRODUCTION

This Wildlife Technical Data Report (TDR) is prepared as supporting information for the Aurum road and outfall project (the Project). The purpose of this TDR is to describe the existing conditions of wildlife and wildlife habitat in the vicinity of the Project, including the methods used to collect this information.

The wildlife and wildlife habitat valued component (VC) represents a broad range of taxonomic groups that are known to occur or have potential to occur in the Study Area (see Section 1.1) including amphibians, reptiles, birds, and mammals. Species of management concern (SOMC) are also identified, including both federal and provincial species at risk (SAR) as well as other wildlife species that are recognized in federal or provincial guidelines.

1.1 SPATIAL BOUNDARIES

The Study Area for the characterization of existing conditions for wildlife is limited by the quarter section boundary for SE-21-053-23-W4M (Figure 1-1). This area includes planned potential developments of the Aurum outfall and road crossing as well as potential zones of influence (i.e., area of reduced use or avoidance).

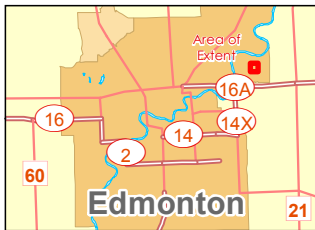

- Notes**
1. Coordinate System: NAD 1983 3TM 114
 2. Base features: Geogratis, ©Department of Natural Resources Canada. All rights reserved.
 3. Imagery: City of Edmonton Transportation, 2015

Disclaimer: Stantec assumes no responsibility for data supplied in electronic format. The recipient accepts full responsibility for verifying the accuracy and completeness of the data. The recipient releases Stantec, its officers, employees, consultants and agents, from any and all claims arising in any way from the content or provision of the data.

- Study Area
- Quarter Section
- Survey Points**
- ◆ Amphibian
- ◆ Bird
- Wetland**
- Seasonal Marsh (SM)
- Woodland**
- Aspen poplar woodland alliance (AP)
- Aspen woodland alliance (AW)
- Balsam poplar woodland alliance (PB)
- Shrubland**
- Short Shrub Alliance (SS)
- Watercourse**
- Unmapped Class C Waterbody (CC)
- Disturbed**
- ATCO Facility (AF)
- Perennial Pasture (PP)
- Reclaimed (R)
- Soils and Vegetation Disturbance (DL2)

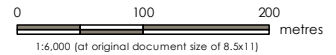

Project Location
12704-17 Street NE
SE 21-053-23 W 4M
Edmonton, Alberta

110219671
Prepared by JC on 2016-07-08
Review by MK on 2016-07-11

Client/Project
Aurum Industrial Development
Aurum Project SE 21-053-23 W4M

Figure No.
1-1

Title
Wildlife Study Area and Survey Points

2.0 METHODS

The following sections describe the methods used to document the existing conditions within the Study Area.

2.1 DESKTOP STUDY

Relevant information pertaining to the Study Area for wildlife was reviewed and summarized as part of the desktop study. Information sources that were reviewed included scientific journals, publicly available reports, internet sites, and online databases (see Section 3.1). Previous work in was conducted by Spencer (2014) and AMEC Foster Wheeler on mammal use and movements in the Study Area and these were reviewed for information on mammals (see Section 3.1.3).

2.2 FIELD STUDIES

Nocturnal acoustic amphibian surveys and breeding bird surveys were conducted to document the existing condition of wildlife in the Study Area. Information on mammal use of the Study Area is taken from existing information reviewed in the desktop study. The field methods used are described in the following sub-sections.

2.2.1 Amphibian Survey

Amphibian surveys were conducted in and adjacent to the Study Area on May 26, June 4, and June 10, 2015 at three locations (Figure 1-1) from 30 minutes after sunset to no later than 2:00 AM. Surveys were conducted three times within the amphibian breeding season (mid-April through end of June) as recommended by Alberta Environment and Parks (AEP) (ESRD 2013) guidelines. The amphibian surveys consisted of a two-minute period of silence to reduce disturbance effects associated with the arrival of observers, followed by a five-minute listening period where all amphibian species detected were recorded. The amphibian survey was conducted at wind speeds below 20 km/h (i.e., Beaufort 3) and conditions not exceeding a light rain to optimize the ability of observers to effectively hear all amphibians vocalizing. The abundance of amphibians was recorded using the abundance index as described in ESRD (2013). Incidental wildlife species and signs of wildlife (e.g. scat, trails) encountered during the amphibian survey were also recorded.

2.2.2 Breeding Bird Survey

Breeding bird surveys were conducted in the Study Area on June 11 and 19, 2015 at four locations (Figure 1-1) between sunrise and 10:00 a.m. during the peak breeding period for migratory songbirds (June 1st through July 7th) as recommended by AEP (ESRD 2013). A modified fixed-radius point count sampling survey procedure (Bibby et al. 1993) was used to document bird species. The breeding bird survey consisted of a two-minute period of silence to reduce disturbance effects associated with the arrival of observers followed by a 10-minute listening

AURUM PROJECT, SE 21-53-23 W4M

Methods

December 2016

periods where all birds heard vocalizing or observed within 100 m of the point were recorded. Surveys were conducted twice within the breeding bird season. The breeding bird surveys were conducted at wind speeds below 20 km/h (i.e. Beaufort 3) and conditions not exceeding a light rain, as these conditions are when bird activity is highest and optimize the ability of observers to effectively detect birds. Incidental observations of birds detected outside the 100 m point count radius during the survey were also recorded as incidentals and were included in the species list of birds observed.

3.0 RESULTS

The following sections summarize the results of the desktop and field studies, and provide an understanding of the existing wildlife conditions in the Study Area.

3.1 DESKTOP STUDY

The findings of the desktop study are described in the following sub-sections.

The Study Area is located in the North Saskatchewan River (NSR) valley and ravine system. Prior biophysical studies conducted in this area (e.g., EPEC 1981, Strong and MacCallum 1984, Strong et al. 1985) have suggested that the NSR valley and ravine system supports a large diversity of species as a result of the wide range of habitats available. The young aspen forest and shrub communities provide habitat for several small shrub and forb-dependent wildlife species; while the mature forest stands provide foraging, breeding and shelter habitat for other wildlife species.

The City of Edmonton (2008) lists 225 species that may occur within the Study Area. These species include 178 birds, 47 mammals, and seven herptiles. Twenty percent (i.e., 46 species) of the 225 species that may occur in the Study Area are listed as SOMC either federally and/or provincially (City of Edmonton 2008).

3.1.1 Amphibians and Reptiles

Amphibians and reptiles represent less than five percent of species that have the potential to occur in the Study Area (City of Edmonton 2008). Common amphibians and reptiles that may be found within Edmonton consist of wood frog (*Lithobates sylvatica*), boreal chorus frog (*Pseudacris maculata*), and red-sided garter snake (*Thamnophis sirtalis*) (City of Edmonton 2008). Wood frog was detected in the Study Area by Stantec (2008) and AMEC Foster Wheeler (2015) identified suitable habitat for the amphibians in the Study Area. Less common species such as tiger salamander (*Ambystoma tigrinum*), plains garter snake (*Thamnophis radix*), Canadian toad (*Anaxyrus hemiophrys*), and western toad (*Anaxyrus boreas*) also occur within Edmonton. Western toads have been recorded around Big Lake in the northwest corner of Edmonton (AMEC EEL 2002, Stantec 2007), while Canadian toads have been recorded in the Clover Bar waste management area in early 2000 and from Terwillegar park in 2004, 2005 and 2013 (Browne 2009, Stantec 2014a).

3.1.2 Birds

Although the total number of bird species varies in the literature, it is estimated that birds represent approximately 80 percent of wildlife species that may occur in the Study Area. According to the City of Edmonton (2008), 178 bird species occur within Edmonton. Spencer (1976) recorded 73 bird species in four ravines in the NSR valley and ravine system in 1972 and 1973, and EPEC (1981) estimated that 150 bird species occur within the NSR valley and ravine

system. However, a large number of these species are neo-tropical migrants and are only present during the breeding season.

A wide range of habitats are available for birds within Edmonton; however, Strong and MacCallum (1984) observed a preference for the mixedwood habitats associated with ravines for breeding species, while deciduous habitats were preferred by wintering birds. The Edmonton Christmas Bird Count conducted in December 2015 recorded 55 bird species, mostly year-round residents or species in their wintering range (National Audubon Society [NAS] 2016).

Two pre-disturbance nest surveys in advance of grading activities to widen 17 Street were conducted in the Study Area on June 16 and July 18, 2014. Eleven bird species were detected during these two surveys: alder flycatcher (*Empidonax alnorum*), American crow (*Corvus brachyrhynchos*), American robin (*Turdus migratorius*), black-billed magpie (*Pica hudsonica*), cedar waxwing (*Bombycilla cedrorum*), clay-colored sparrow (*Spizella pallida*), house wren (*Troglodytes aedon*), savannah sparrow (*Passerculus sandwichensis*), spotted sandpiper (*Actitis macularius*), song sparrow (*Melospiza melodia*) and yellow warbler (*Setophaga petchia*). Four active clay-colored sparrow nests and one active house wren nest were found in the Study Area (Stantec 2014b). Black-billed magpie and common raven (*Corvus corax*) were also detected in the Study Area by Spencer (2014).

3.1.3 Mammals

Mammals represent approximately 20 percent of species that may occur in the Study Area (City of Edmonton 2008). Small mammals common in the Greater Edmonton area include beaver (*Castor canadensis*), muskrat (*Ondatra zibethica*), snowshoe hare (*Lepus americanus*), Franklin's ground squirrel (*Citellus franklinii*), northern flying squirrel (*Glaucomys sabrinus*), porcupine (*Erethizon dorsatum*), red squirrel (*Tamiasciurus hudsonicus*), skunk (*Mephitis mephitis*), white-tailed jack rabbit (*Lepus townsendii*), deer mice (*Peromyscus maniculatus*), red backed vole (*Microtus microtus*), shrews (Family *Soricidae*), western jumping mice (*Zapus princeps*), house mouse (*Mus musculus*), and big brown bat (*Eptesicus fuscus*) (EPEC 1981; City of Edmonton 2008).

Some larger mammals such as white-tailed deer (*Odocoileus virginianus*), mule deer (*Odocoileus hemionus*), moose (*Alces alces*), coyote (*Canis latrans*), and red fox (*Vulpes vulpes*) are also commonly observed in the NSR valley and ravine system. Other large mammals including black bear (*Ursus americanus*), Canada lynx (*Lynx canadensis*), and cougar (*Puma concolor*) may also be observed occasionally within the Study Area because the NSR valley and ravine system is part of a large ecological corridor that provides connectivity across the province that may be used by these large mammals (EPEC 1981).

Spencer (2014) conducted a wildlife movement study in the Study Area. Six mammal species were detected during this study using remote cameras and during winter tracking surveys: coyote, white-tailed deer, porcupine, red squirrel, snowshoe hare and weasel (Spencer 2014). Coyote and white-tailed deer were the most common species detected. The study concluded

Results
December 2016

that Clover Bar ravine in the Study Area provides core habitat for at least two coyote individuals and provides shelter and foraging habitat for white-tailed deer. According to Spencer (2014), Clover Bar ravine provides connectivity between the NSR and natural areas south of the Study Area.

AMEC Foster Wheeler (2015) estimated that almost 100% of the Study Area was potentially suitable habitat for white-tailed deer and that forested portions of the Study Area were potentially suitable for snowshoe hare. They also reported 96 wildlife collisions on the Yellowhead, south of the Study Area, between 2008 and 2012 involving mostly white-tailed deer but also moose, white-tailed jackrabbit and a raccoon (*Procyon lotor*); suggesting that these species may be found in the Study Area. The study concluded that the Clover Bar ravine provides poor connectivity between the NSR and other natural areas. The Clover Bar ravine intersects with multiple roads and a railways and ends on Highway 16.

3.1.4 Species of Management Concern

A search was performed within Fish and Wildlife Management Information System (FWMIS) to obtain information on SOMC and wildlife sensitivity layers occurring in the Study Area. The FWMIS database search confirmed the occurrence of 10 bird and two amphibian SOMC within 2 km of the Study Area boundary (AEP 2016). See Table 3-1 for details on SOMC and their potential to occur in the Study Area.

The Study Area is located in the provincially designated a Sensitive Raptor Range for bald eagle and Sharp-tailed Grouse Survey Area (AEP 2016). While the Study Area is within the identified range for sharp-tailed grouse, it is unlikely that this species would occur here because the open prairie habitat it is associated with (Connelly et al. 1998) is not available within the Study Area. It is possible that bald eagles utilize the Study Area as they are known for nesting near water bodies due to their reliance on fish as a food source (Buehler 2000).

A Key Wildlife Biodiversity Zone (KWBZ) associated with the North Saskatchewan River and its tributaries extends into the northeast corner of the Study Area. KWBZs are sensitive areas identified by AEP as having high biodiversity potential and/or being key ungulate winter habitat. Major river valleys, where KWBZ are typically located, provide the necessary topographic variability and productivity to support high biodiversity and abundant winter browse for ungulates (ESRD 2015).

AURUM PROJECT, SE 21-53-23 W4M

Results
December 2016

Table 3-1 Species of Management Concern Previously Detected Within a 2 km Radius of the Study Area

Species			Conservation Status			Potential to Occur in the Study Area
Family	Scientific Name	Common Name	Alberta Wild Species Rank ¹	Wildlife Act ²	SARA ³	
<i>Bufo</i>	<i>Anaxyrus hemiophrys</i>	Canadian toad	<i>may be at risk</i>	N/A	<i>special concern</i>	May occur in the Study Area
<i>Rana</i>	<i>Lithobates pipiens</i>	northern leopard frog	<i>at risk</i>	<i>threatened</i>	<i>special concern</i>	Previously detected in the region but outside of the current range of this species ⁴
<i>Anas</i>	<i>Anas crecca</i>	green-winged teal	<i>sensitive</i>	N/A	N/A	May occur in the Study Area
<i>Anas</i>	<i>Aythya affinis</i>	lesser scaup	<i>sensitive</i>	N/A	N/A	May occur in the Study Area
<i>Ardea</i>	<i>Ardea herodias</i>	great blue heron	<i>sensitive</i>	N/A	N/A	Not likely to occur in the Study Area
<i>Buteo</i>	<i>Buteo swainsoni</i>	Swainson's hawk	<i>sensitive</i>	N/A	N/A	May occur in the Study Area
<i>Icterus</i>	<i>Icterus galbula</i>	Baltimore oriole	<i>sensitive</i>	N/A	N/A	May occur in the Study Area
<i>Falco</i>	<i>Falco peregrinus anatum</i>	peregrine falcon	<i>at risk</i>	<i>threatened</i>	<i>special concern</i>	No breeding habitat is present for this species in the Study Area; however, they may forage in open areas in the Study Area
<i>Pandion</i>	<i>Pandion haliaetus</i>	osprey	<i>sensitive</i>	N/A	N/A	No suitable habitat for this species in the Study Area
<i>Rallus</i>	<i>Porzana carolina</i>	sora	<i>sensitive</i>	N/A	N/A	May occur in the Study Area
<i>Tyrannus</i>	<i>Empidonax minimus</i>	least flycatcher	<i>sensitive</i>	N/A	N/A	May occur in the Study Area
<i>Tyrannus</i>	<i>Sayornis phoebe</i>	eastern phoebe	<i>sensitive</i>	N/A	N/A	May occur in the Study Area
NOTES: ¹ ESRD 2012; ² ESRD 2014; ³ Government of Canada 2015; ⁴ ESRD 2003						



3.2 FIELD STUDIES

The findings of the nocturnal acoustic amphibian survey and breeding bird survey are described in the following sub-sections.

3.2.1 Amphibian Survey

Boreal chorus frog was detected at AMPH1 (see Figure 1-1). Boreal chorus frogs are not a listed or ranked species, provincially or federally.

Two wildlife trails and six white-tailed deer were observed incidentally during the amphibian survey.

3.2.2 Breeding Bird Survey

Twenty-eight bird species were detected; four of the species detected are SOMC (listed as *sensitive* in Alberta): barn swallow, least flycatcher, osprey and western-wood pewee (Table 3-2). The remainder of the bird species detected is commonly-occurring, urban-adapted species that typically do well in small habitat patches or in edge habitat. It is assumed that any of the species present could be using the Study Area for breeding. Direct evidence of breeding of song sparrow and house wren was observed during the breeding bird survey. A beaver and a white-tailed deer were observed incidentally during breeding bird surveys.

Table 3-2 Birds Detected in the Study Area

Common Name	Scientific Name	Alberta Wild Species Rank ¹	Wildlife Act ²	SARA ³
American crow	<i>Corvus brachyrhynchos</i>	secure	N/A	N/A
American goldfinch	<i>Spinus tristis</i>	secure	N/A	N/A
American robin	<i>Turdus migratorius</i>	secure	N/A	N/A
barn swallow	<i>Hirundo rustica</i>	sensitive	N/A	N/A
black-billed magpie	<i>Pica hudsonia</i>	secure	N/A	N/A
black-capped chickadee	<i>Poecile atricapillus</i>	secure	N/A	N/A
brown-headed cowbird	<i>Molothrus ater</i>	secure	N/A	N/A
cedar waxwing	<i>Bombycilla cedrorum</i>	secure	N/A	N/A
cinnamon teal	<i>Anas cyanoptera</i>	secure	N/A	N/A
clay-colored sparrow	<i>Spizella pallida</i>	secure	N/A	N/A
house wren	<i>Troglodytes aedon</i>	secure	N/A	N/A
killdeer	<i>Charadrius vociferus</i>	secure	N/A	N/A
least flycatcher	<i>Empidonax minimus</i>	sensitive	N/A	N/A
mallard	<i>Anas platyrhynchos</i>	secure	N/A	N/A
orange-crowned warbler	<i>Vermivora celata</i>	secure	N/A	N/A

Results
December 2016

Common Name	Scientific Name	Alberta Wild Species Rank ¹	Wildlife Act ²	SARA ³
osprey	<i>Pandion haliaetus</i>	sensitive	N/A	N/A
red-eyed vireo	<i>Vireo olivaceus</i>	secure	N/A	N/A
red-tailed hawk	<i>Buteo jamaicensis</i>	secure	N/A	N/A
red-winged blackbird	<i>Agelaius phoeniceus</i>	secure	N/A	N/A
savannah sparrow	<i>Passerculus sandwichensis</i>	secure	N/A	N/A
song sparrow	<i>Melospiza melodia</i>	secure	N/A	N/A
spotted sandpiper	<i>Actitis macularius</i>	secure	N/A	N/A
Tennessee warbler	<i>Vermivora peregrina</i>	secure	N/A	N/A
tree swallow	<i>Tachycineta bicolor</i>	secure	N/A	N/A
vesper sparrow	<i>Pooecetes gramineus</i>	secure	N/A	N/A
western-wood pewee	<i>Contopus sordidulus</i>	sensitive	N/A	N/A
white-throated sparrow	<i>Zonotrichia albicollis</i>	secure	N/A	N/A
yellow warbler	<i>Setophaga petichia</i>	secure	N/A	N/A
Notes: ¹ ESRD (2012) ² ESRD (2014) ³ Government of Canada (2015)				

SOMC observed in the Study Area are discussed below.

3.2.2.1 barn swallow

In Alberta, barn swallow is found in every Natural Region (FAN 2007) near water courses or in open areas such as agricultural land where the species can forage on flying insects (Brown and Bomberger Brown 1999). Nesting usually occurs near anthropogenic areas where mud nests are constructed on built structures. Nesting in natural sites such as caves may occur but is uncommon. Nests are constructed on horizontal or vertical surfaces or rafters of buildings, barns, and under bridges. Mating pairs will often nest in the same area from year to year, refurbishing the same nest if possible (Brown and Bomberger Brown 1999).

Barn swallows are listed as *sensitive* by AEP (ESRD 2012). In Alberta, the species' relative abundance has decreased between the late 1980s to early 2000s (FAN 2007) and declines of 5.1%/year have been documented from breeding bird survey data (COSEWIC 2011). These declines are thought to be associated with a number of factors, including habitat loss due to the shift in agricultural practices, resulting in a reduced availability of nesting structures. Declines in insect populations and climate change are also thought to have played a role in the species declines (COSEWIC 2011). Suitable habitat, including open areas with abundant insects, is available for this species in the Study Area.

3.2.2.2 least flycatcher

The least flycatcher is found in all ten Canadian provinces and two territories (Yukon and Northwest Territories). Least flycatchers are primarily found in deciduous or mixedwood forests and commonly observed in the vicinity of open areas (e.g., forest clearings), water (e.g., swamps or lakes) and roads. The species builds grass nest cups in trees and start nesting in May after they return from migration. They feed mostly on flying insects and insects located in the foliage of trees (Tarof and Briskie 2008).

Although reportedly common, populations of this species have declined west of the Province of Ontario since the late 1960s. Their decline appears concealed by the fact that the species is still observed on a regular basis. The relative abundance of least flycatcher declined in Alberta between the late 1980s and the beginning of the early 2000s (FAN 2007). FAN (2007) has suggested the cause of their decline could be located outside of Alberta. Currently, the least flycatcher is listed as *sensitive* by AEP (ESRD 2012).

3.2.2.3 osprey

Osprey is widespread and breeds in most of Canada, except Nunavut. The species nests in the vicinity of large water bodies such as lakes and rivers because it relies heavily on fish as a food source. Nesting occurs in open areas on large stick nests in trees, artificial nest platforms, cliffs or on the ground on islands where predators are absent (Poole et al. 2002). The breeding season starts in late April in Alberta (FAN 2007).

Ospreys are listed as *sensitive* by AEP (ESRD 2012). Breeding bird survey data have reported stable population numbers in Alberta and increases in Canada between the late 1960s and mid-2000s. During the last Alberta breeding bird atlas, increases have been documented in the Boreal Forest, Grassland, Parkland and Rocky Mountain NR. The species' listing is due to multiple threats to its habitat and overall small population in the province.

3.2.2.4 western-wood pewee

The western wood-pewee mainly breeds in coniferous forests, but also occasionally in deciduous woodlands and in trees along watercourses. Nesting occurs and trees and the species forages on flying insects (Bemis and Rising 1999). Breeding season typically begins in early June in its northern range (Baicich and Harrison 2005).

Western wood-pewees are listed as *sensitive* by AEP (ESRD 2012). Destruction of habitat on the species range is considered main a threat (Bemis and Rising 1999).

4.0 REFERENCES

- Alberta Environment and Parks (AEP). 2016. Access FWMIS data. Accessed May 2016.
<<http://esrd.alberta.ca/fish-wildlife/fwmis/access-fwmis-data.aspx>>
- AMEC Earth and Environmental Limited (AMEC EEL). 2002. *Big Lake Natural Area Management Plan: Phase I Report*. Report prepared by AMEC Earth and Environmental in association with Richard Thomas, EDA Collaborative Inc. for Alberta Community Development Parks and Protected Areas Division. Lac La Biche.
- AMEC Foster Wheeler Environment and Infrastructure (AMEC Foster Wheeler). 2015. 17 Street NE Clover Bar Ravine Wildlife Passage Study. Prepare for the City of Edmonton, Edmonton, Alberta.
- Baicich, P. and Harrison, C. 2005. *Nests, Eggs, and Nestlings of North American Birds – Second Edition*. Princeton University Press, Princeton, New Jersey.
- Bemis, C. and J. D. Rising. 1999. Western Wood-Pewee (*Contopus sordidulus*), *The Birds of North America Online* (A. Poole, Ed.). Ithaca: Cornell Lab of Ornithology. Accessed May 2016.
<<http://bna.birds.cornell.edu/bna/species/451>>
- Bibby, C. J., N. D. Burgess, and D. A. Hill. 1993. *Bird census techniques*. Academic Press, London, England.
- Brown, C.R. and M. Bomberger Brown. 1999. *Barn Swallow (Hirundo rustica)*, *The Birds of North America Online* (A. Poole, Ed.). Ithaca: Cornell Lab of Ornithology; Retrieved from the *Birds of North America*. Accessed August 2014.
<<http://bna.birds.cornell.edu/bna/species/452>>
- Browne, C. L. 2009. *Distribution and population Trends of the Canadian Toad (Anaxyrus hemiophrys) in Alberta*. Alberta sustainable Resource Development, Fish and Wildlife Division. Alberta Species at Risk Report No. 126, Edmonton, AB. 30pp.
- Buehler, D.A. 2000. *Bald Eagle (Haliaeetus leucocephalus)*, *The Birds of North America Online* (A. Poole, Ed.). *The Birds of North America Online*. Accessed May 2016.
<<http://bna.birds.cornell.edu/bna/species/506> doi:10.2173/bna.506>
- City of Edmonton. 2008. *Biodiversity report*. City of Edmonton. Edmonton.
- Connelly, J.W., M.W. Gratson and K.P. Reese. 1998. *Sharp-tailed Grouse (Tympanuchus phasianellus)*, *The Birds of North America Online*. Accessed May 2016.
<<http://bna.birds.cornell.edu/bna/species/354> doi:10.2173/bna.354>
- COSEWIC. 2011. *COSEWIC assessment and status report on the Barn Swallow *Hirundo rustica* in Canada*. Committee on the Status of Endangered Wildlife in Canada. Ottawa.
<www.sararegistry.gc.ca/status/status_e.cfm>

AURUM PROJECT, SE 21-53-23 W4M

References
December 2016

- EPEC Consulting Western Ltd. 1981. *North Saskatchewan River valley and ravine system biophysical study*. Edmonton.
- ESRD (Alberta Environment and Sustainable Resource Development). 2003. Status of the Northern Leopard Frog (*Rana pipiens*) in Alberta: Update 2003. Accessed October 2016. <<http://aep.alberta.ca/fish-wildlife/species-at-risk/species-at-risk-publications-web-resources/amphibians/documents/SAR-StatusNorthernLeopardFrogAlberta-Mar2003.pdf>>
- ESRD. 2012. *Wild species status search*. Accessed May 2016. <<http://esrd.alberta.ca/fish-wildlife/species-at-risk/albertas-species-at-risk-strategy/general-status-of-alberta-wild-species-2010/documents/SAR-2010WildSpeciesGeneralStatusList-Jan2012.pdf>>
- ESRD. 2013. *Sensitive Species Inventory Guidelines*. Edmonton, Alberta. 128 pp.
- ESRD. 2014. *Species assessed by Alberta's Endangered Species Conservation Committee: short list*. Accessed May 2016. <<http://aep.alberta.ca/fish-wildlife/species-at-risk/documents/SpeciesAssessed-Endangered-Jul18-2014.pdf>>
- ESRD. 2015. *Recommended land use guidelines: Key Wildlife and Biodiversity Zones*. Accessed May 2016. <<http://aep.alberta.ca/fish-wildlife/wildlife-land-use-guidelines/documents/KeyWildlifeBiodiversityZones-Apr08-2015.pdf>>
- FAN. 2007. *The atlas of breeding birds of Alberta: a second look*. Federation of Alberta Naturalists, Edmonton.
- Government of Canada. 2015. *The species at risk public registry*. Accessed May 2016. <<https://www.registrelep-sararegistry.gc.ca/default.asp?lang=En&n=24F7211B-1>>
- National Audubon Society (NAS). 2016. *Edmonton Christmas bird count final results*. Accessed May 2016. <<http://ecbcresults.blogspot.ca/>>
- Poole, A.F., R.O. Bierregaard and M.S. Martell. 2002. Osprey (*Pandion haliaetus*). *The Birds of North America Online* (A. Poole, Ed.). Ithaca: Cornell Lab of Ornithology. Accessed May 2016. <<http://bna.birds.cornell.edu/bna/species/683> doi:10.2173/bna.683>
- Spencer, R.B. 1976. *A study of the wildlife of four selected Edmonton ravines and of the recreation uses and preferences for city ravines*. M.Sc. Thesis, University of Alberta. Edmonton.
- Spencer Environmental Management Services Ltd (Spencer). 2014. Aurum Road Clover Bar Ravine Crossing Wildlife Movement and Wetland Analysis. Prepared for the City of Edmonton, Edmonton, Alberta.
- Stantec Consulting Ltd (Stantec). 2007. *Big Lake Neighbourhood One ecological design report*. Edmonton.

AURUM PROJECT, SE 21-53-23 W4M

References

December 2016

Stantec 2008. Phase 1 Ecological Network Report (Revised): Aurum Industrial Business Parks, Area Structure Plan. Prepared for the City of Edmonton, Edmonton, AB.

Stantec. 2014a. *Environmental Impact Assessment for the Terwillegar Park Footbridge and Recreational Trail within portions of 3-, 10-, 11-, 14- and 15-52-25 W4M Edmonton Alberta*. Prepared for the City of Edmonton.

Stantec. 2014b. Pre-disturbance nest survey results for Aurum. Correspondance.

Strong, W.L., J.L. Kansas, K.J. Van Tighem, and B. MacCallum. 1985. *A biophysical inventory and analysis of the Fort Saskatchewan and Devon restricted development areas*. Edmonton.

Strong, W.L. and B. MacCallum. 1984. *A preliminary vegetation and wildlife analysis of the Edmonton – Fort Saskatchewan restricted development area*. Edmonton.

Tarof, S. and J. V. Briskie. 2008. Least Flycatcher (*Empidonax minimus*). *The Birds of North America Online* (A. Poole, Ed.). Ithaca: Cornell Lab of Ornithology. Accessed May 2016
<<http://bna.birds.cornell.edu/bna/species/099/articles/introduction>>

APPENDIX D
FISH AND FISH HABITAT ASSESSMENT

Aurum Road Project

Fish and Fish Habitat Assessment



Prepared for:
Aurum Industrial Development
Partnership

Prepared by:
Stantec Consulting Ltd.

January 17, 2017

Table of Contents

ABBREVIATIONS	I
1.0 INTRODUCTION	1.1
2.0 PROJECT DESCRIPTION	2.1
3.0 REGULATORY CONTEXT	3.1
3.1 WATER ACT	3.1
3.2 FISHERIES ACT	3.1
4.0 METHODS	4.1
4.1 DESKTOP REVIEW	4.1
4.2 FISH AND FISH HABITAT ASSESSMENT	4.1
5.0 RESULTS	5.1
5.1 DESKTOP REVIEW	5.1
5.1.1 Species of Conservation Concern	5.4
5.2 FISH AND FISH HABITAT ASSESSMENT	5.4
5.2.1 Fish Sampling	5.4
5.2.2 Fish Habitat	5.5
6.0 EFFECTS ASSESSMENT AND RECOMMENDATIONS	6.1
6.1 EFFECTS ASSESSMENT	6.1
6.2 RESULTS	6.1
6.3 MITIGATION	6.1
7.0 FINDINGS & RECOMMENDATIONS	7.1
8.0 CLOSING	8.1
9.0 REFERENCES	9.1

LIST OF TABLES

Table 5-1	Historical Fish Presence within the Vicinity of the Project.....	5.2
Table 5-2	Fish Captured in Clover Bar Creek (July 13, 2016)	5.4
Table 5-3	Summary of Fish Habitat Potential on Clover Bar Creek.....	5.5
Table 5-4	In-Situ Water Chemistry in Clover Bar Creek (July 13, 2016)	5.6
Table 6-1	Pathways of Effects for the Proposed Works	6.2
Table 6-2	Mitigation Measures and Breakpoint Linkages to DFO's Pathways of Effects (PoE)	6.5

AURUM ROAD PROJECT

LIST OF APPENDICES

APPENDIX A ENGINEERING DESIGN..... A.1

APPENDIX B SITE PHOTOS..... B.1

APPENDIX C PATHWAYS OF EFFECTS..... C.1

C.1 VEGETATION CLEARING (RIPARIAN) C.1

C.2 RIPARIAN PLANTING C.2

C.3 GRADING C.3

C.4 EXCAVATION C.4

C.5 USE OF EXPLOSIVES C.5

C.6 USE OF INDUSTRIAL EQUIPMENT..... C.6

C.7 PLACEMENT OF MATERIAL OR STRUCTURES IN WATER..... C.7

C.8 DREDGING (INSTREAM EXCAVATION)..... C.9

C.9 STRUCTURE REMOVAL..... C.10

C.10 WATER EXTRACTION..... C.11

C.11 FISH PASSAGE ISSUES C.12

C.12 CHANGE IN TIMING, DURATION AND FREQUENCY OF FLOW C.13

Abbreviations

AEP	Alberta Environment and Parks
AT	Alberta Transportation
COP	Code of Practice
COSEWIC	Committee on the Status of Endangered Wildlife in Canada
DFO	Fisheries and Oceans Canada
ESRD	Alberta Environment and Sustainable Resource Development
FWMIS	Fish and Wildlife Management Information System
GOC	Government of Canada
HWM	High Water Mark
NSR	North Saskatchewan River
QAES	Qualified Aquatic Environment Specialist
RAP	Restricted Activity Period
SARA	<i>Species at Risk Act</i>

AURUM ROAD PROJECT

Introduction
January 17, 2017

1.0 INTRODUCTION

Stantec Consulting Ltd. (Stantec) was retained by Aurum Industrial Development Partnership to provide environmental and regulatory support for the proposed Aurum Road Project (the Project) in Edmonton, Alberta. Aurum Road crosses over the unnamed tributary to the North Saskatchewan River (waterbody ID#: 23359) within SE-21-53-23-W4M, locally known as Clover Bar Creek. The Project has the potential to affect the aquatic environment and fisheries resources; therefore, the Alberta *Water Act* and Federal *Fisheries Act* apply to the Project. As such, a fish and fish habitat assessment was completed at, and adjacent to, the proposed watercourse crossing in mid-July of 2016. This in-situ biophysical fisheries data is required to support the Project's Environmental Impact Assessment and associated regulatory requirements.

The purpose of this report is to provide the results of the fish and fish habitat assessment, evaluate the potential effects to fisheries resources as they relate to Project construction and operation, and provide recommendations relevant to applicable regulatory provisions. A review of the proposed works was completed by a Stantec Biologists and Qualified Aquatic Environment Specialists (QAESs) using Fisheries and Oceans Canada's (DFO's) Self-Assessment criteria (DFO 2016a) and pathways of effects (PoEs; DFO 2014). The evaluation of risk of "serious harm" to fish and a change in "productive capacity" based on the project footprints, construction activities, PoEs, and proposed mitigation, are provided.

The results of this evaluation are intended to support regulatory applications associated with the Project. Due to the nature of the proposed works, it is recommended that a Project specific DFO "Request for Review" be completed and submitted to DFO and that the works proceed under the "Application" process as per the requirements of the Alberta *Water Act*.

AURUM ROAD PROJECT

Introduction
January 17, 2017

AURUM ROAD PROJECT

Project Description
January 17, 2017

2.0 PROJECT DESCRIPTION

The Aurum Industrial Business Park (the Industrial Park), which is currently accessed from Highway 16 via 17 Street NE, has been under development since approximately 2005. As development of the Industrial Park has continued, personnel and traffic associated with businesses within the Industrial Park have increased. Traffic congestion on 17 Street NE has become a regular occurrence, and is exacerbated by the Canadian National (CN) and Canadian Pacific (CP) train tracks that cross 17 Street NE between 127 Avenue NE and Highway 16. Trains on these tracks cause traffic backlogs, while employees who work within the Industrial Park wait to cross the tracks to and/or from their places of business. Aurum Road, which will eventually connect Anthony Henday Drive (Highway 216) (the Henday) to Highway 21, is currently constructed between 17 Street NE and Range Road 232, and between the Henday and 9 Street NE. Construction of Aurum Road that passes through SE-21-53-23-W4M is required to complete the connection to Secondary Highway 21. While the Industrial Park only requires a two-lane roadway to service it, the roadway will ultimately be expanded to six lanes to facilitate the increased traffic this roadway will receive as a bypass route between the Henday and Highway 21. This will bypass both sets of train tracks on 17 Street NE, thereby creating an easily accessible and major route through the Industrial Park.

Aurum Industrial Development Partnership is proposing to cross Clover Bar Creek with the installation of an arch culvert. The arch culvert will be a bottomless, multi-plate, concrete arch structure 21.5 m wide, 8 m in height and 67 m in length. The arch culvert will be supported by a foundation set onto geotechnical H-pile, driven deep into the competent bedrock material below the ravine. A portion of Clover Bar Creek will be realigned in order to accommodate flow through the arched culvert. Design of the creek realignment were informed by the hydraulic modeling completed during the design process to be consistent with flow rates of the creek after construction as they were prior to realignment. Maintaining (within maximum 20% variation) flow rates within the creek is critical to the function of the watershed the creek is part of the design. However, the realignment will shorten the creek from 174 m to 103 m in length resulting in a total loss of 690 m² of area. The realignment will consist of a sinuous length of creek that is approximately 4.5 m wide at its base and has been designed to the standard 100- year storm event but will accommodate a 200- year event within the freeboard area. The base of the realignment will consist of disturbed clay overlain by 200 mm depth of 75 mm crushed rock and 50 mm sand, overlain by 75 mm depth of 40 mm rainbow rock with 25 mm sand. The realignment will be armoured with landscape fabric, stabilization boulders 400 – 600 mm thick, by 600 - 800 mm wide, by 1 – 2 m long stepped to the 1:100 year flood line. The realigned channel will have an incised channel 1 m wide with sloped sides, 4 deep pools, riffles consisting of river rock placed throughout the creek and root wads. Aurum creek realignment design figures are included in Appendix A Figures.

AURUM ROAD PROJECT

Project Description
January 17, 2017

3.0 REGULATORY CONTEXT

3.1 WATER ACT

The construction of a watercourse crossing, including a temporary crossing, or any activity associated with the construction, maintenance, replacement or removal, which includes works for a Type 1 crossing, Type 2 crossing, Type 3 crossing, Type 4 crossing or Type 5 crossing, as defined in the *Code of Practice (COP) for Watercourse Crossings* (ESRD 2013), are works that are exempt from further approval requirements under the *Alberta Water Act*, provided all requirements of the COP are met.

A key component of the COP is that the proposed works meet the requirements of clause (a) in Part 1 of Schedule 2 that states:

“Upon completion of the works, the quantity and productive capacity of the aquatic environment, including fish habitat, at the watercourse crossing site, where technically feasible, and adjacent to the watercourse crossing site must be equivalent to or exceed that which existed prior to commencing the works”

Determination that a proposed works will meet the requirements of clause (a) in Part 1 of Schedule 2 must be conducted by a QAES. In some cases, the written specifications and recommendations of a QAES are required to meet clause (a) in Part 1 of Schedule 2.

This report presents a review of the proposed works by a QAES and a conclusion regarding the likelihood of compliance with clause (a) in Part 1 of Schedule 2 of the COP. This report also includes the written specifications and recommendations of a QAES that will be required to meet clause (a) in Part 1 of Schedule 2.

3.2 FISHERIES ACT

The federal *Fisheries Act* includes the fisheries protection prohibiting “serious harm” to fish that are part of or that support a commercial, recreational or Aboriginal (CRA) fishery. DFO interprets “serious harm” to fish as the death of fish or any permanent alteration to, or destruction of, fish habitat. Project activities that result in “serious harm” to fish that are part of, or support a CRA fishery require Authorization under section 35(2)(b) of the *Fisheries Act*. Projects that are unlikely to cause “serious harm” to fish may proceed without DFO review or Authorization.

The written specifications and recommendations provided herein have also been developed to promote Project compliance with the *Fisheries Act*. This report includes an assessment and likelihood of the proposed works to cause “serious harm” to fish upon the implementation of the specifications and recommendations made herein.

AURUM ROAD PROJECT

Regulatory Context
January 17, 2017

4.0 METHODS

4.1 DESKTOP REVIEW

A review of fish and fish habitat information for Clover Bar Creek was completed over a 5 km length of channel, extending both upstream (to the headwaters) and downstream (to the confluence with the North Saskatchewan River (NSR)) from the proposed culvert crossing location. A portion of the NSR (approximately 2.7 km downstream of the Clover Bar Creek confluence is included within this Study Area in order to: 1) adequately include downstream portion of the assessment area as Clover Bar Creek only extends 2.3 km below the proposed crossing location before entering the NSR; and 2) document fish species that may seasonally migrate between these waterbodies. A review of Alberta Environment and Parks' (AEP's) Fish and Wildlife Management Information System (FWMIS) database (AEP 2016) provided data on recorded fish presence near the Project.

Fish species information was cross-referenced with the provincial *Wildlife Act* (Wildlife Regulation 1997) and federal *Species at Risk Act* (SARA 2002) listings to determine if fish species identified in the Study Area are listed as *special status* species. Other species designations and status reports were also considered, including the General Status of Alberta Wild Species (ESRD 2012a) and the Committee on the Status of Endangered Wildlife in Canada (COSEWIC) (GOC 2014).

Watercourse class and restricted activity period (RAP) for instream activities were identified from the COP for Watercourse Crossings (ESRD 2013) and the Code of Practice St. Paul Management Area Map (ESRD 2012b).

4.2 FISH AND FISH HABITAT ASSESSMENT

Two Stantec QAESs visited the proposed crossing location on July 13, 2016, to identify existing conditions for fish and fish habitat within Clover Bar Creek, using procedures based on standard protocols outlined in Alberta Transportation's (AT) Fish Habitat Manual (AT 2009) and Schedule 4 of the COP (ESRD 2013), and to document the downstream connectivity within the creek and to the NSR.

4.2.1.1 Fish Sampling

Prior to the field program, a Fish Research License (FRL) was obtained from AEP (License No: 16-3823) in order to collect fish for research and/or inventory.

Equipment used to capture fish included a backpack electrofishing unit and three minnow traps. Captured fish were placed in a holding tank until they were processed. Fish were identified to species, examined for any deformities, sexed (if possible), weighed, and measured for length. Fish were then released back to the watercourse. All fish capture data obtained under the FRL was submitted to AEP on July 19, 2016.

AURUM ROAD PROJECT

Methods

January 17, 2017

4.2.1.2 Fish Habitat

The assessment included six transects; located 100 m upstream, 50 m upstream, at the proposed crossing location, and 100 m, 200 m and 300 m downstream of the proposed crossing location to include the area which may be affected by sediment (i.e., the zone of impact). Field information and observations were recorded and included the following, where possible:

- date and time
- photographs
- habitat-type (e.g., pool, riffle, and run) and area
- channel characteristics (e.g., channel and wetted widths, depths, gradient)
- bed material (substrate size distribution)
- obstructions
- bank characteristics
- vegetation (instream and riparian)
- in situ water chemistry
- flood signs
- stage of stream

Bank materials, bank stability, bank slopes, cover, vegetation, and fish habitat were estimated visually. Channel width, wetted width, water depth and bank heights were measured with a measuring stick. Instream substrate composition was estimated visually at each transect. *In situ* water chemistry (i.e., pH [± 0.2 unit], temperature [$\pm 0.2^\circ\text{C}$], conductivity [$\pm 5\%$ of reading], and dissolved oxygen [± 0.4 mg/L]) were measured using a hand-held YSI Professional Plus Water Quality Meter.

Fish passage within Clover Bar Creek and habitat connectivity to the NSR was also documented. Fish habitat suitability for migration, spawning, rearing, and overwintering for Clover Bar Creek at the proposed crossing was evaluated according to the site's suitability for fish species documented (Nelson and Paetz 1992; and Scott and Crossman 1998).

5.0 RESULTS

5.1 DESKTOP REVIEW

Clover Bar Creek originates approximately 4 km southeast from the proposed crossing in the vicinity of the intersection of Lakeland Drive and Clover Bar Road (Edmonton, Alberta) and flows in a northwesterly direction for approximately 6.5 km before entering the NSR. Anthropogenically transformed landscapes (i.e., storm water ponds, highways interchanges, highway and road crossings, ditches, and clearings) are present throughout, however a notably high density of human development is present with the upper and lower reaches of Clover Bar Creek.

As per the Code of Practice St. Paul Management Area Map (ESRD 2012b), in the area of the proposed crossing, Clover Bar Creek is unmapped waterbody which enters into a mapped Class A section of the NSR (ESRD 2012b). As Clover Bar Creek does not enter the NSR via an outfall structure, it is subject to special conditions: "*Class A status applies to the 100 metre portion of the tributary upstream from its confluence with the North Saskatchewan River. Class C status applies to the portion of the tributary upstream of the Class A reach.*" (ESRD 2012b). The proposed crossing location is approximately 2.3 km from the confluence, and as such is assigned a Class C status with a RAP extending from September 16 to July 31 (ESRD 2012b; ESRD 2013).

Three fish species have been documented in Clover Bar Creek: (brook stickleback (*Culaea inconstans*), fathead minnow (*Pimephales promelas*), and white sucker (*Catostomus commersonii*). However, an additional 19 fish species have been documented (AEP 2016) within the portion of the NSR that was included in the Study Area (Table 5-1).

AURUM ROAD PROJECT

Results
January 17, 2017

Table 5-1 Historical Fish Presence within the Vicinity of the Project

Family	Scientific Name	Common Name	Legislated Protection		Scientific Review or Recommendation	
			SARA ¹	Alberta Wildlife Act ²	COSEWIC ³	General Status of Alberta Wild Species ⁴
Acipenseridae	<i>Acipenser fulvescens</i>	Lake sturgeon	No status	Threatened	Endangered	Undetermined
Catostomidae (sucker family)	<i>Catostomus catostomus</i>	Longnose sucker	No status	Not listed	Not assessed	Secure
	<i>Moxostoma macrolepidotum</i>	Shorthead redhorse	No status	Not listed	Not assessed	Secure
	<i>Catostomus commersonii</i>	White sucker*	No status	Not listed	Not assessed	Secure
Cottidae (sculpin family)	<i>Cottus ricei</i>	Spoonhead sculpin	No status	Not listed	Not at risk	May be at risk
Cyprinidae (minnow family)	<i>Notropis atherinodes</i>	Emerald shiner	No status	Not listed	Not assessed	Secure
	<i>Pimephales promelas</i>	Fathead minnow*	No status	Not listed	Not assessed	Secure
	<i>Phoxinus neogaeus</i>	Finescale dace	No status	Not listed	Not assessed	Undetermined
	<i>Couesius plumbeus</i>	Lake chub	No status	Not listed	Not assessed	Secure
	<i>Rhinichthys cataractae</i>	Longnose dace	No status	Not listed	Not assessed	Secure
	<i>Phoxinus eos</i>	Northern redbelly dace	No status	Not listed	Not assessed	Sensitive
	<i>Notropis blennioides</i>	River shiner	No status	Not listed	Not assessed	Undetermined
	<i>Notropis hudsonius</i>	Spottail shiner	No status	Not listed	Not assessed	Secure
Esocidae	<i>Esox Lucius</i>	Northern pike	No status	Not listed	Not assessed	Secure
Gasterosteidae (stickleback family)	<i>Culaea inconstans</i>	Brook stickleback*	No status	Not listed	Not assessed	Secure
Hiodnotidae (mooneye family)	<i>Hiodon tergisus</i>	Mooneye	No status	Not listed	Not assessed	Secure
	<i>Hiodon alosoides</i>	Goldeye	No status	Not listed	Not assessed	Secure



AURUM ROAD PROJECT

Results
January 17, 2017

Table 5-1 Historical Fish Presence within the Vicinity of the Project

Family	Scientific Name	Common Name	Legislated Protection		Scientific Review or Recommendation	
			SARA ¹	Alberta Wildlife Act ²	COSEWIC ³	General Status of Alberta Wild Species ⁴
Percidae (perch family)	<i>Stizostedion vitreum</i>	Walleye	No status	Not listed	Not assessed	Secure
Salmonidae (salmon and trout family)	<i>Prosopium williamsoni</i>	Mountain whitefish	No status	Not listed	Not assessed	Secure
NOTES: * documented in Clover Bar Creek 1 Species at Risk Act (SARA 2002) (GOC 2016) 2 Wildlife Act Wildlife Regulation (1997) 3 Government of Canada (2014) 4 ESRD (2012)						

AURUM ROAD PROJECT

Results

January 17, 2017

5.1.1 Species of Conservation Concern

A total of five species of conservation concern were identified within the Study Area (Table 5-1).

Lake sturgeon is provincially listed as “Threatened” and “Endangered” under the Alberta *Wildlife Act* and COSEWIC, respectively.

Under the Alberta Wild Species 2010 report (ESRD 2012a), lake sturgeon, finescale dace and river shiner were listed as “Undetermined”, and spoonhead sculpin and northern redbelly dace as “May be at Risk” and “Sensitive”, respectively. All five of these species were found in the NSR, but have not been documented in Clover Bar Creek.

5.2 FISH AND FISH HABITAT ASSESSMENT

The fish and fish habitat assessment was conducted from the creek banks and instream where water depths permitted. Seasonal flow conditions were present and while no precipitation had occurred in the 24 hours preceding the assessment, a short rain event was recorded during the field visit. Representative site photographs, depicting habitat features at the time of the assessment, are provided in Appendix B.

5.2.1 Fish Sampling

The fish sampling in Clover Bar Creek resulted in the capture of 22 fish across 4 species. Table 5-2 lists the species captured and method used.

Table 5-2 Fish Captured in Clover Bar Creek (July 13, 2016)

Method	Species	# captured
Backpack electrofishing	Brook stickleback	5
	Longnose sucker	1
	White sucker	1
Minnow traps	Brook stickleback	11
	Fathead minnow	2
	White sucker	2
Total		22

AURUM ROAD PROJECT

Results

January 17, 2017

5.2.2 Fish Habitat

The proposed crossing location is situated in the downstream portion of a beaver impoundment with channel and wetted width measured at 3.8 m, and maximum depth measured at 0.9 m. Substrates were comprised mainly of fines (85%), with some organics (5%) and gravels (10%).

Habitat upstream of the proposed crossing location was type R3 run habitat with limited depths and a substrate composed of a mix of fines and gravels. Maximum depth ranged from 0.28 m to 0.35 m deep.

Habitat downstream of the proposed crossing location continuously alternated between riffles, shallow runs, and shallow pools. Substrates were predominantly coarse, with the majority (50-70%) consisting of large gravel. Maximum depths at the transect locations ranged from 0.16 m to 0.26 m. Maximum recorded pool depth was 0.58 m deep.

An assessment of fish spawning, rearing, migration and overwintering potential in the vicinity of the proposed crossing is summarized below in Table 5-3.

Table 5-3 Summary of Fish Habitat Potential on Clover Bar Creek

Habitat	Rating
Spawning	<u>Moderate to Good</u> : the habitat downstream from the proposed crossing location provides spawning substrates suitable for species that rely on gravels (e.g., salmonids and suckers) and woody debris and instream vegetation (e.g., minnows). Habitat upstream of the proposed crossing provides more aquatic vegetation and instream woody debris suitable for minnow species and northern pike.
Rearing	<u>Moderate to Good</u> : Abundant backwaters, undercut banks, woody debris, and overhanging vegetation provide good cover for small-bodied fish species and juvenile large-bodied fish. The shallow depths favour smaller-bodied fish in this watercourse.
Migration	<u>Moderate</u> : sufficient depths provide fish passage within the system. However, beaver activity (i.e., dams and associated impoundments) and anthropogenic activity (i.e., culverts, roads, ditches, and clearings) may limit upstream movement of fish to and above the proposed crossing location.
Overwintering	<u>Nil to Poor</u> : observed water depths were insufficient for overwintering habitat (i.e., > 1.0 m) and it is anticipated that the watercourse will be dry or frozen-to-bottom during the winter months. Overwintering habitat would be limited to the beaver ponds and associated low dissolved oxygen.

Overall, fish habitat within Clover Bar Creek was moderate for all fish species but favours small-bodied individuals. Moderate to good spawning and rearing habitat was observed. However, migration may be limited by the beaver dams and the anthropogenic activity (i.e., culverts, roads, ditches, and clearings) found along Clover Bar Creek. Overwintering habitat is the most limiting habitat factor as areas of adequate depth (i.e., > 1.0 m) were not observed.

AURUM ROAD PROJECT

Results

January 17, 2017

Water quality measurements taken during the assessment on Clover Bar Creek are presented below in Table 5-4.

Table 5-4 In-Situ Water Chemistry in Clover Bar Creek (July 13, 2016)

Parameter	Value
Temperature (°C)	21.7
Dissolved oxygen (mg/L)	8.8
Specific conductivity (µS/cm)	564
pH	7.2
Turbidity (NTU)	26.9

6.0 EFFECTS ASSESSMENT AND RECOMMENDATIONS

6.1 EFFECTS ASSESSMENT

DFO has developed Self-Assessment criteria (DFO 2016a) and Measures to Avoid Causing Harm to Fish and Fish Habitat Including Aquatic Species at Risk (DFO 2016b) to aid in the assessment of the potential for activities to cause “serious harm” to fish. The installation of a culvert (i.e., open bottom) over a watercourse is not listed under “Project activities and criteria where DFO review is not required” (DFO 2016a). The proposed works were therefore evaluated using DFO’s Pathways of Effects (PoE) (DFO 2014) to assess the potential project-related effects on fisheries resources. This approach:

- identifies the potential project-related effects that may occur as a result of the proposed works;
- identifies the relevant PoEs for the proposed works;
- prescribes site-specific measures and mitigation to “break” the PoE; and
- evaluates whether the proposed works have the potential to result in “serious harm” to fish or results in a change in “productive capacity”.

This methodology is used to assess the potential for effects to the aquatic environment and to concurrently evaluate the Project as it relates to the Alberta *Water Act* and federal *Fisheries Act*.

6.2 RESULTS

A total of nine PoEs were identified for the Project as having the potential to cause an effect on fisheries resources (Table 6-1). Four of these are associated with land-based activities, one with both land-based and water-based activities, and four with water-based activities.

These PoEs and the stressors (or potential effects) of each Project component on fisheries resources are listed in Table 6-1. Each PoE is described in more detail in Appendix C. Following application of these mitigation measures the Project is found to have residual effects on fisheries resources through the potential effects of two PoEs related to in-water activities (i.e., Placement of Materials or Structures in Water, Dredging, and Fish Passage Issues).

6.3 MITIGATION

Mitigation measures, used to assess the residual stressor(s) that should be followed to reduce or eliminate the potential effects within Clover Bar Creek) are described in Table 6-2. The mitigation measures provided are in alignment with DFO’s Measures to Avoid Causing Harm to Fish and Fish Habitat, including Aquatic Species at Risk.

AURUM ROAD PROJECT

Effects Assessment and Recommendations
 January 17, 2017

Table 6-1 Pathways of Effects for the Proposed Works

Pathways of Effects	Stressor (Potential Effects)	Residual Stressor(s) after Mitigation	Potential to Cause Serious Harm?	Potential to Change Productive Capacity?
Land-Based Activities				
Vegetation Clearing (Appendix C.1)	<ul style="list-style-type: none"> • Change in habitat structure and cover • Change in sediment concentrations • Change in water temperature • Change in food supply • Change in nutrient concentrations 	Yes – A permanent change in habitat structure and cover is anticipated where riparian vegetation is no longer present under the arch culvert.	Unlikely Nil to low potential	Unlikely Nil to low potential
Riparian Planting (Appendix C.2)	<ul style="list-style-type: none"> • Change in sediment concentrations • Change in nutrient concentrations • Change in contaminant concentrations • Change in water temperature • Change in habitat structure and cover • Change in food supply 	Yes – A permanent change in habitat structure and cover is anticipated where riparian vegetation is altered (i.e., plantings) upstream and downstream of the arch culvert.	Unlikely Nil to low potential	Unlikely Nil to low potential
Grading (Appendix C.3)	<ul style="list-style-type: none"> • Change in habitat structure and cover • Change in sediment concentrations 	No	Not Anticipated	Not Anticipated
Excavation (Appendix C.4)	<ul style="list-style-type: none"> • Change in baseflow • Change in base water temperature • Change in sediment concentrations 	No	Not Anticipated	Not Anticipated
Use of Explosives (Appendix C.5)	<ul style="list-style-type: none"> • Not Applicable – the use of explosives during the construction of Aurum Road is not anticipated 	Not Applicable	Not Applicable	Not Applicable



AURUM ROAD PROJECT

Effects Assessment and Recommendations
January 17, 2017

Table 6-1 Pathways of Effects for the Proposed Works

Pathways of Effects	Stressor (Potential Effects)	Residual Stressor(s) after Mitigation	Potential to Cause Serious Harm?	Potential to Change Productive Capacity?
Land-Based Activities and In-Water Activities				
Use of industrial equipment (Appendix C.6)	<ul style="list-style-type: none"> • Potential mortality of fish/eggs/ova from equipment • Change in sediment concentrations • Change in contaminant concentrations 	No	Not Anticipated	Not Anticipated
In-Water Activities				
Placement of Materials or Structures in Water (Appendix C.7)	<ul style="list-style-type: none"> • Change in sediment concentrations • Change in habitat structure and cover • Change in food supply • Change in nutrient concentrations 	Yes – A permanent change in habitat structure and cover is anticipated where the channel re-alignment overlaps the original footprint of Clover Bar Creek. The Project's design also anticipates a permanent loss of 690 m ² of instream habitat.	Yes Moderate potential	Yes Moderate potential
Dredging (Appendix C.8)	<ul style="list-style-type: none"> • Change in food supply • Change in habitat structure and cover • Change in sediment concentrations • Change in contaminant concentrations • Change in nutrient concentrations 	Yes – A permanent change in habitat structure and cover is anticipated where the channel re-alignment overlaps the original footprint of the Clover Bar Creek. The Project's design also anticipates a permanent loss of 690 m ² of instream habitat.	Yes Low to moderate potential	Yes Low to moderate potential
Structure Removal (Appendix C.9)	<ul style="list-style-type: none"> • Not Applicable – removal of an existing structure during the construction of Aurum Road is not anticipated. 	Not Applicable	Not Applicable	Not Applicable

AURUM ROAD PROJECT

Effects Assessment and Recommendations
 January 17, 2017

Table 6-1 Pathways of Effects for the Proposed Works

Pathways of Effects	Stressor (Potential Effects)	Residual Stressor(s) after Mitigation	Potential to Cause Serious Harm?	Potential to Change Productive Capacity?
Water Extraction (Appendix C.10)	<ul style="list-style-type: none"> • Not Applicable – the extraction of water during construction of Aurum Road is not anticipated. 	Not Applicable	Not Applicable	Not Applicable
Fish Passage Issues (Appendix C.11)	<ul style="list-style-type: none"> • Incidental entrainment, impingement or mortality of resident species. • Change in access to habitats 	Yes – A temporary change in access to habitat is anticipated during construction as the instream isolation (and bypass) will limit upstream and downstream fish movement.	Yes Low to moderate potential	Yes Low to moderate potential
Change in timing, duration and frequency of flow (Appendix C.12)	<ul style="list-style-type: none"> • Displacement or stranding of fish • Change in sediment concentrations • Change in habitat structure and cover • Change in food supply • Change in water temperature • Change in contaminant concentrations • Change in nutrient concentrations 	No	Not Anticipated	Not Anticipated

AURUM ROAD PROJECT

Effects Assessment and Recommendations
 January 17, 2017

Table 6-2 Mitigation Measures and Breakpoint Linkages to DFO’s Pathways of Effects (PoE)

Mitigation Type	Mitigation Description	Applicable PoE Breakpoint
Timing	Schedule work to avoid wet, windy, and rainy periods that may increase erosion and sedimentation.	BP2.1, BP3.2, BP3.4, BP4.3, BP4.4, BP4.5, BP8.3
	Minimize the duration of in-water work.	BP6.1, BP6.3, BP6.4, BP9.1, BP11.1, BP11.2, BP11.3
	Conduct instream work during periods of low flow, to further reduce the risk to fish and their habitat or to allow work in water to be isolated from flows.	BP6.1, BP6.3, BP8.3, BP9.1, BP11.2, BP11.3, BP12.1, BP12.2, BP12.3, BP12.4
Operation of Machinery	Ensure that machinery arrives on site in a clean condition and is maintained free of fluid leaks, invasive species, and noxious weeds.	BP6.4
	Develop and implement a Containment and Spill Management Plan that reduces the risk of accidental spills or releases from entering a watercourse or water body during all phases of the crossing.	BP6.4
	Whenever possible, operate machinery on land above the high water mark (HWM), on ice, or from a floating barge in a manner that minimizes disturbance to the banks and bed of the water body.	BP1.2, BP1.3, BP2.1, BP3.2, BP6.1, BP6.2, BP6.3, BP6.4, BP8.2, BP8.3, BP8.4
	Wash, refuel and service machinery and store fuel and other materials for the machinery in such a way as to prevent any deleterious substances from entering the water.	BP6.4
	Remove all construction materials from site upon crossing completion.	BP7.1, BP7.2, BP7.3, BP8.1, BP9.1, BP9.2
	Limit machinery fording of the watercourse to a one-time event (i.e., over and back), and only if no alternative crossing method is available. If repeated crossings of the watercourse are required, construct a temporary crossing structure.	BP6.1, BP6.2, BP6.3, BP6.4

AURUM ROAD PROJECT

Effects Assessment and Recommendations
January 17, 2017

Table 6-2 Mitigation Measures and Breakpoint Linkages to DFO's Pathways of Effects (PoE)

Mitigation Type	Mitigation Description	Applicable PoE Breakpoint
Erosion and Sediment Control	Install effective erosion and sediment control measures before starting work to prevent sediment from entering the water body. Regularly inspect and maintain erosion and sediment control measures and structures during the course of construction. Repair erosion and sediment control measures and structures, if damage occurs. Remove non-biodegradable erosion and sediment control materials once site is stabilized.	BP1.2, BP1.3, BP1.4, BP2.1, BP2.3, BP2.4, BP3.1, BP4.1, BP4.2, BP4.3, BP7.2, BP7.3, BP7.4, BP8.1, BP8.2, BP8.3, BP12.4
	Implement measures for managing water flowing onto the site, as well as water being pumped or diverted from the site, such that sediment is filtered out prior to the water entering a water body.	BP1.3, BP1.5, BP3.4, BP4.2, BP4.3, BP4.4, BP8.3, BP12.1
	Implement measures for site isolation (e.g., silt boom or silt curtain) for containing suspended sediment, if in-water work is required.	BP6.3, BP8.3
	Implement measures for containing and stabilizing waste material (e.g., dredging spoils, construction waste and materials, commercial logging waste, uprooted or cut aquatic plants, and accumulated debris) above the HWM of nearby watercourses and/or water bodies to prevent re-entry.	BP1.3, BP1.5, BP4.5, BP8.3
	Implement subsurface drainage controls, where appropriate, to maintain groundwater and surface water interactions and to maintain the stability of reclaimed land. The type and location of subsurface drainage controls should be determined through onsite investigation with considerations for: subsurface flow potential, erodibility of backfill materials, and degree of slope.	BP3.3, BP4.1
	When dewatering excavations or work areas (if required), remove suspended solids by diverting water into a vegetated area or settling basin, and prevent sediment and other deleterious substances from entering the watercourse.	BP3.3, BP4.1, BP4.2, BP6.4

AURUM ROAD PROJECT

Effects Assessment and Recommendations
January 17, 2017

Table 6-2 Mitigation Measures and Breakpoint Linkages to DFO's Pathways of Effects (PoE)

Mitigation Type	Mitigation Description	Applicable PoE Breakpoint
Maintenance and Reclamation	Minimize the removal of natural woody debris, rocks, sand or other materials from the banks, the shoreline or the bed of the watercourse or water body below the HWM. If material is removed from the water body, set it aside and return it to the original location once construction activities are completed.	BP1.2, BP1.4, BP1.5, BP2.3, BP2.4, BP3.1, BP4.1
	Revegetate areas with surface (i.e., terrestrial) disturbance following construction works. If there is insufficient time remaining in the growing season, the site should be stabilized (e.g., cover exposed areas with erosion control blankets to keep the soil in place and prevent erosion) and vegetated the following spring.	BP1.2, BP1.3, BP1.4, BP1.5, BP2.1, BP2.3, BP2.4, BP3.4, BP4.4
	If replacement materials (e.g., rock reinforcement or armouring) are required to stabilize eroding or exposed areas, ensure that appropriately-sized, clean material is used; and that materials are installed at a similar slope to maintain a uniform bank/shoreline and natural stream/shoreline alignment.	BP3.2, BP3.3
	Revegetate streambanks and approach slopes with an appropriate native seed mix or erosion control mix.	BP2.1, BP2.3, BP2.4
	Develop specific procedures to prevent the invasion or spread of undesirable non-native vegetation (e.g., purple loosestrife and Eurasian milfoil).	BP2.4, BP7.3
Riparian Vegetation Removal	Design and construct approaches to the watercourse or water body such that they are perpendicular to the watercourse or water body to minimize loss or disturbance to riparian vegetation.	BP1.2, BP1.3, BP1.4, BP1.5, BP3.1, BP3.2, BP3.3, BP8.4
	Establish an appropriate vegetative buffer (i.e., set-back) from the HWM and locate all temporary workspaces outside the buffer.	BP4.3, BP4.4, BP4.5
	Clearing of riparian vegetation should be kept to a minimum; use existing trails, roads or cut lines wherever possible to avoid disturbance to the riparian vegetation and prevent soil compaction. When practicable, prune or top the vegetation instead of grubbing/uprooting.	BP1.3, BP1.4

AURUM ROAD PROJECT

Effects Assessment and Recommendations
 January 17, 2017

Table 6-2 Mitigation Measures and Breakpoint Linkages to DFO’s Pathways of Effects (PoE)

Mitigation Type	Mitigation Description	Applicable PoE Breakpoint
Instream Works	<p>Screen any water intakes pipes to prevent entrainment or impingement of fish. Entrainment occurs when a fish is drawn into a water intake and cannot escape. Impingement occurs when an entrapped fish is held in contact with the intake screen and is unable to free itself. In freshwater, follow these measures for design and installation of intake end of pipe fish screens to protect fish where water is extracted from fish-bearing waters:</p> <ul style="list-style-type: none"> • Screens should be located in areas and depths of water with low concentrations of fish throughout the year. • Avoid placing water intakes/screens in areas of the channel that are used as migratory corridors by fish, where possible. Additional protection measures (e.g., barrier nets) may also be required. • Screens should be located away from natural or artificial structures that may attract fish that are migrating, spawning, or in rearing habitat. • The screen face should be oriented in the same direction as the flow. • Ensure openings in the guides and seals are less than the opening criteria to make “fish tight”. • Intakes should be installed in a manner that prevents the uptake or entrainment of sediment and aquatic organisms associated with the bottom area. Screens should be located a minimum of 300 mm (12 in.) above the bottom of the watercourse. If the water depth is less than 300 mm (12 in.), additional measures may need to be implemented (e.g., using a screen basket with a solid bottom). • Structural support should be provided to the screen panels to prevent sagging and collapse of the screen. • Large cylindrical and box-type screens should have a manifold installed in them to ensure even water velocity distribution across the screen surface. The ends of the structure should be made out of solid materials and the end of the manifold capped. • Heavier cages or trash racks can be fabricated out of bar or grating to protect the finer fish screen, especially where there is debris loading (woody material, leaves, algae mats, etc.). A150 mm (6 in.) spacing between bars is typical. • Provision should be made for the removal, inspection, and cleaning of screens. • Ensure regular maintenance and repair of cleaning apparatus, seals, and screens is carried out to prevent debris-fouling and impingement of fish. • Pumps should be shut down when fish screens are removed for inspection and cleaning. 	BP11.1, BP12.1



AURUM ROAD PROJECT

Effects Assessment and Recommendations
 January 17, 2017

Table 6-2 Mitigation Measures and Breakpoint Linkages to DFO’s Pathways of Effects (PoE)

Mitigation Type	Mitigation Description	Applicable PoE Breakpoint
Instream Works (cont’d)	The following measures will be implemented when using a flume (or equivalent) isolated construction method: <ul style="list-style-type: none"> • Conduct a rescue of fish that could be trapped within the isolated area and place downstream of the isolated area. • Ensure the flume, including dams or wing walls (if applicable), is installed in a manner that prevents disturbance to the channel bed. • Ensure the flume is sized to accommodate any expected high flows of the watercourse during the construction period. • The flume, including dams or wing walls (if applicable), should be monitored at all times, and contingency measures and materials should be developed and on site in case of a failure. • Protect the flume outflow area to prevent erosion and the release of suspended sediments downstream, and remove this material when the works have been completed. • When removing the isolation, gradually remove the downstream dam/wing wall first, to equalize water levels inside and outside of the isolated area and to allow suspended sediments to settle. During the final removal of isolation, restore the original channel shape, bottom gradient and substrate at these locations. 	BP6.1, BP11.1, BP12.1
	Develop and implement a Sediment Monitoring and Response Plan that outlines measures to: <ul style="list-style-type: none"> • Monitor the watercourse to detect signs of sediment releases into surface waters during all phases of construction. • Criteria for stopping suspended construction in the event a sediment release is detected. • Contain, clean-up and prevent sediment release, including materials required on-site. • Notification of applicable authorities and criteria for work re-start. 	BP3.4, BP6.2, BP6.3, BP7.1, BP 8.2, BP8.3, BP12.1

AURUM ROAD PROJECT

Effects Assessment and Recommendations
January 17, 2017

AURUM ROAD PROJECT

Findings & Recommendations
January 17, 2017

7.0 FINDINGS & RECOMMENDATIONS

This report documents current fish and fish habitat in Clover Bar Creek at the proposed crossing location of Aurum Road, and discusses the potential for causing “serious harm” and/or a change in “productive capacity” as a result of Project works.

Potential effects of the Project on Clover Bar Creek are greatest instream as there will be:

- A permanent change in habitat structure and cover as the channel re-alignment overlaps the original footprint of Clover Bar Creek. In addition, a permanent change in the riparian vegetation under the arch culvert is anticipated as a result of increased shading.
- A permanent loss of 690 m² of instream habitat resulting from the smaller footprint of the channel realignment.
- A temporary reduction in fish passage is anticipated during construction as the instream isolation (and bypass) may limit upstream and downstream fish movement during the RAP.

As a result, the potential to cause “serious harm” and a change in “productive capacity” to the fisheries resources in Clover Bar Creek is considered to be present. Stantec therefore recommends that the Project proceed with a DFO Request for Review and an Application under the *Alberta Water Act* to meet regulatory compliance.

In addition, with the objective of facilitating regulatory review and minimizing conditions associated with regulatory approval, it is further recommended that both the DFO Request for Review and *Alberta Water Act* Application highlight that:

- The design of the Project’s channel realignment includes a number of habitat features (e.g., deep pools and areas of depth, boulder clusters, and steep bank heights) that are locally limited in Clover Bar Creek.
- The fish species anticipated to directly interact with the Project are limited to brook stickleback, fathead minnow, longnose sucker and white sucker, none of which are a “Species of Conservation Concern” or directly constitute a “CRA fishery”.
- Fish passage within Clover Bar Creek (i.e., passage within the creek itself and migration between the creek and the NSR) is limited due to the documented density and nature of anthropogenic activity (i.e., culverts, roads, ditches, and clearings) throughout the watercourse.
- A request to modify the COP assigned RAP (i.e., September 16 to July 31) to “April 16 to June 30” should be considered as it is better suited for the fish species and habitat documented in Clover Bar Creek. Input and approval from both the local Provincial Fisheries Biologist and Water Act Licensing Officer is required. Regardless, QAES recommendations will be required if the Project overlaps with the Clover Bar Creek RAP.

AURUM ROAD PROJECT

Findings & Recommendations
January 17, 2017

AURUM ROAD PROJECT

Closing
January 17, 2017

8.0 CLOSING

This report is intended to support regulatory requirements for the Project. Mitigation measures outlined in this report reflect the anticipated designs for the construction of Aurum Road over Clover Bar Creek.

STANTEC CONSULTING LTD.



John Jackson, M.Sc.
Senior Fisheries Biologist
Phone: (403) 716-8136
Fax: (403) 269-5245
John.Jackson@stantec.com

AURUM ROAD PROJECT

Closing
January 17, 2017

AURUM ROAD PROJECT

References
January 17, 2017

9.0 REFERENCES

Alberta Environment Parks (AEP). 2016. Fish and Wildlife Management Information System.
Available at: <http://aep.alberta.ca/fish-wildlife/fwmis/access-fwmis-data.aspx>

Alberta Environment and Sustainable Resource Development (ESRD). 2012a. Alberta Wild Species General Status Listing. Current to January 26, 2012. Accessed July 2016 from:
<http://aep.alberta.ca/fish-wildlife/species-at-risk/albertas-species-at-risk-strategy/general-status-of-alberta-wild-species-2010/documents/SAR-2010WildSpeciesGeneralStatusList-Jan2012.pdf>

Alberta Environment and Sustainable Resource Development (ESRD). 2012b. St. Paul Management Area Map for ESRD Codes of Practice. Edmonton, Alberta.

Alberta Environment and Sustainable Resource Development (ESRD). 2013. Code of Practice for Watercourse Crossings. Consolidated to include amendments as of June 24, 2013. Alberta Queen's Printer, Edmonton, AB.

Alberta Transportation (AT). 2009. Fish Habitat Manual, Guidelines and Procedures for Watercourse Crossings in Alberta. Edmonton, Alberta.

CAPP (Canadian Association of Petroleum Producers). 2005. *Pipeline Associated Watercourse Crossings – 3rd Edition*.

Fisheries and Oceans Canada (DFO). 1995. Freshwater Intake End-of-Pipe Fish Screen Guidelines. Communication Directorate Fisheries and Oceans Canada. DFO/5080. Ottawa, Ontario, Canada.

Fisheries and Oceans Canada (DFO). 2014. Pathways of Effects. Last updated December 1, 2014. Accessed December 2016 from: <http://www.dfo-mpo.gc.ca/pnw-ppe/pathways-sequences/index-eng.html>.

Fisheries and Oceans Canada (DFO). 2016a. Projects near water. Last updated November 18, 2016. Accessed December 2016 from: <http://www.dfo-mpo.gc.ca/pnw-ppe/index-eng.html>

Fisheries and Oceans Canada (DFO). 2016. Measures to avoid causing harm to fish and fish habitat including aquatic species at risk. Last updated November 18, 2016. Accessed December 2016 from: Available at: <http://www.dfo-mpo.gc.ca/pnw-ppe/measures-mesures/index-eng.html>.

AURUM ROAD PROJECT

References

January 17, 2017

- GOC. 2016. Wildlife Species Status Search: Database of wildlife species assessed by COSEWIC. Accessed December 2016 from: http://www.cosewic.gc.ca/eng/sct1/searchform_e.cfm
- Murphy, M. L., & Meehan, W. R. 1991. Stream Ecosystems. In W. R. Meehan (Ed.), Influence of forest and rangeland management on salmonid fishes and their habitats (pp. 17-46). Bethesda, Maryland, USA: American Fisheries Society Special Publication 19.
- Nelson, S.N, and M.J. Paetz. 1992. The Fishes of Alberta. 2nd Edition. The University of Alberta Press, Edmonton, Alberta.
- Schmetterling, D. A., Clancy, C. G., and Brandt, T. M. 2001. Effects of riprap bank reinforcement on stream salmonids in the western United States. *Fisheries*, 26(7), 6-13.
- Scott, W.B. and E.J. Crossman. 1998. Freshwater Fishes of Canada. 2nd Edition. Galt House Publishing Ltd. Oakville, Ontario
- Smokorowski, K.E., and Pratt, T.C. 2006. Effect of a change in physical structure and cover on fish and fish habitat. *Can. Tech. Rep. Fish. Aquat. Sci.* 2642 iv + 52 p.
- Thompson, D.M. 2002. Long-Term Effect of Instream Habitat-Improvement Structures on Channel Morphology along the Blackledge and Salmon Rivers, Connecticut, USA. *Environmental Management*. 29(1): 250-265.
- Wildlife Act Wildlife Regulation. 1997. Alberta Regulation 143/1997. With amendments up to and including Alberta Regulation 106/2016.
- Wohl, E. 2006. Human impacts to mountain streams. *Geomorphology*. 79(2006): 217-248.

AURUM ROAD PROJECT

Appendix A Engineering Design
January 17, 2017

Appendix A ENGINEERING DESIGN

AURUM ROAD PROJECT

Appendix A Engineering Design
January 17, 2017

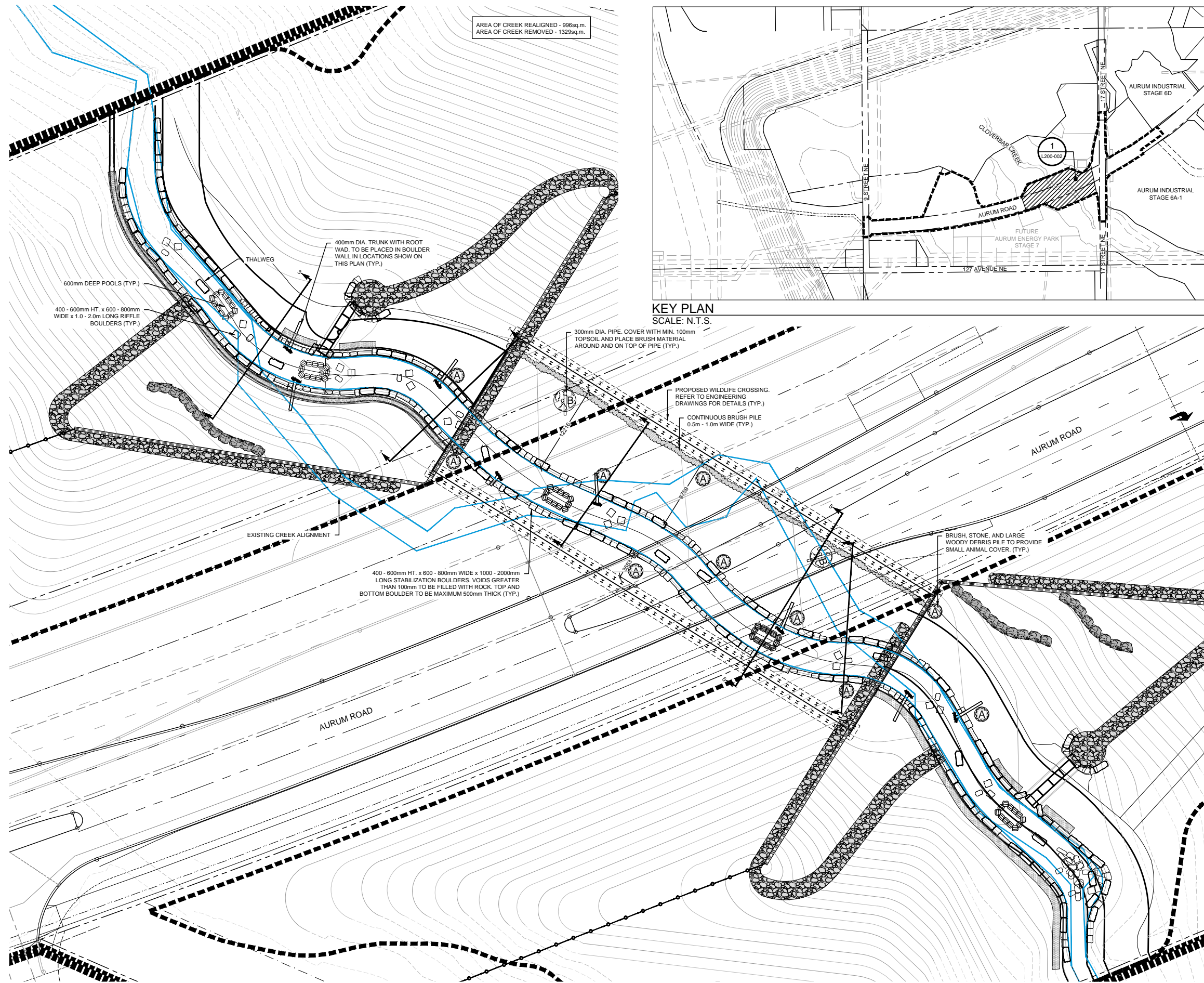

AREA OF CREEK REALIGNED - 996sq.m.
 AREA OF CREEK REMOVED - 1329sq.m.

KEY PLAN
 SCALE: N.T.S.

1 CREEK ENLARGMENT GRADING AND LAYOUT
 SCALE: 1:250



Stantec Consulting Ltd.
 10140 - 112 Street
 Edmonton AB Canada
 Tel. 780.917.7000
 www.stantec.com

Copyright Reserved
 The Contractor shall verify and be responsible for all dimensions. DO NOT scale the drawing - any errors or omissions shall be reported to Stantec without delay. The Copyrights to all designs and drawings are the property of Stantec. Reproduction or use for any purpose other than that authorized by Stantec is forbidden.

- Legend
- MANHOLE
 - LIGHT STANDARD
 - TELEPHONE / VIDEO PEDESTAL
 - TRANSFORMER
 - HYDRANT

- Notes
- UTILITY SETBACKS**
- LANDSCAPE CONTRACTOR TO CALL 'ALBERTA ONE-CALL' AT 1-800-242-3447 TO HAVE ALL EXISTING SITE UTILITIES LOCATED PRIOR TO CONSTRUCTION AND PLANT NO CLOSER THAN THE FOLLOWING DIMENSIONS FROM THE SERVICES:

1. 1.0m FROM POWER LINES
2. 3.5m FROM ALL POWER HARDWARE
3. 1.8m FROM WATER MAINS, WATER VALVES, MANUAL AIRVENTS, AND SERVICES
4. 2.0m FROM SEWER MAINS, AND MANHOLES
5. 1.8m FROM SEWER SERVICES
6. 1.5m FROM GAS (NO TREES WITHIN EASEMENT)
7. 7.5m FROM STREET CORNERS
8. 3.5m FROM FIRE HYDRANTS
9. 1.5m FROM DRIVEWAYS
10. 1.5m FROM ALLEY ACCESSSES
11. 1.0m FROM SIDEWALKS
OR AS PER APPROVED ENG. CROSS SECTIONS
12. 3.5m FROM TRANSIT ZONES
13. 3.0m FROM PRIVATE PROPERTY BOUNDARY
14. 1.25m FROM COLLECTOR ROAD CURB FACE
15. 1.25m FROM LOCAL ROAD CURB FACE
16. 2.0m FROM ARTERIAL ROAD CURB FACE
17. 3.5m FROM YIELD AND STOP SIGNS
18. 3.5m FROM BUS STOP SIGNS
19. 2.0m FROM ALL OTHER SIGNS
20. 1.0m FROM OTHER UNDERGROUND UTILITIES
21. 3.5m FROM TELUS PEDESTALS
22. 2.0m FROM TELUS DUCT STRUCTURE
23. 1.0m FROM TELUS CABLE FACILITIES

LANDSCAPE CONTRACTOR IS RESPONSIBLE FOR DAMAGES AND LIABILITIES INCURRED BY DAMAGES TO SITE UTILITIES.

Development Engineer, Sustainable Development			
Approvals			YYMM.DD
Revision	By	Appd.	YYMM.DD
1ST ISSUE FOR REVIEW	KW/KH/CB	DP	17.01.13
Issued	By	Appd.	YYMM.DD
File Name: L:\AurumRoad_Stage6A-1.dwg	Dwn.	Chkd.	Dign.
			YYMM.DD

Permit-Seal



David A. Price

Client/Project
 AURUM INDUSTRIAL
 DEVELOPMENT PARTNERSHIP
 AURUM ROAD
 17 STREET NE TO 9 STREET NE
 Edmonton, AB

Title
 CREEK AND RAVINE RESTORATION
 CREEK ENLARGMENT GRADING AND
 LAYOUT

Project No. 1161-104130 Scale 0 2.5 5 7.5 10 12.5

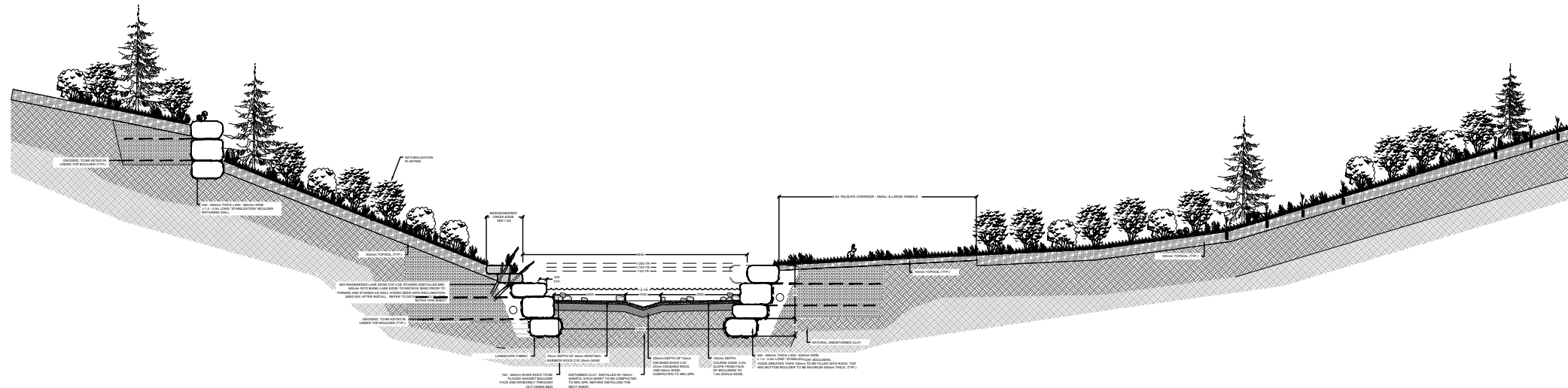

1 SECTION 3 - RUN NATURALIZED
SCALE: 1:75

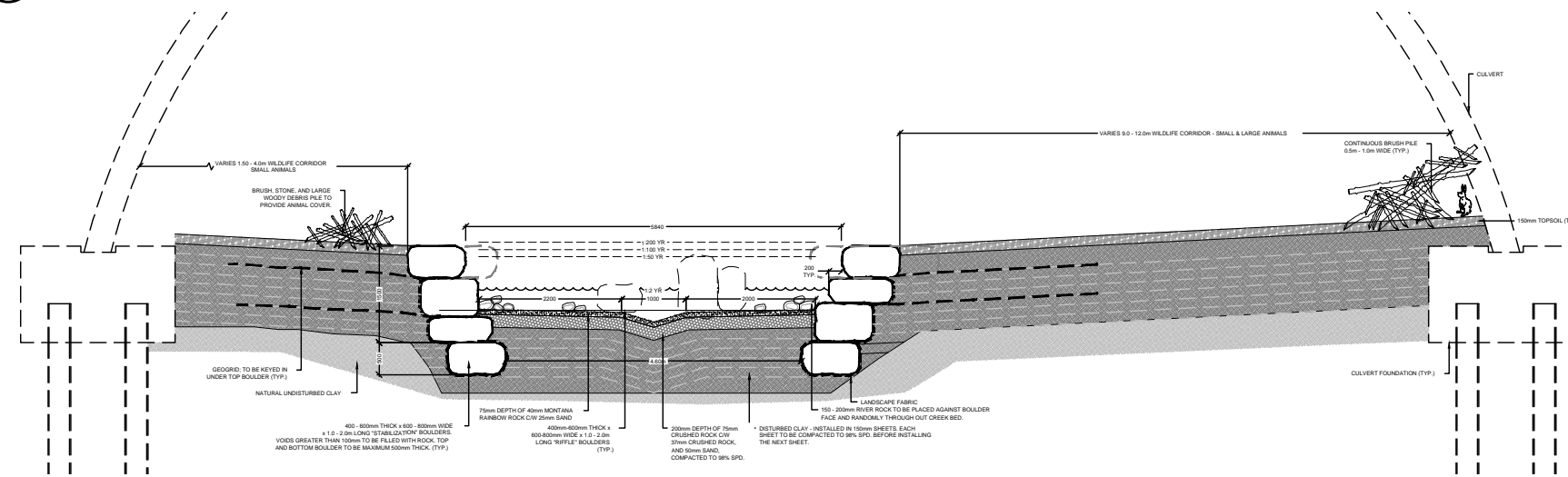

2 SECTION 2 - RIFFLE CHANNELIZED
SCALE: 1:50

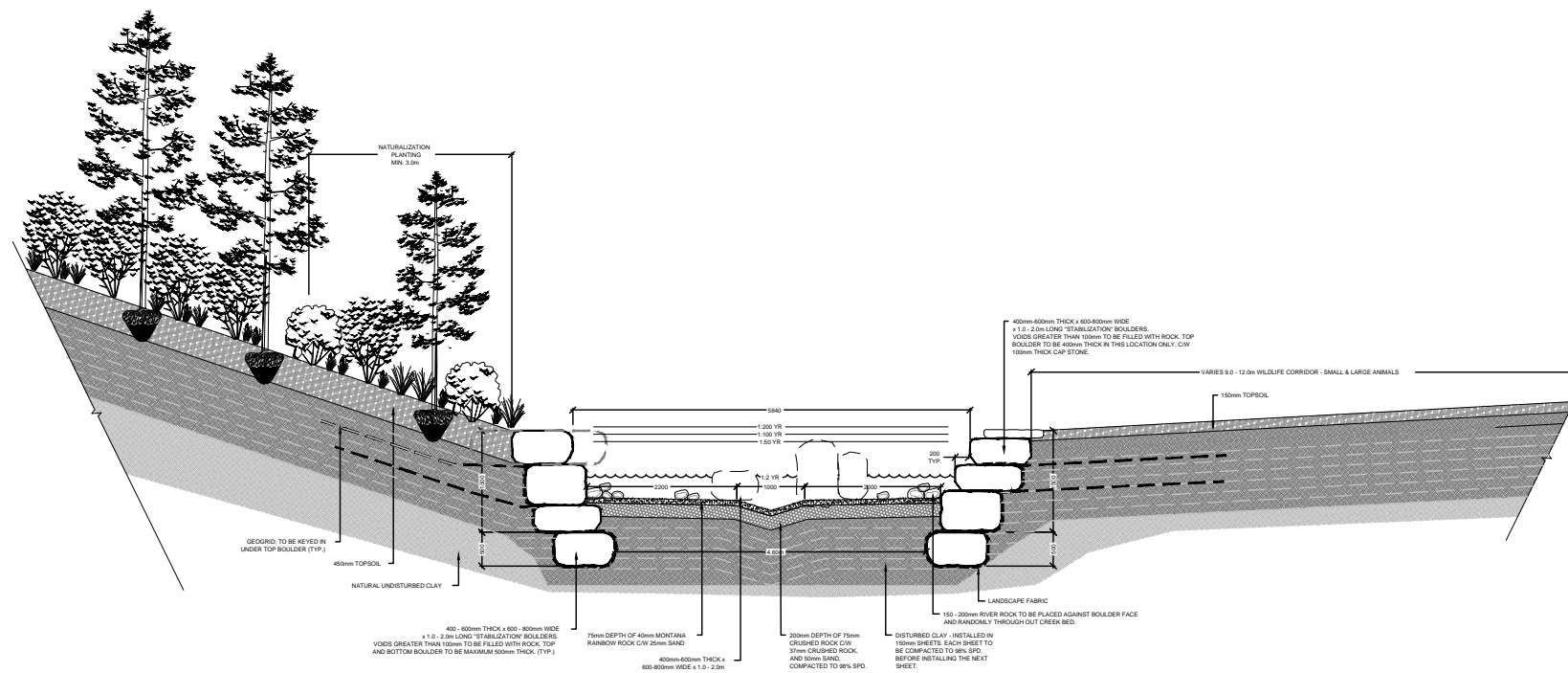

3 SECTION 1 - RUN NATURALIZED
SCALE: 1:50



Stantec Consulting Ltd.
10140 - 112 Street
Edmonton AB Canada
Tel. 780.917.7000
www.stantec.com

Copyright Reserved

The Contractor shall verify and be responsible for all dimensions. DO NOT scale the drawing - any errors or omissions shall be reported to Stantec without delay. The Copyrights to all designs and drawings are the property of Stantec. Reproduction or use for any purpose other than that authorized by Stantec is forbidden.

Legend

Notes

Development Engineer: Sustainable Development			
Approvals			YYMM.DD
Revision	By	Appd.	YYMM.DD
1ST ISSUE FOR REVIEW	KW/KH/CB	DP	17.01.13
Issued	By	Appd.	YYMM.DD
File Name: LA_AurumRoad_SiteRestoration.dwg	Dwn.	Chkd.	Dign.
			YYMM.DD

Permit-Seal



David A. Price

Client/Project
AURUM INDUSTRIAL
DEVELOPMENT PARTNERSHIP
AURUM ROAD
17 STREET NE TO 9 STREET NE
Edmonton, AB

Title
CREEK AND RAVINE RESTORATION
CROSS SECTION DETAILS

Project No. 1161-104130 Scale AS SHOWN

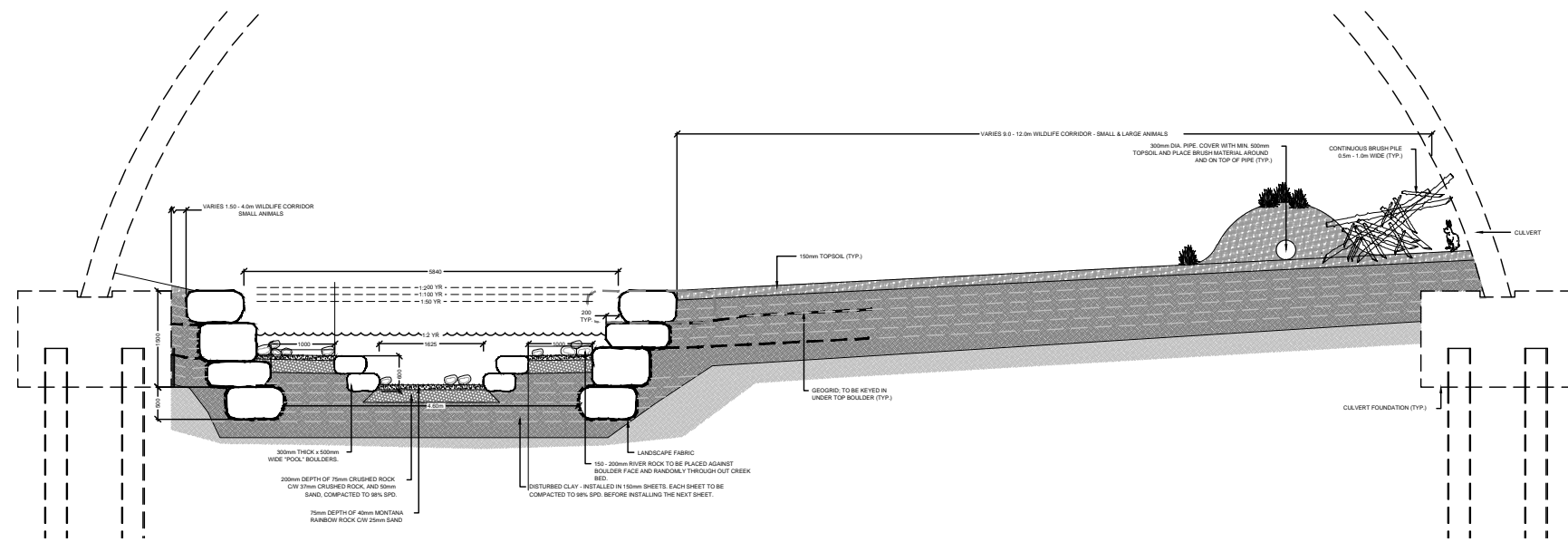

1 SECTION 5 - RIFFLE CHANNELIZED
SCALE: 1:50

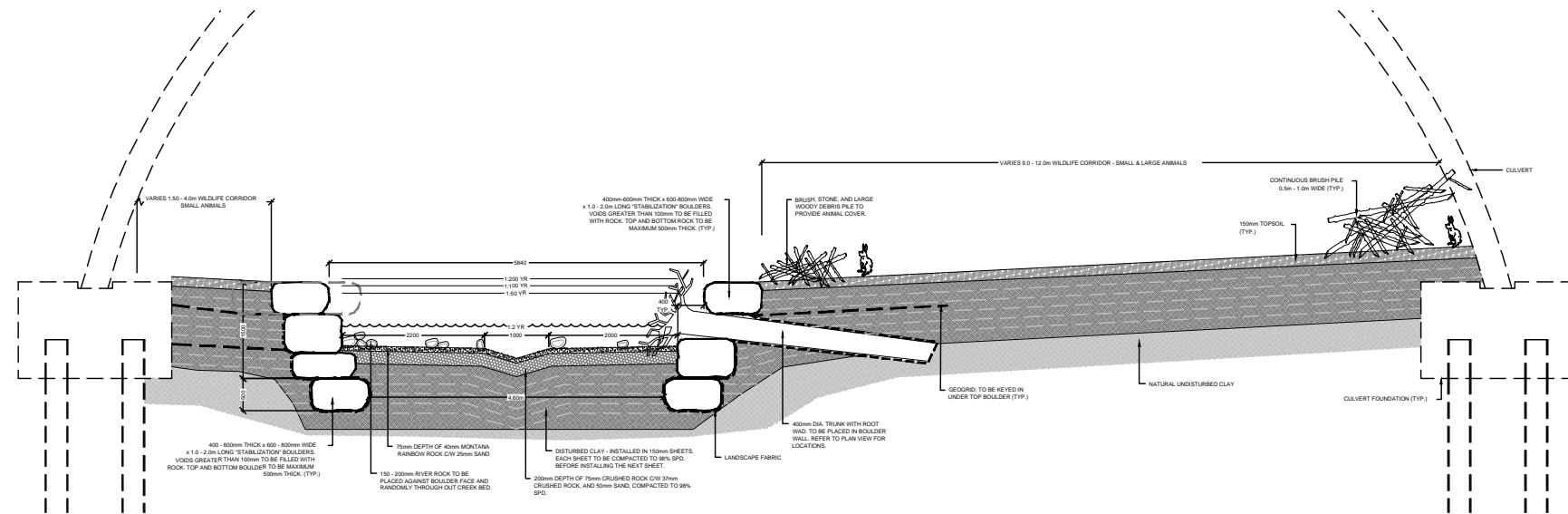

2 SECTION 4 - RIFFLE CHANNELIZED
SCALE: 1:50

3 BRUSH LAYERING INSTALLATION
SCALE: 1:50



Stantec Consulting Ltd.
10140 - 112 Street
Edmonton AB Canada
Tel. 780.917.7000
www.stantec.com

Copyright Reserved

The Contractor shall verify and be responsible for all dimensions. DO NOT scale the drawing - any errors or omissions shall be reported to Stantec without delay. The Copyrights to all designs and drawings are the property of Stantec. Reproduction or use for any purpose other than that authorized by Stantec is forbidden.

Legend

Notes

Development Engineer, Sustainable Development			
Approvals			YYMM.DD
Revision	By	Appd.	YYMM.DD
1ST ISSUE FOR REVIEW	KW/KH/CB	DP	17.01.13
Issued	By	Appd.	YYMM.DD
File Name:	LA_AurumRoad_BioRetention.dwg	Dwn.	Chkd.
		Dgn.	YYMM.DD

Permit-Seal



David A. Price

Client/Project
AURUM INDUSTRIAL
DEVELOPMENT PARTNERSHIP
AURUM ROAD
17 STREET NE TO 9 STREET NE
Edmonton, AB

Title
CREEK AND RAVINE ALIGNMENT
CROSS SECTION DETAILS

Project No. 1161-104130 Scale AS SHOWN

Drawing No. L200-010
10 of 11

Aurum Industrial Development Partnership Creek Realignment Concept Plan



SURVEY BY

- STANTEC CONSULTING LTD., UNDER THE DIRECTION OF KYLE SAHURI, JUNE 17, 2016.
- ELEVATIONS ARE GEODETIC AND ARE DERIVED FROM ALBERTA SURVEY CONTROL MARKER 374819 (ELEVATION = 651.242)

HYDROTECHNICAL DATA

- DRAINAGE AREA = 20.5 km² (PROVIDED BY OTHERS)
- DESIGN DISCHARGE = 11.9 m³/s
- MEAN OUTLET VELOCITY AT PROPOSED CULVERT FOR DESIGN DISCHARGE = 2.3 m/s
- AVERAGE SURVEYED CHANNEL SLOPE = 0.014 m/m

PROPOSED STRUCTURES

- 21.5 WIDE x 8.0 RISE x 66.0 m INVERT LENGTH ARCH CULVERT

CITY OF EDMONTON APPROVAL
STAMP LOCATION



Stantec Consulting Ltd.
10160 - 112 Street
Edmonton AB Canada
Tel. 780.917.7000
www.stantec.com

Copyright Reserved

The Contractor shall verify and be responsible for all dimensions. DO NOT scale the drawing - any errors or omissions shall be reported to Stantec without delay. The Copyrights to all designs and drawings are the property of Stantec. Reproduction or use for any purpose other than that authorized by Stantec is forbidden.

Legend

FENCE LINES	
BUSH LINES	
BOREHOLES	

Notes

- DIMENSIONS ARE GIVEN IN METRES UNLESS NOTED OTHERWISE
- APPROXIMATE DISTANCE ACROSS THE RAVINE AT EL 648.0 = 150.0 m ±
- ROADWAY DESIGN STANDARD CITY OF EDMONTON DESIGN AND CONSTRUCTION STANDARDS, VOLUME 2 ROADWAYS, MAY 2015
- STANDARD URBAN ARTERIAL ROAD
- DESIGN SPEED 70 km/h

	RE-ALIGNED CREEK		HABITAT PLANTING
	WILDLIFE CORRIDOR: SMALL AND LARGE ANIMALS		NON-HABITAT PLANTING
	WILDLIFE CORRIDOR: SMALL ANIMALS		GRASSED SLOPE
	RIP RAP SWALE		RETAINING WALL
	ADDITIONAL ARMOURING		BOX CULVERT
	ACCESS ROAD		WILDLIFE FENCING

Revision

By	Appd.	YY.MM

Issued

By	Appd.	YY.MM

PROJECT MANAGER: — DESIGN: SW DRAWN: EC

Permit-Seal

Client/Project

AURUM INDUSTRIAL
DEVELOPMENT PARTNERSHIP

AURUM ROAD
N. OF 127 AVENUE, W. OF 17 STREET
EDMONTON, AB

Title

AURUM INDUSTRIAL
35° SKEW CULVERT - GENERAL LAYOUT

Project No.
1161104130

Scale 0 5 15 25m
1:500

Drawing No.

S001-001

2016-10-20 10:21am BR/CLAY



S.E. 1/4 SEC. 21,
TWP. 53, RGE. 23, W.4 MER.

PLAN
1:500

BH10 (2011)

EXISTING 900 mm DIA CSP
INV = 635.11

R/W PLAN 3667 M.C.

17 STREET N.E.

GOVERNMENT ROAD ALLOWANCE

Aurum Industrial Development Partnership

Creek Realignment

Candidate Plant Species

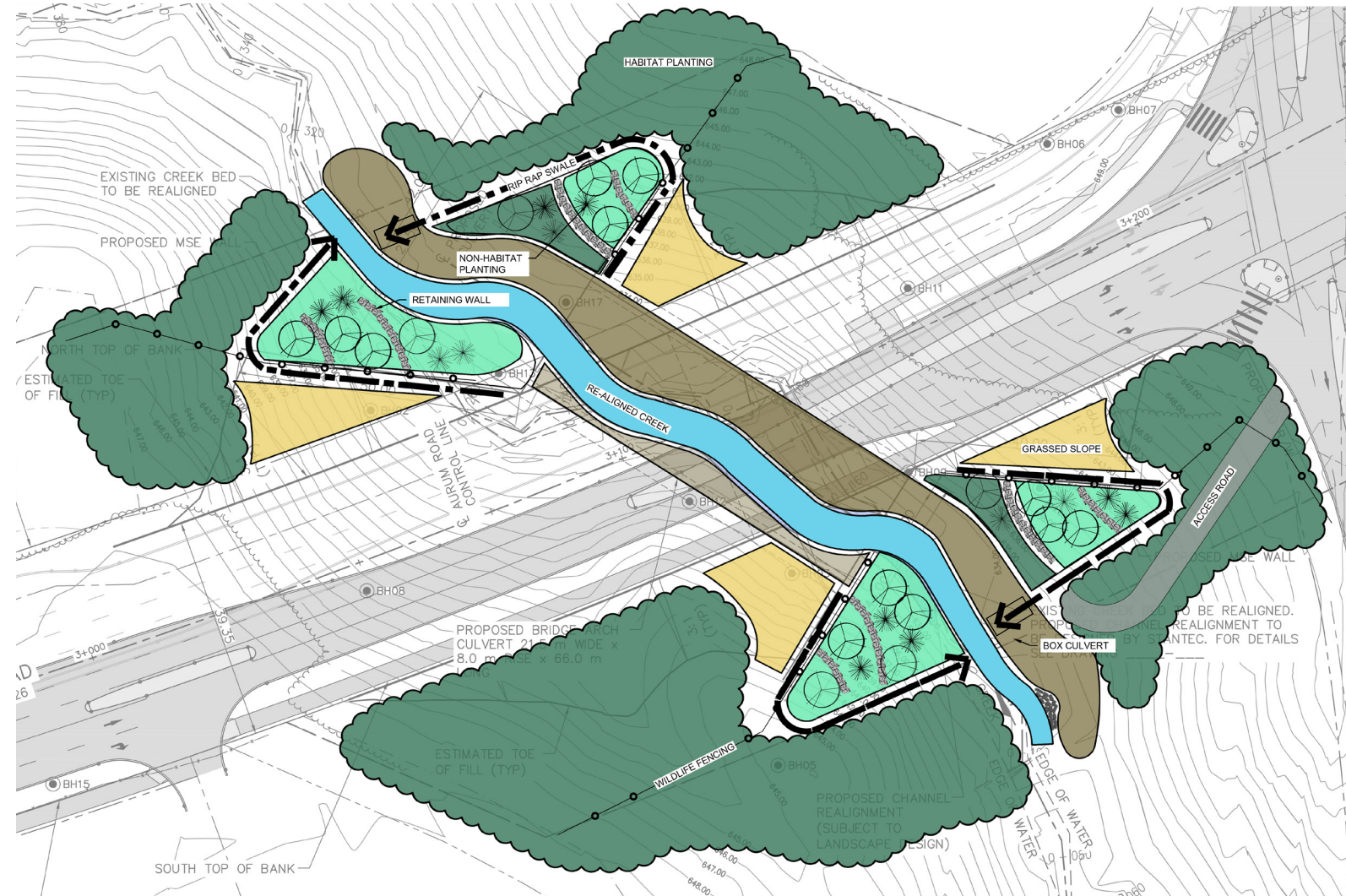

Populus tremuloides
Trembling Aspen



Picea glauca
White Spruce



Salix discolor
Pussy Willow



Salix bebbiana



Betula papyrifera
Paper Birch

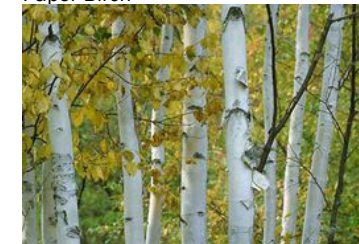

Viburnum opulus
Highbush Cranberry



Lonicera involucrata
Bracted Honeysuckle



Symphoricarpos occidentalis
Western Snowberry



Larix laricina
Tamarack



TREES

Betula papyrifera
Larix laricina
Populus balsamifera
Populus tremuloides
Picea glauca
Pinus banksiana
Salix macalliana
Prunus pennsylvanica
Prunus virginiana

SHRUBS

White Birch
Tamarack
Balsam Poplar
Trembling Aspen
White Spruce
Jack Pine
Velvet-fruited Willow
Pin Cherry
Common Chokecherry

Cornus sericea spp. *sericea*
Corylus cornuta
Lonicera involucrata
Ribes oxycanthoides
Rosa acicularis
Salix bebbiana
Salix discolor
Salix exigua
Symphoricarpos occidentalis
Viburnum edule
Viburnum opulus

Red Osier Dogwood
Beaked Hazelnut
Bracted Honeysuckle
Northern Gooseberry
Prickly Wild Rose
Bebb's Willow
Pussy Willow
Sandbar Willow
Western Snowberry
Lowbush Cranberry
Highbush Cranberry

GRASSES / SEDGES

Agropyron dasystachyum
Bromus ciliatus
Calamagrostis canadensis
Carex bebbii
Agropyron trachycaulus
Nassella viridula
Scirpus microcarpus

Agropyron smithii
Beckmania syzigachne
Elymus pipuri syn. *Cinereus*
Lolium multiflorum
Deschampsia cespitosa
Poa palustris

Northern wheatgrass
Fringed Bromegrass
Bluejoint grass
Bebb's sedge
Slender Wheatgrass
Green Needlegrass
Small-fruited bullrush

Western Wheatgrass
Slough Grass
Giant Wild Rye
Annual Ryegrass
Tufted Hairgrass
Fowl Bluegrass

Cornus sericea spp. *sericea*
Red Osier Dogwood



Ribes oxycanthoides
Northern Gooseberry



Rosa acicularis
Prickly Wild Rose



AURUM ROAD PROJECT

Appendix B Site photos
January 17, 2017

Appendix B SITE PHOTOS



Photo B-1 View upstream at the proposed crossing location (July 13, 2016)



Photo B-2 View downstream at the proposed crossing location (July 13, 2016)

AURUM ROAD PROJECT

Appendix B Site photos
January 17, 2017



Photo B-3 View of right downstream bank at the proposed crossing location
(July 13, 2016)



Photo B-4 View of left downstream banks at the proposed crossing location
(July 13, 2016)

AURUM ROAD PROJECT

Appendix B Site photos
January 17, 2017



Photo B-5 View upstream at 200 m downstream of the proposed crossing location
(July 13, 2016)



Photo B-6 View downstream at 100 m upstream of the proposed crossing location
(July 13, 2016)

AURUM ROAD PROJECT

Appendix B Site photos
January 17, 2017

Appendix C PATHWAYS OF EFFECTS

C.1 VEGETATION CLEARING (RIPARIAN)

Summary

Clearing of upland and riparian vegetation (i.e., crown closure) can increase the amount of light reaching the stream, increasing primary productivity. This increase in productivity can be beneficial; however, the removal of vegetation can also increase stream temperature to the detriment of fish (Murphy & Meehan, 1991). The permanent loss of vegetation is detrimental because it is a loss of natural habitat-forming material, overhead cover, and shade (Thompson 2002). Vegetation clearing can also decrease the stability of soils, which can lead to increase erosion and sediment inputs to a water body.

These impacts are typically mitigated by implementing the standard measures and mitigations to minimize vegetation removal and encourage re-growth.

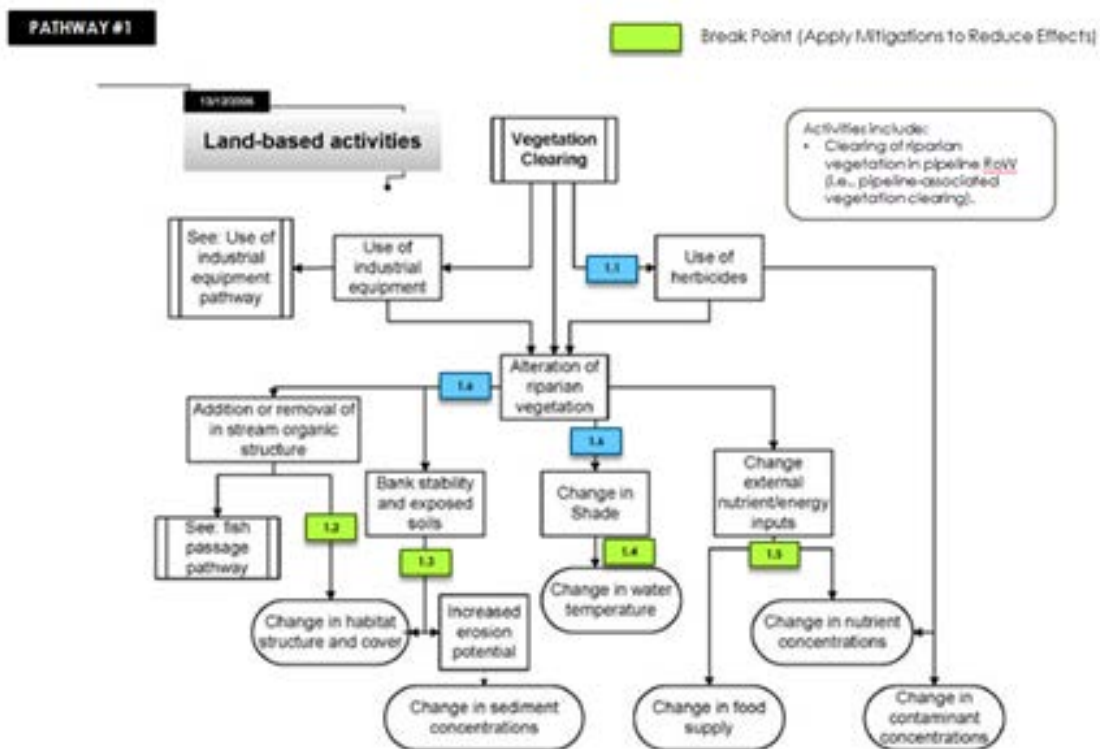

C.2 RIPARIAN PLANTING

Summary

Planting of riparian vegetation adjacent to a water body/ watercourse is typically associated with reclamation of areas disturbed by various construction activities including riparian vegetation removal, culvert construction, or temporary vehicle crossings. Riparian planting may involve the use of fertilizers, site preparation methods, and the introduction of native and non-native plant species.

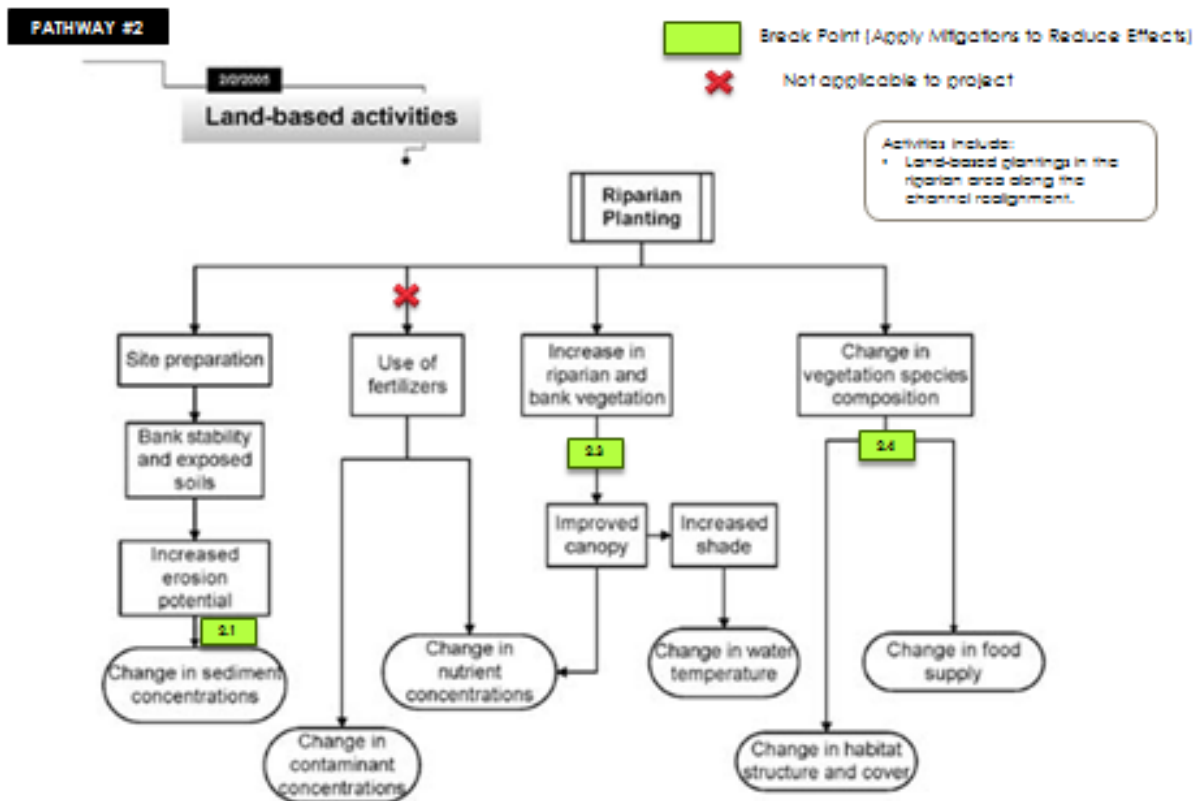

C.3 GRADING

Summary

Grading the watercourse crossing right of way and construction approaches temporarily modifies the drainage pattern and could result in an increase of sediment transportation into the watercourse. Grading does not include excavation of the trench. These impacts are typically mitigated by the use of sediment and erosion control measures, timely reclamation, and other applicable standard measures and mitigations that minimize vegetation removal and encourage re-growth.

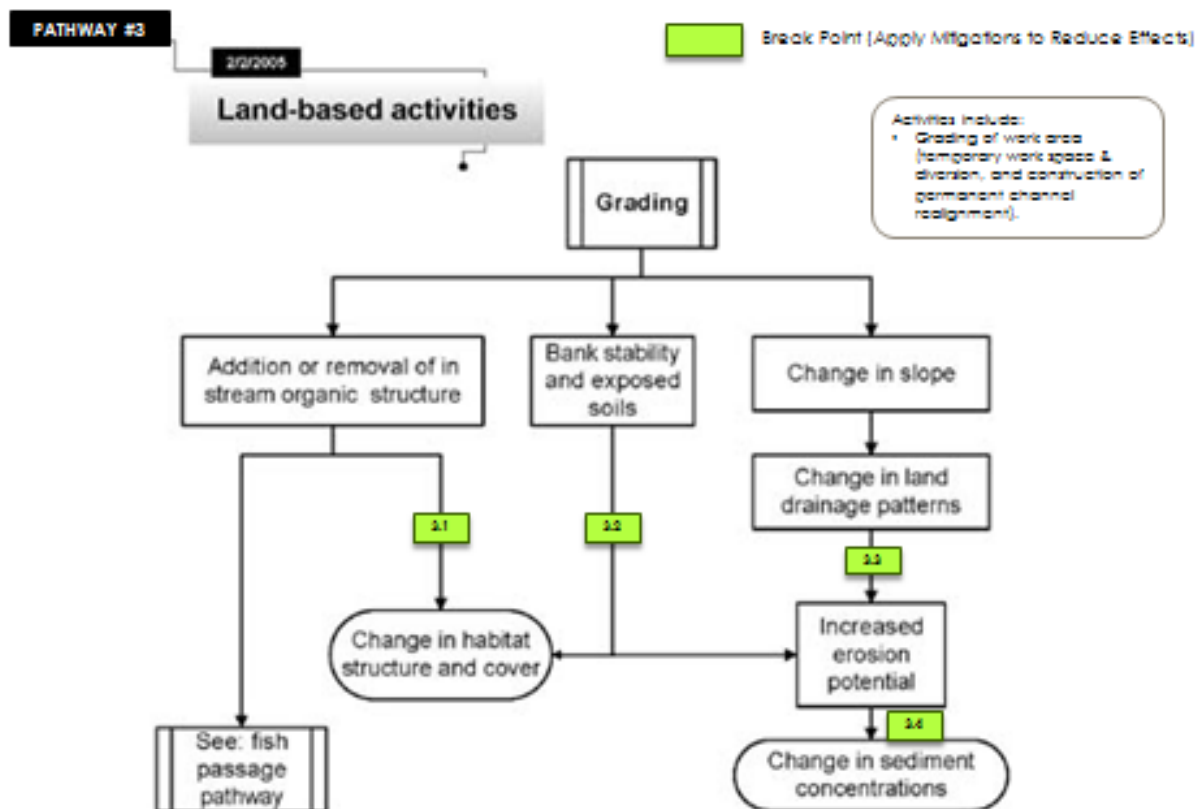

C.4 EXCAVATION

Summary

Open excavations on an upland slope or in the riparian area can alter the habitat at the site, alter subsurface flows, and increase the mobilization of sediments. These impacts can be mitigated by site selection, the use of sediment and erosion control measures, timely reclamation, and other standard measures and mitigations that minimize vegetation removal and encourage re-growth.

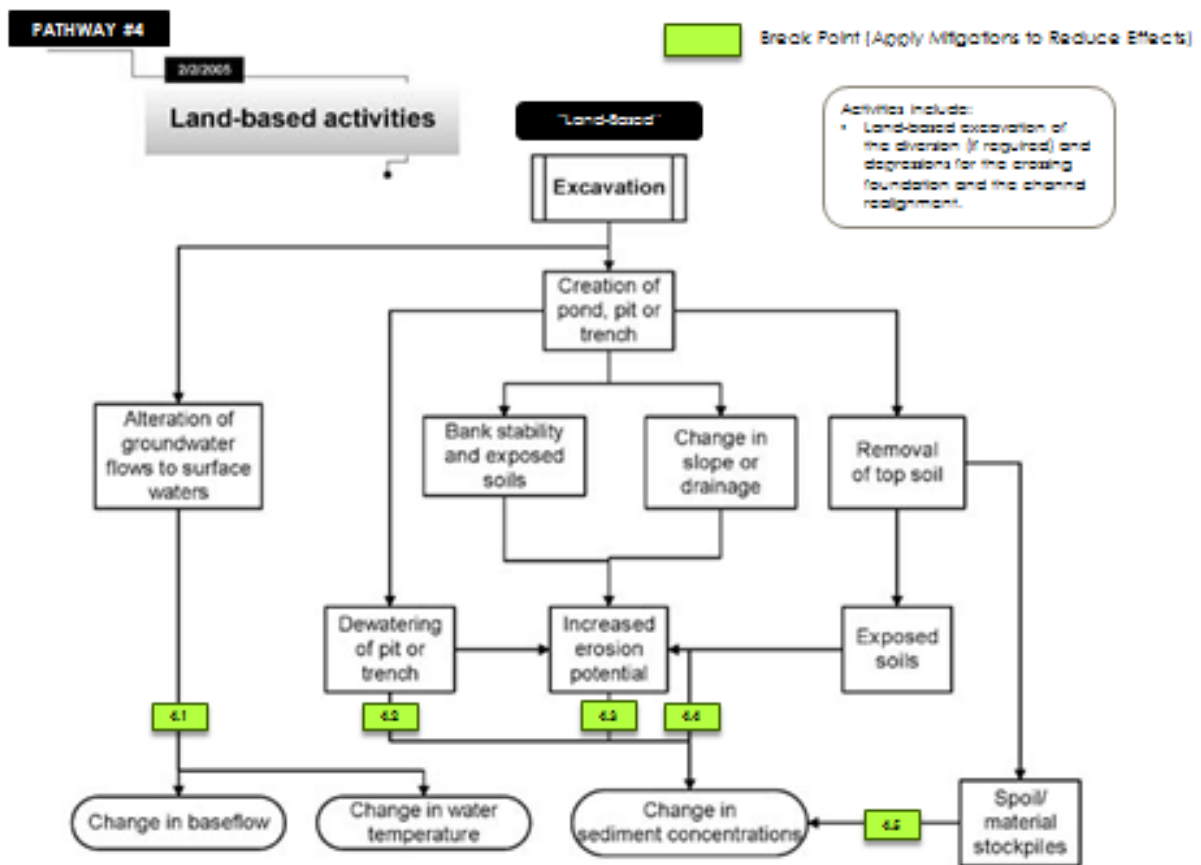

C.5 USE OF EXPLOSIVES

Summary

The use of explosives can affect fish and habitat, resulting in un-mitigatable damage and mortality. The use of explosives outside of DFO's Measures to Avoid Causing Harm to Fish and Fish Habitat Including Aquatic Species at Risk (2016b) should be submitted for crossing-specific review.

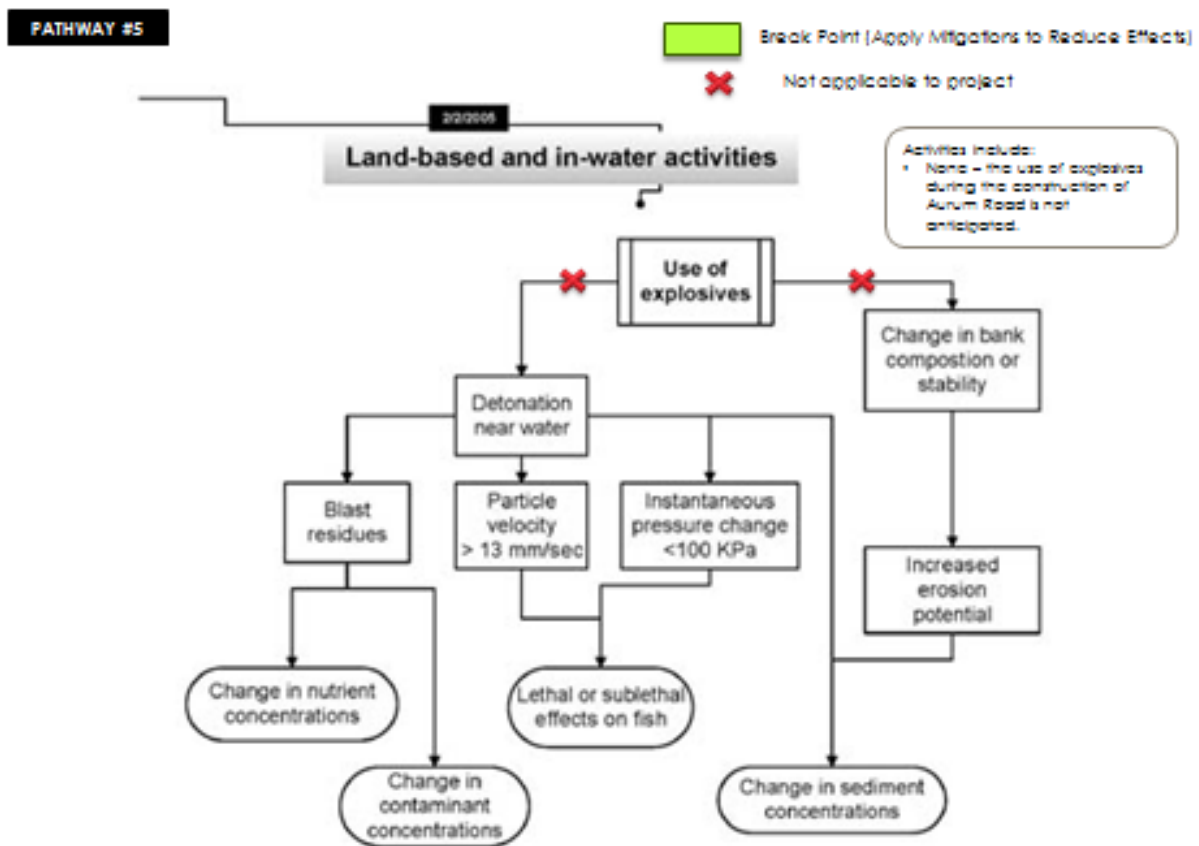

C.6 USE OF INDUSTRIAL EQUIPMENT

Summary

The operation of machinery in and around water can cause the direct mortality of fish, introduce contaminants, disturb the bed and banks, and mobilize sediment.

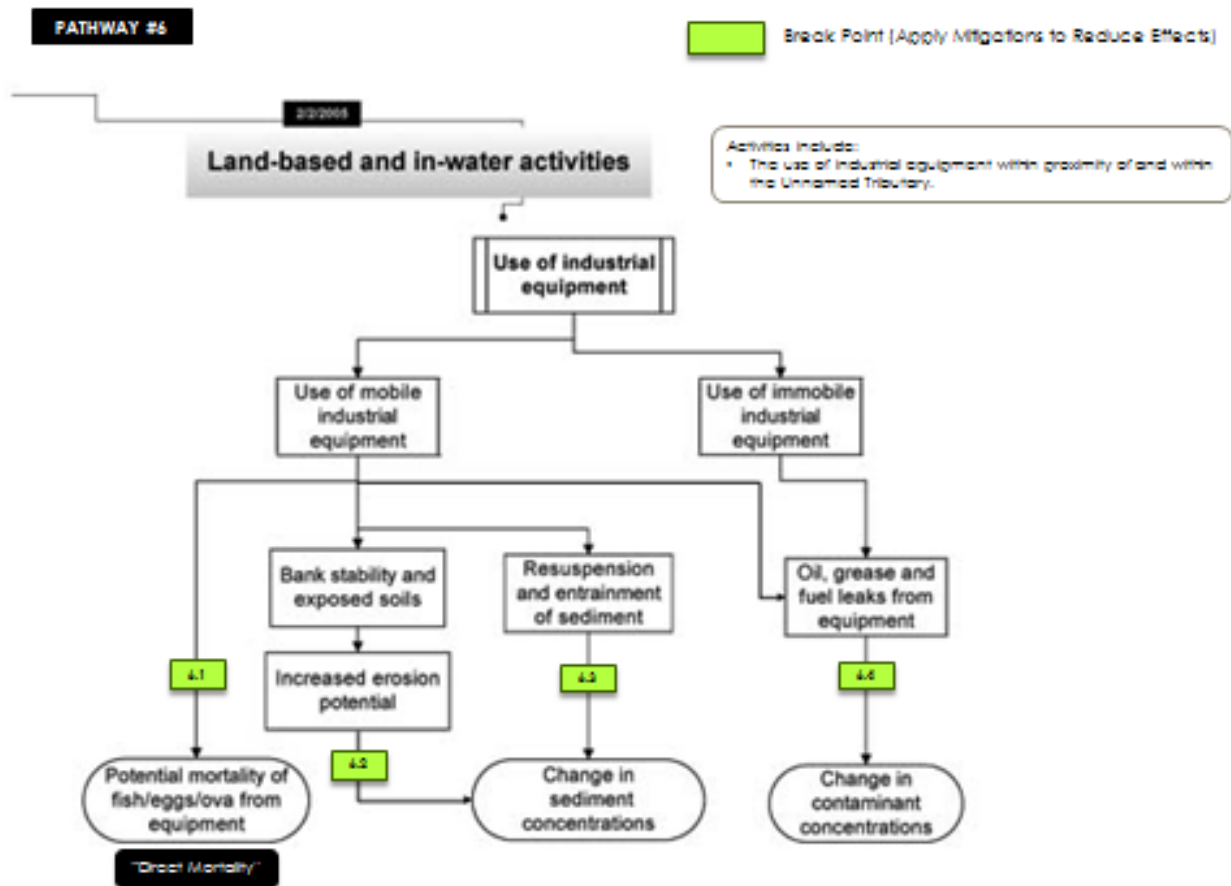

C.7 PLACEMENT OF MATERIAL OR STRUCTURES IN WATER

Summary

Structures placed in the watercourse can backup water causing flooding, alter the habitat at the site, alter water velocities around the structure, impede fish passage, and increase the mobilization of sediments. These impacts can be mitigated by site selection, structure design, the use of sediment and erosion control measures, timely reclamation, and other standard measures and mitigation that minimize vegetation removal and encourage re-growth. Residual effects are generally considered to be negligible if standard measures and mitigations are implemented.

The placement of rock armour or riprap is a commonly used method to reduce bank erosion. The spaces between the rock may provide cover for small fish and reduce sediment mobilized by erosion; however, overall, riprap prevents natural stream process and limits the habitat provided (Schmetterling et al. 2001). Small site-specific activities may reduce localized negative erosion effects to streambanks, but may not effectively reduce cumulative effects in a watershed. The impacts of bank stabilization can be mitigated by the inclusion of complex habitat features, such as woody debris and the use of "soft-engineering" and vegetation. Due to the small footprint of the watercourse crossing right-of-way and standard measures and mitigation, residual effects resulting from bank stabilization are generally considered negligible.

Changes in channel morphology might occur from increased flows associated with the isolation bypass measures and physical alterations to the channel features (i.e., bed and banks, width, depth, and gradient) associated with the excavation of materials required to re-align the channel. Resultant decreases in habitat complexity are detrimental to fish diversity and may change species composition (Smokorowski and Pratt 2006).

AURUM ROAD PROJECT

Appendix C Pathways of Effects
January 17, 2017

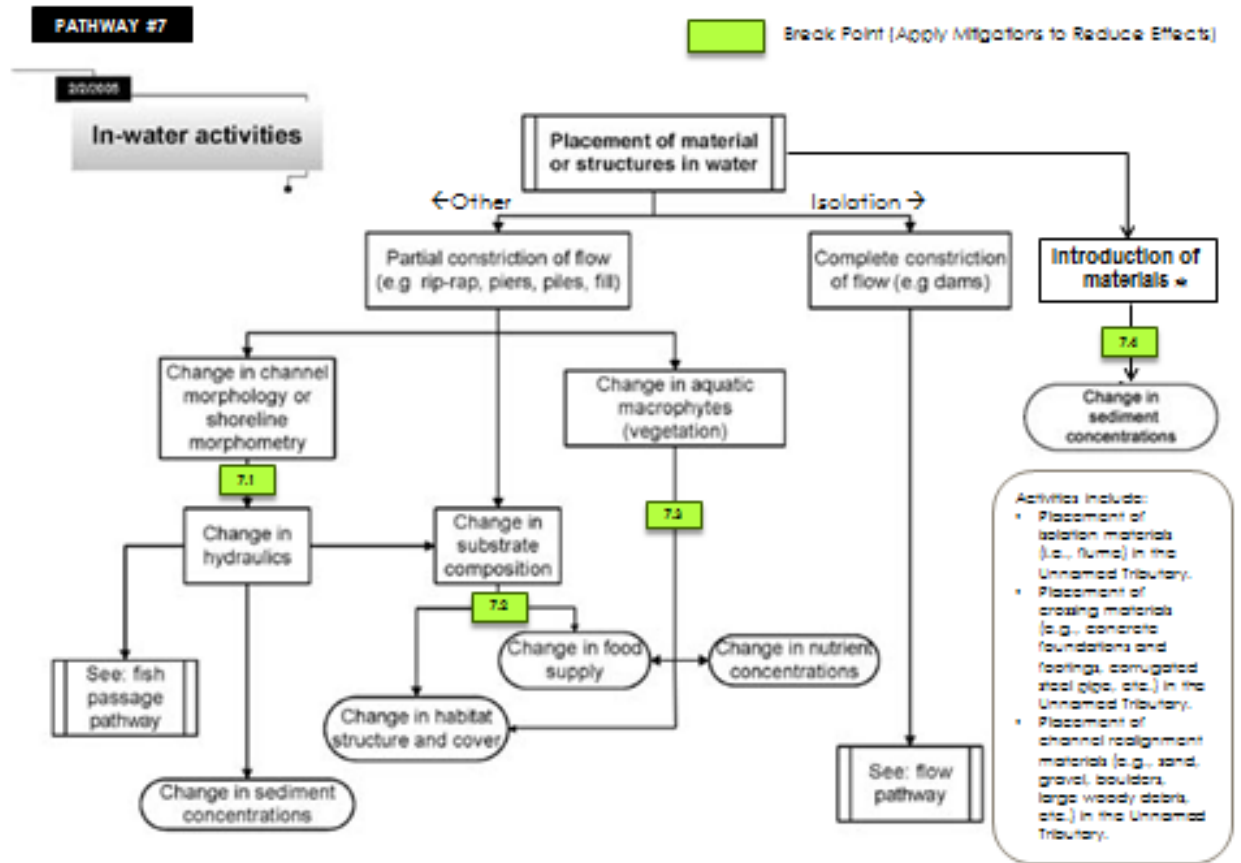

C.8 DREDGING (INSTREAM EXCAVATION)

Summary

Excavations in the streambed can alter the habitat at the site, alter subsurface flows, and increase the mobilization of sediments. If the habitat is limiting, or rare in the system, there is a possibility that the habitat cannot be reclaimed back to a similarly functioning pre-construction condition. These impacts are typically mitigated by site selection, timing, the use of sediment and erosion control measures, and other standard measures and mitigation that minimize vegetation removal and encourage re-growth.

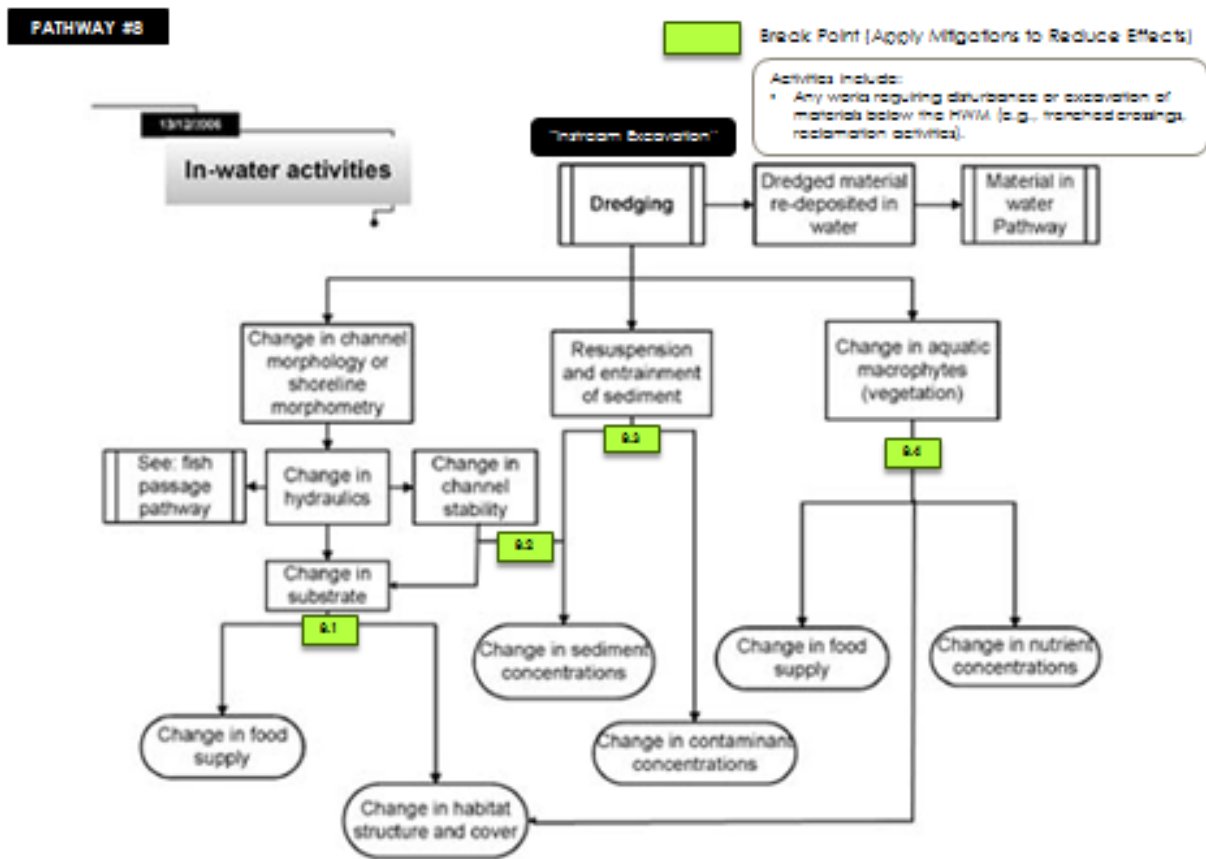

C.9 STRUCTURE REMOVAL

Summary

The structure removal PoE applies to the manual or mechanical removal of non-natural temporary construction materials introduced during culvert and associated construction works including, but not limited to: isolation materials, bridge abutments and culverts (temporary), geotextile fabric, and/or temporary fill materials.

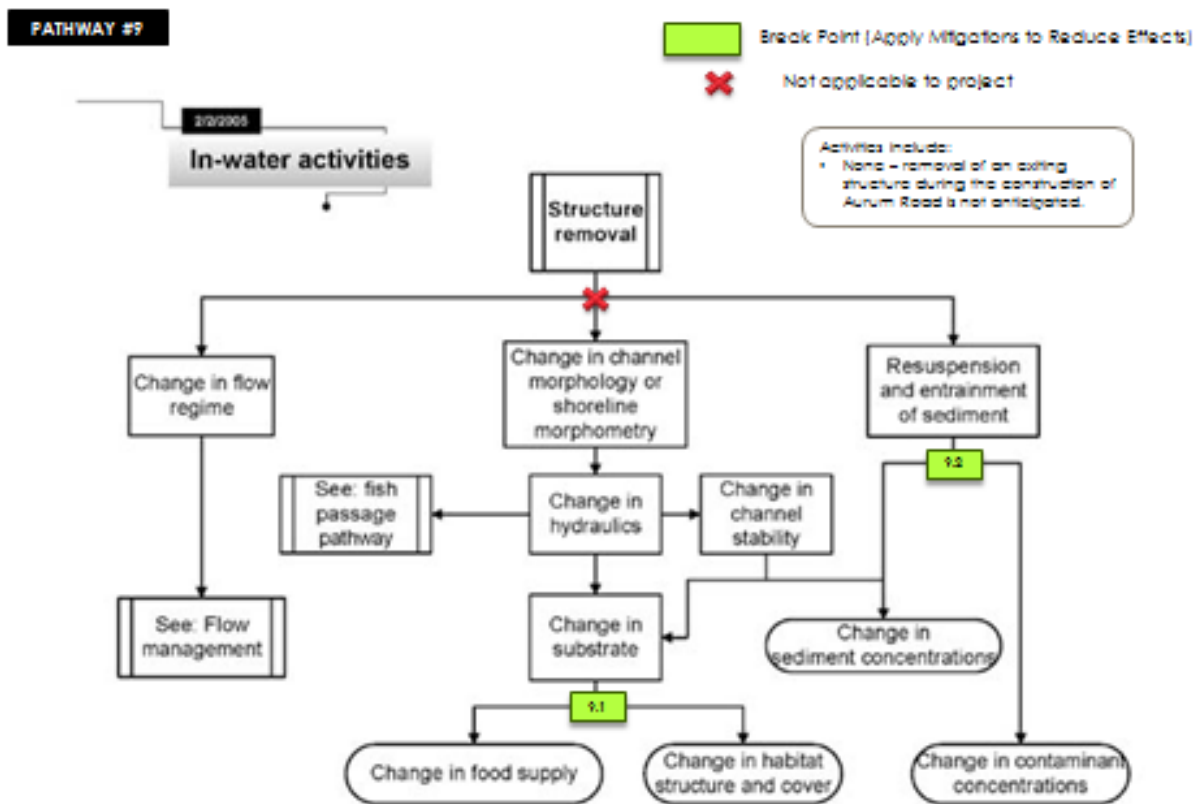

C.10 WATER EXTRACTION

Summary

Water extraction can be used during the construction of temporary crossings such as ice bridges, during hydrostatic testing, and dewatering. Pumping from a watercourse can alter downstream flows, kill fish in the pumps, and impinge fish on screens. Pumping can also impact overwintering fish habitat by reducing water quantity and quality (i.e., oxygen levels). These impacts are typically mitigated by site selection, timing, the use of sediment and erosion control measures, DFO's Freshwater Intake End-of-Pipe Fish Screen Guidelines (DFO 1995) and other standard measures and mitigation. Residual effects are generally considered to be negligible if standard measures and mitigations are implemented.

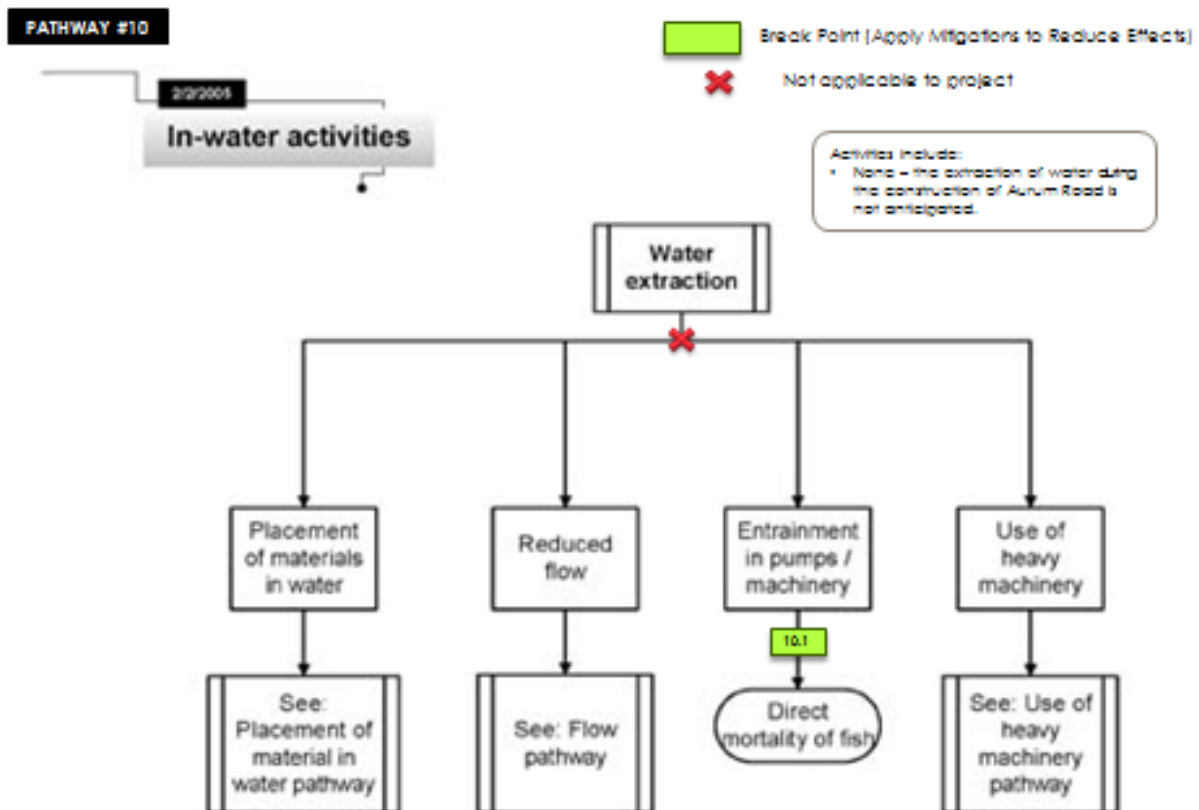

C.11 FISH PASSAGE ISSUES

Summary

Impeding migration in fish populations by preventing the normal movement between feeding, rearing, overwintering, and spawning areas can cause serious harm to a fishery, as many aquatic organisms rely on the ability to move upstream or down to complete their lifecycles (Wohl 2006).

Changing flow or temporarily obstructing the river can affect fish movement and migration past the site. Fish movement can also be disrupted directly through instream activities and construction near the watercourse, or indirectly through sediment releases, noise, movement, and vibrations from equipment on site.

Isolation measures can affect fish populations by disrupting migration past the construction site or completely blocking migration in the watercourse. Fish movements and migrations can be disrupted directly through instream construction activities and isolation measures creating high water velocities, or indirectly by increasing adjacent water velocities and increasing sediment concentrations.

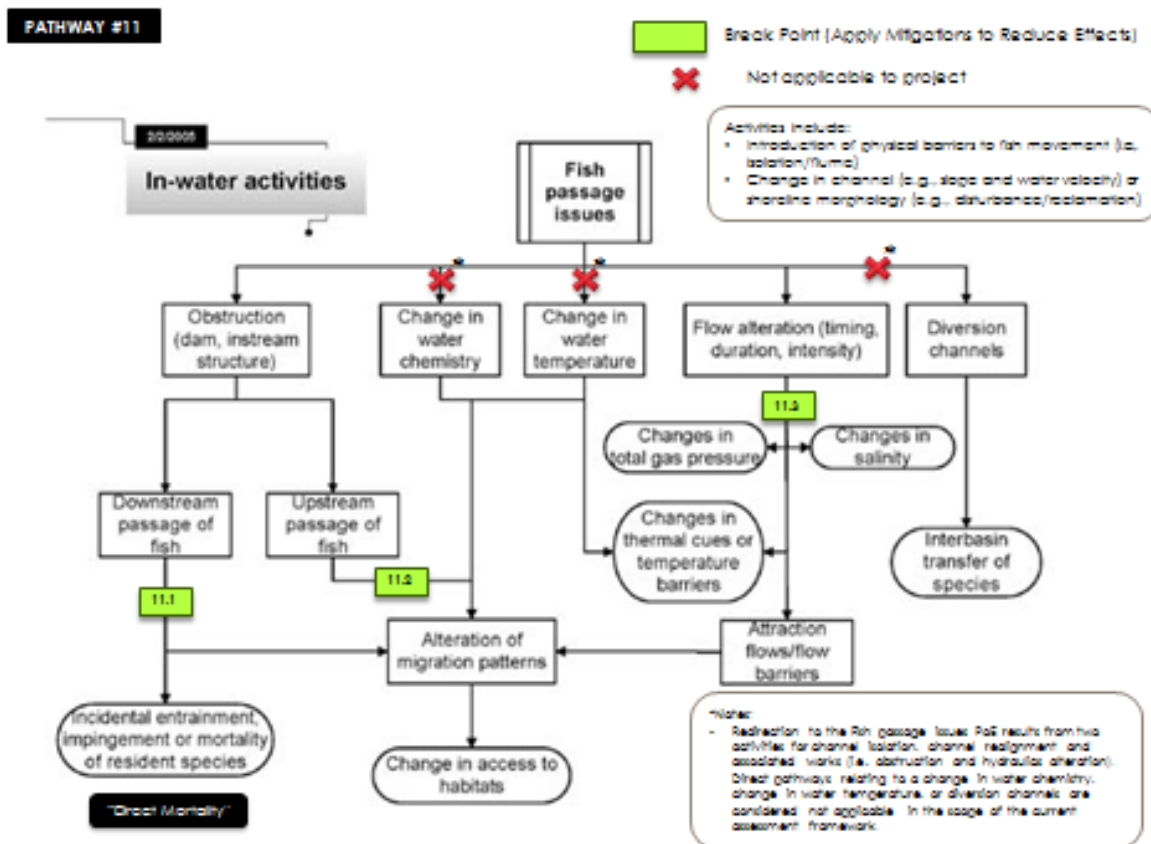

C.12 CHANGE IN TIMING, DURATION AND FREQUENCY OF FLOW

Summary

Changes to the local hydraulics of a watercourse and changes to subsurface flows can disrupt the use of spawning and overwintering habitats, change how sediment is mobilized, impede fish movement, and directly alter the structure of habitat at the site, including an increase in local erosion of the bed and banks.

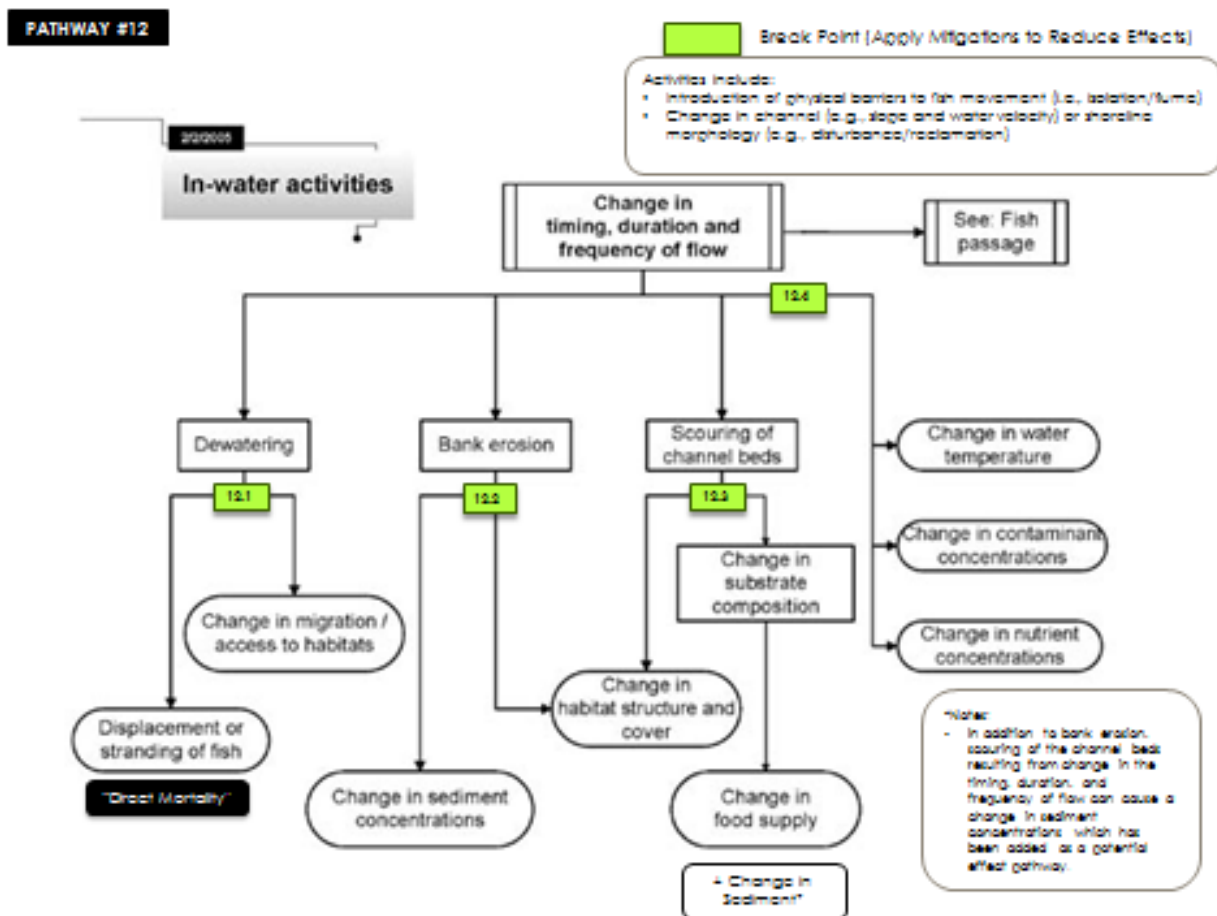

APPENDIX E
GEO TECHNICAL REPORT

Geotechnical Investigation Report

Aurum Road Creek Crossing



Prepared for:
Aurum Industrial Development
Partnership

Prepared by:
Stantec Consulting Ltd.

February 24, 2017

Table of Contents

1.0	INTRODUCTION	1
1.1	SCOPE OF WORK	2
1.2	SITE AND PROJECT DESCRIPTION	2
2.0	METHODOLOGY	4
2.1	DESKTOP REVIEW	4
2.1.1	Site Reconnaissance	4
2.1.2	Geological Review	4
2.1.3	Available Geotechnical Reports.....	5
2.1.4	Aerial Photograph Review	5
2.1.5	Coal Mining Activity	5
2.2	FIELD DRILLING PROGRAM	6
2.3	LABORATORY TESTING	6
3.0	SUBSURFACE CONDITIONS	7
3.1	ROAD ALIGNMENT	7
3.1.1	Topsoil.....	7
3.1.2	Clay Till (CI-CH)	7
3.1.3	Bedrock.....	8
3.2	POND AND BORROW AREA	8
3.2.1	Topsoil.....	8
3.2.2	Clay Till (CI)	9
3.2.3	Sand	9
3.3	LIFT STATION	9
3.3.1	Topsoil.....	9
3.3.2	Clay Till (CI)	10
3.3.3	Sand	10
3.3.4	Bedrock.....	11
3.4	CULVERT AND CREEK AREA	11
3.4.1	Topsoil.....	12
3.4.2	Clay Till (CH)	12
3.4.3	Sand	13
3.4.4	Clay Colluvium.....	13
3.4.5	Sand (SP)	13
3.4.6	Sand and Gravel	14
3.4.7	Bedrock.....	14
3.5	SUMMARIZED UNCONFINED COMPRESSIVE STRENGTH RESULTS	15
3.6	GROUNDWATER CONDITIONS.....	15
3.7	SOIL CHEMISTRY.....	16
4.0	DISCUSSION AND RECOMMENDATIONS	18
4.1	COLLUVIUM DEPOSITS	19
4.2	MSE WALL.....	19

GEOTECHNICAL INVESTIGATION REPORT

4.2.1	Subgrade Preparation Below MSE Walls	20
4.2.2	Excavations and Dewatering	21
4.2.3	Shear Key Construction	21
4.2.4	Selection of Cross-Sections	21
4.2.5	Development of Analytical Models.....	22
4.2.6	Analysis Assumptions	22
4.2.7	Soil Parameters.....	23
4.2.8	Groundwater Conditions.....	24
4.2.9	Results of Slope Stability Analyses.....	24
4.2.10	Slope Stability Conclusions	25
4.2.11	Alternative Designs.....	26
4.2.12	Continuous Flight Auger Piles (CFA).....	27
4.3	SETTLEMENT PARAMETERS FOR MSE WALL.....	27
4.4	EMBANKMENT FILL BEHIND MSE WALLS	28
4.4.1	Subgrade Preparation	28
4.4.2	Site Grading and Drainage.....	28
4.5	PAVEMENT STRUCTURE	29
4.5.1	Backfill and Compaction Requirements.....	30
4.6	EROSION CONTROL MEASURES.....	32
4.7	GEOTECHNICAL INSTRUMENTATION AND MONITORING DURING CONSTRUCTION	32
4.8	ARCH CULVERT FOUNDATIONS	33
4.8.1	Driven Steel Piles	33
4.8.2	Frost Consideration for Piles.....	35
4.8.3	Pile Settlement	35
4.8.4	Negative Skin Friction and Downdrag Loads on Piles.....	36
4.8.5	Installation and Monitoring of Driven Steel Piles.....	36
4.8.6	Lateral Resistance of Piles	37
4.9	LIFT STATION	38
4.9.1	Braced Excavations	38
4.9.2	Bearing Capacity at Base of Excavation.....	39
4.9.3	Unbraced Shallow Excavations.....	39
4.9.4	Trench Backfill	40
4.10	BORROW MATERIAL AND MATERIAL RE-USE	40
4.11	CEMENT TYPE FOR SUBSURFACE CONCRETE	40
4.12	SOIL CORROSIVITY FOR STEEL PILES.....	41
4.13	ASSUMPTIONS AND AVAILABLE INFORMATION LIMITATIONS.....	41
5.0	CLOSURE.....	42

GEOTECHNICAL INVESTIGATION REPORT

LIST OF TABLES

Table 3-1	Summary of Unconfined Compressive Strength Results.....	15
Table 3-2	Summarized Groundwater Level Measurements	16
Table 3-3	Summary of Chemical Analyses Results of Soil Samples.....	17
Table 4-1	Soil Parameters.....	23
Table 4-2	Summary of Slope Stability Analyses Results After Excavation of Shear Key	24
Table 4-3	Summary of Slope Stability Analyses Results	24
Table 4-4	CFA Pile Design Criteria	27
Table 4-5	Preliminary Settlement Parameters	27
Table 4-6	Compaction Requirements	31
Table 4-7	Recommended Unfactored Shaft and End Bearing Resistance for Driven Steel Piles.....	34
Table 4-8	Soil Model Inputted for LPILE Analysis	37
Table 4-9	Lateral Earth Pressure Parameters.....	39

LIST OF APPENDICES

Appendix AStatement of General Conditions
Appendix B Figures
Appendix CSymbols & Terms and Borehole Records
Appendix DLaboratory Test Results
Appendix ESlope Stability Outputs
Appendix FLPILE Outputs

GEOTECHNICAL INVESTIGATION REPORT

Introduction
February 24, 2017

1.0 INTRODUCTION

The Stantec geotechnical team completed a geotechnical investigation to support the Aurum Road crossing of Clover Bar Creek in Edmonton, Alberta. Aurum Road Stage 7 extends between 9 Street and 17 Street Northeast (NE) and the crossing of Clover Bar Creek is to be located about 100 m west of 17 Street NE. This report summarizes the results of our findings and outlines recommendations for design and construction of the proposed crossing and other project components.

In general, the project consists of a crossing of Clover Bar Creek, and extension of the existing Aurum Road to the east of 9 Street and west of 17 Street NE to tie into the Province's ring road. For the purpose of geotechnical reporting, the project has been organized into four main areas as follows:

- Crossing of Clover Bar Creek including Mechanically Stabilized earth wall (MSE) and an arched culvert;
- Aurum Road Alignment between 9 Street and 17 Street NE;
- Construction of new Storm Water Management Facility (SWMF);
- Construction of new Lift Station;

This geotechnical investigation was conducted in general accordance with our proposal dated June 28, 2016 and the subsequent revisions and/or change orders. The purpose of this investigation was to review the available geotechnical information in the vicinity of the proposed Clover Bar Creek crossing, assess the subsurface conditions at multiple borehole locations, and based on the conditions encountered; provide geotechnical recommendations for design and construction of the proposed crossing and the related project components (lift station, SWMF, Aurum road pavement structure, etc.).

Preliminary geotechnical evaluations and recommendations for various components of the project have previously been provided to the design team in support of the preliminary design phase of the project. This report provides the results and recommendations of our geotechnical investigation and analysis that were carried out to provide the design parameters so that the detailed design can proceed. It is understood that additional ongoing geotechnical support and analysis is required to support the detailed design of the precast concrete arch, MSE walls, roadway embankment, and SWMF for this project. To carry out the additional analysis some information and input is required to be provided by the concrete arch and MSE Wall designers and suppliers. A close liaison with the designers, Sureway construction team and its sub-contractors will continue to be carried out to provide the detailed design parameters that are required. These additional efforts will be included in the next submission to the City of Edmonton.



GEOTECHNICAL INVESTIGATION REPORT

Introduction
February 24, 2017

Limitations associated with this report and its contents are outlined in the Statement of General Conditions provided in **Appendix A**.

1.1 SCOPE OF WORK

The scope of work for this geotechnical investigation included the following:

- Coordinating and supervising underground utility locates;
- Coordinating access road construction;
- Conducting a field drilling program to characterize the subsurface conditions at selected borehole locations;
- Monitoring the groundwater levels in selected boreholes; and
- Preparing a report summarizing the results of the investigation and presenting geotechnical recommendations related to the design and construction of various components of the proposed project.

1.2 SITE AND PROJECT DESCRIPTION

The site lies within W 22-53-23-W4M and SE 21-53-23-W4M of the Aurum Energy Park in northeast Edmonton, Alberta at the intersection of Aurum Road with 9 Street NE and extends to the 17 Street NE as shown on Figure 1 in **Appendix B**. The site is located within grass covered uncultivated lands surrounding the Clover Bar ravine system. Clover Bar Creek passes through the site in a northwest-southeast orientation and forms a ravine system with well vegetated slopes with a ravine depth of about 17 m at the crossing. Ravine slope angles generally range from 2.5H:1V to 3H:1V.

A review of available contour map of the site indicates the local topographical relief to slopes from the southeast to the northwest, towards the North Saskatchewan River valley. Localized surface drainage is towards Clover Bar Creek, which flows towards the North Saskatchewan River, located about 1 km to the north.

Due to the area being environmentally sensitive and falling within the River Valley bylaw, consideration should be given to wildlife passage. Also, in order to accommodate an open bottom culvert, the creek would require channel re-alignment.

The proposed re-aligned channel has 4 m wide streambed with 1H:1V sideslopes with 1.0 m average depth of channel. The proposed channel will have a sinusoidal pattern and will be armoured with class 1 rock riprap along the sides and bottom for scour and erosion protection.

GEOTECHNICAL INVESTIGATION REPORT

Introduction
February 24, 2017

The Clover Bar Creek is a meandering creek incised within a relatively wide ravine. The Clover Bar Creek flows from southwest to northeast at the crossing location. Existing thalweg vertical profile suggests that it is dropping from approximately elevation 631.5 m at the upstream side (station 0+140) to 629.5 m at the down-stream side (station 0+280). The existing slopes are currently 17 degrees for the south side of the valley and 15 degrees at the north side. The creek on the ravine floor appears to flow against the toe of the north side ravine slope at the crossing location.

The proposed Aurum Road alignment is approximately 850 m long and will cross Clover Bar Creek as shown on Figure 2 in **Appendix B**. The proposed alignment will connect the two ends of Aurum Road between 9 Street NE and 17 Street NE. Construction of Aurum Road includes realigning Clover Bar Creek and the construction of a 21.5 m span by 8.0 m high by 67.0 m long arch culvert. The total embankment height is to be about 17 m, with about 8 m of fill over top of the arch. The proposed road elevation at the crossing location will be approximately at 649 m.

It is unknown as what type of arch culvert will be utilized (corrugated steel plate, or pre-cast concrete arch). Mechanically Stabilized Earth (MSE) walls are proposed to limit the length of the arch culvert and the footprint of the embankment. The proposed MSE walls are almost 18 m in height at the north side of the arch culvert, and taper out over the ravine valley slopes over distances varying from 40 to 50 m. The proposed grade behind the walls ranges from 3H:1V to 4H:1V. The proposed slope in front of the MSE walls ranges from 2.5H:1V to 3H:1V.

Additionally, a lift station is planned on the north side of the creek crossing. The lift station will have an inside diameter of 9 m and a depth of approximately 12 m to 12.5 m.

Construction of a 3 m deep storm water pond is also being considered approximately 300 m northeast of the intersection of Aurum Road and 9 Street NE. Recommendations for the pond area will be provided under a separate cover as the pond details have not been finalized at the time of writing this report.

GEOTECHNICAL INVESTIGATION REPORT

Methodology
February 24, 2017

2.0 METHODOLOGY

2.1 DESKTOP REVIEW

A geotechnical desktop review was completed prior to commencement of the field drilling program. The desktop review consisted of reviewing geotechnical information available from previous nearby projects, geological mapping, aerial photographs, and coal mining activity.

2.1.1 Site Reconnaissance

Prior to the start of the field drilling program, Stantec conducted a site visit for the purpose of reviewing the proposed crossing location, planning the field drilling program including access conditions for the drill rig, and selection of borehole locations.

On July 24, 2016, Mr. Ian Darrach and Mr. Mohamed Abdelrahman of Stantec conducted a site reconnaissance to review the proposed crossing location from a slope stability perspective. A review of the stability of the ravine slopes, floodplain conditions, and creek conditions from an erosion perspective was also assessed.

Based on the visual observations at the time of the site visit, it appeared that the valley slopes are relatively stable at the present time. A knob on the valley slope located immediately to the southeast of the crossing location has been observed and it appeared to be a relic slump block. Evidence of beaver dams and beaver activity was also observed. Bedrock (sandstone) exposures have been observed at multiple locations to the north and south sides of the creek.

Evidences of debris and garbage was noted at different locations across the valley slopes and on the terrace above the creek.

2.1.2 Geological Review

A review of geology maps¹ suggested relatively recent alluvial deposits of silts, clays, and gravels as the dominant near-surface native soil conditions at the site. The alluvial deposits are underlain by bedrock of the Edmonton Formation consisting of bentonitic shales and sandstones with numerous coal seams.

The present North Saskatchewan River and its tributaries in the Edmonton region were downcut following the drainage of Glacial Lake Edmonton, starting about 12,000 years ago. However, there is little evidence of further downcutting over the last 8,000 years and the river is mainly meandering sideways and widening its valley.



Kathol, C.P. and McPherson, R.A., 1975. *Urban Geology of Edmonton*, Alberta Research Council, Bulletin 32.

GEOTECHNICAL INVESTIGATION REPORT

Methodology
February 24, 2017

As erosion continues, the river and tributary valleys continue to be affected by undercutting and slumping, particularly at the outside meander bends of the river and creeks. Conversely, the inside meander bends produce deposition, building flood plains and point bar deposits. The Edmonton Waste Management Centre, is located on a low level terrace of the North Saskatchewan River, and Clover Bar Creek leaves its ravine at this terrace at a location about 400 m to the northwest of the crossing site.

The bedrock belonging to the upper Cretaceous aged Horseshoe Canyon Formation of the Edmonton Group underlies the surficial glaciolacustrine and glacial till deposits. The Horseshoe Canyon Formation is generally comprised of interbedded mudstones (bentonitic shales), sandstone and coal seams with occasional thin bentonite seams.

Review of aerial photographs of the ravine did not indicate the presence of any active slumping of the slopes. However, contours and LiDAR imaging suggest that the knob on the valley slope located immediately to the southeast of the crossing location may be a relic slump block. The top of this knob is about 4 m below the adjacent upland topography. It is considered that the ravine slopes were formed by landslides during the downcutting phase of the river valley system and that these slopes are presently inactive-mature movements.

2.1.3 Available Geotechnical Reports

Stantec reviewed the following geotechnical report:

- Geotechnical Investigation Cloverbar/Aurum Industrial Park, Edmonton, AB. Project No. 123310692.200. Stantec Consulting Ltd. Dated November 17, 2011.

Stantec's 2011 investigation was for the overall Aurum Industrial Park in which the current site is located. Four (4) boreholes were located within our site area near the road alignment, proposed pond, and valley crest and have been included in **Appendix C**.

2.1.4 Aerial Photograph Review

Stantec reviewed aerial photographs spanning from 1949 to 2016. Historic site use appears to be agricultural from 1949 to around 1992. Cultivation appeared to have ceased after 1992. No signs of slope instability and/or deep seated failures were observed within the ravine areas.

2.1.5 Coal Mining Activity

Information from Alberta Energy Regulator's online coal mine map viewer indicated no previous coal mines in the area.

GEOTECHNICAL INVESTIGATION REPORT

Methodology
February 24, 2017

2.2 FIELD DRILLING PROGRAM

Prior to the start of the investigation, Stantec coordinated the location of underground utilities using Alberta One-Call and a private utility locator. Additionally, temporary access roads to the borehole locations were provided by Sureway Construction Group Ltd.

Upon obtaining utility clearances, seventeen (17) boreholes (BH01 to BH17) and seven (7) hand auger holes (BH18 to BH24) were advanced from September 7 to September 20, 2016. The boreholes were advanced to depths ranging from 4.3 m to 25.5 m using a track-mounted drill rig owned and operated by All Service Drilling Inc. The hand auger holes were advanced to depths ranging from 1.2 m to 2.0 m. The locations of the boreholes are shown on Figure 2 in **Appendix B**.

Disturbed grab samples were collected from the augers at regular intervals. Standard Penetration Tests (SPTs) were carried out at regular intervals by utilizing a 50 mm diameter split-spoon sampler. Relatively undisturbed Shelby tube samples of cohesive soil were also obtained for potential laboratory testing. Wet rotary coring of the bedrock was completed on select boreholes (BH02 to BH06, BH08 to BH13, and BH15). Further details of the sampling and testing carried out are provided on the borehole records presented in **Appendix C**.

At the completion of drilling, 25 mm PVC standpipe piezometers and vibrating wire piezometers were installed within select boreholes. A total of ten (10) standpipes and four (4) vibrating wire piezometers were installed. Backfill details at each borehole location are provided on the borehole records in **Appendix C**. The standpipes were not decommissioned as part of this investigation.

Survey of the borehole locations was completed by Stantec Geomatics.

2.3 LABORATORY TESTING

All soil samples recovered from the boreholes were placed in water-proof sampling bags, appropriately labeled, and returned to our laboratory for geotechnical classification and testing. Laboratory tests included determination of natural water content, Atterberg limits, grain size distributions, unit weights, unconfined compressive strength testing, and direct shear tests. Resistivity, pH, chloride, and soluble sulphate content tests were also tested by Maxxam Analytics. Detailed results of the laboratory testing can be found in the attached borehole records in **Appendix C** and **Appendix D**.

GEOTECHNICAL INVESTIGATION REPORT

Subsurface Conditions
February 24, 2017

3.0 SUBSURFACE CONDITIONS

The soil and groundwater conditions encountered in the boreholes are described in detail on the borehole records and summarized in the following sections. The soils have been classified according to the Modified Unified Soil Classification System (MUSCS). A detailed description of the soils encountered in each borehole can be found in the Borehole Records included in **Appendix C**.

The estimated stratigraphic boundaries in these borehole records are based on visual examination of soil samples at the time of drilling and laboratory testing results. Therefore, transitions between soil types at these specific locations do not necessarily indicate the exact change in geological planes in the area. Subsurface conditions may vary both with depth and laterally between individual borehole locations.

For the purposes of this report, the subsurface soil conditions are separated and discussed for each component of the project in the following sections.

3.1 ROAD ALIGNMENT

Two (2) boreholes (BH14 and BH15) were drilled within the proposed Aurum Road alignment. In general, the soils encountered in the boreholes consisted of topsoil, overlying clay till, overlying bedrock.

3.1.1 Topsoil

Topsoil was encountered at surface in both BH14 and BH15 with a thickness ranging from 300 mm to 800 mm. The topsoil shown on the borehole records are expected to vary between borehole locations and may be greater than shown.

3.1.2 Clay Till (CI-CH)

Clay till was encountered below the topsoil in both boreholes. BH14 was terminated within this layer while the thickness was 4.3 m in BH15 which corresponds to an approximate bottom elevation of 644 m. The clay till was light brown to brown in color and consisted of a silty, sandy, clayey matrix with trace gravel. The clay was observed to be occasionally oxide stained and contained occasional coal fragments.

Moisture contents of the clay till ranged from 14% to 30%. Two Atterberg Limit tests were completed on samples of the clay till and resulted in a Liquid Limit of 38% to 64% and a Plastic Limit of 18% to 28% indicative of medium to high plastic clay.

Uncorrected Standard Penetration Test (SPT) N-values typically ranged between 9 and 12. Based on the N-values, the consistency of the clay till is estimated to be stiff.



GEOTECHNICAL INVESTIGATION REPORT

Subsurface Conditions
February 24, 2017

3.1.3 Bedrock

The clay fill was underlain by grey and dark brown stratified clay shale and sandstone of the Edmonton Formation in BH15 and extended to the termination depth. The clay shale and sandstone was generally highly to completely weathered and extremely weak with localized zones that were medium strong. Numerous coal seams were encountered throughout the bedrock.

The natural water content of the bedrock layer generally ranged from 12% to 30% with occasional outliers as high as 61%. Moisture contents of 39% and 61% were observed in the upper shales and may be due to water flow through the underlying coal seams. One Atterberg limit test identified the clay shale as high plastic with a Plastic Limit and Liquid Limit of 27% and 55%, respectively.

Soil strengths were estimated using SPT N-values and one unconfined compressive strength (UCS) test. Uncorrected N-values of the bedrock ranged from 24 to 41. Based on the N-values the undrained shear strength was estimated to be 120 kPa to 205 kPa. The UCS test yielded an undrained shear strength of 165 kPa.

One direct shear test was completed on a sample of clay shale. The test resulted in a cohesion value of 0 kPa and peak friction angle of 26° for the clay shale with residual friction angle of 13°.

3.2 POND AND BORROW AREA

Three (3) boreholes (BH01, BH16, and BH17) were drilled within the proposed pond area. In general, the soils encountered in the boreholes consisted of topsoil, overlying clay till, overlying sand. In borehole BH 01, thin seam of clay fill was encountered within sand layer while in borehole BH 17, the sand layer was underlain by till layer.

3.2.1 Topsoil

Topsoil was encountered at surface in BH01, BH16, and BH17 with a thickness ranging from 200 mm to 300 mm. The topsoil shown on the borehole records are expected to vary between borehole locations and may be greater than shown.

GEOTECHNICAL INVESTIGATION REPORT

Subsurface Conditions
February 24, 2017

3.2.2 Clay Till (CI)

Clay till was encountered below the topsoil in all three boreholes. The clay till was light brown to brown in color and consisted of a silty, sandy, clayey matrix with trace gravel. The clay was observed to be occasionally oxide stained with occasional rootlets in the upper meter. A sand layer was encountered between the clay till in BH17 with two sand layers encountered in BH01. The upper clay till had a thickness ranging from 2.8 m to 3.7 m which corresponds to an approximate bottom elevation ranging from 642 m to 643 m. At about elevation 638 m, a clay till layer with a thickness of 0.7 m was encountered in BH01 between the two sand layers. Boreholes BH01 and BH17 were terminated within the lower clay till layer.

Moisture contents of the clay till ranged from 9% to 25%. Three Atterberg Limit tests were completed on samples of the clay till and resulted in a Liquid Limit of 38% to 46% and a Plastic Limit of 16% to 21% indicative of medium plastic clay.

Uncorrected SPT N-values typically ranged between 16 and 23. Two outliers were encountered with an N-value of 39 and 75 and may be due to the presence of gravel. Based on the N-values, the consistency of the clay till is estimated to be very stiff.

3.2.3 Sand

Brown poorly graded sand (SP) was encountered underlying the clay till layer in all three boreholes. The sand was noted to contain various amounts of clay and silt with trace to some gravel. The sand was occasionally oxide stained and had a thickness ranging from 1.7 m to 4.2 m which corresponds to a bottom elevation ranging from 636 m to 639 m. Borehole BH16 was terminated within this sand layer.

Moisture contents of the poorly graded sand ranged from 3% to 15%.

SPT's carried out in the poorly graded sand resulted in uncorrected N-values ranging from 22 to 51. Based on SPT N-values, the silty sand is characterized as compact to very dense.

3.3 LIFT STATION

Two (2) boreholes (BH06 and BH07) were drilled near the proposed lift station area. In general, the soils encountered in the boreholes consisted of topsoil, overlying clay till, overlying sand, underlain by bedrock.

3.3.1 Topsoil

Topsoil was encountered at surface in both BH06 and BH07 with a thickness of 300 mm. The topsoil shown on the borehole records are expected to vary between borehole locations and may be greater than shown.



GEOTECHNICAL INVESTIGATION REPORT

Subsurface Conditions
February 24, 2017

3.3.2 Clay Till (CI)

Clay till was encountered below the topsoil in all three boreholes. The clay till was light brown to brown in color and consisted of a silty, sandy, clayey matrix with trace gravel. The clay was observed to be occasionally oxide stained and contained occasional coal fragments. Both boreholes contained a sand layer underlain by rafted bedrock. The upper clay till layer was 4.3 m thick in both boreholes which corresponded to a bottom elevation of 644 m. The lower clay till layer ranged from 1.2 m to 1.5 m thick which corresponded to approximate bottom elevations ranging from 638 m to 640 m. A 400 mm thick dense sand seam was encountered in the lower clay till layer in BH07.

Moisture contents of the clay till ranged from 9% to 27%. One Atterberg Limit test was completed on the clay till and resulted in a Liquid Limit of 38% and a Plastic Limit of 18% indicative of medium plastic clay.

Uncorrected Standard Penetration Test (SPT) N-values typically ranged between 15 and 22. One unconfined compressive strength test was conducted on a sample of the clay till and yielded an undrained shear strength of 149 kPa. Based on the N-values and undrained shear strength, the consistency of the clay till is estimated to be very stiff.

3.3.3 Sand

Sand was encountered below the upper and lower clay till in both BH06 and BH07. The upper sand layer was light brown and poorly graded with trace gravel. The lower sand layer was brown, poorly graded, and was noted to be silty and/or clayey with trace gravel. The upper sand layer ranged from 1.5 m to 2.3 m in thickness which corresponds to a bottom elevation from 642 m to 643 m while the lower sand layer was 1.2 m to 1.8 m thick and corresponds to a bottom elevation from 637 m to 638 m.

Moisture contents of the upper sand ranged from 1% to 4%. Moisture contents of the lower sand ranged from 10% to 16%.

Uncorrected SPT N-values typically ranged between 19 and 32 in the upper sand and 12 to 48 in the lower sand. Based on the N-values, the compactness of the upper and lower sand is estimated to be compact to dense.

GEOTECHNICAL INVESTIGATION REPORT

Subsurface Conditions
February 24, 2017

3.3.4 Bedrock

The upper sand layer was underlain by a rafted layer of stratified brown clay shale and sandstone. The rafted bedrock was highly weathered, extremely weak, and contained occasional oxide staining. The rafted bedrock had a thickness of 2.3 m to 2.6 m corresponding to a bottom elevation ranging from 639 m to 641 m.

The lower sand layer was underlain by stratified clay shale and sandstone of the Edmonton Formation in both boreholes. The lower bedrock was generally highly to completely weathered and extremely weak with localized zones that were medium strong. Additionally, two seams of bluish-grey bentonitic sandstone layers were observed at various depths up to 500 mm thick in BH06. Numerous coal seams were encountered throughout the bedrock. Both boreholes were terminated within this lower bedrock layer.

The natural water content of the bedrock layer generally ranged from 13% to 31% with outliers as high as 53%. The high outlier moisture contents may be due to nearby water bearing coal seams. Two Atterberg Limit tests were completed on samples of the bedrock and resulted in a Liquid Limit of 43% to 51% and a Plastic Limit of 19% to 21% indicative of medium to high plastic clay.

Shear strengths for the rafted bedrock were obtained using SPT N-values. In general, the N-values increased with depth suggesting a softened behavior in the upper 2 m of the bedrock. A plot of the N-Values vs. bedrock depth is provided in Figure 8 in **Appendix B**. The uncorrected N-values in the rafted bedrock ranged from 40 to 74 corresponding to estimated undrained shear strengths of 200 kPa to 370 kPa. Soil strengths in the lower bedrock were obtained using SPT N-values and UCS tests. Uncorrected N-values of the lower bedrock ranged from 40 to 78 corresponding to estimated undrained shear strengths from 200 kPa to 390 kPa. Two UCS tests yielded undrained shear strengths of 218 kPa and 284 kPa.

One direct shear test was completed on a sample of interbedded sandstone and clay shale. The test resulted in a cohesion value of 60 kPa and peak friction angle of 40° for the interbedded clay shale and sandstone with residual friction angles of 24°.

3.4 CULVERT AND CREEK AREA

Twenty (20) boreholes (BH02 to BH05, BH08 to BH13, and BH18 to BH24) were drilled within the proposed culvert and creek area. In general, the soils encountered in the boreholes consisted of topsoil, overlying colluvium or clay till or sand, overlying bedrock.

In the uplands adjacent to the creek, under a thin layer of topsoil, surficial deposits of clay till were encountered. In many boreholes, in particular on the east side of the ravine, a sand and gravel layer (Empress or Pleistocene) was encountered underlying the clay till. Clay shale and/or sandstone bedrock was encountered at a depth of about 6 m on the west side of the ravine and about 12 m on the east side of the ravine.



GEOTECHNICAL INVESTIGATION REPORT

Subsurface Conditions
February 24, 2017

In the six boreholes advanced at or near the bottom of the ravine, the depth to bedrock varied from less than 1 m to almost 6 m below grade. Overlying the bedrock, colluvial slope debris often comprised of clay till material with some wood fragments. Of note, in three of these boreholes, this colluvial material was noted to depths of up to 2 m below the present creek channel bottom.

The bedrock encountered below the valley bottom was significantly softened, with the upper 3 or 4 m of it being softened to soil like conditions, below which the typical extremely weak rock of cretaceous origin was encountered. In boreholes advanced in the uplands, only about 1 to 2 m of the upper bedrock surface was noted to be softened. Slickensided core samples were encountered at approximate elevations of 629 m, 627 m, and 618 m in BH12, BH03, and BH09, respectively.

3.4.1 Topsoil

Topsoil and/or organics was encountered at surface in BH01, BH02, BH06 to BH08, BH10, BH11, and BH13 to BH24 with a thickness ranging from 200 mm to 800 mm. Topsoil was also observed along the temporary access roads and generally had a thickness ranging from 300 mm to 450 mm. The topsoil and organic thickness shown on the borehole records are expected to vary between borehole locations and may be greater than shown.

3.4.2 Clay Till (CH)

Clay till was encountered at surface in BH03, BH05, BH09, and BH12 and below the topsoil in BH08. Clay till was also encountered underlying the sand layer and the sand and gravel layer in BH11 and underlying sand in BH05. The clay till had a thickness ranging from 0.5 m to 5.5 m. This corresponds to a bottom elevation ranging from 632 m to 644 m. The clay was brown and consisted of a silty, sandy, clayey matrix with trace gravel. The clay was observed to be occasionally oxide stained and contained occasional coal fragments.

Moisture contents of the clay till ranged from 12% to 21%. Two Atterberg Limit tests were completed on samples of the clay till and resulted in a Liquid Limit of 53% to 71% and a Plastic Limit of 27% to 35% indicative of high plastic clay.

Uncorrected Standard Penetration Test (SPT) N-values typically ranged between 20 and 25. Several outliers were encountered with N-values of 0, 9 and 41. The N-Value of 0 was considered to be unrepresentative of the clay till due to its proximity to the groundwater table. Based on the N-values, the consistency of the clay till is estimated to be very stiff.

GEOTECHNICAL INVESTIGATION REPORT

Subsurface Conditions
February 24, 2017

3.4.3 Sand

Sand was encountered between the clay fill in BH05 with a thickness of 2 m which corresponds to a bottom elevation of 640 m. The sand was brown and consisted of a silty, sandy, clayey matrix. The sand fill was observed to contain occasional coal fragments.

Moisture contents of the sand fill ranged from 7% to 12%.

One uncorrected SPT N-Value of 35 was recorded within the sand. Based on the N-value, the compactness of the sand is estimated to be dense.

3.4.4 Clay Colluvium

Clay colluvium was encountered at surface in BH02, below the topsoil in BH10, BH13, BH18 to BH21, BH23, and BH24, and below sand and gravel in BH22. The colluvium had a thickness ranging from 0.5 m to 5.1 m corresponding to bottom elevations ranging from 628 m to 635 m. The colluvium was brown to dark brown in color and consisted of a silty, sandy, clayey matrix with trace gravel. The clay was observed to be occasionally oxide stained and contained occasional coal fragments, bedrock fragments, and wood pieces. Voids may also be present within the colluvium.

Moisture contents of the clay fill ranged from 19% to 42%. One Atterberg Limit test was completed the clay colluvium and yielded a Liquid Limit of 49% and a Plastic Limit of 26%, indicative of medium plastic clay.

Uncorrected Standard Penetration Test (SPT) N-values typically ranged between 4 and 8. Based on the N-values, the consistency of the colluvium is estimated to be soft to firm.

3.4.5 Sand (SP)

Brown poorly graded sand (SP) was encountered at surface in BH04 and below the topsoil in BH11. The sand was noted to contain various amounts of silt with trace gravel. The sand had a thickness ranging from 0.5 m to 4.6 m which corresponds to bottom elevations ranging from 636 m to 643 m.

Moisture contents of the poorly graded sand ranged from 2% to 15%.

SPT's carried out in the poorly graded sand resulted in uncorrected N-values ranging from 14 to 17. Based on SPT N-values, the sand is characterized as compact.

GEOTECHNICAL INVESTIGATION REPORT

Subsurface Conditions
February 24, 2017

3.4.6 Sand and Gravel

Light brown to brown poorly graded sand and gravel was encountered below the clay fill in BH05, BH11, and BH22. The gravel pieces were noted to be rounded. The sand and gravel layer had a thickness ranging from 0.4 m to 2.2 m which corresponds to bottom elevations ranging from 630 m to 637 m.

Moisture contents of the poorly graded sand ranged from 2% to 15%.

SPT's carried out in the poorly graded sand resulted in uncorrected N-values ranging from 14 to 17. Based on SPT N-values, the sand is characterized as compact.

3.4.7 Bedrock

Clay shale and sandstone bedrock was encountered underlying colluvium in BH02, BH10, BH13, BH19, BH20, BH23, and BH23 and underlying clay till in BH03, BH08, BH09, BH11, and BH12. Bedrock was also encountered underlying sand in BH04 and underlying the sand and gravel layer in BH05. Up to 6 m of overburden was encountered overlying the bedrock within the creek (BH02, BH03, BH09, BH10, BH12, and BH13) with an average of about 3 m. The clay shale and sandstone was generally highly to completely weathered and extremely weak to weak with localized zones that were medium strong. Numerous coal seams were encountered throughout the bedrock. Thinly laminated zones of sandstone and clay shale were also observed at various depths. Slickensides were observed at elevations 627 m, 618 m, and 629 m in BH03, BH09, and BH12, respectively.

The natural water content of the bedrock layer generally ranged from 14% to 32% with occasional outliers as low as 10% and as high as 51%. The higher moisture contents may be due to nearby water bearing coal seams and localized bentonite seams. Atterberg Limit tests were completed on samples of the bedrock and resulted in Liquid Limits ranging from 33% to 74% and Plastic Limits ranging from 13% to 30% indicative of medium to high plastic clay.

Soil strengths were estimated using SPT N-values and unconfined compressive strength (UCS) tests. In general, the N-values increased with depth suggesting a softened behavior in the upper 4 m of the bedrock. A plot of the N-Values vs. bedrock depth is provided in Figure 8 in **Appendix B**. The upper bedrock (above elevation 628 m) along the creek (BH02, BH03, BH10, BH12, and BH13) showed signs of disturbance based on moisture content and SPT N-values. Uncorrected N-values of the bedrock ranged from 9 to 88. SPT refusal in the bedrock was also encountered at various depths. The N-values of the bedrock corresponds to estimated undrained shear strengths from 45 kPa to 440 kPa. UCS tests yielded undrained shear strengths of 133 kPa and 510 kPa.

GEOTECHNICAL INVESTIGATION REPORT

Subsurface Conditions
February 24, 2017

3.5 SUMMARIZED UNCONFINED COMPRESSIVE STRENGTH RESULTS

A summary of the UCS test results is provided below in **Table 3-1**. The complete UCS results can be found in **Appendix D**.

Table 3-1 Summary of Unconfined Compressive Strength Results

Borehole	Sample	Depth (m)	Elevation (m)	Soil Unit	Liquid Limit (%)	Unconfined Compressive Strength, q_u (kPa)
BH02	RC4	12.0	621.1	Clay Shale	57	1021
BH06	ST5	3.5	645.2	Clay Till	-	298
BH06	RC5	18.9	629.8	Clay Shale	-	567
BH06	RC9	24.7	624.0	Clay Shale	51	435
BH09	RC2	5.8	628.8	Clay Shale	46	434
BH09	RC9	17.1	617.5	Clay Shale	74	267
BH10	RC6	12.3	620.4	Clay Shale	55	851
BH12	RC4	9.3	625.6	Clay Shale	-	310
BH13	RC1	6.4	626.1	Clay Shale	38	389
BH15	RC2	9.6	638.8	Clay Shale	-	330

3.6 GROUNDWATER CONDITIONS

Standpipe piezometers were installed in BH01, BH02, BH04 to BH07, BH10, BH12, and BH15 to BH17 while vibrating wire piezometers were installed in BH08, BH11, BH13 and BH15. Installation details are provided on the Borehole Records in **Appendix C**. The measured groundwater levels are summarized in **Table 3-2** below and on the Borehole Records in **Appendix C**. The groundwater levels are expected to fluctuate seasonally, with higher levels being observed in the spring and summer. Fluctuations in groundwater levels will also occur depending on site use, adjacent site use, and following high precipitation events.

Measured water levels were recorded at about the creek level in boreholes at the creek bottom. Levels at about creek level were also encountered in some boreholes on the slopes where permeable layers such as coal seams appear to be interconnected to the valley floor. However, higher groundwater levels were found in many installations sealed in clay shale deposits towards the crests of the slopes, with levels ranging from 5 m to 15 m above the creek level.

GEOTECHNICAL INVESTIGATION REPORT

Subsurface Conditions
February 24, 2017

Table 3-2 Summarized Groundwater Level Measurements

Borehole	Screen Interval or Tip Depth (mbgs)	Elevation (m)	Groundwater Level Reading (mbgs)		
			Upon Drilling Completion (Elevation, m)	October 4, 2016 (Elevation, m)	November 23, 2016 (Elevation, m)
BH02	13.1 – 14.6	619.5 – 618.5	2.3 (630.8)	3.5 (629.6)	3.4 (629.8)
BH04	13.4 – 14.9	626.8 – 625.3	5.9 (634.3)	8.5 (631.7)	8.4 (631.8)
BH05	6.3 – 7.8	638.6 – 637.1	8.5 (636.4)	7.7 (637.2)	6.6 (638.3)
BH06	10.7 – 12.0	638.0 – 636.7	13.7 (635.0)	Dry	Dry
BH07	13.7 – 15.0	635.2 – 633.9	13.7 (635.2)	11.7 (637.2)	12.4 (636.5)
BH08*	13.6	628.3	8.3 (633.6)	12.0 (629.9)	Damaged
BH10	12.2 – 13.7	620.5 – 619.0	0 (632.7)	2.8 (629.9)	3.0 (629.7)
BH11*	14.2	629.5	7.5 (636.2)	13.0 (630.7)	13.7 (630.0)
BH12	10.2 – 11.5	624.7 – 623.4	5.0 (629.9)	4.3 (630.6)	4.3 (630.6)
BH13*	20.1	612.3	2.7 (629.7)	3.3 (629.1)	3.0 (629.4)
BH15*	24.6	623.8	5.7 (642.7)	Likely Damaged	Likely Damaged
BH15	5.8 – 7.3	642.6 – 641.1	5.7 (642.7)	4.0 (644.4)	4.0 (644.5)
BH16	6.1 – 7.6	639.6 – 638.1	8.9 (637.2)	7.72 (638.0)	7.7 (638.1)
BH17	4.6 – 6.1	641.5 – 640.0	8.5 (637.6)	Dry	Dry

3.7 SOIL CHEMISTRY

Chemical analysis was completed on six (6) selected soil samples from the boreholes to determine design considerations for concrete and steel in contact with the soils. Water soluble sulphate, chloride and resistivity testing was conducted by Maxxam Analytics International of Edmonton, Alberta. The test results are summarized in **Table 3-3**.

GEOTECHNICAL INVESTIGATION REPORT

Subsurface Conditions
February 24, 2017

Table 3-3 Summary of Chemical Analyses Results of Soil Samples

Borehole/Sample	Depth (m) (Elevation, m)	Soluble Chloride (mg/L)	Resistivity (ohm-m)	Conductivity (dS/m)	pH	Water Soluble Sulphate (%)
BH03 / BS8	5.0 (630)	8.9	8.5	1.2	7.17	<0.050
BH06 / ST5	3.1 – 3.7 (645.0 – 645.6)	20	23	0.43	7.62	<0.050
BH07, BS15	10.1 (638.8)	50	24	0.42	7.93	<0.050
BH09, BS3	2.0 (632.6)	97	14	0.74	7.72	<0.050
BH10, SS14	5.3 – 5.8 (626.9 – 627.4)	40	8.1	1.2	8.23	<0.050
BH12, RC4	9.3 (625.6)	57	4.0	2.5	8.60	<0.050

GEOTECHNICAL INVESTIGATION REPORT

Discussion and Recommendations
February 24, 2017

4.0 DISCUSSION AND RECOMMENDATIONS

Based on our understanding of the proposed crossing, and the subsurface conditions encountered in the 2011 and 2016 boreholes, the following geotechnical considerations are considered important for design and construction:

- The results of the site reconnaissance showed no visual signs of recent slope instability in the area of the proposed crossing. A knob on the valley slope located immediately to the southeast of the crossing location has been observed and it appeared to be a relic slump block. The slopes and floodplain area are well vegetated. There were signs of erosion at the ravine toe. Signs of beaver activity within the ravine were also noted that may cause future flooding, which should be anticipated in the design of the crossing.
- Due to the large height of the proposed MSE walls, it will not be possible to construct the walls on the existing soils in the valley bottom without implementing mitigation measures. These mitigation measures will entail excavation below the proposed reinforced soil mass (MSE fill) in order to remove potential weak materials from under and the front of the MSE wall.
- A slope stability analysis was undertaken for the proposed mechanically stabilized earth (MSE). To satisfy the factor of safety criteria of 1.5 for the long term condition, and 1.3 for end of construction conditions, a mechanically stabilized earth (MSE) slope with a shear key is recommended for most of the MSE wall. Some sections of the MSE wall will have to be supported on piled foundations as described in more detail in later sections.
- In order to reduce the size of MSE wall and shear key dimensions different options have also been evaluated, such as replacing shear key with continuous flight auger (CFA) piles under selected MSE wall sections with replacing the soft material below the walls with pit run gravels. Light weight fill options such as bottom ash, cematrix and ESP foam behind the MSE walls have also been considered to mainly reduce the driving force and improve stability.
- A follow-up confirmatory geotechnical drilling program is recommended prior to construction to confirm the above assumptions and to address any data gaps. The follow-up drilling program should include several boreholes on the northeast side of the arch culvert to confirm the subsurface conditions are consistent with the above design assumptions.
- Design of the north side and south side MSE head slopes should be carried out by the design build contractor. Drainage behind the stabilized earth sections (behind the reinforced zone) will be important to the design. Monitoring of settlements, lateral displacement, and excess pore water pressures in the foundation soils/bedrock and embankment fills during construction is also recommended.

GEOTECHNICAL INVESTIGATION REPORT

Discussion and Recommendations
February 24, 2017

- Driven steel H-piles are preferred over driven steel pipe piles and drilled cast-in-place concrete caissons for the arch culvert foundations. H-Pile (360x132) is the recommended pile size.
- It should be noted that as the embankment settles over time, that the transition between the approach embankment and the embankment for the overpass may experience differential settlements. This may potentially result in a “bump” in the approach slabs.
- Erosion and scour protection on all exposed slopes below and above the design creek flood level will be an important design element to address. The stability analysis did not consider a design scour removal of materials at the toe of the slopes or within the creek channel.

The following sections provide recommendations for design and construction of the MSE walls, embankment fill, lift station, pavement structure and deep foundations for arch culvert (driven steel H piles). For the purpose of this report we have assumed that all earthworks construction will be conducted in the non-winter months of the year (non-freezing temperatures).

4.1 COLLUVIUM DEPOSITS

The finding of colluvial deposits to elevations below the present creek level suggest that the creek had eroded to a lower level than its present creek channel thalweg at some time in the geologic past. This colluvium combined with the finding of a presheared surface in the clay shale bedrock just below the creek level, indicates a history of slumping of the valley walls at the site. This history of slumping in a geological timeframe and associated shear surfaces in the clay shales and the softened nature of the clay shale bedrock in the valley bottom both need to be considered in the design of the proposed crossing.

The proposed layout of the MSE walls and culvert is situated on colluvial deposits on either side of the creek. These deposits were not delineated during the field investigation and pose a risk for design and construction. Where encountered, the colluvium should be removed and replaced with engineered fill below the footprint of the MSE walls.

4.2 MSE WALL

Stability analyses were undertaken to assess the global stability of the proposed MSE walls. Target factors of safety have been established following the 2014 Canadian Highway Bridge Design Code. Factor of safety criteria of 1.5 for the long term condition, and 1.3 for end of construction conditions were utilized. The analysis considered anticipated soil conditions at the site, the varying heights of the MSE walls and any proposed retained slopes above the tops of the walls and slopes in front of the walls.

GEOTECHNICAL INVESTIGATION REPORT

Discussion and Recommendations
February 24, 2017

The slope stability analysis computer software program Geostudio 2016, by GEO-SLOPE International Ltd, was used for the analysis, which is based on the Limit Equilibrium Method. The failure mode of the slope was determined using the "Morgenstern-Price" method. This method has the advantage of satisfying both the force and moment equilibrium equations in the calculations for the factor of safety (FOS). The slope stability analysis considered a review of the global stability of the MSE wall after construction (short-term) and in the long term. In addition, slope stability analysis was also carried out for the anticipated excavated slopes during construction of shear keys.

4.2.1 Subgrade Preparation Below MSE Walls

Due to the significant height of the proposed MSE walls, it will not be possible to construct the walls on the existing soils in the valley bottom without implementing mitigation measures. In general, these mitigation measures will include excavation below the proposed reinforced soil mass (MSE fill) in order to remove potential weak materials from under and the front of the MSE wall. Weak materials include colluvium, pre-sheared high-plastic clay shales or highly softened bedrock materials. Based on the borehole information available, it is very difficult to estimate the extent of the weak material below, behind, and in front of MSE walls, therefore conservative assumptions have been made at certain locations for the extent of these weak materials. Further delineation of the extent of these materials will be required at the time of construction and through advancing additional boreholes prior to construction.

The sub-excavated zone should be backfilled with compacted crushed granular fill in order to provide a shear key to stabilize the MSE wall. The depths and widths of the shear keys will vary with the subsurface conditions encountered, and the heights of the MSE walls. The MSE walls will then be constructed on top of the shear keys. At the sections where pile foundations are required for slope stabilization, removal of weak materials will also be required. It is recommended that crushed aggregate material such as Alberta Transportation Designation 2, Class 20 or Class 25 be used as backfill for the shear key. Alternatively, equivalent backfill material may be used as approved by the engineer. The granular fill should be compacted in 200 mm lifts (loose) to a minimum 100 percent of the materials Standard Proctor maximum dry density (ASTM D698). Clay fill is not recommended as engineered fill for the shear key.

Where shear keys are not required, care should be taken to minimize disturbance to the competent native subgrade soils.

GEOTECHNICAL INVESTIGATION REPORT

Discussion and Recommendations
February 24, 2017

4.2.2 Excavations and Dewatering

Excavations behind and below the MSE wall will be required to construct the MSE wall. These excavated slopes should have a maximum back slope of 2H:1V. All excavations should be in accordance with the Alberta Occupational Health and Safety Act. Temporary excavations up to 3 m deep in the clay till, sand, sand and gravel, and bedrock may be sloped at 1H:1V provided that there is no water seepage. Alternatively, a shoring system may be used. Excavations should be inspected regularly for signs of instability and flattened as required.

Temporary surcharge loads, such as construction equipment and materials, should not be allowed within 1.5 m of an unsupported excavated face or within a distance equal to the depth of excavation, whichever is greater. Stockpiling of materials is expected at the top of the slope and it is recommended that stockpiles be kept a minimum of 30 m away from the slope crest. All excavations should be checked regularly for signs of sloughing, especially after periods of rain. Shallow slides from the side and excavated slopes are a potential source of danger to workers and should be guarded against.

Based on observations made during the drilling program and the measured groundwater levels, it is anticipated that seepage may occur in excavations extending below the creek elevation (approximately 630 m). Therefore, dewatering of excavations will be required below this depth. Also, dewatering of excavations will be dependent upon weather conditions and the time of year of construction. If encountered during construction, it is expected that groundwater may be temporarily controlled by sump and pumping methods due to low permeability material surrounding the creek channel.

4.2.3 Shear Key Construction

Shear keys up to 6 m below the base of MSE wall will be required for global stability except for part of the northwest wall where pile supported structure is required. Construction of the shear key can be completed by excavating in small sections and immediately backfilled with approved crushed granular fill. Compaction of the granular fill will be achieved by hoe-pack. Personnel should not be allowed to enter the shear key excavation as a safety precaution until the excavation is at least backfilled to half the depth.

4.2.4 Selection of Cross-Sections

The slope stability analysis of the MSE walls required selecting several cross-sections across each wall. A total of fifteen (15) cross-sections were selected for analysis as follows:

- Section A1, A2, and A3 are perpendicular to the northwest wall.
- Section B1, B2, B3, and B4 are perpendicular to the southeast wall
- Section C1, C2 and C3 are perpendicular to the northeast wall.
- Section D1, D2, and D3 are perpendicular to the southwest wall.

GEOTECHNICAL INVESTIGATION REPORT

Discussion and Recommendations
February 24, 2017

An additional two (2) sections, X1 and X2, were developed along the north and south edge of pavement. These sections provide a general overview of the soil stratigraphy and N-values encountered within the creek area.

Contour drawings of the site showing existing and proposed grades are provided on Figures 3 and 4 in **Appendix B**, respectively. The location of each cross-section listed above is shown on Figures 4 and 5 in **Appendix B**. Cross-sections of the overall valley are provided on Figures 6 and 7 in **Appendix B**.

4.2.5 Development of Analytical Models

The thirteen (13) cross-sections described in **Section 4.2.3** above were analyzed using the following available information:

- The soil and groundwater conditions from available borehole information.
- Surveyed points along exposed valley slopes.
- The existing ground surface topography across the site.
- The proposed layout of the MSE wall and culvert as provided by Stantec's Hydrotechnical group.
- The final grades across the site as provided by Stantec's Community Development group.

The slope stability outputs for each section are provided in **Appendix E**.

4.2.6 Analysis Assumptions

The following assumptions have been made for stability analyses:

- Pore water pressure response (b -bar) of 0.4 has been assumed for the softened bedrock and b -bar of 0.2 has been assumed for the clay fill. It should be noted that b -bar of 0.7 have been measured in the past on similar projects.
- A 2H:1V cut from the base of the MSE wall towards the road will be required to construct the wall. Clay fill will be used to backfill the cut slope in order to reach design grades.
- The pre-sheared zones (slickensides) at elevations 627 m and 629 m apply to the northwest and southwest walls only. Failure along these pre-sheared zones are critical.
- The pre-sheared zone at elevation 618 m and 629 m apply to the southeast wall only. Failure along this pre-sheared zone is critical.
- A 10 kPa surcharge was assumed from the slope crest to the full width of the roadway.
- Effective stress analysis (drained/long-term) is governing the design of the MSE wall.
- Total stress analysis (undrained/short-term) is applicable immediately after excavation of the shear key and construction of the MSE walls.



GEOTECHNICAL INVESTIGATION REPORT

Discussion and Recommendations
February 24, 2017

- A minimum L/H ratio of 0.8 will be required for global stability where L is the reinforcement length behind the wall face and H is the height of the wall above final grade. A minimum L/H ratio of 0.7 will be required for global stability where no surcharge loading is needed.
- A minimum embedment of wall of 1.5 m will be required.
- The long-term target FOS is equal to 1.5.
- The short-term (after excavation and end of construction) target FOS is equal to 1.3.
- The groundwater table increases on average by 1.5 m in the long-term analysis.
- Soil units are homogenous.

4.2.7 Soil Parameters

The soil parameters used in the stability analysis are provided in **Table 4-1** below. For the purpose of the analysis, the engineered clay fill was assumed to consist of reworked clay till soils from the site.

Table 4-1 Soil Parameters

Material	Unit Weight (kN/m ³)	Effective Friction Angle	Effective Cohesion (kPa)	B-Bar (for short term analysis after construction of MSE wall)	Cohesion (kPa) (for short term analysis after shear key excavations)
Clay Fill	20	28	5	0.2	50
Clay Till	20	28	5	0.2	50
Clay Colluvium	18	25	0	0.4	30
Sand	20	32	0	-	-
MSE Wall Fill	20	30	200 ¹	-	-
Shear Key (Gravel)	21	35	0	-	-
Disturbed Bedrock	21	14	0	0.4	75
Sheared Zone (Bedrock)	21	14	0	0.4	-
Softened Bedrock	21	25	0	0.4	100
Intermediate Bedrock	21	25	25	0.4	150
Upper Competent Bedrock	21	25	50	0.4	200
Competent Bedrock (Infinite Strength)	21	-	-	0.4	-

¹ Should be evaluated during detailed design.

GEOTECHNICAL INVESTIGATION REPORT

Discussion and Recommendations
February 24, 2017

4.2.8 Groundwater Conditions

The groundwater levels used for stability analyses were based on the highest groundwater levels measured in the standpipes and vibrating wire piezometers installed in the boreholes. In general, the groundwater runs downslope towards the creek at or near the clay till-bedrock interface eventually reaching river level. Groundwater levels were increased on average by about 1.5 m for the long term (drained) analysis.

4.2.9 Results of Slope Stability Analyses

The results of the slope stability analyses are presented in **Appendix E. Table 4-2** below summarizes the slope stability analysis results for the end of excavation scenario.

Table 4-2 Summary of Slope Stability Analyses Results After Excavation of Shear Key

Section	Factor of Safety (FOS) At End of Shear Key Excavation	Acceptance Criteria Met?
A2	2.8	Yes
A3	1.9	Yes
B1	2.0	Yes
B2	1.5	Yes
C3	2.7	Yes
D1	2.1	Yes

Table 4-3 below summarizes the slope stability analysis results for the shear key option at the end of construction (EOC) and for long term stability.

Table 4-3 Summary of Slope Stability Analyses Results

Section	Factor of Safety (FOS)		Acceptance Criteria Met?
	End of Construction (EOC) of MSE Wall	Long Term	
A1	1.9	2.0	Yes, with piles
A2	1.3	1.5	Yes
A3	1.5	1.5	Yes
B1	1.4	1.5	Yes
B2	1.5	1.5	Yes
B3	1.5	1.5	Yes
B4	1.3	1.5	Yes
C1	1.4	1.5	Yes
C2	1.5	1.5	Yes
C3	1.4	1.5	Yes
D1	1.4	1.5	Yes
D2	1.3	1.5	Yes
D3	1.4	1.5	Yes

GEOTECHNICAL INVESTIGATION REPORT

Discussion and Recommendations
February 24, 2017

4.2.10 Slope Stability Conclusions

Based on the results of the slope stability assessment, we provide the following conclusions and recommendations.

- Northwest wall (A-sections): The reinforcement should be 16 m wide at the full height portion of the wall with a 16 m wide shear key installed to 5 m below the base of the wall up to at least the midpoint distance of the wall. A minimum wall embedment of 1.5 m should be maintained. Reinforced cast in place concrete piles, 1.2 m diameter will be needed as indicated in sections A1 to achieve the acceptable factors of safety. The transition from shear key support to the pile support is estimated to be 15 m from section A1. The number of piles, the depth and spacing are shown on cross-section A1.
- Southeast wall (B-sections): At full height, the reinforcement width should be 16 m with a 16 m shear key installed to 5 m below the base of wall. For wall heights 12 m or less, a 14 m wall with a 14 m wide shear key installed to 3 m below the base of wall will be required. For wall heights 10 m or less, a 15 m wall with a 15 m wide shear key installed to 6 m below the base of wall will be required. For wall heights 4 m or less, a 12 m wall with a 12 m wide shear key installed to 4 m below the base of wall will be required. A minimum wall embedment of 1.5 m should be maintained.
- Northeast wall (C-sections): At full height (adjacent to the culvert), the reinforcement width should be 14 m with a 14 m shear key installed to 4 m below the base of wall. For wall heights 10 m or less, a 13 m wall with a 13 m wide shear key installed to 5 m below the base of wall will be required. For wall heights 6 m or less, an 8 m wall with a 8 m wide shear key installed to 2 m below the base of wall will be required. A minimum wall embedment of 2 m should be maintained.
- Southwest wall (D-sections): At full height (adjacent to the culvert), the reinforcement width should be 14 m with a 13 m shear key installed to a depth of 5 m below the base of wall. For wall heights 9 m or less, a 14 m wall with a 14 m wide shear key installed to a depth of 4 m below the base of wall will be required. For wall heights 5 m or less, a 6 m wall with a 6 m wide shear key installed to 3 m below the base of wall will be required. A minimum wall embedment of 2 m should be maintained.

The design described above is based on the known locations of slickenslides in relation to various walls. The dimensions of the shear keys as proposed in the present design are largely controlled by the location of slickenslides. Therefore, the above conclusions will need to be refined during detailed design with additional boreholes as well as observations made during construction.

GEOTECHNICAL INVESTIGATION REPORT

Discussion and Recommendations
February 24, 2017

4.2.11 Alternative Designs

The MSE walls with shear key are considered suitable for most of the footprint (except Section A1) of the MSE wall from a design and a technical perspective. However, the large excavations for shear keys and removals of material at the toe of slopes might trigger larger failures, which can significantly impact the construction schedule of this project. Therefore, Stantec has also considered other options in an attempt to reduce and/or minimize this risk. It should be noted that these other options were not analyzed to the same extent as the option of shear key with localized section supported on piles. Therefore, only a brief summary of preliminary analysis done for these alternatives is presented below.

Stantec considered slope stabilization using CFA piles combined with smaller shear keys. Preliminary recommendations for this option include four (4) rows of piles at full height and tapering off to no piles as the wall height is reduced. A pile diameter of 1200 mm will be required with a minimum of 2% steel reinforcement. More detailed recommendations can be provided during detailed design if this option is preferred over the shear key option.

The use of lightweight fill was also considered to reduce the footprint of the shear key, length of reinforcement required, and construction risk. Lightweight fill materials considered included bottom ash and Cematrix. Bottom ash would be placed as opposed to clay fill to reduce the driving force behind the MSE wall. However, environmental concerns are inherent in the use of bottom ash and would need to be considered. Additionally, analysis using bottom ash fill did not reduce the footprint of the shear key by an appreciable amount and therefore had limited reduction in risk and cost.

Analysis using Cematrix was also considered for lightweight fill option. The use of Cematrix significantly reduced the depth and width of shear key and is considered a feasible option. However, this option is highly dependent on the b-bar response during construction and the MSE wall fill placement might require construction to be temporary stopped to let the dissipation of pore water pressure to occur prior to continuing with adding additional fill. This might impact the schedule of the project. Alternatively, sand drains may be constructed during construction to allow for pore pressure dissipation. Using Cematrix would likely increase the cost of construction. A detailed cost-benefit analysis should be conducted during detailed design.

GEOTECHNICAL INVESTIGATION REPORT

Discussion and Recommendations
February 24, 2017

4.2.12 Continuous Flight Auger Piles (CFA)

For preliminary design, CFA concrete piles may be designed with the factored shaft resistance values provided in **Table 4-4** below. Factored toe resistance should be neglected for preliminary design.

Table 4-4 CFA Pile Design Criteria

Soil Type	Approximate Elevations (m)	Factored Shaft Resistance (kPa)	Factored End Bearing Resistance (kPa)
Colluvium	630 – 628	0	-
Disturbed Bedrock	628 - 626	24	-
Competent Bedrock	Below 626	50	-

Note: Shaft resistance should be neglected within the frost zone.

CFA piles are considered proprietary foundation systems and specialized contractors would assess the feasibility of this piling system, design the piles, and propose design loads which should be approved by the structural and geotechnical engineers.

A local piling contractor experienced in the design and use of this type of pile should be consulted to determine their feasibility at this site.

4.3 SETTLEMENT PARAMETERS FOR MSE WALL

Settlement resulting from the application of new loads associated with construction of engineered fills and the loading conditions of the MSE wall and culvert are expected. Preliminary settlement parameters are provided in **Table 4-5** below.

Table 4-5 Preliminary Settlement Parameters

Material	M _v (kPa ⁻¹)	E' (MPa)
Disturbed Bedrock	1x10 ⁻⁴ to 2x10 ⁻⁴	5 to 10
Softened Bedrock	6x10 ⁻⁵ to 7x10 ⁻⁵	45 to 50
Upper Competent Bedrock and Competent Bedrock	3x10 ⁻⁵ to 4x10 ⁻⁵	90 to 100

It was assumed that the subgrade preparation recommendations in **Section 4.2.1** will be followed to reduce the potential amount of settlement. A simple settlement analysis was carried out using methods outlined in CANFEM, 2006 for a 16 m high wall. A vertical settlement in the range of 120 mm to 140 mm at the top of the wall has been estimated. It is recommended that detail deformation analysis using FLAC software should be carried out to estimate both vertical and lateral deformation of the walls.

GEOTECHNICAL INVESTIGATION REPORT

Discussion and Recommendations
February 24, 2017

4.4 EMBANKMENT FILL BEHIND MSE WALLS

Outside of the MSE granular fill mass, the remainder of the fill for the road embankment will consist of well compacted clay fill. Granular drainage blankets will be required at certain locations on the slopes prior to placement of the clay fill to reduce the risk of pore pressure buildup within the slope.

4.4.1 Subgrade Preparation

Any organics, un-suitable or soft material on the valley bottom below and behind MSE walls will require removal prior to placement of the embankment fill. Following stripping and excavation, the exposed subgrade surfaces should be scarified to a depth of 300 mm and moisture conditioned to within 0% to 2% of optimum and compacted to 98% of Standard Proctor Maximum Dry Density (SPMDD). Optimum moisture content and SPMDD should be determined in accordance with the ASTM D698.

Prepared subgrade surfaces should be proof-rolled using heavy equipment such as a loaded dump truck or water truck and witnessed by experienced geotechnical personnel. All soft areas identified during the proof roll must be sub-excavated to competent material (or to a maximum depth of 600 mm) and replaced with approved Engineered Fill. Use of geotextiles may be warranted for separation. To promote subgrade uniformity, soft area repair should be carried out using mineral soil of a similar nature to the native subgrade soils. Repair of soft areas using granular materials may result in undesirable ponding and retention of water within the gravel in the repair areas. Soft area repairs using gravel should therefore be carried out only with due consideration given to proper drainage of the repaired area.

4.4.2 Site Grading and Drainage

It is anticipated that site grading will be required in the development areas in order to achieve subgrade design elevations. Positive drainage away from the slopes, MSE walls, culvert, and roadways should be designed in order to reduce accumulation of surface runoff to prevent ponding and possible softening of the subgrade and soils on excavated slopes. Excess water should be drained or pumped from the site as quickly as possible, both during and after construction.

The finished grade should provide surface drainage away from all structures. Landscaped areas should be graded to slope water away from the slopes, MSE walls, culvert, and roadway. A minimum gradient of 2% should be used wherever possible.

Where excavations are required, **Section 4.2.2** should be followed.

GEOTECHNICAL INVESTIGATION REPORT

Discussion and Recommendations
February 24, 2017

4.5 PAVEMENT STRUCTURE

The following pavement structural design is intended for the proposed new section of Aurum Road. Procedures/methodologies used in the development of the design process are:

- Alberta Transportation and Utilities, *Pavement Design Manual*, 1997;
- Alberta Transportation and Utilities, *Design Bulletin #15*, 2003;
- Alberta Transportation and Utilities, *Design Bulletin #13*, 2012;
- Alberta Transportation and Utilities, *Design Bulletin #77*, 2013;
- AASHTO *Design Guide for the Design of Pavement Structures*, 1993;
- City of Edmonton *Construction Specifications*, 2015.

The initial construction consists of three traffic lanes: two in the westbound direction, and one in the eastbound direction. Ultimately, the roadway will consist of three driving lanes in each direction.

Traffic estimates provided included an AADT of 9,000 vpd with 5,000 vpd in the two westbound lanes and 4,000 vpd in the single eastbound lane. Truck traffic was estimated to be 5 percent. Because the roadway accesses a heavy industrial area, the truck traffic and associated truck factors used in the design are as follows:

- 25 percent 2 and 3 axle trucks, TF = 0.881
- 25 percent 4 axle trucks, TF = 2.073
- 50 percent 6 axle trucks, TF = 5.500

The pavement design parameters are based on Alberta Transportation and Utilities requirements as follows:

Item	Design Parameter
Design Life	20 Years
Annual Traffic Growth	5 Percent
Directional Distribution (West/East)	55/45
Lane Distribution (Westbound)	85/15
Design ESAL's	8.9×10^6
Reliability	90 percent
Standard Deviation	0.45
Initial Serviceability	4.2
Terminal Serviceability	2.5
Subgrade Modulus	32 MPa
Structural Coefficient, Asphalt Concrete	0.40
Structural Coefficient, Granular Base	0.14
Drainage Coefficient, Granular Base	1.0
Required Structural Number	144



GEOTECHNICAL INVESTIGATION REPORT

Discussion and Recommendations
February 24, 2017

Typically, for staged construction, the final surface is applied two years following construction and would apply to both alternative structures provided below. As deep (approximately 18 m) fill is proposed at the stream crossing on the east portion of the roadway, some longer term settlement should be anticipated and it may be desirable to delay the placement of the final surface asphalt for a longer period of up to five years. Pavement structure Alternative #2, with thicker initial asphalt concrete, is provided for this application. Both alternatives structures have equivalent structural capacity.

The proposed alternative pavement structures are as follows:

Layer/Item	Alternative #1	Alternative #2
ACP, 2 nd Stage, SGC HT-10, PG 58-37	60 mm	60 mm
ACP, 1 st Stage, SGC HT-10, PG 58-34	60 mm	60 mm
ACP, 1 st Stage, SGC HT-20, PG 58-34	80 mm	100 mm
GBC, Designation 3-20	475 mm	400 mm
Structural Number	146	144

4.5.1 Backfill and Compaction Requirements

Engineered fill should consist of clean mineral soil free from organics or other deleterious materials. The native clay till are considered suitable for reuse as Engineered Fill with proper moisture conditioning.

Drying or wetting of the site soils will also be required during periods of heavy rain, hot weather, or in the event that excavated material is allowed to dry excessively prior to reuse. Alternatively, mixing of dry and wet soils to reach the optimum moisture content may be considered provided that qualified geotechnical personnel approve the mixed soil prior to use.

All fill materials should be placed in lifts having a thickness such that the compaction equipment can achieve the required density, but not exceed 300 mm. Compaction requirements for the various fill materials are presented in **Table 4-6**.

GEOTECHNICAL INVESTIGATION REPORT

Discussion and Recommendations
February 24, 2017

Table 4-6 **Compaction Requirements**

Material	Location	Compaction Requirement	Moisture Content Range
Engineered fill (fine-grained)	>1.5 m below subgrade level	98% SPMDD	0 to 2% above OMC
Engineered fill (fine-grained)	<1.5 m below subgrade level	100% SPMDD	0 to 2% above OMC
Engineered fill (coarse-grained)	>1.5 m below subgrade level	98% SPMDD	±2% OMC
Engineered fill (coarse-grained)	<1.5 m below subgrade level	100% SPMDD	±2% OMC
Granular subbase (GSBC)	Roadway and parking areas	100% SPMDD	±2% OMC
Granular base (GBC)	Roadway and parking areas	100% SPMDD	±2% OMC
General fill	Landscaped areas	92% SPMDD	±3% OMC
Asphalt Concrete Pavement (ACP)	Roadway and parking areas	98% of a 75 blow Marshall	--
Note: 1. SPMDD – Standard Proctor Maximum Dry Density (ASTM D698) 2. OMC – Optimum Moisture Content 3. General fill does not include the area 5 m away from the MSE wall face			

The native soils can also be used in non-structural and landscaped areas with proper moisture conditioning and compaction (minimum 92% of SPMDD unless otherwise specified). Landscaped areas in front of the MSE wall should follow the compaction requirements as specified in **Table 4-6** except when within 5 m away from the wall face. Additional details for backfill and compaction requirements can be found in City of Edmonton Specification for Trench Backfill, Section 02318, Volume 2, Roadways, 2015.

Bedding materials for utilities should be specified and placed in accordance with the pipe design requirements. Utility trench backfill should consist of compacted engineered fill, similar to, or the same as the excavated soils. Different abutting materials within the frost zone will require a frost taper in order to minimize differential frost heaving.

All imported fill materials should be tested and approved by a geotechnical engineer prior to delivery to the site.

GEOTECHNICAL INVESTIGATION REPORT

Discussion and Recommendations
February 24, 2017

4.6 EROSION CONTROL MEASURES

During construction, temporary erosion control should be implemented through the use of typical Best Management Practices including silt fences, erosion control blankets, seeding and/or vegetation covers. A site specific temporary erosion control plan should be required and followed by the Contractor.

Erosion and scour protection on all exposed slopes below and above the design creek flood level will be an important design element to address. The design of the wildlife and pedestrian benches, and the north and south head slopes and abutment areas should take into account the design flood conditions including the potential for beaver activity and ice jams.

Permanent erosion protection of the approach embankment sideslopes should also be carried out as early as possible to reduce the erosion potential while the remainder of the crossing is being constructed. Topsoil and seeding is considered suitable for the sideslopes and should be placed as soon as final grading of the embankments is complete.

4.7 GEOTECHNICAL INSTRUMENTATION AND MONITORING DURING CONSTRUCTION

The stability of the MSE wall is sensitive to the potential excess pore pressures developed in foundation soils/bedrock and the embankment fill during construction and post construction. A geotechnical instrumentation and monitoring program is recommended to verify that the assumptions made in the MSE wall design (i.e. global stability analyses) are consistent with the subsurface conditions and performance of the foundation soils and embankment fills during the construction process.

The MSE wall construction monitoring should include the following:

- Inspection and monitoring by geotechnical personnel during the subgrade preparation stages will be critical. It will be important to ensure that the subgrade preparation recommendations are followed;
- Measurement of the groundwater table before construction commences;
- Monitoring of pore water pressure using piezometers (vibrating wire or pneumatic) in the foundation clay soils, bedrock and in the embankment fills during the embankment and MSE wall construction process;
- At the time of installation of the piezometers (before construction of MSE wall), measurements of undrained shear strength with depth should be conducted in order to confirm the assumptions made in the slope stability analyses. As boreholes will be needed for piezometer installation, sampling and testing can be completed concurrently;

GEOTECHNICAL INVESTIGATION REPORT

Discussion and Recommendations
February 24, 2017

- Monitoring of settlement monuments and settlement plates during the MSE wall construction process. Vibrating wire settlement plates are recommended as they do not cause any interference with construction activities.;
- Monitoring of settlement of the driving surface at selected points behind the wall; and,
- Monitoring of lateral movements using slope inclinometers in the embankment fills and MSE walls during the embankment and MSE wall construction process.

Details regarding the type, location and number of instruments can be provided upon request. A detailed monitoring program should be developed once the detailed design of the embankment and MSE wall has been completed.

The influence from the MSE wall construction on buried infrastructure such as existing or future underground utilities below or in the immediate vicinity of the MSE wall and embankment should also be considered in the design and construction.

4.8 ARCH CULVERT FOUNDATIONS

Due to the large amount of fill that will be placed above the arch, high loads must be carried by the foundations. Due to the presence of colluvium and or softened clay shale below the arch foundations, it will be necessary to support the loads on deep foundations. It is understood that driven steel H-Piles are the preferred pile type by the culvert designers to carry the loads down to more competent bedrock material below the ravine bottom. A preliminary vertical load of 3000 kN/m was provided to Stantec by the culvert designers with a horizontal load assumed at 10% of the vertical load. Furthermore, the loading will depend on the final shape of the arch. Stantec's analysis below considered the information above.

4.8.1 Driven Steel Piles

The resistance of piles against axial compressive loads is derived from the combination of the shaft resistance (skin friction) along the pile shaft and the end bearing resistance at the pile toe or tip. For the design of driven steel pipe and H-piles, the recommended unfactored (ultimate) unit shaft resistance and unit end bearing resistance values are given in **Table 4-7**.

GEOTECHNICAL INVESTIGATION REPORT

Discussion and Recommendations
February 24, 2017

Table 4-7 Recommended Unfactored Shaft and End Bearing Resistance for Driven Steel Piles

Soil Type	Approximate Elevations (m)	Unfactored (Ultimate) Shaft Resistance (kPa)	Unfactored (Ultimate) End Bearing Resistance (kPa)
Colluvium	630 – 628	0	0
Disturbed Bedrock	628 - 626	60	0
Competent Bedrock	Below 626	150	3000

For steel H-piles, the surface area should include the exterior sides of two flanges plus twice the depth of the web. The end bearing resistance should be applied to the gross area at the pile tip, which may be taken as the cross-sectional area of the rectangle bounded by the flanges in the case of H-piles.

To determine the factored geotechnical resistance of the piles in compression at ultimate limit states (ULS), a geotechnical resistance factor of 0.4 should be applied to the unfactored (ultimate) shaft and end bearing resistances given in **Table 4-7**. If dynamic testing (i.e. Pile Driving Analyzer (PDA) monitoring and Case Pile Wave Analysis Program (CAPWAP) analyses) is carried out on a representative portion of the production piles, the geotechnical resistance factor used in the design could be increased from 0.4 to 0.5 provided the dynamic testing indicated that the ultimate resistance used in the design was achieved in the field. Typically, the portion of the piles that should be tested would be 5 to 10 percent of the total number of piles.

For axial loading, the minimum allowable centre-to-centre pile spacing should be taken as 3 pile diameters. This minimum spacing is given to ensure the piles act as single piles, with no group interaction effects with regards to axial resistance. For piles spaced less than 3 pile diameters, the pile resistance should be reduced by a group reduction factor. We can provide further guidance in terms of group interaction effects once more details are known about the pile types, loads, and pile group layout, etc.

The resistance of piles to uplift loads will be provided solely by shaft resistance. To determine the factored geotechnical resistance of the piles in uplift at ULS, a geotechnical resistance factor of 0.3 should be applied to the unfactored (ultimate) shaft resistances given in **Table 4-7**. The design of piles for external uplift loads should be separate from the design for upward frost jacking forces. The rationale for this is that the adfreeze bond over the frost penetration depth will resist the external uplift loads.

GEOTECHNICAL INVESTIGATION REPORT

Discussion and Recommendations
February 24, 2017

In order to increase the likelihood that piles can be driven to the required compressive resistances, the factored compressive load on a steel pile should be limited to a value no greater than $0.33F_yA_s$, where F_y is the yield strength of steel, and A_s is the cross-sectional area of the pile. Adherence to this recommendation will also help to control driving stresses, as past experience has indicated that if the factored compressive load is limited to this maximum value, the likelihood of structural damage caused by pile driving process will also be reduced.

It should also be noted that cobbles were noted within the creek areas during the geotechnical investigation. Driving shoes may be required during pile installation.

4.8.2 Frost Consideration for Piles

Piles that support exterior facilities or components or structures that will be outside the influence of any beneficial heat transfer will be subjected to adfreezing stresses acting along the pile shafts within the depth of frost penetration. Where the bases of the unheated facilities extend below finished grade, frost heave forces acting on the underside of pile caps also need to be considered.

Although difficult to quantify, frost heave forces could be 200 kPa or greater. The anticipated loading above the pile cap may be sufficient in resisting frost heave forces. Void forms should not be installed beneath pile caps due to the pile caps being installed lower than the anticipated groundwater depth. The finished grade adjacent to each pile cap should be capped with well compacted clay and sloped away so that the surface runoff is not allowed to infiltrate the ground.

Resistance to adfreezing stresses (frost jacking) on pile shafts will be provided by the skin friction below the depth of frost penetration, the weight of the pile and by sustained compressive loads. For design purposes, an adfreezing uplift pressure of 100 kPa in the soils applied over the design depth of frost penetration of 2.5 m should be used.

4.8.3 Pile Settlement

The settlement of a single pile depends on the applied compressive load, strength-deformation properties of the foundation soils, load transfer mechanism, and the relative proportions of the loads carried by shaft resistance and end-bearing resistance. In estimating the settlement of a single pile, it is assumed that the serviceability load on the piles will be 40 to 50 percent of unfactored (ultimate) geotechnical resistance of the pile. For preliminary design, the estimated settlement of piles under Serviceability Limit State (SLS) would be in the range 0.5 to 1 percent of the shaft diameter plus the elastic shortening of the pile due to the compressive load acting on the pile. It should be noted that more realistic estimates of settlement could be provided once the loads, pile type and the relative locations of the piles on the site are known.

GEOTECHNICAL INVESTIGATION REPORT

Discussion and Recommendations
February 24, 2017

4.8.4 Negative Skin Friction and Downdrag Loads on Piles

Regarding the design of driven steel piles for this project, consolidation of the underlying foundation soils from the embankment loading will result in down-drag forces on the piles through negative skin friction. The location of where the negative skin friction changes over to positive shaft resistance is defined as the neutral plane. The location of the neutral plane governs both the maximum load in the piles and more importantly the settlement of the pile.

The design of the pile should consider the structural axial capacity, the settlement, and the geotechnical axial capacity of the piles. The downdrag (negative skin friction) increases the structural loads in the pile and thus has to be accounted for when evaluating the structural ultimate limit state of the piles. The downdrag also increases the pile settlement and therefore should be accounted for when evaluating the serviceability limit state of the pile. However, the downdrag has no effect on the geotechnical axial capacity of the pile.

The structural capacity of the pile should be assessed using the factored dead and drag loads and also analyzing the factored dead loads and live loads. The greater of these combinations will govern the structural capacity of the pile.

4.8.5 Installation and Monitoring of Driven Steel Piles

Preliminary sizing of driving hammers for steel piles can be carried out assuming that hammer energy in the range of 450 to 600 J per blow would be required for each square centimeter of steel in the pile cross-section. This criterion is only a preliminary guide to estimate the size of the pile driving hammer that would be required. The ability of a pile driving hammer to drive the piles to the required capacity should be confirmed using wave equation analysis (WEAP) once details regarding the proposed hammer configuration, pile load, pile diameter and the wall thickness are known. Pile termination criteria should be established using wave equation analysis for the given design loads. To limit structural damage, the piles should not be driven beyond practical refusal, which may be taken as 10 to 12 blows per 25 mm penetration for the last 250 mm of penetration.

It is recommended that piles within a group be driven from the center of the group outwards. Where end bearing has been included in the design, or where the piles are driven using a termination criterion, the elevation of the tops of piles previously installed should be monitored as adjacent piles are driven in order to determine if heaving of the previously installed piles has occurred. Piles that have heaved must be re-driven to at least their initial embedment depths.

Prior to installation, piles should be inspected to confirm that the appropriate material specifications are satisfied. Piles should be free from protrusions which could create voids in the soil around the pile during driving. If a driving shoe is used, it must not protrude beyond the outside diameter of the pile.

GEOTECHNICAL INVESTIGATION REPORT

Discussion and Recommendations
February 24, 2017

Monitoring of the pile installations by qualified personnel is recommended to confirm that the piles are installed in accordance with design assumptions and that driving criteria are satisfied. For each pile, a complete driving record showing the number of blows per each 250 mm of penetration, and the hammer energy or stroke used at various stages of the driving process should be recorded, and reviewed on a daily basis during driving by a qualified geotechnical engineer.

4.8.6 Lateral Resistance of Piles

Lateral load analyses of single piles were undertaken using *LPILE 2016* (by Ensoft Inc.) computer software program, which is a tool for analyzing the behavior of a single pile subjected to lateral loads. This analytical procedure estimates the lateral load-displacement behavior using a finite difference technique based on elastic beam column theory and p-y (soil reaction-displacement) curves. Using the methodology of Reese, the behavior of the soil surrounding the laterally loaded shaft is modeled by lateral load-transfer functions referred to as p-y curves. The soil reaction (p) is related to the shaft deflection (y) for various depths below the ground surface. In general, these curves are nonlinear and depend on several parameters, including depth, shaft diameter and soil strength. The program computes deflection, bending moment and shear profiles at specified intervals along the length of the pile.

Steel HP360 x 132 pile sections with an embedment length of 18 m was analyzed. The pile heads were assumed to be located at grade (elevation 630 m). The piles were assumed to be restrained from rotation and translation (fixed-head) with a range of lateral loads applied at the pile head.

The analysis was undertaken for a soil model developed based on the available borehole information. The soil model for the LPILE analysis is summarized in **Table 4-8**.

Table 4-8 Soil Model Inputted for LPILE Analysis

Depth (m)	Soil	Unit Weight (kN/m ³)	Undrained Cohesion (kPa)	E ₅₀
0 – 2	Soft Clay (Matlock)	8	25	0.02
2 – 4	Stiff Clay without free water	10	80	0.006
4 – 6	Stiff clay without free water	10	300	0.004
6 – 18	Stiff clay without free water	10	383	0.004

The results from the lateral pile analyses are provided in **Appendix F**. All analysis results are presented in terms of unfactored loads and unfactored resistances. The lateral deflections given were those calculated at the pile heads for the assumed pile lengths. Based on the results, piles shorter than the embedment lengths noted above may result in larger deflections than those given in the figures. If shorter lengths are proposed then the analyses should be re-evaluated based on the available information. For fixed headed piles, the calculated maximum bending moments were at the pile heads.

GEOTECHNICAL INVESTIGATION REPORT

Discussion and Recommendations
February 24, 2017

The following additional assumptions were also considered in the analysis:

- No reduction in steel wall thickness due to corrosion was taken into consideration
- The surrounding ground surface would be horizontal and protected from erosion and that loss of support from soils below the design grade would not occur. Therefore, as a preliminary guide, the results presented should be applied only if the grade surrounding the piles is maintained horizontal for a distance from the pile of at least 6 times the diameter of the pile. If this condition is not satisfied then additional analyses would be required
- Any excavations adjacent to piles after the piles are installed must be backfilled and compacted in accordance with the recommendations provided in **Section 4.5.1**. Oversized pre-bored holes or hydro-vac excavations created prior to driving piles would reduce the lateral capacity of piles and should be filled with a cement-grout immediately following pile installation

4.9 LIFT STATION

Deep well excavations with an inside diameter of 9 m and up to 12.5 m deep (approximate elevation of 636 m) is anticipated for construction of the lift station. The lift station can be constructed using braced excavation systems such as driven sheet pile walls or sunken caissons. It is understood that a raft foundation is planned at the base of the lift station.

4.9.1 Braced Excavations

4.9.1.1 Driven Steel Sheet Pile Wall

Steel sheet pile walls are normally driven into the ground in pairs using a pile-driving hammer or vibratory hammer similar to those used to drive foundation piles. Most sheet pile walls include additional lateral support, using internal bracing or tieback anchors. The additional support reduces the flexural stresses and lateral movements in the wall and promotes less settlement in the backfill.

It is assumed that the sheet piles will be required only for the excavation and will be removed after construction. The design of the braced excavation system is generally carried out by the contractor. It is recommended that the sheet piles designed to be installed deeper than the anticipated depth of excavation (minimum 2 m into bedrock or to practical refusal) to help in resisting any failures of the adjacent soils at the bottom of the excavation. All construction equipment (excavators, stockpiled fill, or any other piece of equipment or load) should stay well away from the top of sheet pile walls during the excavation.

It should be noted that, cobbles were observed along the slopes of the site. The presence of rocks of different sizes may impact the installation of the sheet pile wall.

GEOTECHNICAL INVESTIGATION REPORT

Discussion and Recommendations
February 24, 2017

Based on the observations made during the drilling program and the measured groundwater levels (12.4 m below existing grade), construction of the lift station should be above the water table. Any seepage entering the excavations, should be immediately pumped out. Dewatering of excavations will be dependent upon weather conditions and the time of year of construction. If groundwater is encountered, it is expected that groundwater may be controlled by sump and pump methods.

Lateral earth pressure for the sheet pile walls may be calculated using the parameters listed in **Table 4-9**.

Table 4-9 Lateral Earth Pressure Parameters

Parameters	Clay Till	Sand	Rafted Bedrock	Bedrock
Unit Weight, γ' (kN/m ³)	20	20	21	21
Angle of Internal Friction, Φ' (°)	28	32	25	25
Undrained Shear Strength, C_u (kPa)	100	-	200	200

4.9.1.2 Sunken Caissons

Sunken caissons where cast-in-place reinforced concrete rings can also be used to provide bracing support for the lift station construction. This method will leave the caissons in place ultimately becoming part of the well structure. Lateral earth pressure for the caissons may be calculated using the parameters listed in **Table 4-9**.

4.9.2 Bearing Capacity at Base of Excavation

The raft footing at the base of the lift station will be founded at approximately elevation 636 m (12.5 mbgs) within the non-raftered bedrock layer. For preliminary design of footing foundations, a factored geotechnical resistance at Ultimate Limit States (ULS) of 500 kPa is recommended. A geotechnical resistance factor of 0.5 was applied to the ultimate bearing pressure to determine the above factored geotechnical resistance. For serviceability Limit States (SLS) design of footings, a reaction of 350 kPa for 25 mm of settlement is recommended in the non-raftered bedrock.

Subgrade preparation recommendations outlined in **Section 4.4.1** should be followed.

4.9.3 Unbraced Shallow Excavations

Shallow excavations may be required during construction of the lift station. Temporary shallow excavations should follow the recommendations provided in **Section 4.2.2**.

GEOTECHNICAL INVESTIGATION REPORT

Discussion and Recommendations
February 24, 2017

4.9.4 Trench Backfill

Bedding materials for utilities should be specified and placed in accordance with the pipe design requirements and meet applicable City of Edmonton Design and Construction Specifications. Utility trench backfill should consist of compacted engineered fill, similar to, or the same as the excavated soils. Different abutting materials within the frost zone will require a frost taper in order to minimize differential frost heaving.

It is suggested that the bedding material be placed around the service pipes with a minimum of 300 mm cover on all sides of the pipe.

All backfill material placed within roadways, parking areas, sidewalks, must conform to the City of Edmonton Roadways Design Standard and Construction Specifications. Compaction requirements should follow those provided in **Table 4-6**.

For settlement sensitive utilities, the backfill should be placed in 150 mm thick loose lifts and compacted to a minimum of 100% SPMDD.

4.10 BORROW MATERIAL AND MATERIAL RE-USE

It is anticipated that clay till excavated from the construction of the pond will be re-used on site. This material should be free of organics, cobbles, and boulders. The clay till in the pond area are generally at or below optimum moisture content and therefore the use of these materials may require moisture conditioning to achieve the recommended compaction standards. It should be noted that the clay till is generally sensitive to moisture and wet weather conditions, therefore, moisture conditioning needs to be implemented in a careful manner to prevent over-wetting. To reduce excess pore water pressure development and increase the strength of the engineered fill, the clay fill should be placed at the materials optimum moisture content to 2 percent dry of optimum, and compacted to a minimum of 98 percent Standard Proctor maximum dry density (ASTM D698).

Granular material selection will depend on the option selected for MSE wall construction. If shear key option is selected, a 35 degree clean granular material will be required. Otherwise, pit run gravel will be needed if light weight fill, or piles below MSE walls are selected.

4.11 CEMENT TYPE FOR SUBSURFACE CONCRETE

The water soluble sulphate results in **Table 3-3** were compared to Table 3 of the CSA A23.1 "Concrete Materials and Methods of Concrete Construction". The results indicate that the soluble sulphates are "negligible" in the soil, therefore, normal Portland cement Type 10 or GU (General Use) are suitable for concrete in contact with the soil at the site.

GEOTECHNICAL INVESTIGATION REPORT

Discussion and Recommendations
February 24, 2017

4.12 SOIL CORROSIVITY FOR STEEL PILES

As reported in **Table 3-3**, the laboratory measured resistivity values were in the range of 400 to 2,400 ohm-cm. These results indicate that the in-situ soils are in the range of "moderately corrosive" to "very corrosive" aggressiveness for soil on steel. The assessment of corrosion potential and the need for corrosion protection for steel piles over the service life of the arch culvert should be established by a corrosion specialist.

4.13 ASSUMPTIONS AND AVAILABLE INFORMATION LIMITATIONS

At the time of the preparation of this report, only 65% drawings were available. As such, a number of assumptions were made in order to develop geotechnical cross-sections, analytical models and geotechnical analysis. These assumptions made throughout this report should be reviewed by the designers to ensure that they are accurate and representative of the final design condition. If any of our assumptions are inaccurate or need to be modified, we request to be contact immediately to review our recommendations in the context of the changes or inaccuracies.

GEOTECHNICAL INVESTIGATION REPORT

Closure
February 24, 2017

5.0 CLOSURE

This Geotechnical Report has been prepared for the sole use of Aurum Industrial Development Partnership and their agents. This Geotechnical Report should not be relied upon by other parties without the express written consent of Aurum Industrial Development Partnership and Stantec.

Should any assumptions listed in the report be incorrect, Stantec should be informed immediately, so that we can re-evaluate our recommendations presented in this report.

Use of this report is subject to the Statement of General Conditions provided in **Appendix A**. It is the responsibility of Aurum Industrial Development Partnership who is identified as "the Client" within the Statement of General Conditions, and its agents to review the conditions and to notify Stantec should any of these not be satisfied. The Statement of General Conditions addresses the following:

- Use of the report
- Basis of the report
- Standard of care
- Interpretation of site conditions
- Varying or unexpected site conditions
- Planning, design or construction

We trust the information in this report meets with your requirements. Should you have any questions or require further information, please contact the undersigned at your convenience. This report was prepared by Leslie Cho, M.Eng., EIT and Mohamed Abdelrahman, M.Sc., P.Eng., PMP. Technical advice for analysis and design options was provided by by Ian Darrach, M.Eng., P.Eng. throughout the project. The report was reviewed by Arun Valsangkar, Ph.D., P.Eng.(NB). An Independent Reviewer is also being contacted considering the complex nature of the project.

STANTEC CONSULTING LTD.



Leslie Cho, M.Eng., E.I.T.
Geotechnical Engineer in Training
Tel: (780) 917-7403
Leslie.Cho@stantec.com



Mohamed Abdelrahman, M.Sc., P.Eng., PMP
Associate – Geotechnical Engineer
Tel: (780) 969-6546
Mohamed.Abdelrahman@stantec.com

APEGA Permit No.: P0258



GEOTECHNICAL INVESTIGATION REPORT

February 24, 2017

Appendix A Statement of General Conditions



STATEMENT OF GENERAL CONDITIONS

USE OF THIS REPORT: This report has been prepared for the sole benefit of the Client or its agent and may not be used by any third party without the express written consent of Stantec Consulting Ltd. and the Client. Any use which a third party makes of this report is the responsibility of such third party.

BASIS OF THE REPORT: The information, opinions, and/or recommendations made in this report are in accordance with Stantec Consulting Ltd.'s present understanding of the site specific project as described by the Client. The applicability of these is restricted to the site conditions encountered at the time of the investigation or study. If the proposed site specific project differs or is modified from what is described in this report or if the site conditions are altered, this report is no longer valid unless Stantec Consulting Ltd. is requested by the Client to review and revise the report to reflect the differing or modified project specifics and/or the altered site conditions.

STANDARD OF CARE: Preparation of this report, and all associated work, was carried out in accordance with the normally accepted standard of care in the state or province of execution for the specific professional service provided to the Client. No other warranty is made.

INTERPRETATION OF SITE CONDITIONS: Soil, rock, or other material descriptions, and statements regarding their condition, made in this report are based on site conditions encountered by Stantec Consulting Ltd. at the time of the work and at the specific testing and/or sampling locations. Classifications and statements of condition have been made in accordance with normally accepted practices which are judgmental in nature; no specific description should be considered exact, but rather reflective of the anticipated material behavior. Extrapolation of in situ conditions can only be made to some limited extent beyond the sampling or test points. The extent depends on variability of the soil, rock and groundwater conditions as influenced by geological processes, construction activity, and site use.

VARYING OR UNEXPECTED CONDITIONS: Should any site or subsurface conditions be encountered that are different from those described in this report or encountered at the test locations, Stantec Consulting Ltd. must be notified immediately to assess if the varying or unexpected conditions are substantial and if reassessments of the report conclusions or recommendations are required. Stantec Consulting Ltd. will not be responsible to any party for damages incurred as a result of failing to notify Stantec Consulting Ltd. that differing site or sub-surface conditions are present upon becoming aware of such conditions.

PLANNING, DESIGN, OR CONSTRUCTION: Development or design plans and specifications should be reviewed by Stantec Consulting Ltd., sufficiently ahead of initiating the next project stage (property acquisition, tender, construction, etc), to confirm that this report completely addresses the elaborated project specifics and that the contents of this report have been properly interpreted. Specialty quality assurance services (field observations and testing) during construction are a necessary part of the evaluation of sub-subsurface conditions and site preparation works. Site work relating to the recommendations included in this report should only be carried out in the presence of a qualified geotechnical engineer; Stantec Consulting Ltd. cannot be responsible for site work carried out without being present.

GEOTECHNICAL INVESTIGATION REPORT

February 24, 2017

Appendix B

Figures



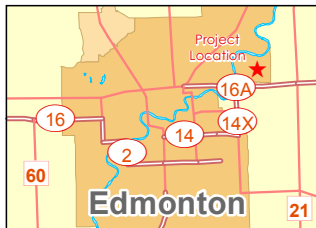
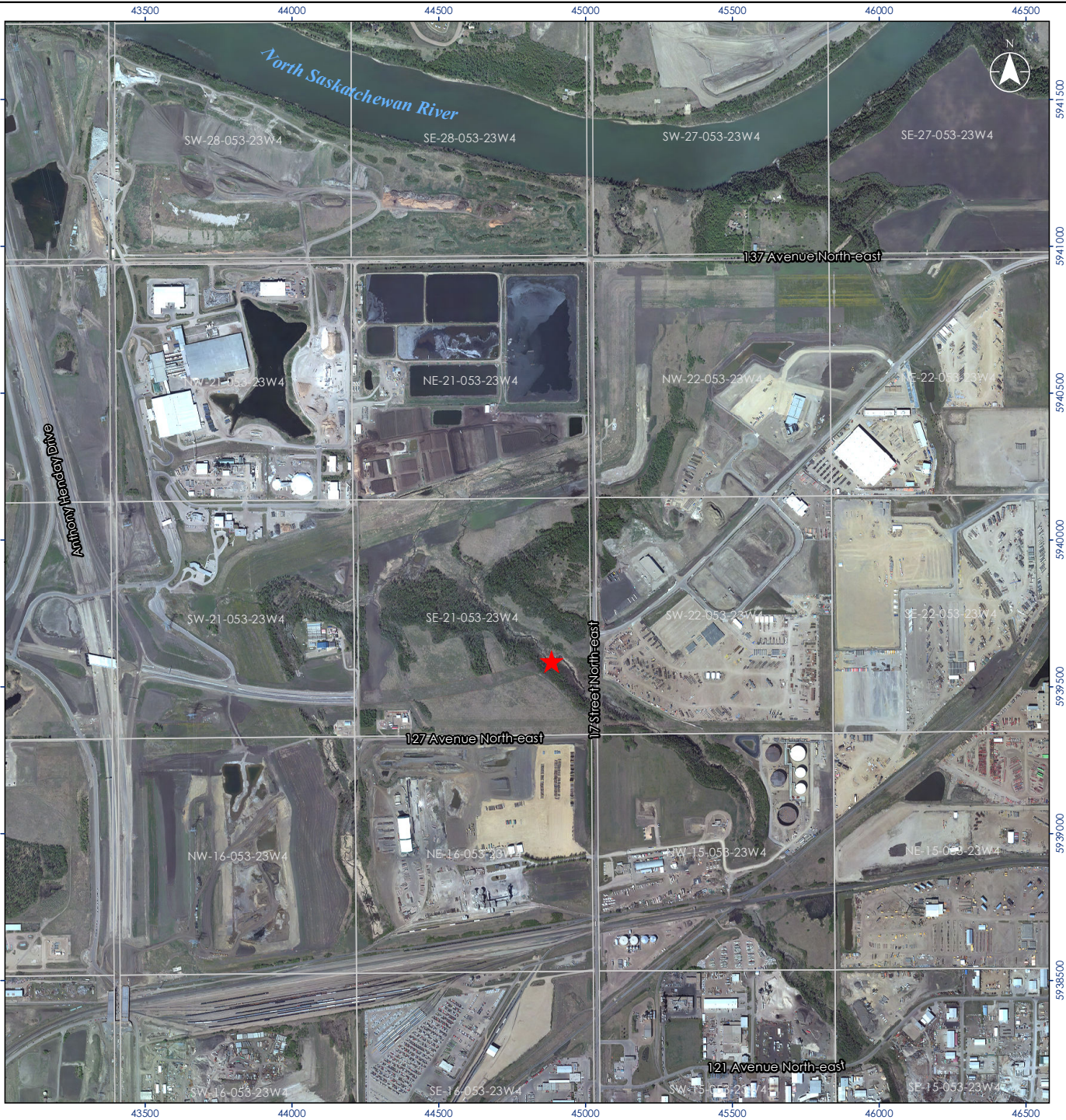

★ Project Location
 □ Quarter Section



Project Location 123312651
 12704-17 Street NE
 SE¼ 21-053-23 W4M
 Edmonton, Alberta
 Prepared by JC on 2016-07-04
 Review by MK on 2016-07-15

Client/Project
 Aurum Industrial Development Partnership
 Aurum Industrial Business Park

Figure No.
1
 Title

Site Location Plan

- Notes**
1. Coordinate System: NAD 1983 3TM 114
 2. Base features: Geogratis, ©Department of Natural Resources Canada. All rights reserved. Pipelines - 2015
 3. Imagery: City of Edmonton Transportation, 2015

Disclaimer: Stantec assumes no responsibility for data supplied in electronic format. The recipient accepts full responsibility for verifying the accuracy and completeness of the data. The recipient releases Stantec, its officers, employees, consultants and agents, from any and all claims arising in any way from the content or provision of the data.



- Borehole Location
- Borehole 2011
- Hand Auger Hole
- Aurum Road Alignment

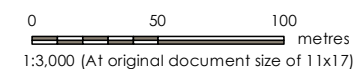

- Notes**
1. Coordinate System: NAD 1983 3TM 114
 2. Base features: Geogatis, ©Department of Natural Resources Canada. All rights reserved.
 3. Imagery: City of Edmonton Transportation, 2015

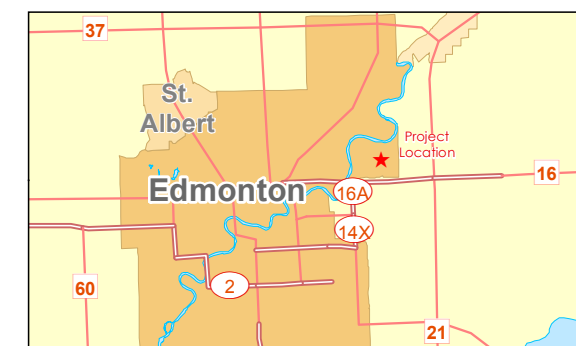

Project Location
12704-17 Street NE
SE¼ 21-053-23 W4M
Edmonton, Alberta

110219671
Prepared by JC on 2016-07-12
Review by MK on 2016-07-15

Client/Project
Aurum Industrial Development Partnership
Aurum Industrial Business Park

Figure No.

2

Title

Borehole Location Plan



Stantec Consulting Ltd.
 10160 - 112 Street
 Edmonton AB Canada
 Tel. 780.917.7000
 www.stantec.com

Copyright Reserved
 The Contractor shall verify and be responsible for all dimensions. DO NOT scale the drawing - any error omissions shall be reported to Stantec without delay. The Copyrights to all designs and drawings are the property of Stantec. Reproduction or use for any purpose other than that authorized by Stantec is forbidden.

Legend
 ● BOREHOLE LOCATION

Notes
 • 1m CONTOURS

Development Engineer: Sustainable Development			
Approvals			YY.MM
Revision	By	Appd.	YY.MM
Issued	By	Appd.	YY.MM
PROJECT MANAGER: _____	DESIGN: RW	DRAWN: EC	

Permit-Seal

Client/Project
 AURUM INDUSTRIAL
 DEVELOPMENT PARTNERSHIP

EDMONTON, AB
 Title
 BOREHOLE LOCATION PLAN
 AT CLOVERBAR CREEK CROSSING

Project No. 123312651
 Scale 1:400

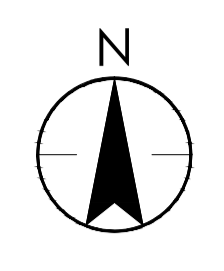
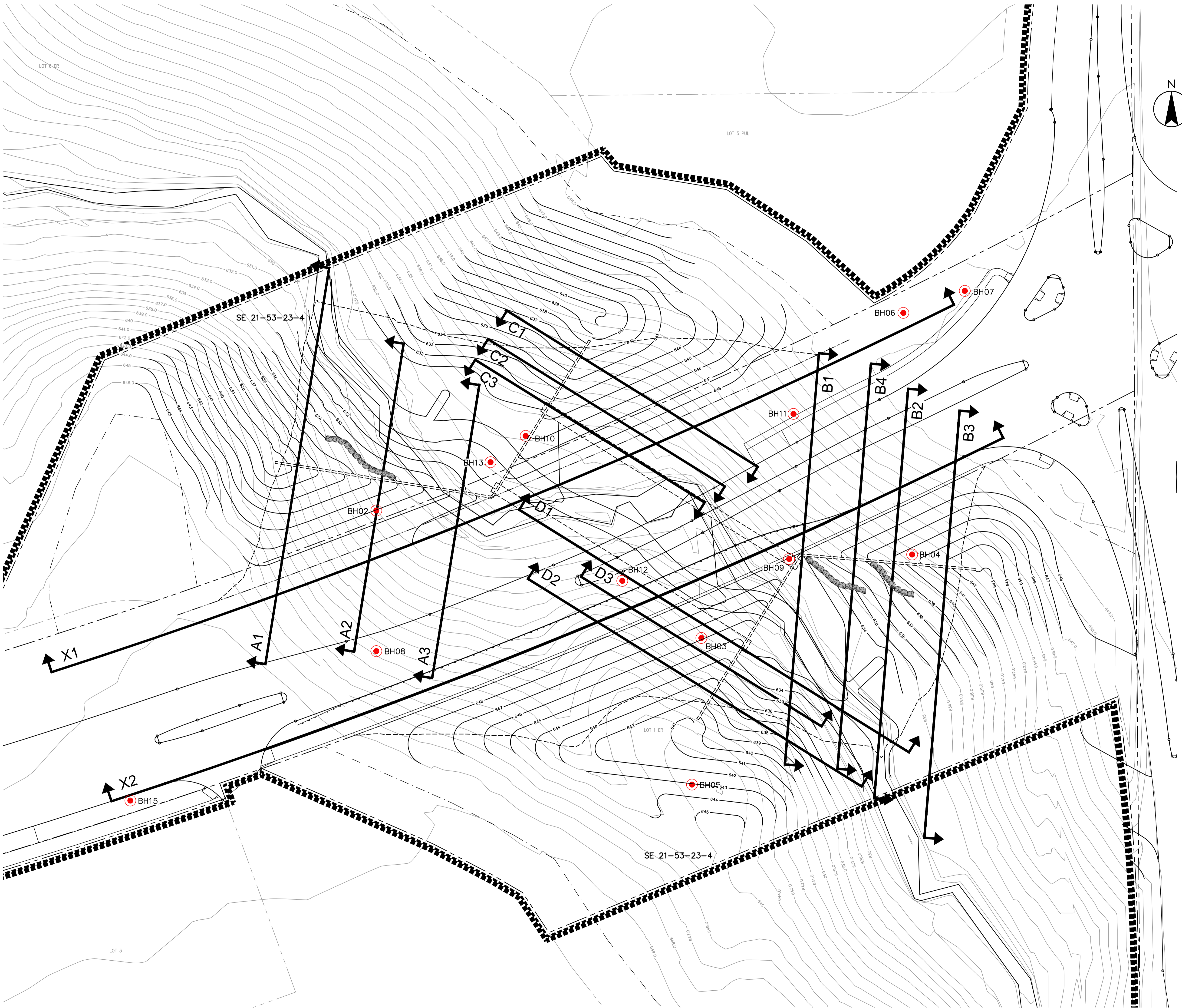

Stantec Consulting Ltd.
 10160 - 112 Street
 Edmonton AB Canada
 Tel. 780.917.7000
 www.stantec.com

Copyright Reserved
 The Contractor shall verify and be responsible for all dimensions. DO NOT scale the drawing - any error
 omissions shall be reported to Stantec without delay. The Copyrights to all designs and drawings are the
 property of Stantec. Reproduction or use for any purpose other than that authorized by Stantec is forbi

- Legend
- BOREHOLE LOCATION
 - LANDSCAPE FEATURE

Notes

-

Development Engineer, Sustainable Development			
Approvals			YY.MM
Revision	By	Appd.	YY.MM
Issued	By	Appd.	YY.MM
PROJECT MANAGER:	DESIGN:	RW	DRAWN:
		EC	

Permit-Seal

Client/Project
 AURUM INDUSTRIAL
 DEVELOPMENT PARTNERSHIP
 AURUM ROAD
 N. OF 127 AVENUE, W. OF 17 STREET
 EDMONTON, AB

Title
 PROPOSED GRADING
 AND SECTION PLAN

Project No. 123312651	Scale 1:400	
--------------------------	----------------	--

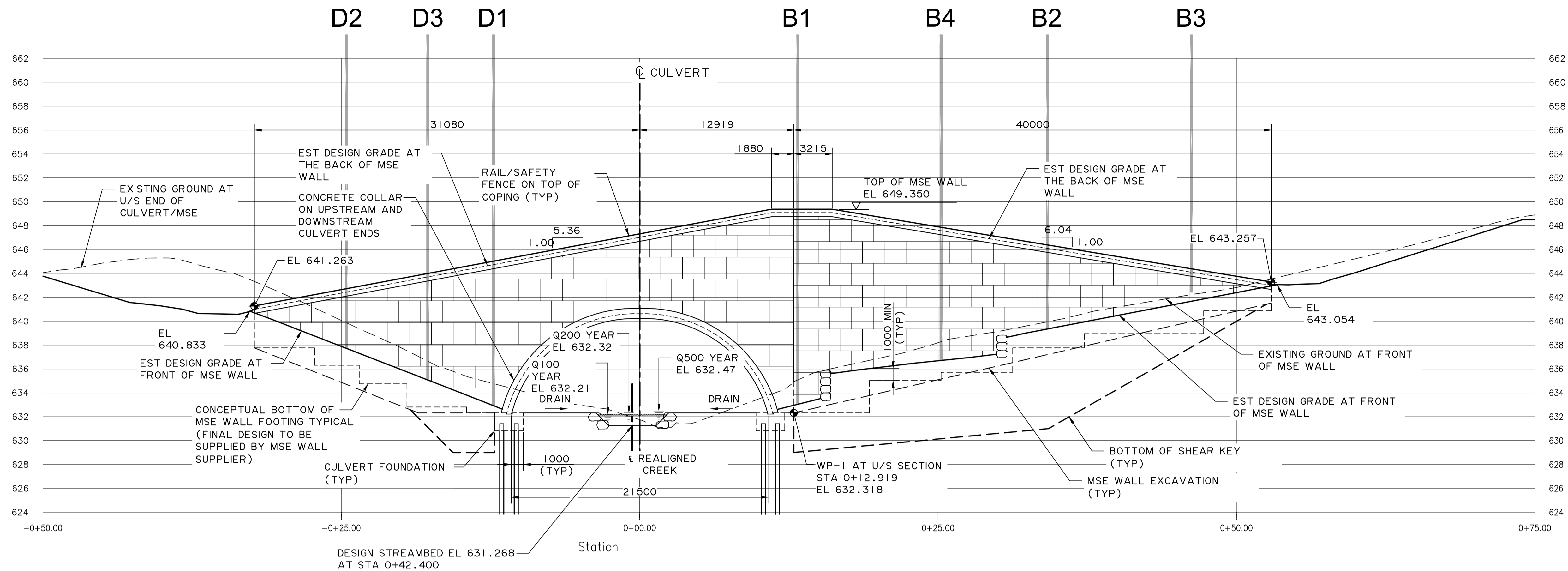

- NOTES:
- BOTTOM OF MSE WALL/FOUNDATION/FOOTING BELOW THE EXISTING GROUND IS STILL IN REVIEW.
 - HANDRAIL WILL BE UPDATED AFTER MSE WALL DESIGN IS FINALIZED.

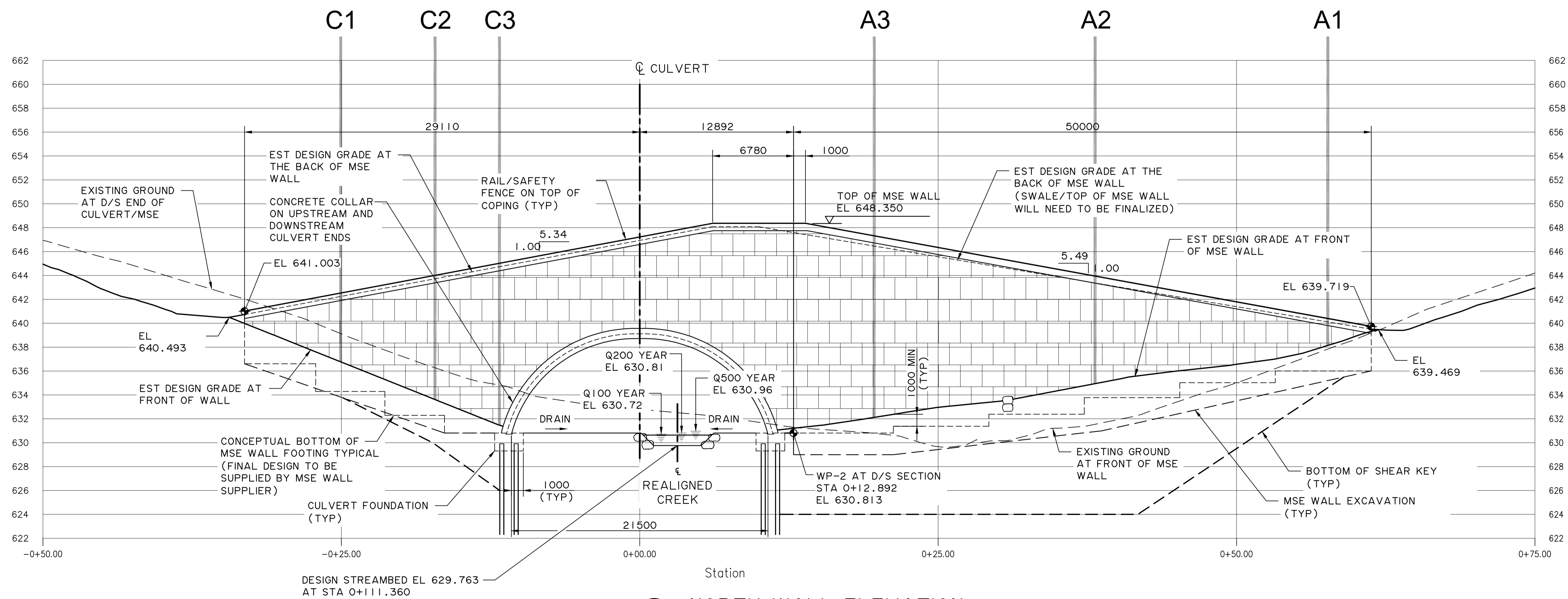

- NOTES:
- BOTTOM OF MSE WALL/FOUNDATION/FOOTING BELOW THE EXISTING GROUND IS STILL IN REVIEW.
 - HANDRAIL WILL BE UPDATED AFTER MSE WALL DESIGN IS FINALIZED.

Development Engineer, Sustainable Development			
Approvals			YY.MM
Revision	By	Appd.	YY.MM
Issued	By	Appd.	YY.MM
PROJECT MANAGER:	DESIGN:	RW	DRAWN: EC

Permit-Seal

PRELIMINARY
- NOT FOR CONSTRUCTION -

Client/Project
AURUM INDUSTRIAL
DEVELOPMENT PARTNERSHIP
AURUM ROAD
9 STREET NE TO 17 STREET NE
EDMONTON, AB

Title
AURUM ROAD
MSE WALL - SHEET 2

Project No. 1161104130 Scale 1:200



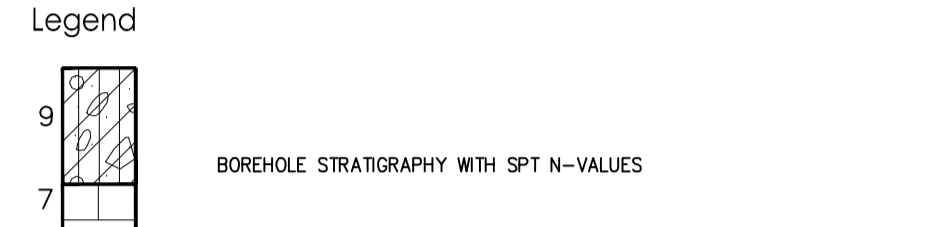

Notes

-



Development Engineer, Sustainable Development			
Approvals			YY.MM
Revision	By	Appr.	YY.MM
Issued	By	Appr.	YY.MM
PROJECT MANAGER	DESIGN	DRAWN	EC

Client/Project
AURUM INDUSTRIAL
DEVELOPMENT PARTNERSHIP
AURUM ROAD
N. OF 127 AVENUE, W. OF 17 STREET
EDMONTON, AB

Title
AURUM INDUSTRIAL
SECTIONS

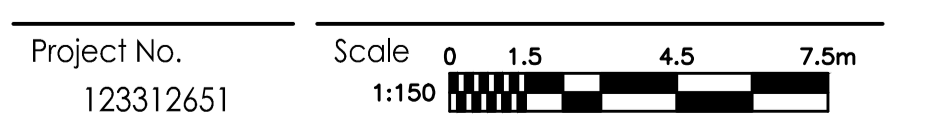

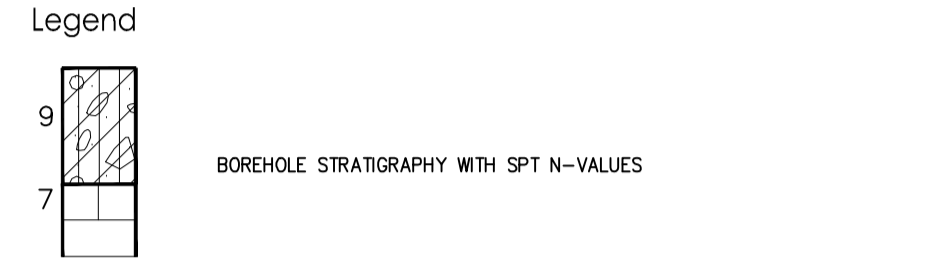

Notes

-



Development Engineer, Sustainable Development			
Approvals			YY.MM
Revision	By	Appd.	YY.MM
Issued	By	Appd.	YY.MM
PROJECT MANAGER	DESIGN	RW	DRAWN: EC

Permit-Seal

Client/Project
 AURUM INDUSTRIAL
 DEVELOPMENT PARTNERSHIP
 AURUM ROAD
 N. OF 127 AVENUE, W. OF 17 STREET
 EDMONTON, AB

Title
 AURUM INDUSTRIAL
 SECTIONS

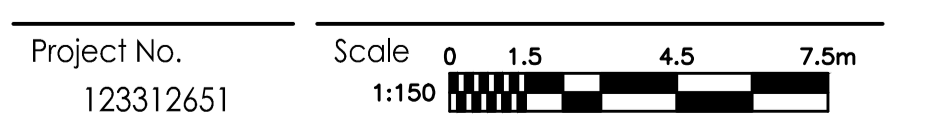
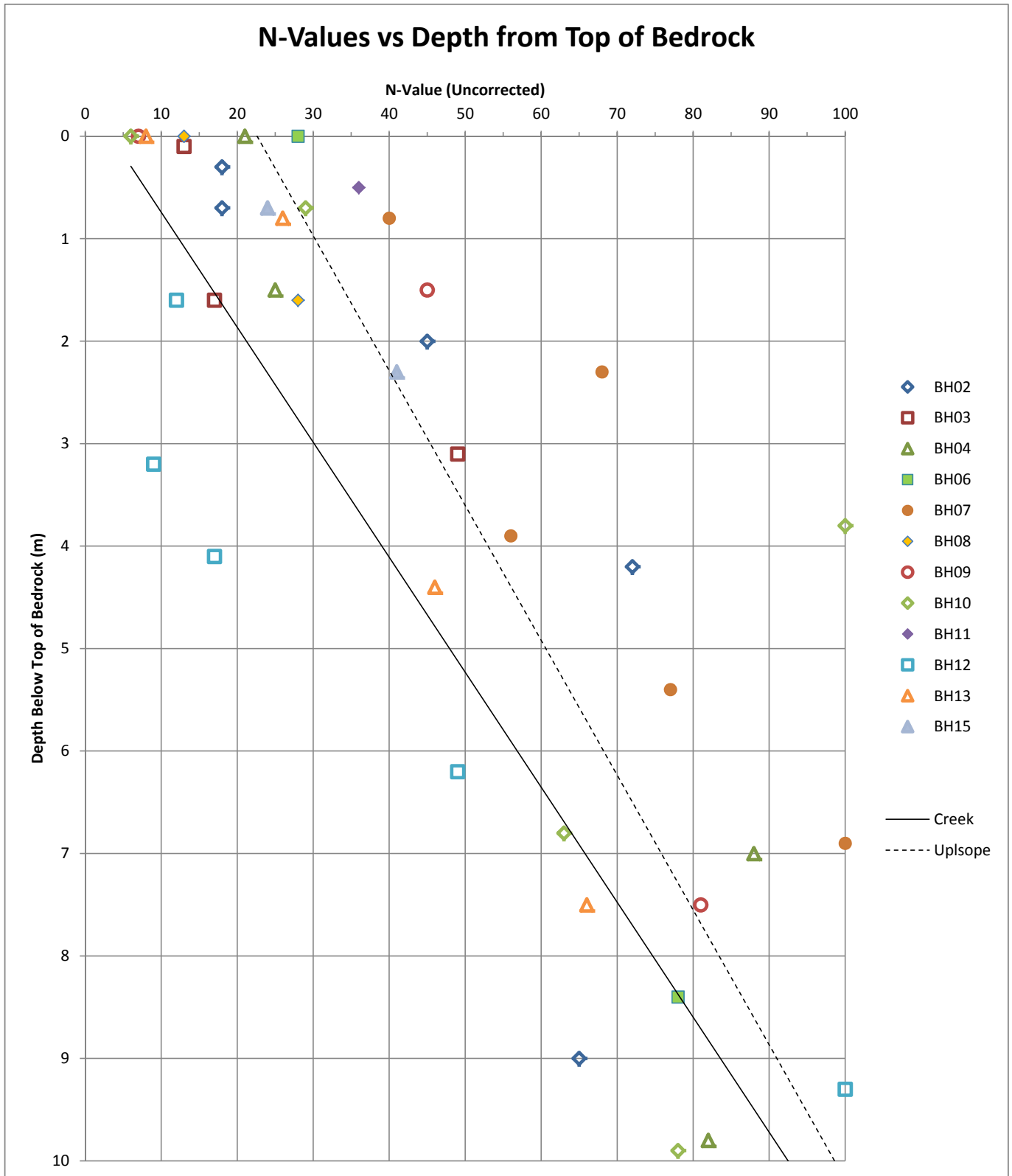

Figure 8



GEOTECHNICAL INVESTIGATION REPORT

February 24, 2017

Appendix C

Symbols & Terms and Borehole Records



SYMBOLS AND TERMS USED ON BOREHOLE AND TEST PIT RECORDS

SOIL DESCRIPTION

Terminology describing common soil genesis:

<i>Rootmat</i>	- vegetation, roots and moss with organic matter and topsoil typically forming a mattress at the ground surface
<i>Topsoil</i>	- mixture of soil and humus capable of supporting vegetative growth
<i>Peat</i>	- mixture of visible and invisible fragments of decayed organic matter
<i>Till</i>	- unstratified glacial deposit which may range from clay to boulders
<i>Fill</i>	- material below the surface identified as placed by humans (excluding buried services)

Terminology describing soil structure:

<i>Desiccated</i>	- having visible signs of weathering by oxidization of clay minerals, shrinkage cracks, etc.
<i>Fissured</i>	- having cracks, and hence a blocky structure
<i>Varved</i>	- composed of regular alternating layers of silt and clay
<i>Stratified</i>	- composed of alternating successions of different soil types, e.g. silt and sand
<i>Layer</i>	- > 75 mm in thickness
<i>Seam</i>	- 2 mm to 75 mm in thickness
<i>Parting</i>	- < 2 mm in thickness

Terminology describing soil types:

The classification of soil types are made on the basis of grain size and plasticity in accordance with the Unified Soil Classification System (USCS) (ASTM D 2487 or D 2488) which excludes particles larger than 75 mm. For particles larger than 75 mm, and for defining percent clay fraction in hydrometer results, definitions proposed by Canadian Foundation Engineering Manual, 4th Edition are used. The USCS provides a group symbol (e.g. SM) and group name (e.g. silty sand) for identification.

Terminology describing cobbles, boulders, and non-matrix materials (organic matter or debris):

Terminology describing materials outside the USCS, (e.g. particles larger than 75 mm, visible organic matter, and construction debris) is based upon the proportion of these materials present:

<i>Trace, or occasional</i>	Less than 10%
<i>Some</i>	10-20%
<i>Frequent</i>	> 20%

Terminology describing compactness of cohesionless soils:

The standard terminology to describe cohesionless soils includes compactness (formerly "relative density"), as determined by the Standard Penetration Test (SPT) N-Value - also known as N-Index. The SPT N-Value is described further on page 3. A relationship between compactness condition and N-Value is shown in the following table.

Compactness Condition	SPT N-Value
<i>Very Loose</i>	<4
<i>Loose</i>	4-10
<i>Compact</i>	10-30
<i>Dense</i>	30-50
<i>Very Dense</i>	>50

Terminology describing consistency of cohesive soils:

The standard terminology to describe cohesive soils includes the consistency, which is based on undrained shear strength as measured by *in situ* vane tests, penetrometer tests, or unconfined compression tests. Consistency may be crudely estimated from SPT N-Value based on the correlation shown in the following table (Terzaghi and Peck, 1967). The correlation to SPT N-Value is used with caution as it is only very approximate.

Consistency	Undrained Shear Strength		Approximate SPT N-Value
	kips/sq.ft.	kPa	
<i>Very Soft</i>	<0.25	<12.5	<2
<i>Soft</i>	0.25 - 0.5	12.5 - 25	2-4
<i>Firm</i>	0.5 - 1.0	25 - 50	4-8
<i>Stiff</i>	1.0 - 2.0	50 - 100	8-15
<i>Very Stiff</i>	2.0 - 4.0	100 - 200	15-30
<i>Hard</i>	>4.0	>200	>30

ROCK DESCRIPTION

Except where specified below, terminology for describing rock is as defined by the International Society for Rock Mechanics (ISRM) 2007 publication "The Complete ISRM Suggested Methods for Rock Characterization, Testing and Monitoring: 1974-2006"

Terminology describing rock quality:

RQD	Rock Mass Quality
0-25	Very Poor Quality
25-50	Poor Quality
50-75	Fair Quality
75-90	Good Quality
90-100	Excellent Quality

Alternate (Colloquial) Rock Mass Quality	
Very Severely Fractured	Crushed
Severely Fractured	Shattered or Very Blocky
Fractured	Blocky
Moderately Jointed	Sound
Intact	Very Sound

RQD (Rock Quality Designation) denotes the percentage of intact and sound rock retrieved from a borehole of any orientation. All pieces of intact and sound rock core equal to or greater than 100 mm (4 in.) long are summed and divided by the total length of the core run. RQD is determined in accordance with ASTM D6032.

SCR (Solid Core Recovery) denotes the percentage of solid core (cylindrical) retrieved from a borehole of any orientation. All pieces of solid (cylindrical) core are summed and divided by the total length of the core run (It excludes all portions of core pieces that are not fully cylindrical as well as crushed or rubble zones).

Fracture Index (FI) is defined as the number of naturally occurring fractures within a given length of core. The Fracture Index is reported as a simple count of natural occurring fractures.

Terminology describing rock with respect to discontinuity and bedding spacing:

Spacing (mm)	Discontinuities	Bedding
>6000	Extremely Wide	-
2000-6000	Very Wide	Very Thick
600-2000	Wide	Thick
200-600	Moderate	Medium
60-200	Close	Thin
20-60	Very Close	Very Thin
<20	Extremely Close	Laminated
<6	-	Thinly Laminated

Terminology describing rock strength:

Strength Classification	Grade	Unconfined Compressive Strength (MPa)
Extremely Weak	R0	<1
Very Weak	R1	1 – 5
Weak	R2	5 – 25
Medium Strong	R3	25 – 50
Strong	R4	50 – 100
Very Strong	R5	100 – 250
Extremely Strong	R6	>250

Terminology describing rock weathering:

Term	Symbol	Description
Fresh	W1	No visible signs of rock weathering. Slight discoloration along major discontinuities
Slightly	W2	Discoloration indicates weathering of rock on discontinuity surfaces. All the rock material may be discolored.
Moderately	W3	Less than half the rock is decomposed and/or disintegrated into soil.
Highly	W4	More than half the rock is decomposed and/or disintegrated into soil.
Completely	W5	All the rock material is decomposed and/or disintegrated into soil. The original mass structure is still largely intact.
Residual Soil	W6	All the rock converted to soil. Structure and fabric destroyed.

STRATA PLOT

Strata plots symbolize the soil or bedrock description. They are combinations of the following basic symbols. The dimensions within the strata symbols are not indicative of the particle size, layer thickness, etc.

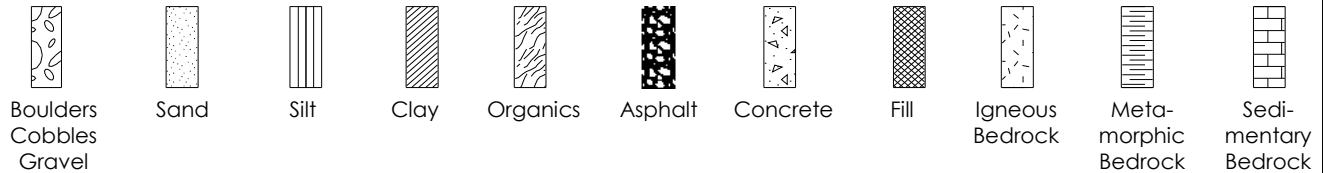

SAMPLE TYPE

SS	Split spoon sample (obtained by performing the Standard Penetration Test)
ST	Shelby tube or thin wall tube
DP	Direct-Push sample (small diameter tube sampler hydraulically advanced)
PS	Piston sample
BS	Bulk sample
HQ, NQ, BQ, etc.	Rock core samples obtained with the use of standard size diamond coring bits.

WATER LEVEL MEASUREMENT

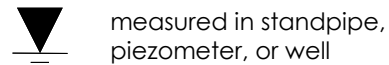

measured in standpipe, piezometer, or well



inferred

RECOVERY

For soil samples, the recovery is recorded as the length of the soil sample recovered. For rock core, recovery is defined as the total cumulative length of all core recovered in the core barrel divided by the length drilled and is recorded as a percentage on a per run basis.

N-VALUE

Numbers in this column are the field results of the Standard Penetration Test: the number of blows of a 140 pound (63.5 kg) hammer falling 30 inches (760 mm), required to drive a 2 inch (50.8 mm) O.D. split spoon sampler one foot (300 mm) into the soil. In accordance with ASTM D1586, the N-Value equals the sum of the number of blows (N) required to drive the sampler over the interval of 6 to 18 in. (150 to 450 mm). However, when a 24 in. (610 mm) sampler is used, the number of blows (N) required to drive the sampler over the interval of 12 to 24 in. (300 to 610 mm) may be reported if this value is lower. For split spoon samples where insufficient penetration was achieved and N-Values cannot be presented, the number of blows are reported over sampler penetration in millimetres (e.g. 50/75). Some design methods make use of N-values corrected for various factors such as overburden pressure, energy ratio, borehole diameter, etc. No corrections have been applied to the N-values presented on the log.

DYNAMIC CONE PENETRATION TEST (DCPT)

Dynamic cone penetration tests are performed using a standard 60 degree apex cone connected to 'A' size drill rods with the same standard fall height and weight as the Standard Penetration Test. The DCPT value is the number of blows of the hammer required to drive the cone one foot (300 mm) into the soil. The DCPT is used as a probe to assess soil variability.

OTHER TESTS

S	Sieve analysis
H	Hydrometer analysis
k	Laboratory permeability
γ	Unit weight
G_s	Specific gravity of soil particles
CD	Consolidated drained triaxial
CU	Consolidated undrained triaxial with pore pressure measurements
UU	Unconsolidated undrained triaxial
DS	Direct Shear
C	Consolidation
Q_u	Unconfined compression
I_p	Point Load Index (I_p on Borehole Record equals $I_p(50)$ in which the index is corrected to a reference diameter of 50 mm)

	Single packer permeability test; test interval from depth shown to bottom of borehole
	Double packer permeability test; test interval as indicated
	Falling head permeability test using casing
	Falling head permeability test using well point or piezometer



BH01

CLIENT Aurum Industrial Development Partnership Borehole Coordinates PROJECT No. 123312651
 PROJECT Aurum Road Creek Crossing 44499 E BH ELEVATION 645.8m
 LOCATION Aurum Road 5939576 N DATUM: 3TM 114
 BORING DATES (mm/dd/yyyy): 9/19/2016 WATER LEVEL m on 7.9 m on 9/19/2016

DEPTH(m)	ELEVATION(m)	SOIL DESCRIPTION	STRATA PLOT	SAMPLES				MONITOR WELL/ PIEZOMETER	Undrained Shear Strength (Cu) : (kPa) ▲ Cu based on Pocket Penetrometer : (kPa) ★ 50 100 150 200 Cu Scale (kPa) WATER CONTENT & ATTERBERG LIMITS W _P W W _L SPT (N), BLOWS/0.3m and RQD% ● 10 20 30 40 50 60 70 80 %MC or Blow Count Scale (% or N)								ELEVATION(m)		
				TYPE	NUMBER	RECOVERY mm or CORE %	N-VALUE or RQD %		10	20	30	40	50	60	70	80			
0	645.80	TOPSOIL (300 mm)																	645.80
	645.50	CLAY TILL (CI), silty, some sand, stiff, brown, occasional oxide staining, occasional rootlets to 1.3 m - Atterberg limit on bulk sample 1 - hydrometer test on Bulk 1 at 0.8 m [Gravel: 0%, Sand: 26%, Silt: 35%, Clay 39%]		BS 1															645
1				SS 2	220	17													645
				BS 3															644
2				SS 4	420	20													643
		- trace gravel below 3.2 m		BS 5															642
4	642.00	- low plastic below 3.8 m SAND, silty, compact, brown, poorly graded - occasional oxide staining at 3.8 m		SS 6	370	24													642
				BS 7															641
5		- becomes dense below 5.3 m		SS 8	330	34													640
				BS 9															639
7		- trace gravel at 6.9 m		SS 10	350	30													638
	638.30	CLAY TILL (CI), silty, some sand, trace gravel, brown		BS 11															638
8	637.90	- seepage inferred at 7.8 m		BS 12															638
	637.60	SAND, trace gravel, dense, brown, poorly graded		SS 13	300	36													637
				BS 14															636
10	635.90																		636
		*Water level from water seepage observation during drilling																	

STANTEC GEO 2016 123312651_AURUM_ROAD_BH_LOGS.GPJ MASTER1.GDT 2/23/17



BH01

CLIENT Aurum Industrial Development Partnership Borehole Coordinates PROJECT No. 123312651
 PROJECT Aurum Road Creek Crossing 44499 E BH ELEVATION 645.8m
 LOCATION Aurum Road 5939576 N DATUM: 3TM 114
 BORING DATES (mm/dd/yyyy): 9/19/2016 WATER LEVEL m on 7.9 m on 9/19/2016

DEPTH(m)	ELEVATION(m)	SOIL DESCRIPTION	STRATA PLOT	SAMPLES				MONITOR WELL/ PIEZOMETER	Undrained Shear Strength (Cu) : (kPa) ▲ Cu based on Pocket Penetrometer : (kPa) ★ 50 100 150 200 Cu Scale (kPa) WATER CONTENT & ATTERBERG LIMITS W _P W W _L SPT (N), BLOWS/0.3m and RQD% ● 10 20 30 40 50 60 70 80 %MC or Blow Count Scale (% or N)										ELEVATION(m)
				TYPE	NUMBER	RECOVERY mm or CORE %	N-VALUE or RQD %												
10	635.40	CLAY TILL (CI), silty, some sand, trace gravel, hard, grey, occasional coal fragments		SS	15	200	39												635
11		Borehole completed at 10.4 m Upon completion on September 19, 2016: - slough to 8.5 m - water at 7.9 m - bentonite seal from 8.5 m to 1.0 m - cuttings from 1.0 m to ground surface																	634
12		Bulk sample 1 obtained from 0.8 m to 3.0 m.																	633
13																			632
14																			631
15																			630
16																			629
17																			628
18																			627
19																			626
20																			

*Water level from water seepage observation during drilling



BH02

CLIENT Aurum Industrial Development Partnership Borehole Coordinates PROJECT No. 123312651
 PROJECT Aurum Road Creek Crossing 44844 E BH ELEVATION 633.1m
 LOCATION Aurum Road 5939603 N DATUM: 3TM114
 BORING DATES (mm/dd/yyyy): 9/8/2016 WATER LEVEL 3.35 m on 3.35 m on 11/23/2016

DEPTH(m)	ELEVATION(m)	SOIL DESCRIPTION	STRATA PLOT	SAMPLES				MONITOR WELL/ PIEZOMETER	Undrained Shear Strength (Cu) : (kPa) ▲ Cu based on Pocket Penetrometer : (kPa) ★		ELEVATION(m)
				TYPE	NUMBER	RECOVERY mm or CORE %	N-VALUE or RQD %		50	100	
0	633.10	CLAY mixed with ORGANICS, some sand, trace gravel, dark brown, occasional rootlets									633
1	632.60	CLAY colluvium (Cl), silty, some sand, trace gravel, firm, brown, occasional oxide staining, occasional coal fragments, occasional rootlets to 1.0 m - trace bedrock fragments at 0.8 m to 1.5 m		BS 1							632
				SS 2	340	7					
				BS 3							
				BS 4							
2		- increased sand content below 2.0 m									
	630.80	- occasional rootlets at 2.0 m		SS 5a	260	7					631
		- becomes dark brown below		SS 5b	300						
		- frequent organics at 2.6 m		BS 6							
	629.75	- occasional rootlets and 20 mm coal seam at 3.3 m		SS 7	380	6					630
				BS 8							
				SS 9	430	7					
		- 30 mm sand with occasional coal fragments at 4.2 m		BS 10							629
				SS 11	580	6					
		- occasional coal with trace bedrock fragments at 4.8 m		BS 12							
	627.50	- seepage inferred at 5.3 m		ST 13	300						628
6		Brown SANDSTONE, extremely weak, highly weathered		SS 14	230	18					627
		- cemented sandstone fragments at 5.9 m		SS 15	200	18					
		- completely weathered bluish-grey bentonitic sandstone below 6.3 m									
		- sieve analysis on SS15 at 6.4 m [1% gravel; 51% sand; 22% silt; 26% clay]		BS 16							626
		- shale seams at 7.3 m									
		- switch to rotary coring at 7.6 m		SS 17	430	45					
		- becomes light greyish brown below 8.1 m		RC 1	61	31					625
		- stratified high plastic clay beds below 8.3 m									
				RC 2	98	65					624
		- 100 mm very weak strength rock at 8.9 m									
		- highly weathered below 9.8 m									
		- brown shale interbedded with blue-grey sandstone at 9.8 m									
10											

*Water level from water seepage observation during drilling ∇
 **Groundwater level measured on date indicated. ▼

STANTEC GEO 2016 123312651_AURUM_ROAD_BH_LOGS.GPJ MASTER1.GDT 2/23/17



BH02

CLIENT Aurum Industrial Development Partnership Borehole Coordinates PROJECT No. 123312651
 PROJECT Aurum Road Creek Crossing 44844 E BH ELEVATION 633.1m
 LOCATION Aurum Road 5939603 N DATUM: 3TM 114
 BORING DATES (mm/dd/yyyy): 9/8/2016 WATER LEVEL 3.35 m on 3.35 m on 11/23/2016

DEPTH(m)	ELEVATION(m)	SOIL DESCRIPTION	STRATA PLOT	SAMPLES				MONITOR WELL/ PIEZOMETER	Undrained Shear Strength (Cu) : (kPa) ▲ Cu based on Pocket Penetrometer : (kPa) ★		ELEVATION(m)
				TYPE	NUMBER	RECOVERY mm or CORE %	N-VALUE or RQD %		50	100	
10		Brown CLAY SHALE stratified with grey SANDSTONE, extremely weak, highly weathered - 120 mm of very weak strength bedrock at 10.2 m, thinly laminated horizontal bedding - thinly laminated blue-grey bentonitic sandstone seams at 11.5 m - 40 mm coal seam at 14.5 m		SS	18	390	72				623
			RC	3	84	39					622
			RC	4	99	93					621
			RC	5	100	92					620
			SS	19	500	65					619
15	618.00	Borehole completed at 15.1 m Upon completion on September 8, 2016: - slough to 14.6 m - water at 2.3 m after coring - backfilled with sand from 11.6 m to 14.6 m - bentonite seal from 5.5 m to 11.6 m - cuttings from 5.5 m to ground surface Water level on September 9, 2016 at 3.35 m. Water level on September 10, 2016 at 3.36 m. Water level on September 12, 2016 at 3.52 m. Water level on September 13, 2016 at 3.53 m. Water level on September 17, 2016 at 3.55 m. Water level on September 19, 2016 at 3.52 m. Water level on October 4, 2016 at 3.49 m. Water level on November 23, 2016 at 3.35 m.									618
16											617
17											616
18											615
19											614
20											

STANTEC GEO 2016 123312651_AURUM_ROAD_BH_LOGS.GPJ MASTER1.GDT 2/23/17

*Water level from water seepage observation during drilling ∇
 **Groundwater level measured on date indicated. ▼



BH03

CLIENT Aurum Industrial Development Partnership Borehole Coordinates PROJECT No. 123312651
 PROJECT Aurum Road Creek Crossing 44918 E BH ELEVATION 635.0m
 LOCATION Aurum Road 5939574 N DATUM: 3TM114
 BORING DATES (mm/dd/yyyy): 9/7/2016 WATER LEVEL N/A

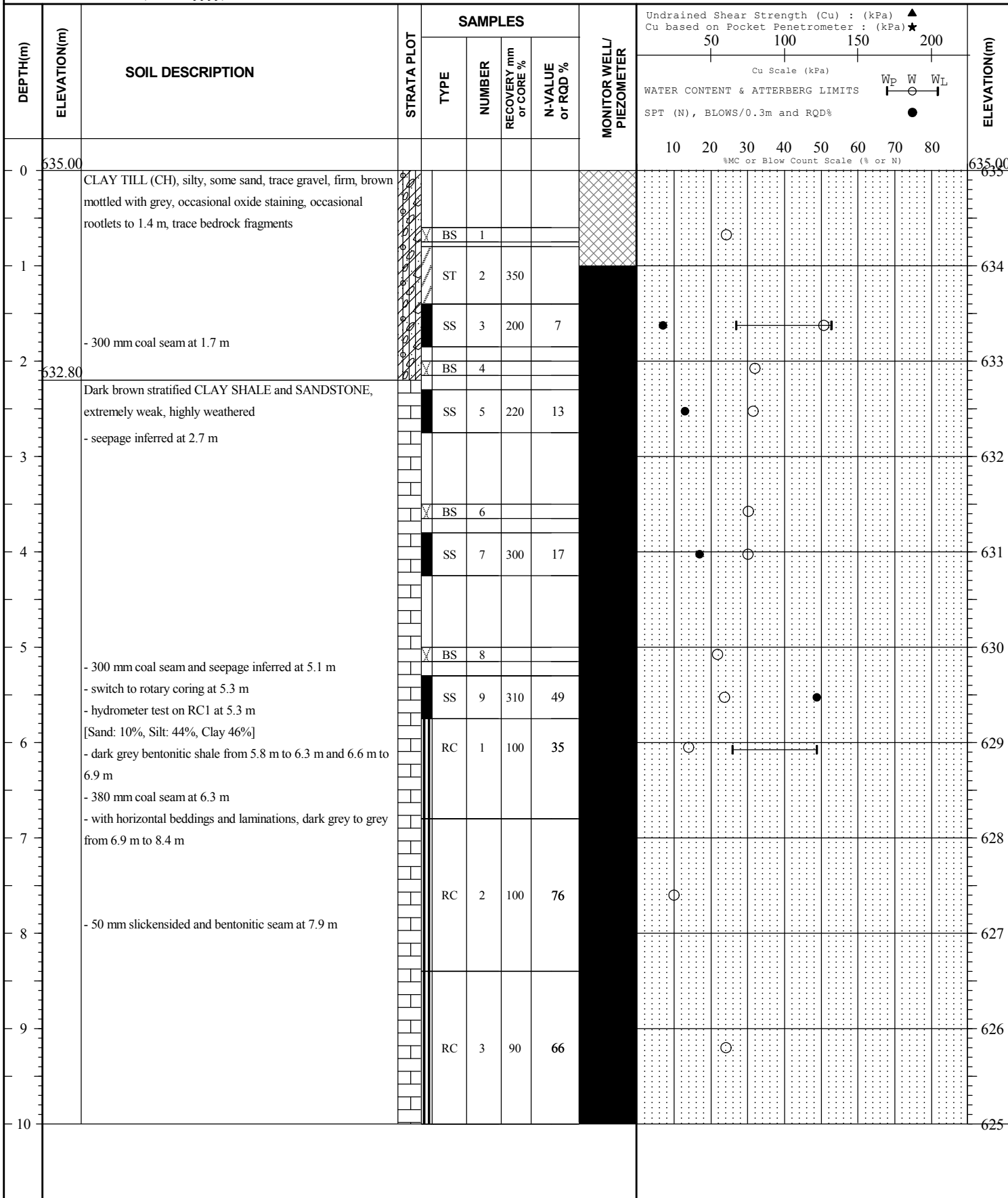

STANTEC GEO 2016 123312651_AURUM_ROAD_BH_LOGS.GPJ MASTER1.GDT 2/23/17



BH03

CLIENT Aurum Industrial Development Partnership Borehole Coordinates PROJECT No. 123312651
 PROJECT Aurum Road Creek Crossing 44918 E BH ELEVATION 635.0m
 LOCATION Aurum Road 5939574 N DATUM: 3TM114
 BORING DATES (mm/dd/yyyy): 9/7/2016 WATER LEVEL N/A

DEPTH(m)	ELEVATION(m)	SOIL DESCRIPTION	STRATA PLOT	SAMPLES				MONITOR WELL/ PIEZOMETER	Undrained Shear Strength (Cu) : (kPa) ▲ Cu based on Pocket Penetrometer : (kPa) ★		ELEVATION(m)
				TYPE	NUMBER	RECOVERY mm or CORE %	N-VALUE or RQD %		50	100	
10		Grey stratified SANDSTONE and CLAY SHALE, extremely weak, highly weathered		RC	4	93	68				625
11											624
12		- 50 mm thick dark grey bentonite seam at 11.9 m - 150 mm thick brown mudstone at 12.2 m - interbedded bentonitic sandstone below 12.4 m		RC	5	95	75				623
13											622
14		- grey clay shale below 14.4 m		RC	6	100	89				621
15	619.90			SS	10	510	85				620
16		Borehole completed at 15.1 m Upon completion on September 7, 2016: - slough to 14.9 m - backfilled with bentonite from 1.0 m to 14.9 m - bentonite seal from 1.0 m to ground surface									619
17											618
18											617
19											616
20											615

STANTEC GEO 2016 123312651_AURUM_ROAD_BH_LOGS.GPJ MASTER1.GDT 2/23/17



BH04

CLIENT Aurum Industrial Development Partnership Borehole Coordinates PROJECT No. 123312651
 PROJECT Aurum Road Creek Crossing 44966 E BH ELEVATION 640.2m
 LOCATION Aurum Road 5939593 N DATUM: 3TM 114
 BORING DATES (mm/dd/yyyy): 9/15/2016 WATER LEVEL 8.43 m on 8.43m on 11/23/2016

DEPTH(m)	ELEVATION(m)	SOIL DESCRIPTION	STRATA PLOT	SAMPLES				MONITOR WELL/ PIEZOMETER	Undrained Shear Strength (Cu) : (kPa) ▲ Cu based on Pocket Penetrometer : (kPa) ★		ELEVATION(m)	
				TYPE	NUMBER	RECOVERY mm or CORE %	N-VALUE or RQD %		50	100		150
0	640.20	SAND (SP), silty, trace gravel, compact, light brown, poorly graded, fine to medium grained	[Pattern]	BS	1						640	
1				BS	2							639
2				SS	3	230	14					638
3				BS	4							637
4		- becomes reddish brown with increased clay content below 3.7 m										
5	635.60	Brown CLAY SHALE stratified with SANDSTONE, extremely weak, highly weathered - 300 mm coal layer at 5.2 m - 400 mm of frequent coal intermixed with bedrock and becomes dark brown to black at 5.6 m - frequent oxide staining from 6.1 m to 6.6 m - cobble plugged RC1 resulting in no recovery - switch to rotary coring at 6.1 m	[Pattern]	SS	7	180	21				635	
6				BS	8							634
7				SS	9	400	25					634
8	634.30			RC	1	0	0				633	
9				RC	2	95	69				632	
10	631.77	- becomes lighter grey below 8.5 m		RC	3	98	81				631	

*Water level from water seepage observation during drilling ∇
 **Groundwater level measured on date indicated. ▼

STANTEC GEO 2016 123312651_AURUM_ROAD_BH_LOGS.GPJ MASTER1.GDT 2/23/17



BH04

CLIENT Aurum Industrial Development Partnership Borehole Coordinates PROJECT No. 123312651
 PROJECT Aurum Road Creek Crossing 44966 E BH ELEVATION 640.2m
 LOCATION Aurum Road 5939593 N DATUM: 3TM 114
 BORING DATES (mm/dd/yyyy): 9/15/2016 WATER LEVEL 8.43 m on 8.43m on 11/23/2016

DEPTH(m)	ELEVATION(m)	SOIL DESCRIPTION	STRATA PLOT	SAMPLES				MONITOR WELL/ PIEZOMETER	Undrained Shear Strength (Cu) : (kPa) ▲ Cu based on Pocket Penetrometer : (kPa) ★		ELEVATION(m)
				TYPE	NUMBER	RECOVERY mm or CORE %	N-VALUE or RQD %		50	100	
10	630	Grey CLAY SHALE stratified with SANDSTONE, extremely weak, highly weathered									
11	629	- 40 mm of weak strength bedrock at 10.7 m		RC	4	97	61				
12	628	- 20 mm coal seam at 11.1 m - 100 mm of weak strength rock at 11.2 m - 150 mm coal seam at 11.3 m - 200 mm coal seam at 11.4 m - hydrometer test on RC5 at 11.6 m [Sand: 38%, Silt: 33%, Clay 29%] - interbedded grey bentonitic sandstone below 12.1 m		SS	10	450	88				
13	627	- 150 mm of completely weathered bluish-grey sandstone at 12.6 m - 50 mm thick bentonite seam at 12.75 m		RC	5	100	63				
14	626	- 80 mm of weak strength bedrock at 12.8 m - becomes highly to completely weathered bluish-grey sandstone stratified with brown clay shale, thinly laminated below 12.8 m		RC	6	84	44				
15	625.30	- 25 mm bentonite seam at 13.5 m - 25 mm bentonite seam at 14.1 m		SS	11	390	82				
15	625	Borehole completed at 14.9 m									
16	624	Upon completion on September 15, 2016: - slough to 13.4 m - water at 5.9 m after coring - backfilled with sand from 10.4 m to 13.4 m - bentonite seal from 6.1 m to 10.4 m - cuttings from 6.1 m to ground surface									
17	623	Water level on September 16, 2016 at 8.51 m. Water level on September 17, 2016 at 8.46 m. Water level on September 19, 2016 at 8.53 m. Water level on October 4, 2016 at 8.47 m. Water level on November 23, 2016 at 8.43 m.									
18	622										
19	621										
20											

STANTEC GEO 2016 123312651_AURUM_ROAD_BH_LOGS.GPJ MASTER1.GDT 2/23/17

*Water level from water seepage observation during drilling ∇
 **Groundwater level measured on date indicated. ▼



BH05

CLIENT Aurum Industrial Development Partnership Borehole Coordinates PROJECT No. 123312651
 PROJECT Aurum Road Creek Crossing 44916 E BH ELEVATION 644.9m
 LOCATION Aurum Road 5939541 N DATUM: 3TM114
 BORING DATES (mm/dd/yyyy): 9/9/2016 WATER LEVEL 6.64 m on 6.64 m on 11/23/2016

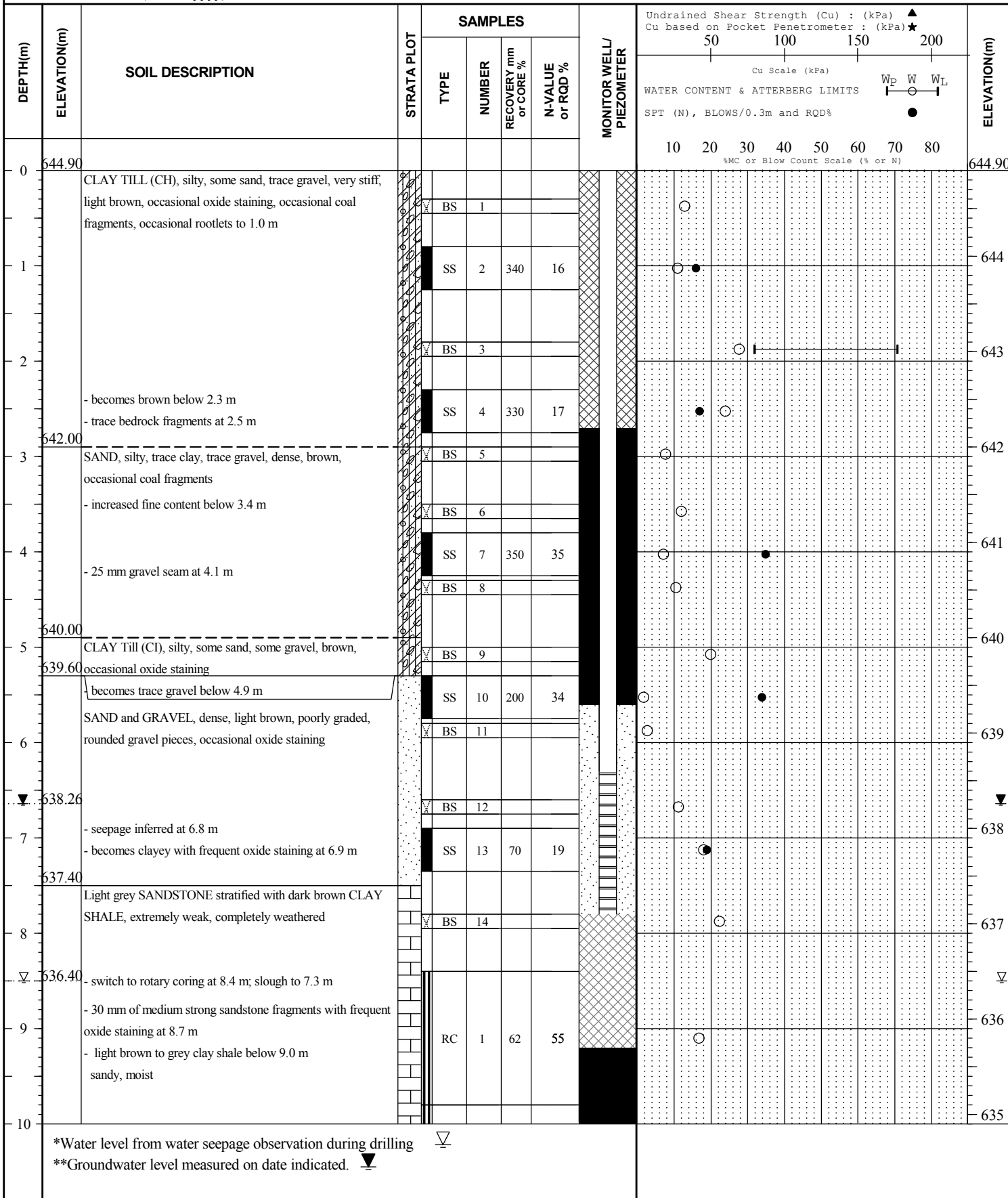

STANTEC GEO 2016 123312651_AURUM_ROAD_BH_LOGS.GPJ MASTER1.GDT 2/23/17



BH05

CLIENT Aurum Industrial Development Partnership Borehole Coordinates PROJECT No. 123312651
 PROJECT Aurum Road Creek Crossing 44916 E BH ELEVATION 644.9m
 LOCATION Aurum Road 5939541 N DATUM: 3TM 114
 BORING DATES (mm/dd/yyyy): 9/9/2016 WATER LEVEL 6.64 m on 6.64 m on 11/23/2016

DEPTH(m)	ELEVATION(m)	SOIL DESCRIPTION	STRATA PLOT	SAMPLES				MONITOR WELLS/ PIEZOMETER	Undrained Shear Strength (Cu) : (kPa) ▲ Cu based on Pocket Penetrometer : (kPa) ★		ELEVATION(m)
				TYPE	NUMBER	RECOVERY mm or CORE %	N-VALUE or RQD %		50	100	
10		Dark grey CLAY SHALE stratified with SANDSTONE, extremely weak, highly weathered (CL/CH)		RC	2	100	91				634
11											
12		- 190 mm coal seam at 11.7 m - becomes dark grey to black below 11.9 m - soil like from 11.9 m to 12.4 m - becomes dark brown with light grey horizontal bedding below 12.4 m		RC	3	95	53				633
13		- 100 mm weak strength bedrock									632
14				RC	4	100	92				631
15	630.50	Borehole completed at 14.4 m Upon completion on September 10, 2016: - slough to 14.6 m - water at 8.5 m after coring - backfilled with sand from 5.6 m to 7.8 m - bentonite seal from 9.2 m to 12.2 m and from 2.7 m to 5.6 m - cuttings from 7.8 m to 9.2 m and from 2.7 m to ground surface Water level on September 12, 2016 at 6.64 m. Water level on September 13, 2016 at 6.67 m. Water level on September 17, 2016 at 6.66 m. Water level on September 19, 2016 at 6.68 m. Water level on October 4, 2016 at 7.72 m. Water level on November 23, 2016 at 6.64 m.									630
16											629
17											628
18											627
19											626
20											625

*Water level from water seepage observation during drilling ∇
 **Groundwater level measured on date indicated. ▼

STANTEC GEO 2016 123312651_AURUM_ROAD_BH_LOGS.GPJ MASTER1.GDT 2/23/17



BH06

CLIENT Aurum Industrial Development Partnership Borehole Coordinates PROJECT No. 123312651
 PROJECT Aurum Road Creek Crossing 44964 E BH ELEVATION 648.7m
 LOCATION Aurum Road 5939648 N DATUM: 3TM 114
 BORING DATES (mm/dd/yyyy): 9/16/2016 WATER LEVEL m on Dry on 11/23/2016

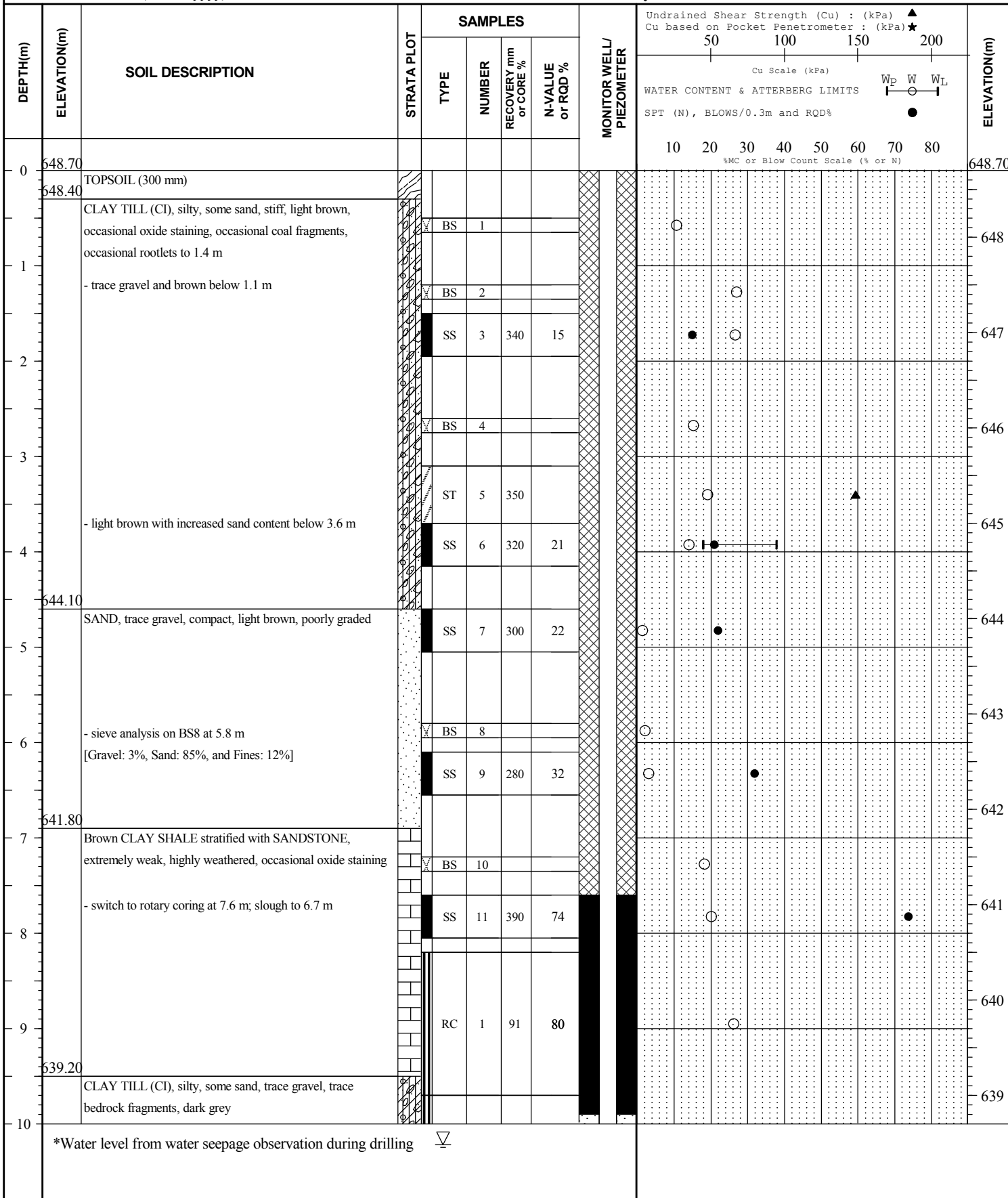

STANTEC GEO 2016 123312651_AURUM_ROAD_BH_LOGS.GPJ MASTER1.GDT 2/23/17



BH06

CLIENT Aurum Industrial Development Partnership Borehole Coordinates PROJECT No. 123312651
 PROJECT Aurum Road Creek Crossing 44964 E BH ELEVATION 648.7m
 LOCATION Aurum Road 5939648 N DATUM: 3TM 114
 BORING DATES (mm/dd/yyyy): 9/16/2016 WATER LEVEL m on Dry on 11/23/2016

DEPTH(m)	ELEVATION(m)	SOIL DESCRIPTION	STRATA PLOT	SAMPLES				MONITOR WELL/ PIEZOMETER	Undrained Shear Strength (Cu) : (kPa) ▲ Cu based on Pocket Penetrometer : (kPa) ★		ELEVATION(m)
				TYPE	NUMBER	RECOVERY mm or CORE %	N-VALUE or RQD %		50	100	
10	637.70	CLAY TILL (CI), silty, some sand, trace gravel, trace bedrock fragments, dark grey		RC	2	39					638
11		SAND, silty, clayey, trace gravel, trace bedrock fragments, brown - switch to solid stem at 11.3 m		BS	12						637
12	636.50	Dark brown CLAY SHALE stratified with SANDSTONE, extremely weak, highly weathered - 30 mm coal seam at 12.2 m		SS	13	210	28				636
13		- 400 mm coal seam, dark brown to black bedrock intermixed with coal to 13.3 m		BS	14						635
14	635.00	- switch to rotary coring									635
15		- grey below 14.5 m		RC	3	83	83				634
16		- very weak bedrock fragments at 16.0 m		RC	4	100	80				633
17		- 80 mm of very weak bedrock at 17.2 m		RC	5	93	39				632
18		- becomes brown below 17.5 m - hydrometer test on RC5 at 17.5 m [Sand 14%, Silt: 43%, Clay 43%] - 300 mm coal seam at 17.8 m		RC	6	90	80				631
19		- 280 mm coal seam at 18.5 m - grey below 18.8 m									630
20		- 240 mm of bluish-grey completely weathered sandstone below 19.5 m									629
*Water level from water seepage observation during drilling								▽			

STANTEC GEO 2016 123312651_AURUM_ROAD_BH_LOGS.GPJ MASTER1.GDT 2/23/17



BH06

CLIENT Aurum Industrial Development Partnership Borehole Coordinates PROJECT No. 123312651
 PROJECT Aurum Road Creek Crossing 44964 E BH ELEVATION 648.7m
 LOCATION Aurum Road 5939648 N DATUM: 3TM 114
 BORING DATES (mm/dd/yyyy): 9/16/2016 WATER LEVEL m on Dry on 11/23/2016

DEPTH(m)	ELEVATION(m)	SOIL DESCRIPTION	STRATA PLOT	SAMPLES				MONITOR WELLS/ PIEZOMETER	Undrained Shear Strength (Cu) : (kPa) ▲ Cu based on Pocket Penetrometer : (kPa) ★		ELEVATION(m)
				TYPE	NUMBER	RECOVERY mm or CORE %	N-VALUE or RQD %		50	100	
20		- 60 mm of medium strong bedrock - 160 mm of very weak bedrock Grey SANDSTONE stratified with CLAY SHALE, extremely weak, highly weathered		SS	15	530	78				628
21		- 50 mm of medium strong bedrock - 500 mm of bluish-grey completely weathered bentonitic sandstone with dark grey clay shale horizontal bedding at 20.6 m		RC	7	82	82				627
22		- highly weathered grey shale below 21.1 m - hydrometer test on RC7 at 21.7 m [Sand 41%, Silt: 33%, Clay 26%] - becomes light brown to 22.5 m		RC	8	100	62				626
23		thinly laminated and very weak below 23.1 m - 30 mm of medium strong bedrock									625
24		- thin to very thin laminations below 23.6 m - 80 mm of very weak bedrock at 23.6 m - 180 mm of weak bedrock		RC	9	100	91				624
25	623.20			SS	16	450	28/51				623
26		Borehole completed at 25.5 m Upon completion on September 17, 2016: - slough to 21.1 m - water at 13.7 m after coring - backfilled with sand from 9.9 m to 12.0 m - bentonite seal from 12.0 m to 13.7 m and from 7.6 m to 9.9 m - cuttings from 13.7 m to 21.1 m and from 7.6 m to ground surface Dry on September 19, 2016. Dry on October 4, 2016. Dry on November 23, 2016.									622
27											621
28											620
29											619
30											

STANTEC GEO 2016 123312651_AURUM_ROAD_BH_LOGS.GPJ MASTER1.GDT 2/23/17



BH07

CLIENT Aurum Industrial Development Partnership Borehole Coordinates PROJECT No. 123312651
 PROJECT Aurum Road Creek Crossing 44978 E BH ELEVATION 648.9m
 LOCATION Aurum Road 5939653 N DATUM: 3TM 114
 BORING DATES (mm/dd/yyyy): 9/17/2016 WATER LEVEL 12.44 m on 12.44 m on 11/23/2016

DEPTH(m)	ELEVATION(m)	SOIL DESCRIPTION	STRATA PLOT	SAMPLES				MONITOR WELL/ PIEZOMETER	Undrained Shear Strength (Cu) : (kPa) ▲ Cu based on Pocket Penetrometer : (kPa) ★		ELEVATION(m)
				TYPE	NUMBER	RECOVERY mm or CORE %	N-VALUE or RQD %		50	100	
0	648.90	TOPSOIL (300 mm)									648.90
0.6	648.60	CLAY TILL (CI), silty, some sand, very stiff, brown, occasional oxides, occasional rootlets to 1.0 m - becomes grey and brown with trace gravel below 0.8 m		BS 1							648
1.5		- becomes light brown below 1.5 m		BS 2							647
2.2		- becomes brown below 2.2 m		SS 3	400	22					646
3.1		- occasional coal fragments at 3.1 m		BS 4							645
3.8		- 100 mm sand seam at 3.8 m		SS 5	500	20					644
4.3	644.30	SAND, compact, light brown, poorly graded		BS 6							644
5.4		- trace gravel below 5.4 m		SS 7	160	19					643
5.8		- frequent oxide staining at 5.8 m		BS 8							642
6.2	642.80	Brown SANDSTONE stratified with CLAY SHALE, extremely weak, highly weathered, very thin laminations to laminated		SS 9	300	40					641
6.2		- frequent oxide staining at 6.2 m		BS 10							640
6.9		- 1.0 m coal layer at 6.9 m		BS 11							641
7.2				SS 12	220	46					640
8.1	640.50	CLAY TILL (CI), silty, some sand, trace gravel, brown, occasional oxides, occasional coal fragments		BS 13							639
8.9		- 400 mm dense silty, clayey, sand seam with occasional oxide staining at 9.2 m		SS 14	100	48					639
9.2	639.30	SAND (SF), silty, compact, brown, poorly graded									639

*Water level from water seepage observation during drilling ∇
 **Groundwater level measured on date indicated. ▼

STANTEC GEO 2016 123312651_AURUM_ROAD_BH_LOGS.GPJ MASTER1.GDT 2/23/17



BH07

CLIENT Aurum Industrial Development Partnership Borehole Coordinates PROJECT No. 123312651
 PROJECT Aurum Road Creek Crossing 44978 E BH ELEVATION 648.9m
 LOCATION Aurum Road 5939653 N DATUM: 3TM 114
 BORING DATES (mm/dd/yyyy): 9/17/2016 WATER LEVEL 12.44 m on 12.44 m on 11/23/2016

DEPTH(m)	ELEVATION(m)	SOIL DESCRIPTION	STRATA PLOT	SAMPLES				MONITOR WELL/ PIEZOMETER	Undrained Shear Strength (Cu) : (kPa) ▲ Cu based on Pocket Penetrometer : (kPa) ★ 50 100 150 200 Cu Scale (kPa) WATER CONTENT & ATTERBERG LIMITS W _P W W _L SPT (N), BLOWS/0.3m and RQD% ● 10 20 30 40 50 60 70 80 %MC or Blow Count Scale (% or N)								ELEVATION(m)				
				TYPE	NUMBER	RECOVERY mm or CORE %	N-VALUE or RQD %														
10		SAND (SF), silty, compact, brown, poorly graded		BS	15																
		- gravelly below 10.7 m																			
11		- trace grey and dark brown bedrock fragments below 11.0 m		SS	16	450	12														638
	637.50	- sieve analysis on BS17 at 11.2 m [Gravel: 26%, Sand 58%, Fines 16%]		BS	17																
12		Brown SANDSTONE stratified with CLAY SHALE, extremely weak, highly weathered		BS	18																637
	636.46	- 250 mm coal seam at 12.6 m		SS	19	490	40														636
13		- grey below 13.0 m																			
	635.20	- seepage inferred at 13.7 m		BS	20																635
14				SS	21	0	68														
15				BS	22																634
16				SS	23	250	56														633
17				BS	24																632
18				SS	25	170	77														
				BS	26																631
		- 450 mm coal seam		SS	27	200	50 (127 mm)														
	630.10																				630
19		Borehole completed at 18.8 m Upon completion on September 17, 2016: - no slough with water at 13.7 m - backfilled with sand from 12.2 m to 15.0 m - bentonite seal from 15.0 m to 15.7 m, from 11.3 m																			
20																					629

*Water level from water seepage observation during drilling ∇
 **Groundwater level measured on date indicated. ▼

STANTEC GEO 2016 123312651_AURUM_ROAD_BH_LOGS.GPJ MASTER1.GDT 2/23/17



BH07

CLIENT Aurum Industrial Development Partnership Borehole Coordinates PROJECT No. 123312651
 PROJECT Aurum Road Creek Crossing 44978 E BH ELEVATION 648.9m
 LOCATION Aurum Road 5939653 N DATUM: 3TM 114
 BORING DATES (mm/dd/yyyy): 9/17/2016 WATER LEVEL 12.44 m on 12.44 m on 11/23/2016

DEPTH(m)	ELEVATION(m)	SOIL DESCRIPTION	STRATA PLOT	SAMPLES				MONITOR WELL/ PIEZOMETER	Undrained Shear Strength (Cu) : (kPa) ▲ Cu based on Pocket Penetrometer : (kPa) ★		ELEVATION(m)
				TYPE	NUMBER	RECOVERY mm or CORE %	N-VALUE or RQD %		50	100	
20		to 12.2 m, and from 0.3 m to 0.8 m - cuttings from 15.3 m to 18.8 m, from 0.8 m to 11.3 m, and from 0.3 m to ground surface Water level on September 19, 2016 at 14.04 m. Water level on October 4, 2016 at 11.67 m. Water level on November 23, 2016 at 12.44 m.									628
21											627
22											626
23											625
24											624
25											623
26											622
27											621
28											620
29											620
30											619

*Water level from water seepage observation during drilling ∇
 **Groundwater level measured on date indicated. ▼

STANTEC GEO 2016 123312651_AURUM_ROAD_BH_LOGS.GPJ MASTER1.GDT 2/23/17



BH08

CLIENT Aurum Industrial Development Partnership Borehole Coordinates PROJECT No. 123312651
 PROJECT Aurum Road Creek Crossing 44844 E BH ELEVATION 641.9m
 LOCATION Aurum Road 5939571 N DATUM: 3TM 114
 BORING DATES (mm/dd/yyyy): 9/9/2016 WATER LEVEL 11.98 m on 11.98 m on 10/4/2016

DEPTH(m)	ELEVATION(m)	SOIL DESCRIPTION	STRATA PLOT	SAMPLES				MONITOR WELL/ PIEZOMETER	Undrained Shear Strength (Cu) : (kPa) ▲ Cu based on Pocket Penetrometer : (kPa) ★		ELEVATION(m)
				TYPE	NUMBER	RECOVERY mm or CORE %	N-VALUE or RQD %		50	100	
0	641.90	CLAY TILL mixed with ORGANICS, some sand, trace gravel, dark brown, occasional rootlets		BS	1						641.90
	641.60										641.60
1		CLAY TILL (Cl), silty, some sand, trace gravel, stiff, brown, occasional oxide staining, occasional rootlets to 1.5 m									641
	640.40	sandy at 1.4 m									640
2		Light brown CLAY SHALE stratified with SANDSTONE, extremely weak, highly weathered - occasional oxide staining and coal fragments at 1.6 m		SS	2	380	13				640
3		- switch to rotary coring at 3.1 m		BS	3						639
4		- becomes light grey SANDSTONE stratified with brown CLAY SHALE below 3.2 m, oxide staining to 3.9 m - occasional coal fragments at 3.4 m		SS	4	400	28				638
				RC	1	88	89				638
5		- 50 mm oxidized coal seam at 4.9 m - iron stone nodules at 5.2 m - 100 mm bentonitic sandstone seam at 5.3 m		RC	2	100	93				637
6				RC	3	19	7				636
7		- 170 mm light brown bentonitic sandstone seam at 6.5 m - 50 mm medium strong bedrock at 6.6 m - iron stone nodules at 6.7 m									635
8		- iron stone nodules at 7.2 m - becomes grey CLAY SHALE stratified with SANDSTONE below 7.4 m		RC	4	84	50				634
	633.60	- sieve analysis on RC4 at 7.6 m [Sand: 2%, Silt: 49%, Clay: 49%]									634
9		- 20 mm oxidized sandstone seam at 8.7 m - occasional oxide staining at 8.7 m - 60 mm of weak bedrock at 8.9 m - 200 mm coal seam at 8.9 m - becomes dark grey below 9.1 m - becomes brown to dark grey below 9.8 m		RC	5	91	62				633
10											632

*Water level from water seepage observation during drilling ∇
 **Groundwater level measured on date indicated. ▼

STANTEC GEO 2016 123312651_AURUM_ROAD_BH_LOGS.GPJ MASTER1.GDT 2/23/17



BH08

CLIENT Aurum Industrial Development Partnership Borehole Coordinates PROJECT No. 123312651
 PROJECT Aurum Road Creek Crossing 44844 E BH ELEVATION 641.9m
 LOCATION Aurum Road 5939571 N DATUM: 3TM 114
 BORING DATES (mm/dd/yyyy): 9/9/2016 WATER LEVEL 11.98 m on 11.98 m on 10/4/2016

DEPTH(m)	ELEVATION(m)	SOIL DESCRIPTION	STRATA PLOT	SAMPLES				MONITOR WELLS/ PIEZOMETER	Undrained Shear Strength (Cu) : (kPa) ▲ Cu based on Pocket Penetrometer : (kPa) ★		ELEVATION(m)
				TYPE	NUMBER	RECOVERY mm or CORE %	N-VALUE or RQD %		50	100	
10		Dark grey to brown CLAY SHALE stratified with SANDSTONE, extremely weak, highly to completely weathered		RC	6	100	69				631
	629.92	- 100 mm of very weak bedrock with horizontal bedding at 11.6 m - 50 mm coal seam at 11.7 m - brown below 11.8 m		RC	7	100	77				630
		- 150 mm thick coal seam at 12.8 m									
		- 260 mm coal seam at 13.2 m - 200 mm coal seam at 13.7 m		RC	8	85	49				629
		- extremely weak to very weak bedrock to 14.4 m - becomes grey to brown below 14.0 m - completely weathered below 14.4 m									
	627.00			SS	5	420	73				628
15		Borehole completed at 14.9 m Upon completion on September 9, 2016: - no slough - water at 8.3 m after coring									627
16		Water level on September 10, 2016 at 7.93 m. Water level on September 12, 2016 at 7.91 m. Water level on September 13, 2016 at 8.20 m. Water level on October 4, 2016 at 11.98 m. Piezometer found damaged on November 23, 2016.									626
17		Vibrating wire piezometer installed on September 13, 2016 - tip installed at 13.6 m - slough to 13.8 m									625
18		- backfilled with grout from 13.8 m to ground surface - vibrating wire piezometer S/N: 1602056									624
19											623
20											622

*Water level from water seepage observation during drilling ∇
 **Groundwater level measured on date indicated. ▼

STANTEC GEO 2016 123312651_AURUM_ROAD_BH_LOGS.GPJ MASTER1.GDT 2/23/17



BH09

CLIENT Aurum Industrial Development Partnership Borehole Coordinates PROJECT No. 123312651
 PROJECT Aurum Road Creek Crossing 44941 E BH ELEVATION 634.6m
 LOCATION Aurum Road 5939593 N DATUM: 3TM114
 BORING DATES (mm/dd/yyyy): 9/14/2016 WATER LEVEL 2.7 m on 2.7 m on 9/15/2016

DEPTH(m)	ELEVATION(m)	SOIL DESCRIPTION	STRATA PLOT	SAMPLES				MONITOR WELL/ PIEZOMETER	Undrained Shear Strength (Cu) : (kPa) ▲ Cu based on Pocket Penetrometer : (kPa) ★		ELEVATION(m)	
				TYPE	NUMBER	RECOVERY mm or CORE %	N-VALUE or RQD %		50	100		150
0	634.60	CLAY TILL (CI), silty, some sand, trace gravel, firm, brown, occasional oxide staining, occasional coal fragments, occasional rootlets to 1.0 m - organic inclusions at 0.3 m - organic seams at 1.0 m - becomes reddish brown mottled with grey below 1.8 m		BS	1						634	
1				SS	2	390	9					633
2				BS	3							632.30
2.7	631.90	Dark brown CLAY SHALE stratified with SANDSTONE, extremely weak, highly weathered, thinly laminated horizontal bedding - becomes grey with slight brown hue below 3.2 m - switch to rotary coring at 3.8 m and becomes brown below - 200 mm coal seam - 250 mm weak strength bedrock at 6.0 m - 400 mm coal seam at 6.3 m - becomes grey below 6.7 m - 150 mm coal seam at 6.8 m - 70 mm of weak strength bedrock at 7.9 m - 130 mm of completely weathered bluish-grey sandstone with little plasticity at 8.2 m		SS	4	480	7					632
3				BS	5							631
4				SS	6	400	45					630
5				RC	1	86	48					629
6				RC	2	92	57					628
7				RC	3	100	93					627
8				RC	4	75	53					626
9												625
10		*Water level from water seepage observation during drilling ▽										

STANTEC GEO 2016 123312651_AURUM_ROAD_BH_LOGS.GPJ MASTER1.GDT 2/23/17



BH09

CLIENT Aurum Industrial Development Partnership Borehole Coordinates PROJECT No. 123312651
 PROJECT Aurum Road Creek Crossing 44941 E BH ELEVATION 634.6m
 LOCATION Aurum Road 5939593 N DATUM: 3TM 114
 BORING DATES (mm/dd/yyyy): 9/14/2016 WATER LEVEL 2.7 m on 2.7 m on 9/15/2016

DEPTH(m)	ELEVATION(m)	SOIL DESCRIPTION	STRATA PLOT	SAMPLES				MONITOR WELL/ PIEZOMETER	Undrained Shear Strength (Cu) : (kPa) ▲ Cu based on Pocket Penetrometer : (kPa) ★		ELEVATION(m)
				TYPE	NUMBER	RECOVERY mm or CORE %	N-VALUE or RQD %		50	100	
10	624	Grey SANDSTONE stratified with brown CLAY SHALE, extremely weak, highly weathered, thinly laminated horizontal bedding - 25 mm coal seam at 10.1 m		SS	7	430	81				
				RC	5	100	97				
11	623	- 300 mm of weak strength bedrock at 11.4 m									
12	622			RC	6	100	93				
13	621	- grey with horizontal laminations below 12.6 m									
14				RC	7	100	98				
15	620			SS	8	390	25/53				
16	619			RC	8	98	95				
17	618	- hydrometer test on RC9 at 15.9 m [Sand: 1%, Silt: 56%, Clay 43%] - occasional coal fragments from 16.1 m to 16.3 m - high plastic, slickensided from 16.6 m to 16.8 m - becomes brown to 16.9 m		RC	9	100	100				
18	617										
19	616	- 100 mm of weak strength bedrock at 17.9 m - becomes dark brown below 18.7 m - 100 mm of very weak strength bedrock at 18.8 m - becomes grey mottled with black below 18.9 m - high plastic below 19.4 m - 800 mm of very weak to weak strength bedrock		RC	10	100	100				
20	615			SS	9	470	76				
				RC	11	100	95				
*Water level from water seepage observation during drilling								▽			

STANTEC GEO 2016 123312651_AURUM_ROAD_BH_LOGS.GPJ MASTER1.GDT 2/23/17



BH09

CLIENT Aurum Industrial Development Partnership Borehole Coordinates PROJECT No. 123312651
 PROJECT Aurum Road Creek Crossing 44941 E BH ELEVATION 634.6m
 LOCATION Aurum Road 5939593 N DATUM: 3TM 114
 BORING DATES (mm/dd/yyyy): 9/14/2016 WATER LEVEL 2.7 m on 2.7 m on 9/15/2016

DEPTH(m)	ELEVATION(m)	SOIL DESCRIPTION	STRATA PLOT	SAMPLES				MONITOR WELL/ PIEZOMETER	Undrained Shear Strength (Cu) : (kPa) ▲ Cu based on Pocket Penetrometer : (kPa) ★		ELEVATION(m)
				TYPE	NUMBER	RECOVERY mm or CORE %	N-VALUE or RQD %		50	100	
20	614.20	Grey SANDSTONE stratified with brown CLAY SHALE, extremely weak, highly weathered, thinly laminated horizontal bedding									614
21		Borehole completed at 20.4 m Upon completion on September 15, 2016: - slough to 19.4 m - water at 2.7 m after coring - backfilled with cuttings from 1.0 m to 16.3 m - bentonite seal from 16.3 m to 19.4 m and from 1.0 m to ground surface									613
22											612
23											611
24											610
25											609
26											608
27											607
28											606
29											605
30											
*Water level from water seepage observation during drilling											

STANTEC GEO 2016 123312651_AURUM_ROAD_BH_LOGS.GPJ MASTER1.GDT 2/23/17



BH10

CLIENT Aurum Industrial Development Partnership Borehole Coordinates PROJECT No. 123312651
 PROJECT Aurum Road Creek Crossing 44878 E BH ELEVATION 632.7m
 LOCATION Aurum Road 5939620 N DATUM: 3TM114
 BORING DATES (mm/dd/yyyy): 9/12/2016 WATER LEVEL 3.04 m on 3.04 m on 11/23/2016

DEPTH(m)	ELEVATION(m)	SOIL DESCRIPTION	STRATA PLOT	SAMPLES				MONITOR WELL/ PIEZOMETER	Undrained Shear Strength (Cu) : (kPa) ▲ Cu based on Pocket Penetrometer : (kPa) ★		ELEVATION(m)
				TYPE	NUMBER	RECOVERY mm or CORE %	N-VALUE or RQD %		50	100	
	632.70	TOPSOIL (400 mm)									632.70
	632.30										
	632.10	CLAY mixed with ORGANICS, silty, some sand, dark brown to black, occasional rootlets		BS	1						
1		CLAY colluvium (CI), silty, sandy, trace gravel, firm, brown, occasional oxide staining, occasional rootlets to 1.0 m: - dark brown below 1.0 m		SS	2	280	8				
				BS	3						
2				SS	4	320	6				
				BS	5						
		- wood pieces at 2.5 m		SS	6	280	4				
		- wood pieces at 2.8 m		BS	7						
	629.66			SS	8	470	8				
		- wood pieces at 3.4 m		BS	9						
4		- increased gravel content at 3.5 m - seepage inferred at 3.8 m		SS	10	140	7				
				BS	11						
	628.10	Grey SANDSTONE stratified with brown CLAY SHALE, extremely weak, completely weathered		SS	12	170	6				
5		- 50 mm coal seam at 4.7 m - yellowish hue at 5.1 m - bluish-grey completely weathered sandstone with thinly laminated horizontal high plastic clay beds at 5.3 m		BS	13						
		- yellowish hue at 5.5 m - gravel plugged RC1 resulting in no recovery - switch to coring at 5.8 m		SS	14	370	29				
6				RC	1	0	0				
7		- becomes highly weathered grey sandstone below 6.9 m		RC	2	87	71				
8				SS	15	24018/50 (127m)					
9		- 40 mm of weak strength bedrock at 8.8 m - fragments of weak strength bedrock at 9.2 m - fragments of weak strength bedrock at 9.5 m		RC	3	95	69				
10											

*Water level from water seepage observation during drilling
 **Groundwater level measured on date indicated. ▼

STANTEC GEO 2016 123312651_AURUM_ROAD_BH_LOGS.GPJ MASTER1.GDT 2/23/17



BH10

CLIENT Aurum Industrial Development Partnership Borehole Coordinates PROJECT No. 123312651
 PROJECT Aurum Road Creek Crossing 44878 E BH ELEVATION 632.7m
 LOCATION Aurum Road 5939620 N DATUM: 3TM114
 BORING DATES (mm/dd/yyyy): 9/12/2016 WATER LEVEL 3.04 m on 3.04 m on 11/23/2016

DEPTH(m)	ELEVATION(m)	SOIL DESCRIPTION	STRATA PLOT	SAMPLES				MONITOR WELL/ PIEZOMETER	Undrained Shear Strength (Cu) : (kPa) ▲ Cu based on Pocket Penetrometer : (kPa) ★		ELEVATION(m)
				TYPE	NUMBER	RECOVERY mm or CORE %	N-VALUE or RQD %		50	100	
10		Grey SANDSTONE stratified with brown CLAY SHALE, extremely weak, highly weathered - 400 mm thick mudstone at 10.1 m		RC	4	100	78				622
11		- thin brown horizontal laminations at 10.8 m to 11.4 m - 300 mm of very weak strength bedrock below at 10.9 m		RC	5	100	83				621
12				SS	16	440	63				620
13		- becomes extremely weak to very weak with thin brown horizontal laminations below 13.0 m		RC	6	98	89				619
14				RC	7	100	100				618
15	617.80	- 25 mm coal seam at 14.7 m		SS	17	450	78				617
16		Borehole completed at 14.9 m Upon completion on September 13, 2016: - slough to 13.7 m - water at ground surface after coring - backfilled with sand from 10.7 m to 13.7 m - bentonite seal from 3.7 m to 10.7 m - cuttings from 3.7 m to ground surface									616
17		Water level on September 14, 2016 at 0.52 m. Water level on September 15, 2016 at 1.14 m. Water level on September 16, 2016 at 1.61 m. Water level on October 4, 2016 at 2.84 m. Water level on November 23, 2016 at 3.04 m.									615
18											614
19											613
20											

*Water level from water seepage observation during drilling
 **Groundwater level measured on date indicated. ▼

STANTEC GEO 2016 123312651_AURUM_ROAD_BH_LOGS.GPJ MASTER1.GDT 2/23/17



BH11

CLIENT Aurum Industrial Development Partnership Borehole Coordinates PROJECT No. 123312651
 PROJECT Aurum Road Creek Crossing 44939 E BH ELEVATION 643.7m
 LOCATION Aurum Road 5939625 N DATUM: 3TM114
 BORING DATES (mm/dd/yyyy): 9/12/2016 WATER LEVEL 13.7 m on 13.70 m on 11/23/2016

DEPTH(m)	ELEVATION(m)	SOIL DESCRIPTION	STRATA PLOT	SAMPLES				MONITOR WELL/ PIEZOMETER	Undrained Shear Strength (Cu) : (kPa) ▲ Cu based on Pocket Penetrometer : (kPa) ★		ELEVATION(m)
				TYPE	NUMBER	RECOVERY mm or CORE %	N-VALUE or RQD %		50	100	
0	643.70									643.70	
	643.40	SAND mixed with ORGANICS, clayey, dark brown, poorly graded, occasional rootlets, organic odor		BS	1						
	642.90	SAND, silty, trace gravel, light brown, poorly graded									
1		CLAY TILL (CH), silty, some sand, trace gravel, stiff, brown, occasional oxide staining, occasional rootlets to 1.2 m		SS	2	160	10				643
				BS	3						642
		- becomes hard below 2.3 m		SS	4	340	31				641
		- reddish-brown at 2.7 m		BS	5						640
		- becomes very stiff below 3.1 m		SS	6	350	22				639
		- yellowish brown and sandy below 3.4 m		BS	7						638
		becomes brown below 3.7 m		SS	8	270	17				637
				BS	9						636
				SS	10	240	14				635
				BS	11						634
				ST	12	290					633
				SS	13	450	18				632
	637.40	SAND and GRAVEL, dense, brown, poorly graded		SS	14	40	31				631
				BS	15						630
		- becomes compact below 7.6 m		SS	16	20	24				629
	635.80	CLAY TILL (CI), some sand, trace gravel, brown		BS	17						628
	635.60										627
	635.00	COAL (900 mm)									626
		- 400 mm of bedrock intermixed with coal at 9.2 m									625
		- switch to rotary coring at 9.2 m		SS	18	360	36				624
	634.10	- 50 mm wet coal seam with occasional oxide staining at 9.5 m		RC	1	100	100				623
10											622

STANTEC GEO 2016 123312651_AURUM_ROAD_BH_LOGS.GPJ MASTER1.GDT 2/23/17



BH11

CLIENT Aurum Industrial Development Partnership Borehole Coordinates PROJECT No. 123312651
 PROJECT Aurum Road Creek Crossing 44939 E BH ELEVATION 643.7m
 LOCATION Aurum Road 5939625 N DATUM: 3TM114
 BORING DATES (mm/dd/yyyy): 9/12/2016 WATER LEVEL 13.7 m on 13.70 m on 11/23/2016

DEPTH(m)	ELEVATION(m)	SOIL DESCRIPTION	STRATA PLOT	SAMPLES				MONITOR WELL/ PIEZOMETER	Undrained Shear Strength (Cu) : (kPa) ▲ Cu based on Pocket Penetrometer : (kPa) ★		ELEVATION(m)
				TYPE	NUMBER	RECOVERY mm or CORE %	N-VALUE or RQD %		50	100	
10		Grey-brown CLAY SHALE stratified with SANDSTONE, extremely weak, highly weathered - organic odour with brown oxidation stains to 11.1 m		RC	2	100	93				633
11											
12		- 3 mm coal seam at 11.7 m - 300 mm bluish-green and grey bentonitic shale at 12.0 m		RC	3	100	92				632
13		- 100 mm coal seam at 12.8 m									
14	630.00			RC	4	55	28				631
15		- 220 mm of medium strong bedrock at 14.4 m - 100 mm coal seam at 14.5 m - becomes mainly SANDSTONE below 14.7 m - becomes grey and completely weathered with some plasticity from 15.0 m to 15.2 m									630
16		Borehole completed at 15.7 m Upon completion on September 12, 2016: - slough to 14.8 m - water at 7.5 m after coring Water level on September 13, 2016 at 11.0 m. Water level on October 4, 2016 at 13.02 m. Water level on November 23, 2016 at 13.70 m.									629
17		Vibrating wire piezometer installed on September 13, 2016 - tip installed at 14.2 m - backfilled with grout from 14.8 m to 2.0 m - bentonite from 1.0 m to 2.0 m - sand from 1.0 m to ground surface - vibrating wire piezometer S/N: 1602057									628
18											627
19											626
20											625
											624

STANTEC GEO 2016 123312651_AURUM_ROAD_BH_LOGS.GPJ MASTER1.GDT 2/23/17

*Water level from water seepage observation during drilling ∇
 **Groundwater level measured on date indicated. ▼



BH12

CLIENT Aurum Industrial Development Partnership Borehole Coordinates PROJECT No. 123312651
 PROJECT Aurum Road Creek Crossing 44900 E BH ELEVATION 634.9m
 LOCATION Aurum Road 5939587 N DATUM: 3TM114
 BORING DATES (mm/dd/yyyy): 9/7/2016 WATER LEVEL 4.33 m on 4.33 m on 11/23/2016

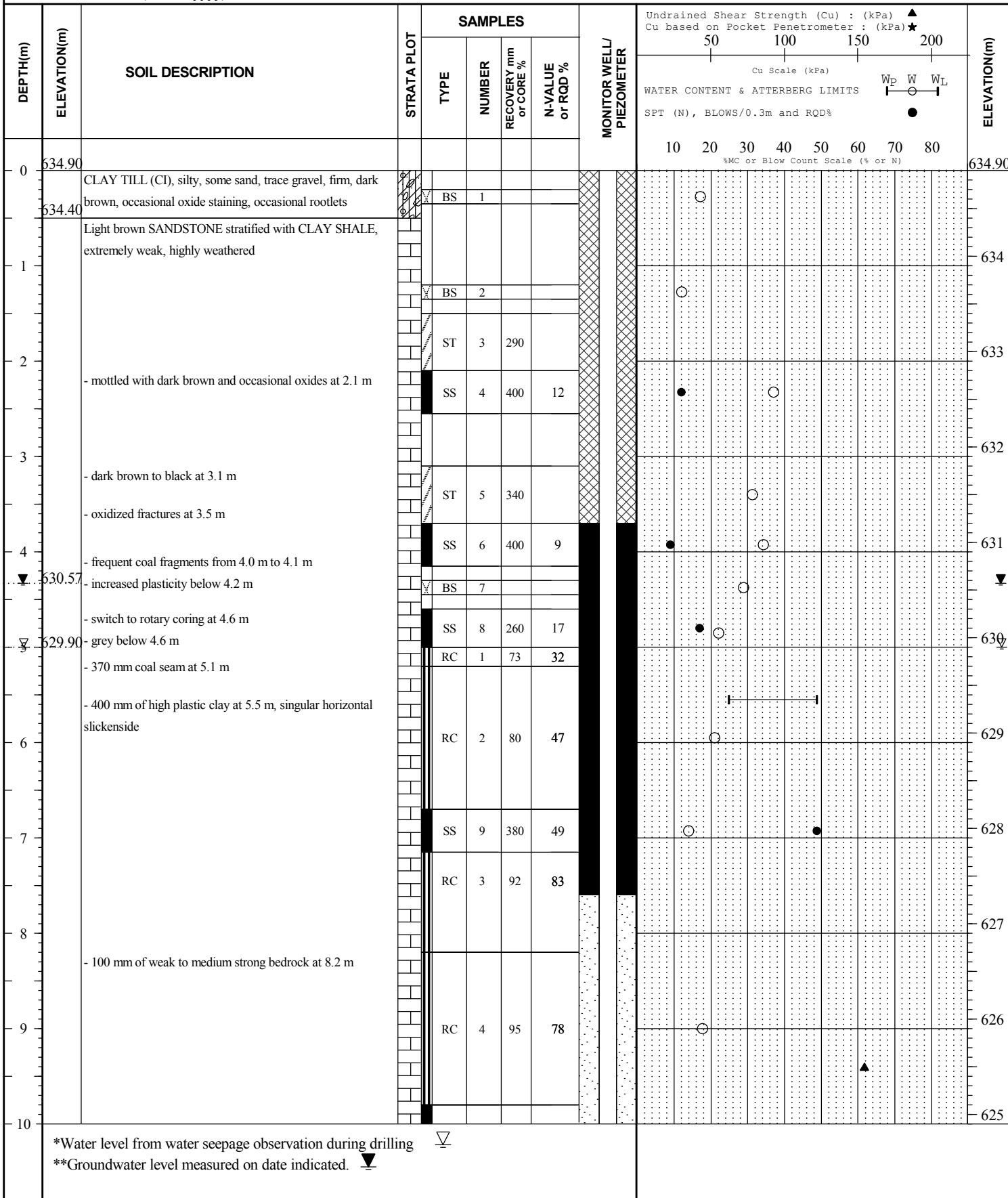

STANTEC GEO 2016 123312651_AURUM_ROAD_BH_LOGS.GPJ MASTER1.GDT 2/23/17



BH12

CLIENT Aurum Industrial Development Partnership Borehole Coordinates PROJECT No. 123312651
 PROJECT Aurum Road Creek Crossing 44900 E BH ELEVATION 634.9m
 LOCATION Aurum Road 5939587 N DATUM: 3TM114
 BORING DATES (mm/dd/yyyy): 9/7/2016 WATER LEVEL 4.33 m on 4.33 m on 11/23/2016

DEPTH(m)	ELEVATION(m)	SOIL DESCRIPTION	STRATA PLOT	SAMPLES				MONITOR WELLS/ PIEZOMETER	Undrained Shear Strength (Cu) : (kPa) ▲ Cu based on Pocket Penetrometer : (kPa) ★		ELEVATION(m)	
				TYPE	NUMBER	RECOVERY mm or CORE %	N-VALUE or RQD %		50	100		150
10		Grey SANDSTONE stratified with CLAY SHALE, extremely weak, highly weathered - SPT refusal on SS10 with blow counts of 27/29/60 for 89 mm - 70 mm of cemented bedrock at 10.3 m - occasional coal fragments at 11.0 m - 50 mm of weak bedrock at 11.3 m - 200 mm of cemented weak sandstone at 11.8 m	[Strata Plot]	SS	10	450	89					
	RC			5	65	47						
11												
12												
13	621.50			SS	11	500	64					
14		Borehole completed at 13.4 m Upon completion on September 8, 2016: - slough to 11.5 m - water at 5.0 m after coring - backfilled with sand from 7.6 m to 11.5 m - bentonite seal from 3.7 m to 7.6 m - cuttings from 3.7 m to ground surface Water level on September 9, 2016 at 4.22 m. Water level on September 10, 2016 at 4.25 m. Water level on September 12, 2016 at 4.14 m. Water level on September 13, 2016 at 4.24 m. Water level on September 17, 2016 at 4.34 m. Water level on September 19, 2016 at 4.24 m. Water level on October 4, 2016 at 4.26 m. Water level on November 23, 2016 at 4.33 m.										
15												
16												
17												
18												
19												
20												

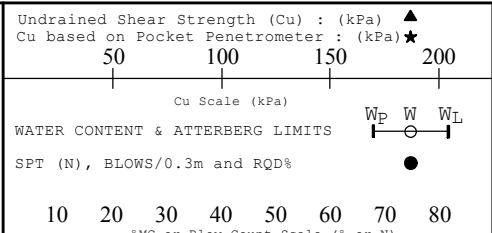

STANTEC GEO 2016 123312651_AURUM_ROAD_BH_LOGS.GPJ MASTER1.GDT 2/23/17

*Water level from water seepage observation during drilling ∇
 **Groundwater level measured on date indicated. ▼



BH13

CLIENT Aurum Industrial Development Partnership Borehole Coordinates PROJECT No. 123312651
 PROJECT Aurum Road Creek Crossing 44870 E BH ELEVATION 632.4m
 LOCATION Aurum Road 5939614 N DATUM: 3TM114
 BORING DATES (mm/dd/yyyy): 9/13/2016 WATER LEVEL 3 m on 3.00 m on 11/23/2016

DEPTH(m)	ELEVATION(m)	SOIL DESCRIPTION	STRATA PLOT	SAMPLES				MONITOR WELLS/ PIEZOMETER	Undrained Shear Strength (Cu) : (kPa) ▲ Cu based on Pocket Penetrometer : (kPa) ★		ELEVATION(m)
				TYPE	NUMBER	RECOVERY mm or CORE %	N-VALUE or RQD %		50	100	
0	632.40	TOPSOIL (500 mm)									632.40
	631.90										632
	631.60	CLAY mixed with ORGANICS, silty, some sand, dark brown to black, occasional rootlets, organic odor		BS	1						632
1		CLAY colluvium (CI), silty, some sand, trace gravel, firm, brown, occasional oxide staining, occasional coal fragments, occasional rootlets to 1.2 m - becomes grey to dark grey below 1.7 m		SS	2	360	7				631
2				BS	3						630
	629.70			ST	4	230					630
	629.40	- increased sand content at 2.9 m and becomes soft to firm below - wood pieces at 3.0 m		SS	5	380	5				629
	628.60	- rootlets from 3.0 m to 3.8 m		SS	6	400	4				629
4		- trace light grey bedrock pieces below 3.6 m - 40 mm coal seam with inferred seepage at 3.8 m		SS	7	240	8				628
		Grey SANDSTONE stratified with brown CLAY SHALE, extremely weak, completely weathered		BS	8						628
5		- switch to rotary coring at 5.0 m - becomes highly weathered below 5.2 m - occasional coal fragments at 5.3 m and 5.5 m - 400 mm of weak strength bedrock at 5.5 m		SS	9	530	26				627
6				RC	1	100	75				626
7											625
		- 100 mm of weak strength bedrock at 7.4 m		RC	2	96	87				625
8											624
				SS	10	330	46				624
9											623
		- 100 mm of very weak to weak strength bedrock at 9.3 m		RC	3	83	83				623
10											623

*Water level from water seepage observation during drilling ∇
 **Groundwater level measured on date indicated. ▼

STANTEC GEO 2016 123312651_AURUM_ROAD_BH_LOGS.GPJ MASTER1.GDT 2/23/17



BH13

CLIENT Aurum Industrial Development Partnership Borehole Coordinates PROJECT No. 123312651
 PROJECT Aurum Road Creek Crossing 44870 E BH ELEVATION 632.4m
 LOCATION Aurum Road 5939614 N DATUM: 3TM114
 BORING DATES (mm/dd/yyyy): 9/13/2016 WATER LEVEL 3 m on 3.00 m on 11/23/2016

DEPTH(m)	ELEVATION(m)	SOIL DESCRIPTION	STRATA PLOT	SAMPLES				MONITOR WELL/ PIEZOMETER	Undrained Shear Strength (Cu) : (kPa) ▲ Cu based on Pocket Penetrometer : (kPa) ★ 50 100 150 200 Cu Scale (kPa) WATER CONTENT & ATTERBERG LIMITS W _P W W _L SPT (N), BLOWS/0.3m and RQD% ● 10 20 30 40 50 60 70 80 %MC or Blow Count Scale (% or N)								ELEVATION(m)			
				TYPE	NUMBER	RECOVERY mm or CORE %	N-VALUE or RQD %													
10		Grey SANDSTONE stratified with brown CLAY SHALE, extremely weak, completely weathered, thinly laminated horizontal bedding		RC	4	100	100													622
11		- 5 mm coal seam at 11.5 m		SS	11	470	66													621
12				RC	5	97	94													620
13		- 50 mm of very weak strength bedrock		RC	6	100	75													619
14		- 10 mm coal seam at 14.4 m																		618
15		- 3 mm coal seam at 14.6 m		SS	12	370	75 (127m)													618
15		- 10 mm coal seam at 14.7 m																		617
15		- 200 mm of extremely weak to very weak strength bedrock at 13.0 m		RC	7	100	91													617
16		- becomes brown from 15.9 m to 16.0 m																		616
16		- grey with thin brown laminations below 16.2 m																		616
16		- 60 mm of very weak strength bedrock at 16.3 m		RC	8	100	90													616
16		- 3 mm coal seam at 16.5 m																		615
17		- 50 mm zone of thin brown laminations at approximately 45 degrees at 17.4 m		SS	13	440	78													615
18		- coal seam at 17.7 m less than 2 mm thick																		614
18		- 200 mm of very weak strength bedrock at 18.1 m		RC	9	100	98													614
19																				613
19																				613
20				RC	10	100	98													613

*Water level from water seepage observation during drilling ∇
 **Groundwater level measured on date indicated. ▼

STANTEC GEO 2016 123312651_AURUM_ROAD_BH_LOGS.GPJ MASTER1.GDT 2/23/17



BH13

CLIENT Aurum Industrial Development Partnership Borehole Coordinates PROJECT No. 123312651
 PROJECT Aurum Road Creek Crossing 44870 E BH ELEVATION 632.4m
 LOCATION Aurum Road 5939614 N DATUM: 3TM 114
 BORING DATES (mm/dd/yyyy): 9/13/2016 WATER LEVEL 3 m on 3.00 m on 11/23/2016

DEPTH(m)	ELEVATION(m)	SOIL DESCRIPTION	STRATA PLOT	SAMPLES				MONITOR WELL/ PIEZOMETER	Undrained Shear Strength (Cu) : (kPa) ▲ Cu based on Pocket Penetrometer : (kPa) ★		ELEVATION(m)
				TYPE	NUMBER	RECOVERY mm or CORE %	N-VALUE or RQD %		50	100	
20	612.00	Grey SANDSTONE stratified with brown CLAY SHALE, extremely weak, completely weathered, thinly laminated horizontal bedding									612
21		Borehole completed at 20.4 m Upon completion on September 14, 2016: - no slough - water at 2.7 m after coring - backfilled with grout from 20.4 m to ground surface									611
22		- vibrating wire piezometer installed at 20.1 m - vibrating wire piezometer S/N: 1602264 Water level on October 4, 2016 at 3.30 m. Water level on November 23, 2016 at 3.00 m.									610
23											609
24											608
25											607
26											606
27											605
28											604
29											603
30											

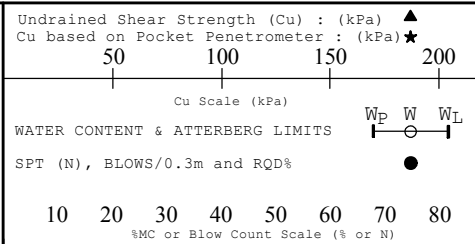

*Water level from water seepage observation during drilling ∇
 **Groundwater level measured on date indicated. ▼

STANTEC GEO 2016 123312651_AURUM_ROAD_BH_LOGS.GPJ MASTER1.GDT 2/23/17



BH14

CLIENT Aurum Industrial Development Partnership Borehole Coordinates PROJECT No. 123312651
 PROJECT Aurum Road Creek Crossing 44270 E BH ELEVATION 644.6m
 LOCATION Aurum Road 5939464 N DATUM: 3TM 114
 BORING DATES (mm/dd/yyyy): 9/19/2016 WATER LEVEL m on Dry on 9/19/2016

DEPTH(m)	ELEVATION(m)	SOIL DESCRIPTION	STRATA PLOT	SAMPLES				MONITOR WELL/ PIEZOMETER	Undrained Shear Strength (Cu) : (kPa) ▲ Cu based on Pocket Penetrometer : (kPa) ★		ELEVATION(m)
				TYPE	NUMBER	RECOVERY mm or CORE %	N-VALUE or RQD %		50	100	
0	644.60	TOPSOIL (400 mm)								644.60	
	644.20	CLAY TILL mixed with ORGANICS, some sand, trace gravel, black, occasional rootlets, organic odor		BS	1					644	
1	643.80	CLAY TILL (CI), silty, some sand, trace gravel, stiff, brown, occasional oxide staining, occasional coal fragments - hydrometer test on Bulk1 at 0.8 m [Gravel: 1%, Sand: 22%, Silt: 37%, Clay 40%]		SS	2	120	9			643	
2				BS	3					642	
				SS	4	500	9			641	
3				BS	5					640	
4	640.30	Borehole completed at 4.3 m Upon completion on September 19, 2016: - no slough and no water - bentonite seal from 1.2 m to ground surface - cuttings from 1.2 m to 4.3 m Bulk sample 1 obtained from 0.8 m to 2.3 m		SS	6	300	12			639	
5										638	
6										637	
7										636	
8										635	
9											
10											

STANTEC GEO 2016 123312651_AURUM_ROAD_BH_LOGS.GPJ MASTER1.GDT 2/23/17



BH15

CLIENT Aurum Industrial Development Partnership Borehole Coordinates PROJECT No. 123312651
 PROJECT Aurum Road Creek Crossing 44788 E BH ELEVATION 648.4m
 LOCATION Aurum Road 5939537 N DATUM: 3TM114
 BORING DATES (mm/dd/yyyy): 9/18/2016 WATER LEVEL 3.95 m on 3.95 m on 11/23/2016

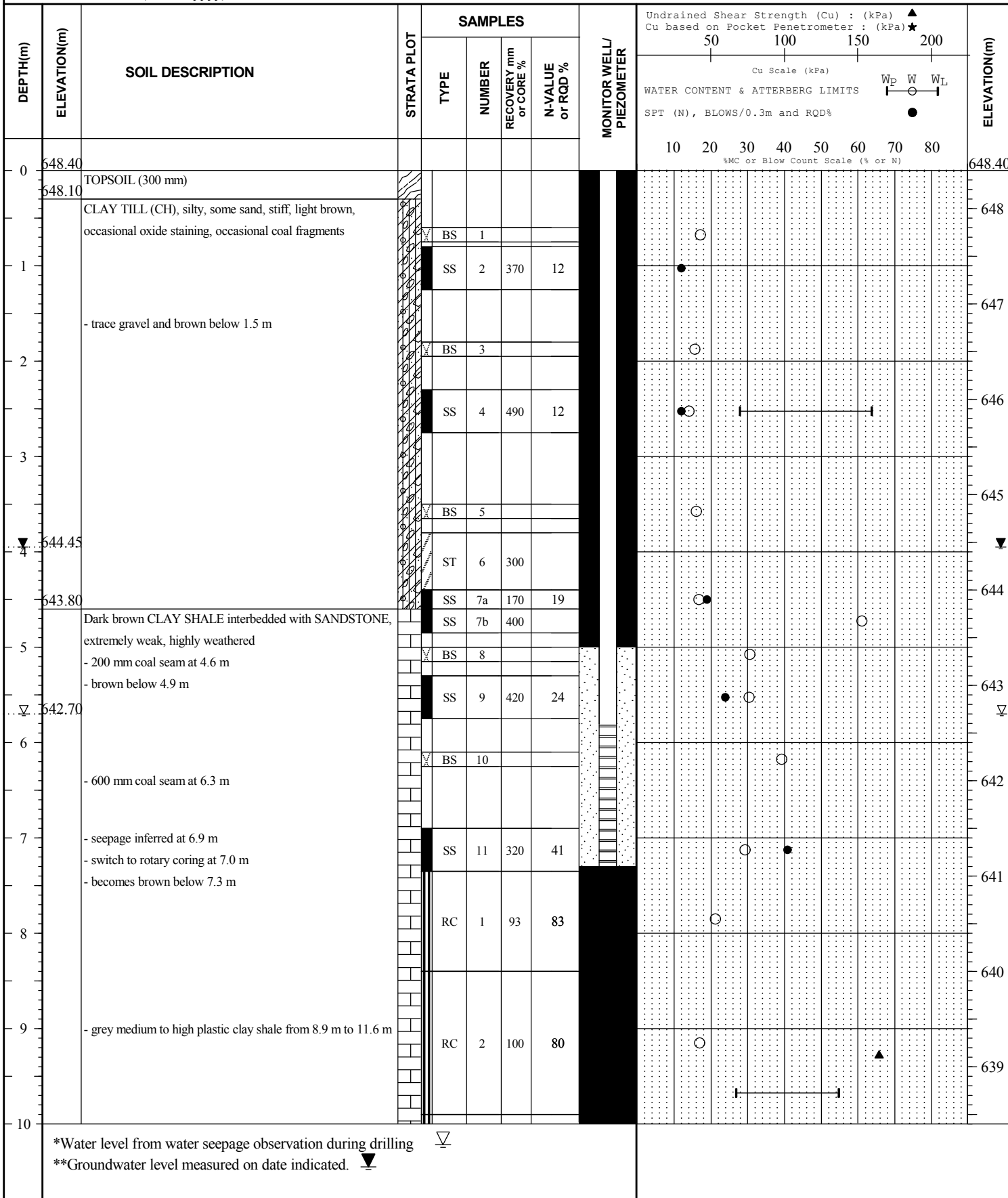

*Water level from water seepage observation during drilling ∇
 **Groundwater level measured on date indicated. ▼

STANTEC GEO 2016 123312651_AURUM_ROAD_BH_LOGS.GPJ MASTER1.GDT 2/23/17



BH15

CLIENT Aurum Industrial Development Partnership Borehole Coordinates PROJECT No. 123312651
 PROJECT Aurum Road Creek Crossing 44788 E BH ELEVATION 648.4m
 LOCATION Aurum Road 5939537 N DATUM: 3TM 114
 BORING DATES (mm/dd/yyyy): 9/18/2016 WATER LEVEL 3.95 m on 3.95 m on 11/23/2016

DEPTH(m)	ELEVATION(m)	SOIL DESCRIPTION	STRATA PLOT	SAMPLES				MONITOR WELL/ PIEZOMETER	Undrained Shear Strength (Cu) : (kPa) ▲ Cu based on Pocket Penetrometer : (kPa) ★		ELEVATION(m)
				TYPE	NUMBER	RECOVERY mm or CORE %	N-VALUE or RQD %		50	100	
10	638	Greyish-brown CLAY SHALE stratified with SANDSTONE, extremely weak, highly weathered		RC	3	100	89				
11	637	- grey sandstone thinly laminated with high plastic brown clay shale at 11.5 m									
12	636	- 160 mm of very weak bedrock		RC	4	100	100				
13	635	- becomes stratified SANDSTONE with CLAY SHALE below 13.0 m									
14	634	- 30 mm of medium strong bedrock at 13.5 m		RC	5	98	79				
15	633	- 160 mm of weak bedrock at 14.2 m									
16	632	- laminated at 14.7 m		RC	6	100	93				
17	631	- brown below 16.1 m									
18	630	- 380 mm coal seam at 16.6 m		RC	7	100	72				
19	629	- grey below and thinly laminated at 17.0 m									
20		- becomes brown below 17.6 m		RC	8	100	53				
		- 100 mm of medium strong bedrock at 18.8 m									
		- becomes brown CLAY SHALE stratified with grey SANDSTONE below 19.2 m		RC	9	100	89				

*Water level from water seepage observation during drilling ∇
 **Groundwater level measured on date indicated. ▼

STANTEC GEO 2016 123312651_AURUM_ROAD_BH_LOGS.GPJ MASTER1.GDT 2/23/17



BH15

CLIENT Aurum Industrial Development Partnership Borehole Coordinates PROJECT No. 123312651
 PROJECT Aurum Road Creek Crossing 44788 E BH ELEVATION 648.4m
 LOCATION Aurum Road 5939537 N DATUM: 3TM114
 BORING DATES (mm/dd/yyyy): 9/18/2016 WATER LEVEL 3.95 m on 3.95 m on 11/23/2016

DEPTH(m)	ELEVATION(m)	SOIL DESCRIPTION	STRATA PLOT	SAMPLES				MONITOR WELL/ PIEZOMETER	Undrained Shear Strength (Cu) : (kPa) ▲ Cu based on Pocket Penetrometer : (kPa) ★		ELEVATION(m)
				TYPE	NUMBER	RECOVERY mm or CORE %	N-VALUE or RQD %		50	100	
20	628	Brown CLAY SHALE stratified with grey SANDSTONE, extremely weak, highly weathered									628
		- 350 mm coal seam at 20.6 m									
21	627	- 500 mm coal seam at 21.2 m		RC	10	100	41				627
		- 50 mm very weak bedrock at 22.0 m									
		- becomes completely weathered grey SANDSTONE stratified with brown CLAY SHALE below 22.2 m		RC	11	87	54				626
23	625	- 200 mm of medium strong bedrock									625
		- 400 mm of completely weathered grey bentonitic sandstone at 23.6 m									
24	624	- very weak and grey below 23.7 m		RC	12	97	95				624
		- highly weathered and thinly laminated below 24.0 m									
25	623.30	- 40 mm of weak bedrock at 25.0 m									
		Borehole completed at 25.1 m									
		Upon completion on September 18, 2016:									
		- slough to 24.8 m									
26		- water at 5.7 m									
		- standpipe and vibrating wire installed									
		Water level in standpipe on September 19, 2016 at 7.93 m.									
		Water level in standpipe on October 4, 2016 at 4.01 m.									
27		Water level in standpipe on November 23, 2016 at 3.95 m.									
		Possibly damaged on October 4, 2016.									
		Possibly damaged on November 23, 2016.									
		Vibrating wire piezometer installed on September 18, 2016									
		- tip installed at 24.8 m									
28		- backfilled with sand from 21.8 m to 24.8 m and from 5.0 m to 7.3 m									
		- bentonite seal from 7.3 m to 21.8 m and from 5.0 m to ground surface									
29		- vibrating wire piezometer S/N: 1602263									
		Bulk sample 1 obtained from 0.5 m to 2.3 m.									
30											

*Water level from water seepage observation during drilling ∇
 **Groundwater level measured on date indicated. ▼

STANTEC GEO 2016 123312651_AURUM_ROAD_BH_LOGS.GPJ MASTER1.GDT 2/23/17



BH16

CLIENT Aurum Industrial Development Partnership Borehole Coordinates PROJECT No. 123312651
 PROJECT Aurum Road Creek Crossing 44524 E BH ELEVATION 645.7m
 LOCATION Aurum Road 5939590 N DATUM: 3TM114
 BORING DATES (mm/dd/yyyy): 9/19/2016 WATER LEVEL 7.65 m on 7.65 m on 11/23/2016

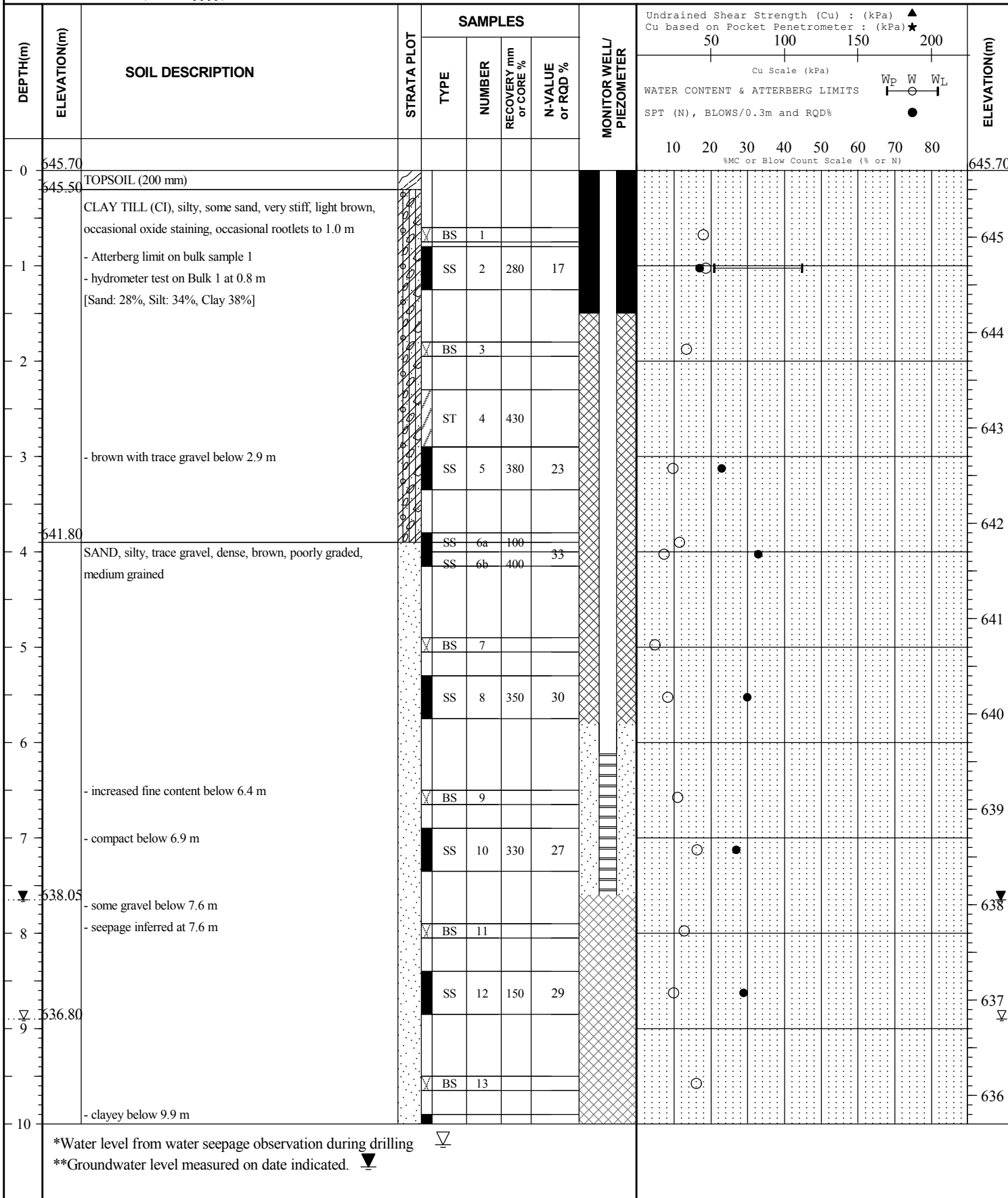

STANTEC GEO 2016 123312651_AURUM_ROAD_BH_LOGS.GPJ MASTER1.GDT 2/23/17



BH16

CLIENT Aurum Industrial Development Partnership Borehole Coordinates PROJECT No. 123312651
 PROJECT Aurum Road Creek Crossing 44524 E BH ELEVATION 645.7m
 LOCATION Aurum Road 5939590 N DATUM: 3TM 114
 BORING DATES (mm/dd/yyyy): 9/19/2016 WATER LEVEL 7.65 m on 7.65 m on 11/23/2016

DEPTH(m)	ELEVATION(m)	SOIL DESCRIPTION	STRATA PLOT	SAMPLES				MONITOR WELL/ PIEZOMETER	Undrained Shear Strength (Cu) : (kPa) ▲ Cu based on Pocket Penetrometer : (kPa) ★		ELEVATION(m)
				TYPE	NUMBER	RECOVERY mm or CORE %	N-VALUE or RQD %		50	100	
10	635.30	SAND, silty, clayey, trace gravel, dense, brown, poorly graded, medium grained		14	80	31		20	30	635	
11		Borehole completed at 10.4 m Upon completion on September 19, 2016: - slough to 7.6 m - water at 8.9 m - backfilled with sand from 5.8 m to 7.6 m - bentonite seal from 1.5 m to ground surface - cuttings from 1.5 m to 5.8 m								634	
12		Water level in standpipe on October 4, 2016 at 7.72 m. Water level in standpipe on November 23, 2016 at 7.65 m.								633	
13		Bulk Sample 1 obtained from 0.4 m to 2.3 m Bulk Sample 2 obtained from 4.5 m to 6.5 m								632	
14										631	
15										630	
16										629	
17										628	
18										627	
19										626	
20											

*Water level from water seepage observation during drilling ∇
 **Groundwater level measured on date indicated. ▼

STANTEC GEO 2016 123312651_AURUM_ROAD_BH_LOGS.GPJ MASTER1.GDT 2/23/17



BH17

CLIENT Aurum Industrial Development Partnership Borehole Coordinates PROJECT No. 123312651
 PROJECT Aurum Road Creek Crossing 44488 E BH ELEVATION 646.1m
 LOCATION Aurum Road 5939547 N DATUM: 3TM 114
 BORING DATES (mm/dd/yyyy): 9/19/2016 WATER LEVEL m on Dry on 11/23/2016

DEPTH(m)	ELEVATION(m)	SOIL DESCRIPTION	STRATA PLOT	SAMPLES				MONITOR WELL/ PIEZOMETER	Undrained Shear Strength (Cu) : (kPa) ▲ Cu based on Pocket Penetrometer : (kPa) ★		ELEVATION(m)
				TYPE	NUMBER	RECOVERY mm or CORE %	N-VALUE or RQD %		50	100	
0	646.10	TOPSOIL (300 mm)								646	
	645.80	CLAY TILL (CI), silty, some sand, very stiff, brown, occasional oxide staining, occasional rootlets to 1.0 m - Atterberg limit on bulk sample 1 - hydrometer test on Bulk1 at 0.8 m [Sand: 19%, Silt: 33%, Clay 48%]		BS 1							645
1				SS 2	200	16					
2				BS 3							644
		- trace gravel below 2.7 m		SS 4	400	17					
3	643.00	SAND, silty, dense, brown, poorly graded, medium grained, occasional oxide staining		BS 5							643
4		- trace gravel below 4.4 m		SS 6	450	30					642
5				BS 7							641
				SS 8	180	38					
6				BS 9							640
		- compact below 6.9 m - seepage inferred at 6.9 m		SS 10	230	17					639
7	638.80	CLAY TILL (CL), silty, sandy, very stiff, brown, occasional oxide staining		BS 11							638
8		- trace gravel below 8.4 m - occasional coal fragments at 8.4 m - some gravel below 8.8 m		SS 12	190	16					637
9				BS 13							
10											
*Water level from water seepage observation during drilling ∇											

STANTEC GEO 2016 123312651_AURUM_ROAD_BH_LOGS.GPJ MASTER1.GDT 2/23/17



BH17

CLIENT Aurum Industrial Development Partnership Borehole Coordinates PROJECT No. 123312651
 PROJECT Aurum Road Creek Crossing 44488 E BH ELEVATION 646.1m
 LOCATION Aurum Road 5939547 N DATUM: 3TM 114
 BORING DATES (mm/dd/yyyy): 9/19/2016 WATER LEVEL m on Dry on 11/23/2016

DEPTH(m)	ELEVATION(m)	SOIL DESCRIPTION	STRATA PLOT	SAMPLES				MONITOR WELL/ PIEZOMETER	Undrained Shear Strength (Cu) : (kPa) ▲ Cu based on Pocket Penetrometer : (kPa) ★ 50 100 150 200 Cu Scale (kPa) WATER CONTENT & ATTERBERG LIMITS W _P W W _L SPT (N), BLOWS/0.3m and RQD% ● 10 20 30 40 50 60 70 80 %MC or Blow Count Scale (% or N)								ELEVATION(m)
				TYPE	NUMBER	RECOVERY mm or CORE %	N-VALUE or RQD %										
10	635.70	CLAY TILL (CL), silty, sandy, some gravel, very stiff, brown, occasional oxide staining		SS	14	60	75										636
11		Borehole completed at 10.4 m Upon completion on September 19, 2016: - slough to 9.2 m - water at 8.5 m - backfilled with sand from 4.3 m to 6.1 m - bentonite seal from 6.1 m to 6.4 m and from 2.7 m to 4.3 m - cuttings from 6.4 m to 10.4 m and from 2.7 m to ground surface Dry on October 4, 2016. Dry on November 23, 2016.															635
12																	634
13																	633
14																	632
15																	631
16																	630
17																	629
18																	628
19																	627
20																	

*Water level from water seepage observation during drilling



BH18

CLIENT Aurum Industrial Development Partnership Borehole Coordinates PROJECT No. 123312651
 PROJECT Aurum Road Creek Crossing 44922 E BH ELEVATION 633.6m
 LOCATION Aurum Road 5939580 N DATUM: 3TM 114
 BORING DATES (mm/dd/yyyy): 9/20/2016 WATER LEVEL m on n/a

DEPTH(m)	ELEVATION(m)	SOIL DESCRIPTION	STRATA PLOT	SAMPLES				MONITOR WELL/ PIEZOMETER	Undrained Shear Strength (Cu) : (kPa) ▲ Cu based on Pocket Penetrometer : (kPa) ★		ELEVATION(m)
				TYPE	NUMBER	RECOVERY mm or CORE %	N-VALUE or RQD %		50	100	
0	633.60	TOPSOIL (200 mm)									633.60
	633.40	CLAY colluvium (Cl), silty, some sand, trace gravel, brown, occasional oxide staining, occasional coal fragments		BS	1						633
1				BS	2						632
2	631.60	- becomes grey below 1.7 m		BS	3						631
		Hand auger hole completed at 2.0 m Upon completion on September 20, 2016: - backfilled with cuttings from 2.0 m to ground surface									630
3											629
4											628
5											627
6											626
7											625
8											624
9											
10											

STANTEC GEO 2016 123312651_AURUM_ROAD_BH_LOGS.GPJ MASTER1.GDT 2/23/17



BH19

CLIENT Aurum Industrial Development Partnership Borehole Coordinates PROJECT No. 123312651
 PROJECT Aurum Road Creek Crossing 44899 E BH ELEVATION 633.2m
 LOCATION Aurum Road 5939594 N DATUM: 3TM 114
 BORING DATES (mm/dd/yyyy): 9/20/2016 WATER LEVEL m on n/a

DEPTH(m)	ELEVATION(m)	SOIL DESCRIPTION	STRATA PLOT	SAMPLES				MONITOR WELL/ PIEZOMETER	Undrained Shear Strength (Cu) : (kPa) ▲ Cu based on Pocket Penetrometer : (kPa) ★		ELEVATION(m)
				TYPE	NUMBER	RECOVERY mm or CORE %	N-VALUE or RQD %		50	100	
0	633.20	TOPSOIL (250 mm)								633	
	632.95	CLAY colluvium (Cl), silty, some sand, trace gravel, brown, occasional oxide staining, occasional rootlets		BS	1					633	
	632.60	Brown SANDSTONE with CLAY SHALE, extremely weak, completely weathered, thinly laminated, occasional oxide staining, occasional coal fragments		BS	2					632	
1	632.00	Hand auger hole completed at 1.2 m Upon completion on September 20, 2016: - backfilled with cuttings from 1.2 m to ground surface		BS	3					632	
2										631	
3										630	
4										629	
5										628	
6										627	
7										626	
8										625	
9										624	
10											

STANTEC GEO 2016 123312651_AURUM_ROAD_BH_LOGS.GPJ MASTER1.GDT 2/23/17



BH20

CLIENT Aurum Industrial Development Partnership Borehole Coordinates PROJECT No. 123312651
 PROJECT Aurum Road Creek Crossing 44867 E BH ELEVATION 635.3m
 LOCATION Aurum Road 5939582 N DATUM: 3TM114
 BORING DATES (mm/dd/yyyy): 9/20/2016 WATER LEVEL m on n/a

DEPTH(m)	ELEVATION(m)	SOIL DESCRIPTION	STRATA PLOT	SAMPLES				MONITOR WELL/ PIEZOMETER	Undrained Shear Strength (Cu) : (kPa) ▲ Cu based on Pocket Penetrometer : (kPa) ★		ELEVATION(m)
				TYPE	NUMBER	RECOVERY mm or CORE %	N-VALUE or RQD %		50	100	
0	635.30	TOPSOIL (350 mm)								635.30	
	634.95	CLAY colluvium (Cl), silty, some sand, trace gravel, brown, occasional oxide staining, occasional rootlets		BS	1					635	
1	634.50	Grey SANDSTONE with brown CLAY SHALE, extremely weak, completely weathered, thinly laminated, occasional oxide staining, occasional coal fragments		BS	2					634	
	633.70	Hand auger hole completed at 1.6 m Upon completion on September 20, 2016: - backfilled with cuttings from 1.6 m to ground surface		BS	3					634	
2										633	
3										632	
4										631	
5										630	
6										629	
7										628	
8										627	
9										626	
10											

STANTEC GEO 2016 123312651_AURUM_ROAD_BH_LOGS.GPJ MASTER1.GDT 2/23/17



BH21

CLIENT Aurum Industrial Development Partnership Borehole Coordinates PROJECT No. 123312651
 PROJECT Aurum Road Creek Crossing 44852 E BH ELEVATION 631.6m
 LOCATION Aurum Road 5939603 N DATUM: 3TM114
 BORING DATES (mm/dd/yyyy): 9/20/2016 WATER LEVEL m on n/a

DEPTH(m)	ELEVATION(m)	SOIL DESCRIPTION	STRATA PLOT	SAMPLES				MONITOR WELL/ PIEZOMETER	Undrained Shear Strength (Cu) : (kPa) ▲ Cu based on Pocket Penetrometer : (kPa) ★		ELEVATION(m)
				TYPE	NUMBER	RECOVERY mm or CORE %	N-VALUE or RQD %		50	100	
0	631.60	TOPSOIL (250 mm)								631.60	
	631.35	CLAY colluvium (Cl), silty, some sand, brown, occasional coal fragments - grey below 0.55 m - wood chips and organic pocket at 0.8 m - increased moisture content below - 10 mm sand seam at 1.6 m		BS	1						631
1				BS	2						630
2	629.60	Hand auger hole completed at 2.0 m Upon completion on September 20, 2016: - backfilled with cuttings from 2.0 m to ground surface		BS	3						629
3											628
4											627
5											626
6											625
7											624
8											623
9											622
10											

STANTEC GEO 2016 123312651_AURUM_ROAD_BH_LOGS.GPJ MASTER1.GDT 2/23/17



BH22

CLIENT Aurum Industrial Development Partnership Borehole Coordinates PROJECT No. 123312651
 PROJECT Aurum Road Creek Crossing 44869 E BH ELEVATION 630.4m
 LOCATION Aurum Road 5939602 N DATUM: 3TM 114
 BORING DATES (mm/dd/yyyy): 9/20/2016 WATER LEVEL m on n/a

DEPTH(m)	ELEVATION(m)	SOIL DESCRIPTION	STRATA PLOT	SAMPLES				MONITOR WELL/ PIEZOMETER	Undrained Shear Strength (Cu) : (kPa) ▲ Cu based on Pocket Penetrometer : (kPa) ★		ELEVATION(m)
				TYPE	NUMBER	RECOVERY mm or CORE %	N-VALUE or RQD %		50	100	
0	630.40	TOPSOIL (400 mm)									630.40
	630.00	SAND and GRAVEL, clayey, brown, poorly graded		BS	1						630
	629.60	CLAY colluvium (CI), silty, sandy, trace gravel, grey		BS	2						
1	629.10	- seepage inferred at 0.9 m		BS	3						
		- grinding sound with auger refusal at 1.3 m									629
		Hand auger hole completed at 1.3 m									
2		Upon completion on September 20, 2016: - backfilled with cuttings from 1.3 m to ground surface									628
3											627
4											626
5											625
6											624
7											623
8											622
9											621
10											

STANTEC GEO 2016 123312651_AURUM_ROAD_BH_LOGS.GPJ MASTER1.GDT 2/23/17



BH23

CLIENT Aurum Industrial Development Partnership Borehole Coordinates PROJECT No. 123312651
 PROJECT Aurum Road Creek Crossing 44908 E BH ELEVATION 632.8m
 LOCATION Aurum Road 5939613 N DATUM: 3TM 114
 BORING DATES (mm/dd/yyyy): 9/20/2016 WATER LEVEL m on n/a

DEPTH(m)	ELEVATION(m)	SOIL DESCRIPTION	STRATA PLOT	SAMPLES				MONITOR WELL/ PIEZOMETER	Undrained Shear Strength (Cu) : (kPa) ▲ Cu based on Pocket Penetrometer : (kPa) ★		ELEVATION(m)
				TYPE	NUMBER	RECOVERY mm or CORE %	N-VALUE or RQD %		50	100	
0	632.80	TOPSOIL (530 mm)								632.80	
1	632.27	CLAY colluvium (Cl), silty, some sand to sandy, occasional oxide staining		BS	1					632	
1	631.40			BS	2						
2	631.10	Grey SANDSTONE with brown CLAY SHALE, extremely weak, completely weathered, thinly laminated, occasional oxide staining		BS	3					631	
2		Hand auger hole completed at 1.7 m Upon completion on September 20, 2016: - backfilled with cuttings from 1.7 m to ground surface								630	
3										629	
4										628	
5										627	
6										626	
7										625	
8										624	
9										623	
10											

STANTEC GEO 2016 123312651_AURUM_ROAD_BH_LOGS.GPJ MASTER1.GDT 2/23/17



BH24

CLIENT Aurum Industrial Development Partnership Borehole Coordinates PROJECT No. 123312651
 PROJECT Aurum Road Creek Crossing 44924 E BH ELEVATION 632.4m
 LOCATION Aurum Road 5939600 N DATUM: 3TM 114
 BORING DATES (mm/dd/yyyy): 9/20/2016 WATER LEVEL m on n/a

DEPTH(m)	ELEVATION(m)	SOIL DESCRIPTION	STRATA PLOT	SAMPLES				MONITOR WELL/ PIEZOMETER	Undrained Shear Strength (Cu) : (kPa) ▲ Cu based on Pocket Penetrometer : (kPa) ★		ELEVATION(m)
				TYPE	NUMBER	RECOVERY mm or CORE %	N-VALUE or RQD %		50	100	
0	632.40	TOPSOIL (250 mm)									632.40
	632.15	CLAY colluvium (Cl), silty, some sand, occasional oxide staining - wood pieces and organics at 0.7 m - seepage inferred at 0.7 m		BS	1						632
1				BS	2						631
	630.90	Light brown and grey SANDSTONE and CLAY SHALE, extremely weak, completely weathered, thinly laminated		BS	3						631
2		- grinding sound with auger refusal at 1.7 m Hand auger hole completed at 1.7 m Upon completion on September 20, 2016: - backfilled with cuttings from 1.7 m to ground surface									630
3											629
4											628
5											627
6											626
7											625
8											624
9											623
10											

STANTEC GEO 2016 123312651_AURUM_ROAD_BH_LOGS.GPJ MASTER1.GDT 2/23/17

GEOTECHNICAL INVESTIGATION REPORT

February 24, 2017

Appendix D

Laboratory Test Results





Moisture Content of Soil or Aggregate
CSA A23.2-11A
ASTM D2216

OFFICE
 10160 - 112 ST
 Edmonton, Alberta
 Canada T5K 2L6

LABORATORY
 10575 106 ST
 Edmonton, Alberta
 Canada T5H 2X5

Tel: (780) 917-7000

Tel: (780) 917-7463

Project: Aurum Road Creek Crossing Date Tested: 22-Sep-16
 Client: Aurum Industrial Development Partnersh
 Project No.: 123312651 Tested By: JA

Moisture Content Worksheet							
Borehole / Test Pit No.	BH1	BH1	BH1	BH1	BH1	BH1	BH1
Sample	BS1	SS2	BS3	SS4	BS5	SS6	BS7
Tare No.	4M	Q1	20A	CT	CS	37A	15
Mass Tare Container	8.5	8.6	9.4	8.7	9.4	9.3	8.7
Mass Sample (Wet+Tare) (g)	101.5	129.9	120.8	184.3	125.5	164.5	164.4
Mass Sample (Dry+Tare) (g)	87.4	113.4	108.9	168	116	140.8	150.2
Mass of Water (g)	14.10	16.50	11.90	16.30	9.50	23.70	14.20
Mass Dry Sample (g)	78.90	104.80	99.50	159.30	106.60	131.50	141.50
Moisture Content (%)	17.9%	15.7%	12.0%	10.2%	8.9%	18.0%	10.0%
Comments							
Borehole / Test Pit No.	BH1	BH1	BH1	BH1	BH1	BH1	BH1
Sample	SS8	BS9	SS10	BS11	BS12	BS14	SS15
Tare No.	32A	13	CB	J2	D3	17	33A
Mass Tare Container	9.4	8.7	9.1	9.6	8.5	8.5	9.1
Mass Sample (Wet+Tare) (g)	109.6	199.1	113.1	196.9	182.8	121.9	74.6
Mass Sample (Dry+Tare) (g)	101.3	188.3	104.5	160.8	155.7	105.2	62.2
Mass of Water (g)	8.30	10.80	8.60	36.10	27.10	16.70	12.40
Mass Dry Sample (g)	91.90	179.60	95.40	151.20	147.20	96.70	53.10
Moisture Content (%)	9.0%	6.0%	9.0%	23.9%	18.4%	17.3%	23.4%
Comments							
Borehole / Test Pit No.	BH1						
Sample	SS13						
Tare No.	CL						
Mass Tare Container	8.5						
Mass Sample (Wet+Tare) (g)	89.3						
Mass Sample (Dry+Tare) (g)	79.7						
Mass of Water (g)	9.60						
Mass Dry Sample (g)	71.20						
Moisture Content (%)	13.5%						
Comments							
Borehole / Test Pit No.							
Sample							
Tare No.							
Mass Tare Container							
Mass Sample (Wet+Tare) (g)							
Mass Sample (Dry+Tare) (g)							
Mass of Water (g)							
Mass Dry Sample (g)							
Moisture Content (%)							
Comments							

Reviewed By: SAZ

Reporting of these test results constitutes a testing service only. Engineering interpretation or evaluation of the test results is provided only on written request. The data presented above is for the sole use of the client stipulated above. Stantec is not responsible, nor can be held liable, for the use of this report by any other party, with or without the knowledge of Stantec.



Moisture Content of Soil or Aggregate
CSA A23.2-11A
ASTM D2216

OFFICE
 10160 - 112 ST
 Edmonton, Alberta
 Canada T5K 2L6

LABORATORY
 10575 106 ST
 Edmonton, Alberta
 Canada T5H 2X5

Tel: (780) 917-7000

Tel: (780) 917-7463

Project: Aurum Road Creek Crossing Date Tested: 31-Oct-16
 Client: aurum Industrial Development Partnersh
 Project No.: 123312651 Tested By: JA

Moisture Content Worksheet							
Borehole / Test Pit No.	BH2	BH6	BH6	BH6	BH9	BH9	BH12
Sample	RC4	RC5	RC9	ST5	RC2	RC9	RC4
Tare No.	C17	C20	19B	AR	7B	C2	E4
Mass Tare Container	14.6	14.7	16	233.8	16.9	13.2	14.4
Mass Sample (Wet+Tare) (g)	816.3	831.8	769.5	1476.5	717.3	866.1	807.5
Mass Sample (Dry+Tare) (g)	703.3	738.4	666.1	1276.5	622.6	715.5	698
Mass of Water (g)	113.00	93.40	103.40	200.00	94.70	150.60	109.50
Mass Dry Sample (g)	688.70	723.70	650.10	1042.70	605.70	702.30	683.60
Moisture Content (%)	16.4%	12.9%	15.9%	19.2%	15.6%	21.4%	16.0%
Comments	11.97M - 12.17M	18.9M	24.7M	3.1M - 3.5M	5.76M - 5.93M	17.11M - 17.3M	9.3M
Borehole / Test Pit No.	BH10	BH13	BH15				
Sample	RC6	RC1	RC2				
Tare No.	C49	C72	D2				
Mass Tare Container	13.4	13.6	16.3				
Mass Sample (Wet+Tare) (g)	754.7	859.4	858.6				
Mass Sample (Dry+Tare) (g)	642.5	733.6	717.1				
Mass of Water (g)	112.20	125.80	141.50				
Mass Dry Sample (g)	629.10	720.00	700.80				
Moisture Content (%)	17.8%	17.5%	20.2%				
Comments	14.26M - 14.5M	6.35M	9.17M - 9.39M				
Borehole / Test Pit No.							
Sample							
Tare No.							
Mass Tare Container							
Mass Sample (Wet+Tare) (g)							
Mass Sample (Dry+Tare) (g)							
Mass of Water (g)							
Mass Dry Sample (g)							
Moisture Content (%)							
Comments							
Borehole / Test Pit No.							
Sample							
Tare No.							
Mass Tare Container							
Mass Sample (Wet+Tare) (g)							
Mass Sample (Dry+Tare) (g)							
Mass of Water (g)							
Mass Dry Sample (g)							
Moisture Content (%)							
Comments							

Reviewed By:

Reporting of these test results constitutes a testing service only. Engineering interpretation or evaluation of the test results is provided only on written request. The data presented above is for the sole use of the client stipulated above. Stantec is not responsible, nor can be held liable, for the use of this report by any other party, with or without the knowledge of Stantec.



Moisture Content of Soil or Aggregate
CSA A23.2-11A
ASTM D2216

OFFICE
 10160 - 112 ST
 Edmonton, Alberta
 Canada T5K 2L6

LABORATORY
 10575 106 ST
 Edmonton, Alberta
 Canada T5H 2X5

Tel: (780) 917-7000

Tel: (780) 917-7463

Project: Aurum Road Creek Crossing Date Tested: 12-Sep-16
 Client: Aurum Industrial Development Partnersh
 Project No.: 123312651 Tested By: JA

Moisture Content Worksheet							
Borehole / Test Pit No.	BH2	BH2	BH2	BH2	BH2	BH2	BH2
Sample	BS1	SS2	BS3	BS4	SS5A	SS5B	BS6
Tare No.	2	CM	EK	CL	17	33A	D3
Mass Tare Container	8.6	8.7	8.5	8.6	8.6	9.2	8.6
Mass Sample (Wet+Tare) (g)	105.4	164.1	153.1	223.8	91.3	112.7	132.4
Mass Sample (Dry+Tare) (g)	84.8	133.7	125.6	188.3	76.7	82.4	100.1
Mass of Water (g)	20.60	30.40	27.50	35.50	14.60	30.30	32.30
Mass Dry Sample (g)	76.20	125.00	117.10	179.70	68.10	73.20	91.50
Moisture Content (%)	27.0%	24.3%	23.5%	19.8%	21.4%	41.4%	35.3%
Comments							
Borehole / Test Pit No.	BH2	BH2	BH2	BH2	BH2	BH2	BH2
Sample	SS7	BS8	SS9	BS10	SS11	BS12	SS14
Tare No.	J2	CB	32A	16	CT	J4	DD
Mass Tare Container	9.1	9	9.4	8.6	8.6	9.2	9.1
Mass Sample (Wet+Tare) (g)	115.7	153.4	117.4	130.8	145.5	114	126
Mass Sample (Dry+Tare) (g)	86.2	115.8	91.5	98.7	110.9	87.4	105.5
Mass of Water (g)	29.50	37.60	25.90	32.10	34.60	26.60	20.50
Mass Dry Sample (g)	77.10	106.80	82.10	90.10	102.30	78.20	96.40
Moisture Content (%)	38.3%	35.2%	31.5%	35.6%	33.8%	34.0%	21.3%
Comments							
Borehole / Test Pit No.	BH2	BH2	BH2	BH2	BH2		
Sample	SS15	BS16	SS17	SS18	SS19		
Tare No.	222	9	DB	ZZ1	D13		
Mass Tare Container	9	8.6	8.7	8.5	8.5		
Mass Sample (Wet+Tare) (g)	126.4	200.7	101.6	114	108.4		
Mass Sample (Dry+Tare) (g)	104.2	166.2	87.6	98.7	92.4		
Mass of Water (g)	22.20	34.50	14.00	15.30	16.00		
Mass Dry Sample (g)	95.20	157.60	78.90	90.20	83.90		
Moisture Content (%)	23.3%	21.9%	17.7%	17.0%	19.1%		
Comments							
Borehole / Test Pit No.							
Sample							
Tare No.							
Mass Tare Container							
Mass Sample (Wet+Tare) (g)							
Mass Sample (Dry+Tare) (g)							
Mass of Water (g)							
Mass Dry Sample (g)							
Moisture Content (%)							
Comments							

Reviewed By: 

Reporting of these test results constitutes a testing service only. Engineering interpretation or evaluation of the test results is provided only on written request. The data presented above is for the sole use of the client stipulated above. Stantec is not responsible, nor can be held liable, for the use of this report by any other party, with or without the knowledge of Stantec.



Moisture Content of Soil or Aggregate
CSA A23.2-11A
ASTM D2216

OFFICE
 10160 - 112 ST
 Edmonton, Alberta
 Canada T5K 2L6

LABORATORY
 10575 106 ST
 Edmonton, Alberta
 Canada T5H 2X5

Tel: (780) 917-7000

Tel: (780) 917-7463

Project:	<u>Aurum Road Creek Crossing</u>	Date Tested:	<u>26-Oct-16</u>
Client:	<u>rum Industrial Development Partnersh</u>	Tested By:	<u>JA</u>
Project No.:	<u>123312651</u>		

Moisture Content Worksheet							
Borehole / Test Pit No.	BH3	BH3	BH3	BH3	BH3	BH3	BH3
Sample	RC5	RC4	RC1	RC6	RC3	RC2	RC5
Tare No.	CN	D5	114	D22	13	15A	2A
Mass Tare Container	8.6	8.5	8.6	8.4	8.6	9.3	9.2
Mass Sample (Wet+Tare) (g)	97.2	104.1	137.9	156	112.3	128.3	269.9
Mass Sample (Dry+Tare) (g)	85.5	92.1	122	133.6	92.1	117.5	229.3
Mass of Water (g)	11.70	12.00	15.90	22.40	20.20	10.80	40.60
Mass Dry Sample (g)	76.90	83.60	113.40	125.20	83.50	108.20	220.10
Moisture Content (%)	15.2%	14.4%	14.0%	17.9%	24.2%	10.0%	18.4%
Comments	LAMINATED BENTONITE						
Borehole / Test Pit No.	BH4	BH4	BH4	BH4	BH4		
Sample	RC5	RC3	RC2	RC6	RC4		
Tare No.	ER	SAM	2	EK	DU		
Mass Tare Container	8.5	9.1	8.4	8.3	8.4		
Mass Sample (Wet+Tare) (g)	143.1	164.7	151.1	126.6	110		
Mass Sample (Dry+Tare) (g)	125	139.5	125.6	108.4	97.6		
Mass of Water (g)	18.10	25.20	25.50	18.20	12.40		
Mass Dry Sample (g)	116.50	130.40	117.20	100.10	89.20		
Moisture Content (%)	15.5%	19.3%	21.8%	18.2%	13.9%		
Comments							
Borehole / Test Pit No.	BH5	BH5	BH5	BH5			
Sample	RC1	RC3	RC4	RC2			
Tare No.	CC	CK	EF	EDF			
Mass Tare Container	9.2	8.4	8.6	8.5			
Mass Sample (Wet+Tare) (g)	215.3	170.2	240.8	122.5			
Mass Sample (Dry+Tare) (g)	185.6	136.2	202.9	102.6			
Mass of Water (g)	29.70	34.00	37.90	19.90			
Mass Dry Sample (g)	176.40	127.80	194.30	94.10			
Moisture Content (%)	16.8%	26.6%	19.5%	21.1%			
Comments							
Borehole / Test Pit No.							
Sample							
Tare No.							
Mass Tare Container							
Mass Sample (Wet+Tare) (g)							
Mass Sample (Dry+Tare) (g)							
Mass of Water (g)							
Mass Dry Sample (g)							
Moisture Content (%)							
Comments							

Reviewed By: 

Reporting of these test results constitutes a testing service only. Engineering interpretation or evaluation of the test results is provided only on written request. The data presented above is for the sole use of the client stipulated above. Stantec is not responsible, nor can be held liable, for the use of this report by any other party, with or without the knowledge of Stantec.



Moisture Content of Soil or Aggregate
CSA A23.2-11A
ASTM D2216

OFFICE
 10160 - 112 ST
 Edmonton, Alberta
 Canada T5K 2L6

LABORATORY
 10575 106 ST
 Edmonton, Alberta
 Canada T5H 2X5

Tel: (780) 917-7000

Tel: (780) 917-7463

Project: Aurum Road Creek Crossing Date Tested: 12-Sep-16
 Client: Aurum Industrial Development Partnersh
 Project No.: 123312651 Tested By: JA

Moisture Content Worksheet							
Borehole / Test Pit No.	BH3	BH3	BH3	BH3	BH3	BH3	BH3
Sample	BS1	SS3	BS4	SS5	BS6	SS7	BS8
Tare No.	CH	EW	EH	CW	36A	DW	28
Mass Tare Container	9.3	8.7	8.5	8.5	9.3	8.6	9.2
Mass Sample (Wet+Tare) (g)	113.8	68.3	115.6	66.4	130.5	126.7	128.9
Mass Sample (Dry+Tare) (g)	93.4	48.2	89.6	52.5	102.3	99.3	107.4
Mass of Water (g)	20.40	20.10	26.00	13.90	28.20	27.40	21.50
Mass Dry Sample (g)	84.10	39.50	81.10	44.00	93.00	90.70	98.20
Moisture Content (%)	24.3%	50.9%	32.1%	31.6%	30.3%	30.2%	21.9%
Comments							
Borehole / Test Pit No.	BH3	BH3	Near BH3	Near BH3			
Sample	SS9	SS10		S&G			
Tare No.	EP	96	CY	3			
Mass Tare Container	8.6	8.6	8.6	8.7			
Mass Sample (Wet+Tare) (g)	122.7	144.6	129.9	142.5			
Mass Sample (Dry+Tare) (g)	100.8	122.4	110.3	136.3			
Mass of Water (g)	21.90	22.20	19.60	6.20			
Mass Dry Sample (g)	92.20	113.80	101.70	127.60			
Moisture Content (%)	23.8%	19.5%	19.3%	4.9%			
Comments			OUTCROP NEAR BH3	OPUTCROP NEAR BH3			
Borehole / Test Pit No.	BH8	BH8	BH8	BH8	BH8		
Sample	BS1	SS2	BS3	SS4	BSS5		
Tare No.	8	IGGY	D19	D9	30A		
Mass Tare Container	8.7	8.4	8.5	8.5	9.3		
Mass Sample (Wet+Tare) (g)	212.9	129.5	201.7	121.3	141.2		
Mass Sample (Dry+Tare) (g)	178.8	109	171.2	103.6	121.3		
Mass of Water (g)	34.10	20.50	30.50	17.70	19.90		
Mass Dry Sample (g)	170.10	100.60	162.70	95.10	112.00		
Moisture Content (%)	20.0%	20.4%	18.7%	18.6%	17.8%		
Comments							
Borehole / Test Pit No.							
Sample							
Tare No.							
Mass Tare Container							
Mass Sample (Wet+Tare) (g)							
Mass Sample (Dry+Tare) (g)							
Mass of Water (g)							
Mass Dry Sample (g)							
Moisture Content (%)							
Comments							

Reviewed By: 

Reporting of these test results constitutes a testing service only. Engineering interpretation or evaluation of the test results is provided only on written request. The data presented above is for the sole use of the client stipulated above. Stantec is not responsible, nor can be held liable, for the use of this report by any other party, with or without the knowledge of Stantec.



Moisture Content of Soil or Aggregate
CSA A23.2-11A
ASTM D2216

OFFICE
 10160 - 112 ST
 Edmonton, Alberta
 Canada T5K 2L6

LABORATORY
 10575 106 ST
 Edmonton, Alberta
 Canada T5H 2X5

Tel: (780) 917-7000

Tel: (780) 917-7463

Project: Aurum Road Creek Crossing Date Tested: 16-Sep-16
 Client: Aurum Industrial Development Partnersh
 Project No.: 123312651 Tested By: JA

Moisture Content Worksheet							
Borehole / Test Pit No.	BH4	BH4	BH4	BH4	BH4	BH4	BH4
Sample	BS1	BS2	SS3	BS4	SS5	BS6	SS7
Tare No.	EP	30A	EU	DT	DC	EA	77A
Mass Tare Container	8.6	9.4	8.7	8.6	8.7	8.7	9.3
Mass Sample (Wet+Tare) (g)	140.6	148	132.9	171.1	136.8	112.8	89.2
Mass Sample (Dry+Tare) (g)	135.1	145.7	129.4	167.4	132.7	99.5	75.2
Mass of Water (g)	5.50	2.30	3.50	3.70	4.10	13.30	14.00
Mass Dry Sample (g)	126.50	136.30	120.70	158.80	124.00	90.80	65.90
Moisture Content (%)	4.3%	1.7%	2.9%	2.3%	3.3%	14.6%	21.2%
Comments							
Borehole / Test Pit No.	BH4	BH4	BH4	BH4			
Sample	BS8	SS9	SS10	SS11			
Tare No.	14A	D20	RJ	CF			
Mass Tare Container	9.3	9	8.6	9.3			
Mass Sample (Wet+Tare) (g)	125.2	155.1	144	181.1			
Mass Sample (Dry+Tare) (g)	86	121.4	128.2	158.3			
Mass of Water (g)	39.20	33.70	15.80	22.80			
Mass Dry Sample (g)	76.70	112.40	119.60	149.00			
Moisture Content (%)	51.1%	30.0%	13.2%	15.3%			
Comments							
Borehole / Test Pit No.	BH9	BH9	BH9	BH9	BH9	BH9	BH9
Sample	BS1	SS2	BS3	SS4	BS5	SS6	SS7
Tare No.	4A	ZZ3	EM	SO	CS	7	DH
Mass Tare Container	9.3	8.5	8.7	8.7	8.7	8.8	9.1
Mass Sample (Wet+Tare) (g)	131.2	122.7	172.7	113.3	198.6	166.5	202.2
Mass Sample (Dry+Tare) (g)	116.1	111.6	131.7	87.6	163.7	141.2	176.9
Mass of Water (g)	15.10	11.10	41.00	25.70	34.90	25.30	25.30
Mass Dry Sample (g)	106.80	103.10	123.00	78.90	155.00	132.40	167.80
Moisture Content (%)	14.1%	10.8%	33.3%	32.6%	22.5%	19.1%	15.1%
Comments							
Borehole / Test Pit No.	BH9	BH9					
Sample	SS8	SS9					
Tare No.	IB	15A					
Mass Tare Container	8.6	9.6					
Mass Sample (Wet+Tare) (g)	136.4	120.9					
Mass Sample (Dry+Tare) (g)	116.9	103.5					
Mass of Water (g)	19.50	17.40					
Mass Dry Sample (g)	108.30	93.90					
Moisture Content (%)	18.0%	18.5%					
Comments							

Reviewed By:

Reporting of these test results constitutes a testing service only. Engineering interpretation or evaluation of the test results is provided only on written request. The data presented above is for the sole use of the client stipulated above. Stantec is not responsible, nor can be held liable, for the use of this report by any other party, with or without the knowledge of Stantec.



Moisture Content of Soil or Aggregate
CSA A23.2-11A
ASTM D2216

OFFICE
 10160 - 112 ST
 Edmonton, Alberta
 Canada T5K 2L6

LABORATORY
 10575 106 ST
 Edmonton, Alberta
 Canada T5H 2X5

Tel: (780) 917-7000

Tel: (780) 917-7463

Project: Aurum Road Creek Crossing Date Tested: 26-Oct-16
 Client: Aurum Industrial Development Partnersh
 Project No.: 123312651 Tested By: JA

Moisture Content Worksheet							
Borehole / Test Pit No.	BH6	BH6	BH6	BH6	BH6	BH6	BH6
Sample	RC3	RC1	RC5	RC6	RC4	RC2	RC8
Tare No.	CA	Q4	DW	D9	7	D19	115
Mass Tare Container	8.8	8.5	8.6	8.5	8.6	8.7	8.5
Mass Sample (Wet+Tare) (g)	197	115.1	88.1	159.1	179.9	161	184.1
Mass Sample (Dry+Tare) (g)	162.8	92.9	74.2	133.8	151.2	136.1	161.5
Mass of Water (g)	34.20	22.20	13.90	25.30	28.70	24.90	22.60
Mass Dry Sample (g)	154.00	84.40	65.60	125.30	142.60	127.40	153.00
Moisture Content (%)	22.2%	26.3%	21.2%	20.2%	20.1%	19.5%	14.8%
Comments							
Borehole / Test Pit No.	BH6	BH6					
Sample	RC7	RC9					
Tare No.	9	27A					
Mass Tare Container	8.5	9.3					
Mass Sample (Wet+Tare) (g)	209.6	219.9					
Mass Sample (Dry+Tare) (g)	182	186.5					
Mass of Water (g)	27.60	33.40					
Mass Dry Sample (g)	173.50	177.20					
Moisture Content (%)	15.9%	18.8%					
Comments							
Borehole / Test Pit No.							
Sample							
Tare No.							
Mass Tare Container							
Mass Sample (Wet+Tare) (g)							
Mass Sample (Dry+Tare) (g)							
Mass of Water (g)							
Mass Dry Sample (g)							
Moisture Content (%)							
Comments							
Borehole / Test Pit No.							
Sample							
Tare No.							
Mass Tare Container							
Mass Sample (Wet+Tare) (g)							
Mass Sample (Dry+Tare) (g)							
Mass of Water (g)							
Mass Dry Sample (g)							
Moisture Content (%)							
Comments							

Reviewed By: 

Reporting of these test results constitutes a testing service only. Engineering interpretation or evaluation of the test results is provided only on written request. The data presented above is for the sole use of the client stipulated above. Stantec is not responsible, nor can be held liable, for the use of this report by any other party, with or without the knowledge of Stantec.



Moisture Content of Soil or Aggregate
CSA A23.2-11A
ASTM D2216

OFFICE
 10160 - 112 ST
 Edmonton, Alberta
 Canada T5K 2L6

LABORATORY
 10575 106 ST
 Edmonton, Alberta
 Canada T5H 2X5

Tel: (780) 917-7000

Tel: (780) 917-7463

Project: Aurum Road Creek Crossing Date Tested: 22-Sep-16
 Client: Aurum Industrial Development Partnersh
 Project No.: 123312651 Tested By: JA

Moisture Content Worksheet							
Borehole / Test Pit No.	BH6	BH6	BH6	BH6	BH6	BH6	BH6
Sample	BS1	SS3	BS4	SS6	SS7	BS8	SS9
Tare No.	EX	EP	30A	EV	DT	DC	EA
Mass Tare Container	8.5	8.5	9.3	8.7	8.5	8.6	8.6
Mass Sample (Wet+Tare) (g)	110.6	138.5	177	119.6	86.5	113.8	116.5
Mass Sample (Dry+Tare) (g)	100.7	111.1	154.8	105.9	85.4	111.6	113.3
Mass of Water (g)	9.90	27.40	22.20	13.70	1.10	2.20	3.20
Mass Dry Sample (g)	92.20	102.60	145.50	97.20	76.90	103.00	104.70
Moisture Content (%)	10.7%	26.7%	15.3%	14.1%	1.4%	2.1%	3.1%
Comments							
Borehole / Test Pit No.	BH6	BH6	BH6	BH6	BH6	BH6	BH6
Sample	BS10	SS11	BS12	SS13	BS12	SS15	SS16
Tare No.	77A	14A	D20	RJ	CF	4A	DT
Mass Tare Container	9.2	9.2	8.8	8.4	9.2	9.2	9
Mass Sample (Wet+Tare) (g)	189.8	152.7	116.5	77.5	116.1	168.2	113.7
Mass Sample (Dry+Tare) (g)	161.8	128.6	101.5	61.7	93.5	142.4	97.8
Mass of Water (g)	28.00	24.10	15.00	15.80	22.60	25.80	15.90
Mass Dry Sample (g)	152.60	119.40	92.70	53.30	84.30	133.20	88.80
Moisture Content (%)	18.3%	20.2%	16.2%	29.6%	26.8%	19.4%	17.9%
Comments							
Borehole / Test Pit No.	BH6						
Sample	BS2						
Tare No.	ZZ3						
Mass Tare Container	8.4						
Mass Sample (Wet+Tare) (g)	105.1						
Mass Sample (Dry+Tare) (g)	84.5						
Mass of Water (g)	20.60						
Mass Dry Sample (g)	76.10						
Moisture Content (%)	27.1%						
Comments							
Borehole / Test Pit No.							
Sample							
Tare No.							
Mass Tare Container							
Mass Sample (Wet+Tare) (g)							
Mass Sample (Dry+Tare) (g)							
Mass of Water (g)							
Mass Dry Sample (g)							
Moisture Content (%)							
Comments							

Reviewed By: 

Reporting of these test results constitutes a testing service only. Engineering interpretation or evaluation of the test results is provided only on written request. The data presented above is for the sole use of the client stipulated above. Stantec is not responsible, nor can be held liable, for the use of this report by any other party, with or without the knowledge of Stantec.



Moisture Content of Soil or Aggregate
CSA A23.2-11A
ASTM D2216

OFFICE
 10160 - 112 ST
 Edmonton, Alberta
 Canada T5K 2L6

LABORATORY
 10575 106 ST
 Edmonton, Alberta
 Canada T5H 2X5

Tel: (780) 917-7000

Tel: (780) 917-7463

Project: Aurum Road Creek Crossing Date Tested: 22-Sep-16
 Client: Aurum Industrial Development Partnersh
 Project No.: 123312651 Tested By: JA

Moisture Content Worksheet							
Borehole / Test Pit No.	BH7	BH7	BH7	BH7	BH7	BH7	BH7
Sample	BS1	BS2	SS3	BS4	SS5	BS6	SS7
Tare No.	EM	SO	CS	C5	7	DH	15A
Mass Tare Container	8.5	8.6	9.4	8.5	8.7	9	9.4
Mass Sample (Wet+Tare) (g)	161	177.3	126.7	122.5	118.8	103.3	60.8
Mass Sample (Dry+Tare) (g)	137.2	148.5	111.6	112.3	109.8	95	59.8
Mass of Water (g)	23.80	28.80	15.10	10.20	9.00	8.30	1.00
Mass Dry Sample (g)	128.70	139.90	102.20	103.80	101.10	86.00	50.40
Moisture Content (%)	18.5%	20.6%	14.8%	9.8%	8.9%	9.7%	2.0%
Comments							
Borehole / Test Pit No.	BH7	BH7	BH7	BH7	BH7	BH7	BH7
Sample	BS8	SS9	BS10	BS11	SS12	BS13	SS14
Tare No.	IB	EE	114	EV	CL	7A	EI
Mass Tare Container	8.4	8.7	8.6	8.7	9.3	9.2	8.6
Mass Sample (Wet+Tare) (g)	77.1	111.3	75.3	65.3	77.5	162.2	50.4
Mass Sample (Dry+Tare) (g)	74.6	99.7	62.6	45.6	61.4	130.5	46
Mass of Water (g)	2.50	11.60	12.70	19.70	16.10	31.70	4.40
Mass Dry Sample (g)	66.20	91.00	54.00	36.90	52.10	121.30	37.40
Moisture Content (%)	3.8%	12.7%	23.5%	53.4%	30.9%	26.1%	11.8%
Comments							
Borehole / Test Pit No.	BH7	BH7	BH7	BH7	BH7	BH7	BH7
Sample	BS15	SS16	BS17	BS18	SS19	BS20	BS22
Tare No.	21A	CK	38	DJ	D22	DI	D24
Mass Tare Container	9.2	8.5	9.2	8.6	8.6	8.6	8.5
Mass Sample (Wet+Tare) (g)	166.5	93.4	144	165	106.6	130.6	91.4
Mass Sample (Dry+Tare) (g)	152.5	85.2	131.7	136.4	85.8	109.3	74.3
Mass of Water (g)	14.00	8.20	12.30	28.60	20.80	21.30	17.10
Mass Dry Sample (g)	143.30	76.70	122.50	127.80	77.20	100.70	65.80
Moisture Content (%)	9.8%	10.7%	10.0%	22.4%	26.9%	21.2%	26.0%
Comments							
Borehole / Test Pit No.	BH7	BH7	BH7	BH7	BH7		
Sample	SS23	BS24	SS25	BS26	SS27		
Tare No.	EC	FB	EH	36A	DW		
Mass Tare Container	8.5	8.6	8.5	9.3	8.5		
Mass Sample (Wet+Tare) (g)	99.5	85	124.7	94.8	52.4		
Mass Sample (Dry+Tare) (g)	83.6	73.7	102.9	75	38.7		
Mass of Water (g)	15.90	11.30	21.80	19.80	13.70		
Mass Dry Sample (g)	75.10	65.10	94.40	65.70	30.20		
Moisture Content (%)	21.2%	17.4%	23.1%	30.1%	45.4%		
Comments					COAL		

Reviewed By:

Reporting of these test results constitutes a testing service only. Engineering interpretation or evaluation of the test results is provided only on written request. The data presented above is for the sole use of the client stipulated above. Stantec is not responsible, nor can be held liable, for the use of this report by any other party, with or without the knowledge of Stantec.



Moisture Content of Soil or Aggregate
CSA A23.2-11A
ASTM D2216

OFFICE
 10160 - 112 ST
 Edmonton, Alberta
 Canada T5K 2L6

LABORATORY
 10575 106 ST
 Edmonton, Alberta
 Canada T5H 2X5

Tel: (780) 917-7000

Tel: (780) 917-7463

Project: Aurum Road Creek Crossing Date Tested: 26-Oct-16
 Client: urum Industrial Development Partnersh
 Project No.: 123312651 Tested By: JA

Moisture Content Worksheet							
Borehole / Test Pit No.	BH9	BH9	BH9	BH9	BH9	BH9	BH9
Sample	RC7	RC4	RC3	RC9	RC10	RC11	RC8
Tare No.	EI	ET	20A	Q1	4M	Q11	D7
Mass Tare Container	8.4	8.7	9.3	8.6	8.3	8.5	8.3
Mass Sample (Wet+Tare) (g)	204.9	118.1	270.8	71.3	294.4	171.2	141.2
Mass Sample (Dry+Tare) (g)	174.8	100	235.9	60.5	252.5	148.7	122.8
Mass of Water (g)	30.10	18.10	34.90	10.80	41.90	22.50	18.40
Mass Dry Sample (g)	166.40	91.30	226.60	51.90	244.20	140.20	114.50
Moisture Content (%)	18.1%	19.8%	15.4%	20.8%	17.2%	16.0%	16.1%
Comments							
Borehole / Test Pit No.	BH9	BH9	BH9				
Sample	RC6	RC5	RC2				
Tare No.	17A	96	34A				
Mass Tare Container	8.6	8.7	9				
Mass Sample (Wet+Tare) (g)	132.4	99.2	132.8				
Mass Sample (Dry+Tare) (g)	115	87.7	116.2				
Mass of Water (g)	17.40	11.50	16.60				
Mass Dry Sample (g)	106.40	79.00	107.20				
Moisture Content (%)	16.4%	14.6%	15.5%				
Comments							
Borehole / Test Pit No.	BH10	BH10	BH10	BH10	BH10		
Sample	RC6	RC4	RC3	RC5	RC2		
Tare No.	3	EZ	96	14A	DN		
Mass Tare Container	8.5	8.4	8.4	9.3	9		
Mass Sample (Wet+Tare) (g)	124.3	174.2	140.5	126.4	149.9		
Mass Sample (Dry+Tare) (g)	105	148.7	122.5	109.1	132.4		
Mass of Water (g)	19.30	25.50	18.00	17.30	17.50		
Mass Dry Sample (g)	96.50	140.30	114.10	99.80	123.40		
Moisture Content (%)	20.0%	18.2%	15.8%	17.3%	14.2%		
Comments							
Borehole / Test Pit No.	BH11	BH11	BH11	BH11			
Sample	RC2	RC3	RC4	RC5			
Tare No.	27A	12	19	EA			
Mass Tare Container	9.2	8.5	8.5	8.6			
Mass Sample (Wet+Tare) (g)	185.7	127.2	117.7	204.7			
Mass Sample (Dry+Tare) (g)	155.3	109.5	96.6	180.3			
Mass of Water (g)	30.40	17.70	21.10	24.40			
Mass Dry Sample (g)	146.10	101.00	88.10	171.70			
Moisture Content (%)	20.8%	17.5%	24.0%	14.2%			
Comments		12.4-12.5M		14.7-14.8M			

Reviewed By:

Reporting of these test results constitutes a testing service only. Engineering interpretation or evaluation of the test results is provided only on written request. The data presented above is for the sole use of the client stipulated above. Stantec is not responsible, nor can be held liable, for the use of this report by any other party, with or without the knowledge of Stantec.



Moisture Content of Soil or Aggregate
CSA A23.2-11A
ASTM D2216

OFFICE
 10160 - 112 ST
 Edmonton, Alberta
 Canada T5K 2L6

LABORATORY
 10575 106 ST
 Edmonton, Alberta
 Canada T5H 2X5

Tel: (780) 917-7000

Tel: (780) 917-7463

Project: Aurum Road Creek Crossing Date Tested: 13-Sep-16
 Client: Aurum Industrial Development Partnersh
 Project No.: 123312651 Tested By: JA

Moisture Content Worksheet							
Borehole / Test Pit No.	BH10	BH10	BH10	BH10	BH10	BH10	BH10
Sample	BS1	SS2	BS3	SS4	BS5	SS6	BS7
Tare No.	RJ	CE	4A	DT	D21	D23	CA
Mass Tare Container	8.5	9.2	9.2	9	8.6	8.5	9.1
Mass Sample (Wet+Tare) (g)	111.8	99.4	135.4	141	133.9	83.6	125
Mass Sample (Dry+Tare) (g)	95.6	80.6	103.4	106.7	100.7	63.3	94.8
Mass of Water (g)	16.20	18.80	32.00	34.30	33.20	20.30	30.20
Mass Dry Sample (g)	87.10	71.40	94.20	97.70	92.10	54.80	85.70
Moisture Content (%)	18.6%	26.3%	34.0%	35.1%	36.0%	37.0%	35.2%
Comments							
Borehole / Test Pit No.	BH10	BH10	BH10	BH10	BH10	BH10	BH10
Sample	SS8	BS9	SS10	BS11	SS12	SS13	SS14
Tare No.	15A	IB	CS	SO	EM	ZZ3	EE
Mass Tare Container	9.5	8.5	8.6	8.6	8.6	8.5	8.8
Mass Sample (Wet+Tare) (g)	116.5	98.3	107.6	120.6	79.7	133.8	168.8
Mass Sample (Dry+Tare) (g)	84.9	79.7	89.5	102.1	59.7	108.4	141.5
Mass of Water (g)	31.60	18.60	18.10	18.50	20.00	25.40	27.30
Mass Dry Sample (g)	75.40	71.20	80.90	93.50	51.10	99.90	132.70
Moisture Content (%)	41.9%	26.1%	22.4%	19.8%	39.1%	25.4%	20.6%
Comments							
Borehole / Test Pit No.	BH10	BH10	BH10				
Sample	SS15	SS16	SS17				
Tare No.	C5	CS	EE				
Mass Tare Container	9.3	9.3	8.7				
Mass Sample (Wet+Tare) (g)	119.8	172.2	121.5				
Mass Sample (Dry+Tare) (g)	102.6	148.9	102.1				
Mass of Water (g)	17.20	23.30	19.40				
Mass Dry Sample (g)	93.30	139.60	93.40				
Moisture Content (%)	18.4%	16.7%	20.8%				
Comments							
Borehole / Test Pit No.							
Sample							
Tare No.							
Mass Tare Container							
Mass Sample (Wet+Tare) (g)							
Mass Sample (Dry+Tare) (g)							
Mass of Water (g)							
Mass Dry Sample (g)							
Moisture Content (%)							
Comments							

Reviewed By: 

Reporting of these test results constitutes a testing service only. Engineering interpretation or evaluation of the test results is provided only on written request. The data presented above is for the sole use of the client stipulated above. Stantec is not responsible, nor can be held liable, for the use of this report by any other party, with or without the knowledge of Stantec.



Moisture Content of Soil or Aggregate
CSA A23.2-11A
ASTM D2216

OFFICE
 10160 - 112 ST
 Edmonton, Alberta
 Canada T5K 2L6

LABORATORY
 10575 106 ST
 Edmonton, Alberta
 Canada T5H 2X5

Tel: (780) 917-7000

Tel: (780) 917-7463

Project: Aurum Road Creek Crossing Date Tested: 13-Sep-16
 Client: Aurum Industrial Development Partnersh
 Project No.: 123312651 Tested By: JA

Moisture Content Worksheet							
Borehole / Test Pit No.	BH11	BH11	BH11	BH11	BH11	BH11	BH11
Sample	BS1	SS2	BS3	SS4	BS5	SS6	BS7
Tare No.	D23	14A	27A	EA	DC	DT	EU
Mass Tare Container	9	9.3	9.2	8.6	8.6	8.5	8.7
Mass Sample (Wet+Tare) (g)	124.7	70.8	168.6	91.4	59.1	95.9	91.5
Mass Sample (Dry+Tare) (g)	118.5	62.6	145.5	78.5	48.1	77.6	83.3
Mass of Water (g)	6.20	8.20	23.10	12.90	11.00	18.30	8.20
Mass Dry Sample (g)	109.50	53.30	136.30	69.90	39.50	69.10	74.60
Moisture Content (%)	5.7%	15.4%	16.9%	18.5%	27.8%	26.5%	11.0%
Comments							
Borehole / Test Pit No.	BH11	BH11	BH11	BH11	BH11	BH11	BH11
Sample	SS8	BS9	SS10	BS11	SS13	SS14	BS15
Tare No.	30A	D9	D19	IGGY	6	DW	36A
Mass Tare Container	9.3	8.4	8.5	8.4	8.6	8.6	9.3
Mass Sample (Wet+Tare) (g)	151.5	227.6	144.1	122.9	142.4	24.7	130.7
Mass Sample (Dry+Tare) (g)	127.9	188.2	122.1	101.1	117.8	23.5	124.4
Mass of Water (g)	23.60	39.40	22.00	21.80	24.60	1.20	6.30
Mass Dry Sample (g)	118.60	179.80	113.60	92.70	109.20	14.90	115.10
Moisture Content (%)	19.9%	21.9%	19.4%	23.5%	22.5%	8.1%	5.5%
Comments							
Borehole / Test Pit No.	BH11	BH11	BH11				
Sample	SS16	BS17	SS18				
Tare No.	CW	FB	EH				
Mass Tare Container	8.5	8.6	8.6				
Mass Sample (Wet+Tare) (g)	20.4	164.6	73.3				
Mass Sample (Dry+Tare) (g)	19.3	132.1	53.4				
Mass of Water (g)	1.10	32.50	19.90				
Mass Dry Sample (g)	10.80	123.50	44.80				
Moisture Content (%)	10.2%	26.3%	44.4%				
Comments							
Borehole / Test Pit No.							
Sample							
Tare No.							
Mass Tare Container							
Mass Sample (Wet+Tare) (g)							
Mass Sample (Dry+Tare) (g)							
Mass of Water (g)							
Mass Dry Sample (g)							
Moisture Content (%)							
Comments							

Reviewed By: 

Reporting of these test results constitutes a testing service only. Engineering interpretation or evaluation of the test results is provided only on written request. The data presented above is for the sole use of the client stipulated above. Stantec is not responsible, nor can be held liable, for the use of this report by any other party, with or without the knowledge of Stantec.



Moisture Content of Soil or Aggregate
CSA A23.2-11A
ASTM D2216

OFFICE
 10160 - 112 ST
 Edmonton, Alberta
 Canada T5K 2L6

LABORATORY
 10575 106 ST
 Edmonton, Alberta
 Canada T5H 2X5

Tel: (780) 917-7000

Tel: (780) 917-7463

Project: Aurum Road Creek Crossing Date Tested: 26-Oct-16
 Client: Aurum Industrial Development Partnersh
 Project No.: 123312651 Tested By: JA

Moisture Content Worksheet							
Borehole / Test Pit No.	BH12	BH12	BH12	BH12	BH12		
Sample	RC6	RC5	RC2	RC4	ST5		
Tare No.	CK	D20	DC	EP	36A		
Mass Tare Container	9.1	8.5	8.6	8.3	9.3		
Mass Sample (Wet+Tare) (g)	136.7	165.4	207.5	130.5	114.8		
Mass Sample (Dry+Tare) (g)	121.1	145.6	172.8	112	89.6		
Mass of Water (g)	15.60	19.80	34.70	18.50	25.20		
Mass Dry Sample (g)	112.00	137.10	164.20	103.70	80.30		
Moisture Content (%)	13.9%	14.4%	21.1%	17.8%	31.4%		
Comments							
Borehole / Test Pit No.	BH13	BH13	BH13	BH13	BH13	BH13	BH13
Sample	RC4	RC3	RC7	RC8	RC6	RC2	RC9
Tare No.	SO	ED	30A	ZZ1	D1	D23	D13
Mass Tare Container	8.4	8.7	9.3	8.4	8.5	8.5	8.4
Mass Sample (Wet+Tare) (g)	205.4	71.4	141.7	173.6	128.9	177	68
Mass Sample (Dry+Tare) (g)	175.5	63.1	115	143.7	100.6	148	58.8
Mass of Water (g)	29.90	8.30	26.70	29.90	28.30	29.00	9.20
Mass Dry Sample (g)	167.10	54.40	105.70	135.30	92.10	139.50	50.40
Moisture Content (%)	17.9%	15.3%	25.3%	22.1%	30.7%	20.8%	18.3%
Comments	10.4-10.5M	8.89-8.97M					
Borehole / Test Pit No.	BH13						
Sample	RC10						
Tare No.	DJ						
Mass Tare Container	9						
Mass Sample (Wet+Tare) (g)	109.1						
Mass Sample (Dry+Tare) (g)	92.6						
Mass of Water (g)	16.50						
Mass Dry Sample (g)	83.60						
Moisture Content (%)	19.7%						
Comments							
Borehole / Test Pit No.							
Sample							
Tare No.							
Mass Tare Container							
Mass Sample (Wet+Tare) (g)							
Mass Sample (Dry+Tare) (g)							
Mass of Water (g)							
Mass Dry Sample (g)							
Moisture Content (%)							
Comments							

Reviewed By: 

Reporting of these test results constitutes a testing service only. Engineering interpretation or evaluation of the test results is provided only on written request. The data presented above is for the sole use of the client stipulated above. Stantec is not responsible, nor can be held liable, for the use of this report by any other party, with or without the knowledge of Stantec.



Moisture Content of Soil or Aggregate
CSA A23.2-11A
ASTM D2216

OFFICE
 10160 - 112 ST
 Edmonton, Alberta
 Canada T5K 2L6

LABORATORY
 10575 106 ST
 Edmonton, Alberta
 Canada T5H 2X5

Tel: (780) 917-7000

Tel: (780) 917-7463

Project: Aurum Road Creek Crossing Date Tested: 12-Sep-16
 Client: Aurum Industrial Development Partnersh
 Project No.: 123312651 Tested By: JA

Moisture Content Worksheet							
Borehole / Test Pit No.	BH12	BH12	BH12	BH12	BH12	BH12	BH12
Sample	BS1	BS2	SS4	SS6	BS7	SS8	SS9
Tare No.	EU	DT	DC	EA	27A	19A	D20
Mass Tare Container	8.7	8.6	8.7	8.7	9.3	9.3	8.8
Mass Sample (Wet+Tare) (g)	137.1	117.8	89.1	107.6	106.6	99.7	187.1
Mass Sample (Dry+Tare) (g)	118.3	106	67.3	82.3	84.7	83.3	165.2
Mass of Water (g)	18.80	11.80	21.80	25.30	21.90	16.40	21.90
Mass Dry Sample (g)	109.60	97.40	58.60	73.60	75.40	74.00	156.40
Moisture Content (%)	17.2%	12.1%	37.2%	34.4%	29.0%	22.2%	14.0%
Comments							
Borehole / Test Pit No.	BH12	BH12					
Sample	SS10	SS11					
Tare No.	CS	EE					
Mass Tare Container	9.3	8.7					
Mass Sample (Wet+Tare) (g)	118.2	174					
Mass Sample (Dry+Tare) (g)	101.9	149					
Mass of Water (g)	16.30	25.00					
Mass Dry Sample (g)	92.60	140.30					
Moisture Content (%)	17.6%	17.8%					
Comments							
Borehole / Test Pit No.	BH5	BH5	BH5	BH5	BH5	BH5	BH5
Sample	BS1	SS2	BS3	SS4	BS5	BS6	SS7
Tare No.	ZZ3	EM	SO	CS	IB	15A	CA
Mass Tare Container	8.4	8.5	8.6	8.6	8.5	9.4	9.1
Mass Sample (Wet+Tare) (g)	94.3	114.3	124.1	183.1	125.5	119.4	84.6
Mass Sample (Dry+Tare) (g)	84.5	103.8	99	149.3	117.1	107.6	79.6
Mass of Water (g)	9.80	10.50	25.10	33.80	8.40	11.80	5.00
Mass Dry Sample (g)	76.10	95.30	90.40	140.70	108.60	98.20	70.50
Moisture Content (%)	12.9%	11.0%	27.8%	24.0%	7.7%	12.0%	7.1%
Comments							
Borehole / Test Pit No.	BH5	BH5	BH5	BH5	BH5	BH5	BH5
Sample	BS8	BS9	SS10	BS11	BS12	SS13	BS14
Tare No.	D23	D21	DJ	4A	CR	RJ	114
Mass Tare Container	8.4	8.6	9	9.3	9.3	8.6	8.8
Mass Sample (Wet+Tare) (g)	138.9	93.9	105.9	121.9	149.3	45.1	105.5
Mass Sample (Dry+Tare) (g)	126.5	79.7	104.3	118.9	135.2	39.5	87.8
Mass of Water (g)	12.40	14.20	1.60	3.00	14.10	5.60	17.70
Mass Dry Sample (g)	118.10	71.10	95.30	109.60	125.90	30.90	79.00
Moisture Content (%)	10.5%	20.0%	1.7%	2.7%	11.2%	18.1%	22.4%
Comments							

Reviewed By: 

Reporting of these test results constitutes a testing service only. Engineering interpretation or evaluation of the test results is provided only on written request. The data presented above is for the sole use of the client stipulated above. Stantec is not responsible, nor can be held liable, for the use of this report by any other party, with or without the knowledge of Stantec.



Moisture Content of Soil or Aggregate
CSA A23.2-11A
ASTM D2216

OFFICE
 10160 - 112 ST
 Edmonton, Alberta
 Canada T5K 2L6

LABORATORY
 10575 106 ST
 Edmonton, Alberta
 Canada T5H 2X5

Tel: (780) 917-7000

Tel: (780) 917-7463

Project:	Aurum Road Creek Crossing	Date Tested:	14-Sep-16
Client:	Aurum Industrial Development Partnersh	Tested By:	JA
Project No.:	123312651		

Moisture Content Worksheet							
Borehole / Test Pit No.	BH13	BH13	BH13	BH13	BH13	BH13	BH13
Sample	BS1	SS2	BS3	SS5	SS6	SS7	BS8
Tare No.	ZZ3	EM	SO	CS	18	15A	CA
Mass Tare Container	8.4	8.5	8.6	8.6	8.4	9.4	9.1
Mass Sample (Wet+Tare) (g)	110.9	111.6	199	108.2	150.5	132.8	138.7
Mass Sample (Dry+Tare) (g)	89.5	92.2	152.9	84.2	111.6	103.9	108.9
Mass of Water (g)	21.40	19.40	46.10	24.00	38.90	28.90	29.80
Mass Dry Sample (g)	81.10	83.70	144.30	75.60	103.20	94.50	99.80
Moisture Content (%)	26.4%	23.2%	31.9%	31.7%	37.7%	30.6%	29.9%
Comments							
Borehole / Test Pit No.	BH13	BH13	BH13	BH13	BH13		
Sample	SS9	SS10	SS11	SS12	SS13		
Tare No.	D23	D21	96	CY	3		
Mass Tare Container	8.4	8.6	8.5	8.5	8.7		
Mass Sample (Wet+Tare) (g)	135.9	109.4	179.8	121.2	138.8		
Mass Sample (Dry+Tare) (g)	113.3	92.4	152.8	96.2	116.8		
Mass of Water (g)	22.60	17.00	27.00	25.00	22.00		
Mass Dry Sample (g)	104.90	83.80	144.30	87.70	108.10		
Moisture Content (%)	21.5%	20.3%	18.7%	28.5%	20.4%		
Comments							
Borehole / Test Pit No.							
Sample							
Tare No.							
Mass Tare Container							
Mass Sample (Wet+Tare) (g)							
Mass Sample (Dry+Tare) (g)							
Mass of Water (g)							
Mass Dry Sample (g)							
Moisture Content (%)							
Comments							
Borehole / Test Pit No.							
Sample							
Tare No.							
Mass Tare Container							
Mass Sample (Wet+Tare) (g)							
Mass Sample (Dry+Tare) (g)							
Mass of Water (g)							
Mass Dry Sample (g)							
Moisture Content (%)							
Comments							

Reviewed By:

Reporting of these test results constitutes a testing service only. Engineering interpretation or evaluation of the test results is provided only on written request. The data presented above is for the sole use of the client stipulated above. Stantec is not responsible, nor can be held liable, for the use of this report by any other party, with or without the knowledge of Stantec.



Moisture Content of Soil or Aggregate
CSA A23.2-11A
ASTM D2216

OFFICE
 10160 - 112 ST
 Edmonton, Alberta
 Canada T5K 2L6

LABORATORY
 10575 106 ST
 Edmonton, Alberta
 Canada T5H 2X5

Tel: (780) 917-7000

Tel: (780) 917-7463

Project: Aurum Road Creek Crossing Date Tested: 22-Sep-16
 Client: Aurum Industrial Development Partnersh
 Project No.: 123312651 Tested By: JA

Moisture Content Worksheet							
Borehole / Test Pit No.	BH14	BH14	BH14	BH14	BH14	BH14	
Sample	BS1	SS2	BS3	SS4	BS5	SS6	
Tare No.	8	IGGY	D19	D9	CY	EW	
Mass Tare Container	8.7	8.4	8.6	8.5	8.6	8.7	
Mass Sample (Wet+Tare) (g)	127.1	73.8	186.8	122.3	241.2	125.1	
Mass Sample (Dry+Tare) (g)	94.6	62	146.1	96.1	211.5	110.1	
Mass of Water (g)	32.50	11.80	40.70	26.20	29.70	15.00	
Mass Dry Sample (g)	85.90	53.60	137.50	87.60	202.90	101.40	
Moisture Content (%)	37.8%	22.0%	29.6%	29.9%	14.6%	14.8%	
Comments							
Borehole / Test Pit No.	BH15	BH15	BH15	BH15	BH15	BH15	BH15
Sample	BS1	SS2	BS3	SS4	BS5	SS7A	SS7B
Tare No.	DB	CH	D13	ZZ1	9	CM	D5
Mass Tare Container	8.6	9.2	8.5	8.5	8.6	8.6	8.7
Mass Sample (Wet+Tare) (g)	143.6	92	170.3	124.3	127.7	69.1	88.4
Mass Sample (Dry+Tare) (g)	123.8	79.9	148.3	110	111.2	60.4	58.1
Mass of Water (g)	19.80	12.10	22.00	14.30	16.50	8.70	30.30
Mass Dry Sample (g)	115.20	70.70	139.80	101.50	102.60	51.80	49.40
Moisture Content (%)	17.2%	17.1%	15.7%	14.1%	16.1%	16.8%	61.3%
Comments							
Borehole / Test Pit No.	BH15	BH15	BH15	BH15			
Sample	BS8	SS9	BS10	SS11			
Tare No.	D21	14	2A	D11			
Mass Tare Container	8.6	9.4	9.2	8.5			
Mass Sample (Wet+Tare) (g)	125.7	100.1	146.6	111.8			
Mass Sample (Dry+Tare) (g)	98.2	78.9	107.8	88			
Mass of Water (g)	27.50	21.20	38.80	23.80			
Mass Dry Sample (g)	89.60	69.50	98.60	79.50			
Moisture Content (%)	30.7%	30.5%	39.4%	29.9%			
Comments							
Borehole / Test Pit No.							
Sample							
Tare No.							
Mass Tare Container							
Mass Sample (Wet+Tare) (g)							
Mass Sample (Dry+Tare) (g)							
Mass of Water (g)							
Mass Dry Sample (g)							
Moisture Content (%)							
Comments							

Reviewed By:

Reporting of these test results constitutes a testing service only. Engineering interpretation or evaluation of the test results is provided only on written request. The data presented above is for the sole use of the client stipulated above. Stantec is not responsible, nor can be held liable, for the use of this report by any other party, with or without the knowledge of Stantec.



Moisture Content of Soil or Aggregate
CSA A23.2-11A
ASTM D2216

OFFICE
 10160 - 112 ST
 Edmonton, Alberta
 Canada T5K 2L6

LABORATORY
 10575 106 ST
 Edmonton, Alberta
 Canada T5H 2X5

Tel: (780) 917-7000

Tel: (780) 917-7463

Project: Aurum Road Creek Crossing Date Tested: 26-Oct-16
 Client: Aurum Industrial Development Partnersh
 Project No.: 123312651 Tested By: JA

Moisture Content Worksheet							
Borehole / Test Pit No.	BH15	BH15	BH15	BH15	BH15	BH15	BH15
Sample	RC4	RC7	RC10	RC6	RC12	RC3	RC9
Tare No.	10A	D12	EF	28	RD10	ZZ1	MM
Mass Tare Container	9.3	8.7	8.5	9.3	8.6	8.6	9.5
Mass Sample (Wet+Tare) (g)	163.3	125.5	208.1	101.5	131.6	138.7	226.1
Mass Sample (Dry+Tare) (g)	143.4	102	175.6	86.7	117	116.3	199.6
Mass of Water (g)	19.90	23.50	32.50	14.80	14.60	22.40	26.50
Mass Dry Sample (g)	134.10	93.30	167.10	77.40	108.40	107.70	190.10
Moisture Content (%)	14.8%	25.2%	19.4%	19.1%	13.5%	20.8%	13.9%
Comments							
Borehole / Test Pit No.	BH15	BH15	BH15	BH15	BH15		
Sample	RC5	RC8	RC1	RC11	RC2		
Tare No.	D11	TX	D2	D21	IH		
Mass Tare Container	8.4	8.7	8.6	8.5	9.4		
Mass Sample (Wet+Tare) (g)	263	160.7	99	201.1	261.2		
Mass Sample (Dry+Tare) (g)	235.4	137.1	83.1	173.7	224.7		
Mass of Water (g)	27.60	23.60	15.90	27.40	36.50		
Mass Dry Sample (g)	227.00	128.40	74.50	165.20	215.30		
Moisture Content (%)	12.2%	18.4%	21.3%	16.6%	17.0%		
Comments							
Borehole / Test Pit No.							
Sample							
Tare No.							
Mass Tare Container							
Mass Sample (Wet+Tare) (g)							
Mass Sample (Dry+Tare) (g)							
Mass of Water (g)							
Mass Dry Sample (g)							
Moisture Content (%)							
Comments							
Borehole / Test Pit No.							
Sample							
Tare No.							
Mass Tare Container							
Mass Sample (Wet+Tare) (g)							
Mass Sample (Dry+Tare) (g)							
Mass of Water (g)							
Mass Dry Sample (g)							
Moisture Content (%)							
Comments							

Reviewed By: 

Reporting of these test results constitutes a testing service only. Engineering interpretation or evaluation of the test results is provided only on written request. The data presented above is for the sole use of the client stipulated above. Stantec is not responsible, nor can be held liable, for the use of this report by any other party, with or without the knowledge of Stantec.



Moisture Content of Soil or Aggregate
CSA A23.2-11A
ASTM D2216

OFFICE
 10160 - 112 ST
 Edmonton, Alberta
 Canada T5K 2L6

LABORATORY
 10575 106 ST
 Edmonton, Alberta
 Canada T5H 2X5

Tel: (780) 917-7000

Tel: (780) 917-7463

Project: Aurum Road Creek Crossing Date Tested: 22-Sep-16
 Client: Aurum Industrial Development Partnersh
 Project No.: 123312651 Tested By: JA

Moisture Content Worksheet							
Borehole / Test Pit No.	BH16	BH16	BH16	BH16	BH16	BH16	BH16
Sample	BS1	SS2	BS3	SS5	SS6A	SS6B	BS7
Tare No.	D12	DA	DT	DN	6A	16A	DY
Mass Tare Container	8.7	8.5	8.4	9.2	9.2	9.5	8.7
Mass Sample (Wet+Tare) (g)	76.2	102	105	108.4	66.4	95.8	147.4
Mass Sample (Dry+Tare) (g)	65.9	87.3	93.6	99.6	60.5	89.9	141.1
Mass of Water (g)	10.30	14.70	11.40	8.80	5.90	5.90	6.30
Mass Dry Sample (g)	57.20	78.80	85.20	90.40	51.30	80.40	132.40
Moisture Content (%)	18.0%	18.7%	13.4%	9.7%	11.5%	7.3%	4.8%
Comments							
Borehole / Test Pit No.	BH16	BH16	BH16	BH16	BH16	BH16	BH16
Sample	SS8	BS9	SS10	SS11	SS12	BS13	SS14
Tare No.	2	SAM	28A	BF	DA	EX	14A
Mass Tare Container	8.7	9.3	9.4	8.8	8.7	8.8	9.7
Mass Sample (Wet+Tare) (g)	85.3	130.5	80.8	181.7	109.4	167.4	57.6
Mass Sample (Dry+Tare) (g)	79.4	118.5	70.8	162.1	100.3	145.4	49.6
Mass of Water (g)	5.90	12.00	10.00	19.60	9.10	22.00	8.00
Mass Dry Sample (g)	70.70	109.20	61.40	153.30	91.60	136.60	39.90
Moisture Content (%)	8.3%	11.0%	16.3%	12.8%	9.9%	16.1%	20.1%
Comments							
Borehole / Test Pit No.	BH17	BH17	BH17	BH17	BH17	BH17	BH17
Sample	BS1	SS2	BS3	SS4	BS5	SS6	BS7
Tare No.	96	33	ZZZ	1	D5	MM	CZ
Mass Tare Container	8.6	8.3	8.9	8.5	8.6	9.5	8.8
Mass Sample (Wet+Tare) (g)	111.9	103.8	109.2	154.7	122.8	164.5	97.7
Mass Sample (Dry+Tare) (g)	93.6	87.4	96.7	134.8	115.2	137.7	92.9
Mass of Water (g)	18.30	16.40	12.50	19.90	7.60	26.80	4.80
Mass Dry Sample (g)	85.00	79.10	87.80	126.30	106.60	128.20	84.10
Moisture Content (%)	21.5%	20.7%	14.2%	15.8%	7.1%	20.9%	5.7%
Comments							
Borehole / Test Pit No.	BH17	BH17	BH17	BH17	BH17	BH17	BH17
Sample	SS8	BS9	SS10	BS11	SS12	BS13	SS14
Tare No.	TX	D10	D23	CN	12A	DO	J4
Mass Tare Container	8.9	8.6	8.5	8.8	9.3	9.1	9.2
Mass Sample (Wet+Tare) (g)	60	157.5	124.5	124.9	105.9	160.8	105.4
Mass Sample (Dry+Tare) (g)	57	147.9	111.9	101.6	90.1	146	96.2
Mass of Water (g)	3.00	9.60	12.60	23.30	15.80	14.80	9.20
Mass Dry Sample (g)	48.10	139.30	103.40	92.80	80.80	136.90	87.00
Moisture Content (%)	6.2%	6.9%	12.2%	25.1%	19.6%	10.8%	10.6%
Comments							

Reviewed By:

Reporting of these test results constitutes a testing service only. Engineering interpretation or evaluation of the test results is provided only on written request. The data presented above is for the sole use of the client stipulated above. Stantec is not responsible, nor can be held liable, for the use of this report by any other party, with or without the knowledge of Stantec.



Moisture Content of Soil or Aggregate
CSA A23.2-11A
ASTM D2216

OFFICE
 10160 - 112 ST
 Edmonton, Alberta
 Canada T5K 2L6

LABORATORY
 10575 106 ST
 Edmonton, Alberta
 Canada T5H 2X5

Tel: (780) 917-7000

Tel: (780) 917-7463

Project:	Aurum Road Creek Crossing	Date Tested:	22-Sep-16
Client:	Aurum Industrial Development Partnersh	Tested By:	JA
Project No.:	123312651		

Moisture Content Worksheet							
Borehole / Test Pit No.	BH18	BH18	BH18	BH19	BH19	BH19	
Sample	BS1	BS2	BS3	BS1	BS2	BS3	
Tare No.	19	12	EF	CW	FA	DE	
Mass Tare Container	8.6	8.7	8.6	8.5	8.6	8.6	
Mass Sample (Wet+Tare) (g)	94.5	74.4	56.3	61.6	77.6	80.3	
Mass Sample (Dry+Tare) (g)	77.7	58.2	44.4	51.6	63.8	63.2	
Mass of Water (g)	16.80	16.20	11.90	10.00	13.80	17.10	
Mass Dry Sample (g)	69.10	49.50	35.80	43.10	55.20	54.60	
Moisture Content (%)	24.3%	32.7%	33.2%	23.2%	25.0%	31.3%	
Comments							
Borehole / Test Pit No.	BH20	BH20	BH20	BH21	BH21	BH21	
Sample	BS1	BS2	BS3	BS1	BS2	BS3	
Tare No.	ER	34A	CA	Q4	24A	D2	
Mass Tare Container	8.6	8.4	9.1	8.4	9.3	8.5	
Mass Sample (Wet+Tare) (g)	85.8	90.1	90	86.1	84.4	80.7	
Mass Sample (Dry+Tare) (g)	71.1	75.1	74.6	69.8	65.3	63.7	
Mass of Water (g)	14.70	15.00	15.40	16.30	19.10	17.00	
Mass Dry Sample (g)	62.50	66.70	65.50	61.40	56.00	55.20	
Moisture Content (%)	23.5%	22.5%	23.5%	26.5%	34.1%	30.8%	
Comments							
Borehole / Test Pit No.	BH22	BH22	BH22	BH23	BH23	BH23	
Sample	BS1	BS2	BS3	BS1	BS2	BS3	
Tare No.	28	6	17A	ED	J1	29	
Mass Tare Container	9.1	8.6	9.4	8.6	8.9	9.3	
Mass Sample (Wet+Tare) (g)	81.2	80	60.1	103.4	62.6	78.2	
Mass Sample (Dry+Tare) (g)	74	66.5	48.2	88.8	52.4	65.5	
Mass of Water (g)	7.20	13.50	11.90	14.60	10.20	12.70	
Mass Dry Sample (g)	64.90	57.90	38.80	80.20	43.50	56.20	
Moisture Content (%)	11.1%	23.3%	30.7%	18.2%	23.4%	22.6%	
Comments							
Borehole / Test Pit No.	BH24	BH24	BH24				
Sample	BS1	BS2	BS3			S&G	BEDROCK
Tare No.	3A	EI	10A			EI	Q11
Mass Tare Container	9.5	8.7	9.2			8.7	87
Mass Sample (Wet+Tare) (g)	70.4	71.8	103.3			162.2	125.7
Mass Sample (Dry+Tare) (g)	52.1	45.9	79.8			159.9	118.3
Mass of Water (g)	18.30	25.90	23.50			2.30	7.40
Mass Dry Sample (g)	42.60	37.20	70.60			151.20	31.30
Moisture Content (%)	43.0%	69.6%	33.3%			1.5%	23.6%
Comments						S&G NEAR BH9	EXPOSED NEAR BH9

Reviewed By:

Reporting of these test results constitutes a testing service only. Engineering interpretation or evaluation of the test results is provided only on written request. The data presented above is for the sole use of the client stipulated above. Stantec is not responsible, nor can be held liable, for the use of this report by any other party, with or without the knowledge of Stantec.



Atterberg Limits
 ASTM D4318
 Method B- One Point

Client: Aurum Industrial Development Partnership
 Project Name: Aurum Road Creek Crossing
 Project No: 123312651
 Date Received: September 19, 2016
 Date Tested: October 13, 2016
 Tested By: JA

OFFICE
 10160 - 112 ST
 Edmonton, Alberta
 Canada T5K 2L6
 Tel: (780) 917-7000

LABORATORY
 10575 106 ST
 Edmonton, Alberta
 Canada T5H 2X5
 Tel: (780) 917-7463

Sample: BH16 BULK		Sample: BH17 BULK	
LIQUID		LIQUID	
1	2	Trial No.	
30	30	Number of Blows	23 24
38B	15B	Container Number	20B 39B
41.61	40.42	Wt. Sample (wet+tare)(g)	39.02 40.85
33.61	32.79	Wt. Sample (dry+tare)(g)	31.45 32.80
15.59	15.55	Wt. Tare (g)	15.48 15.40
18.0	17.2	Wt. Dry Soil (g)	16.0 17.4
8.0	7.6	Wt. Water (g)	7.6 8.1
44.4%	44.3%	Water Content (%)	47.4% 46.3%
45.4%	45.2%	Corrected Water Content (%)	46.9% 46.0%
PLASTIC		PLASTIC	
1	2	Trial No.	
AK	AN	Container Number	BA AF
20.48	20.33	Wt. Sample (wet+tare)(g)	20.38 20.5
19.42	19.27	Wt. Sample (dry+tare)(g)	19.28 19.51
14.26	14.11	Wt. Tare (g)	13.3 14.07
5.2	5.2	Wt. Dry Soil (g)	6.0 5.4
1.1	1.1	Wt. Water (g)	1.1 1.0
20.5%	20.5%	Water Content (%)	18.4% 18.2%
AVERAGE VALUES		AVERAGE VALUES	
1	2	1	2
LL	45	LL	46
PL	21	PL	18
PI	24	PI	28
CLASSIFICATION		CLASSIFICATION	

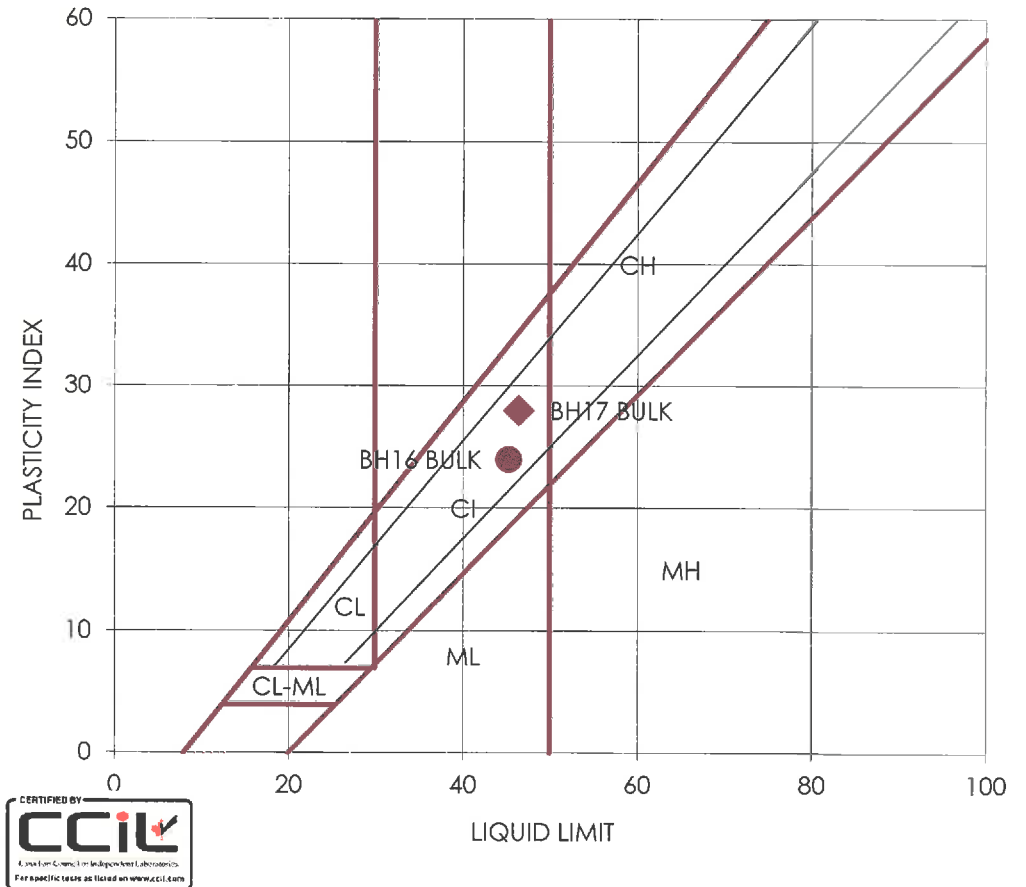

Reporting of these test results constitutes a testing service only. Engineering interpretation or evaluation of the test results is provided only on written request. The data presented above is for the sole use of the client stipulated above. STANTEC is not responsible, nor can be held liable, for the use of this report by any other party, with or without the knowledge of STANTEC.

Reviewed By:



Atterberg Limits
 ASTM D4318
 Method B- One Point

Client: Aurum Industrial Development Partnership
 Project Name: Aurum Road Creek Crossing
 Project No: 123312651
 Date Received: September 19, 2016
 Date Tested: November 7, 2016
 Tested By: JA

OFFICE
 10160 - 112 ST
 Edmonton, Alberta
 Canada T5K 2L6
 Tel: (780) 917-7000

LABORATORY
 10575 106 ST
 Edmonton, Alberta
 Canada T5H 2X5
 Tel: (780) 917-7463

Sample: BH2 RC1 8.1M		Sample: BH2 RC2 9.0M	
LIQUID		LIQUID	
1	2	Trial No.	
20	20	Number of Blows	25 28
45B	23B	Container Number	3B 41B
38.44	38.27	Wt. Sample (wet+tare)(g)	34.56 35.57
31.20	30.98	Wt. Sample (dry+tare)(g)	28.24 28.97
15.71	15.34	Wt. Tare (g)	15.41 15.56
15.5	15.6	Wt. Dry Soil (g)	12.8 13.4
7.2	7.3	Wt. Water (g)	6.3 6.6
46.7%	46.6%	Water Content (%)	49.3% 49.2%
45.5%	45.4%	Corrected Water Content (%)	49.3% 49.9%
PLASTIC		PLASTIC	
1	2	Trial No.	
BF	BC	Container Number	AM AV
20.53	20.78	Wt. Sample (wet+tare)(g)	20.59 20.6
19.58	19.77	Wt. Sample (dry+tare)(g)	19.3 19.35
14.15	14.18	Wt. Tare (g)	13.86 14.14
5.4	5.6	Wt. Dry Soil (g)	5.4 5.2
1.0	1.0	Wt. Water (g)	1.3 1.3
17.5%	18.1%	Water Content (%)	23.7% 24.0%
AVERAGE VALUES		AVERAGE VALUES	
1	2	1	2
LL	45	LL	50
PL	18	PL	24
PI	27	PI	26
CLASSIFICATION		CLASSIFICATION	

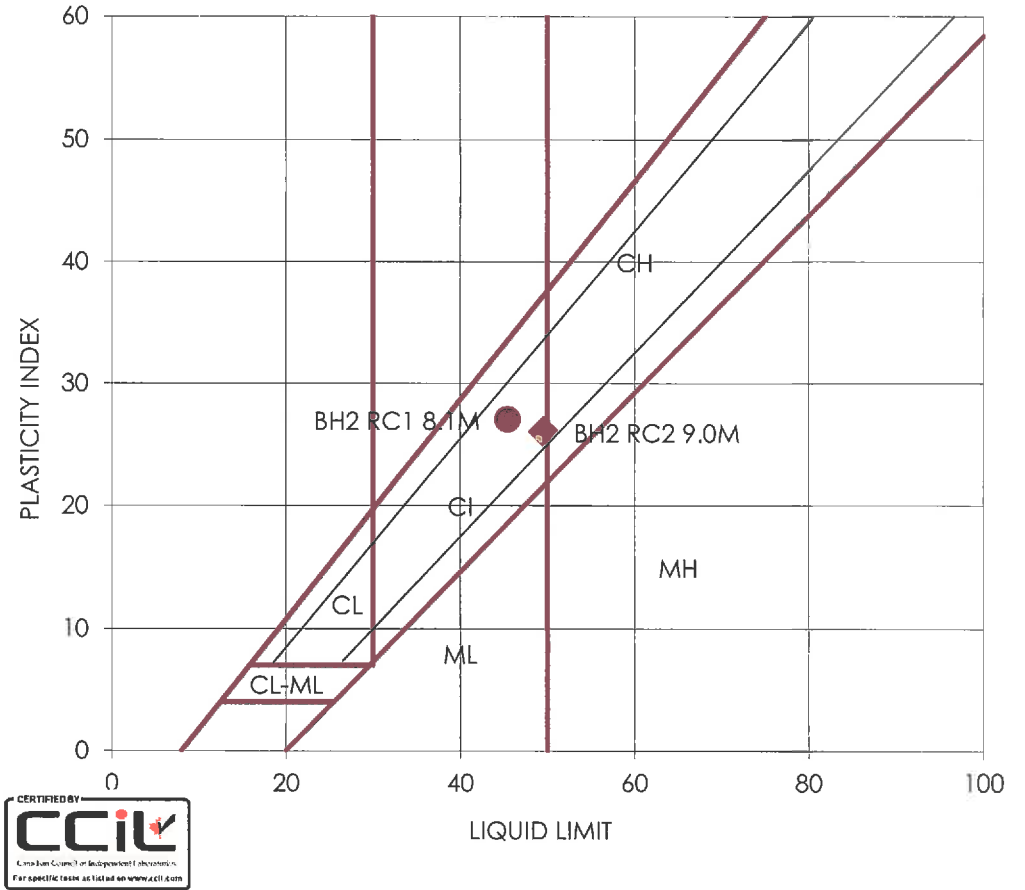

Reporting of these test results constitutes a testing service only. Engineering interpretation or evaluation of the test results is provided only on written request. The data presented above is for the sole use of the client stipulated above. STANTEC is not responsible, nor can be held liable, for the use of this report by any other party, with or without the knowledge of STANTEC.

Reviewed By:



Atterberg Limits
 ASTM D4318
 Method B- One Point

Client: Aurum Industrial Development Partnership 10160 - 112 ST
 Project Name: Aurum Road Creek Crossing
 Project No: 123312651
 Date Received: September 19, 2016
 Date Tested: November 2, 2016
 Tested By: JA

OFFICE
 10160 - 112 ST
 Edmonton, Alberta
 Canada T5K 2L6
 Tel: (780) 917-7000

LABORATORY
 10575 106 ST
 Edmonton, Alberta
 Canada T5H 2X5
 Tel: (780) 917-7463

Sample: BH2 RC4 11.97M		Sample: BH9 SS4	
LIQUID		LIQUID	
1	2	Trial No.	
29	30	Number of Blows	22 25
38B	15B	Container Number	23B 42B
37.37	34.76	Wt. Sample (wet+tare)(g)	35.12 36.41
29.52	27.85	Wt. Sample (dry+tare)(g)	27.72 28.66
15.58	15.56	Wt. Tare (g)	15.24 15.55
13.9	12.3	Wt. Dry Soil (g)	12.5 13.1
7.9	6.9	Wt. Water (g)	7.4 7.8
56.3%	56.2%	Water Content (%)	59.3% 59.1%
57.3%	57.5%	Corrected Water Content (%)	58.4% 59.1%
PLASTIC		PLASTIC	
1	2	Trial No.	
AK	AN	Container Number	BD BN
20.72	20.58	Wt. Sample (wet+tare)(g)	21.63 21.07
19.61	19.44	Wt. Sample (dry+tare)(g)	20.04 19.59
14.25	14.11	Wt. Tare (g)	14.12 14.03
5.4	5.3	Wt. Dry Soil (g)	5.9 5.6
1.1	1.1	Wt. Water (g)	1.6 1.5
20.7%	21.4%	Water Content (%)	26.9% 26.6%
AVERAGE VALUES		AVERAGE VALUES	
1	2	1	2
LL	57	LL	59
PL	21	PL	27
PI	36	PI	32
CLASSIFICATION		CLASSIFICATION	
CH		CH	

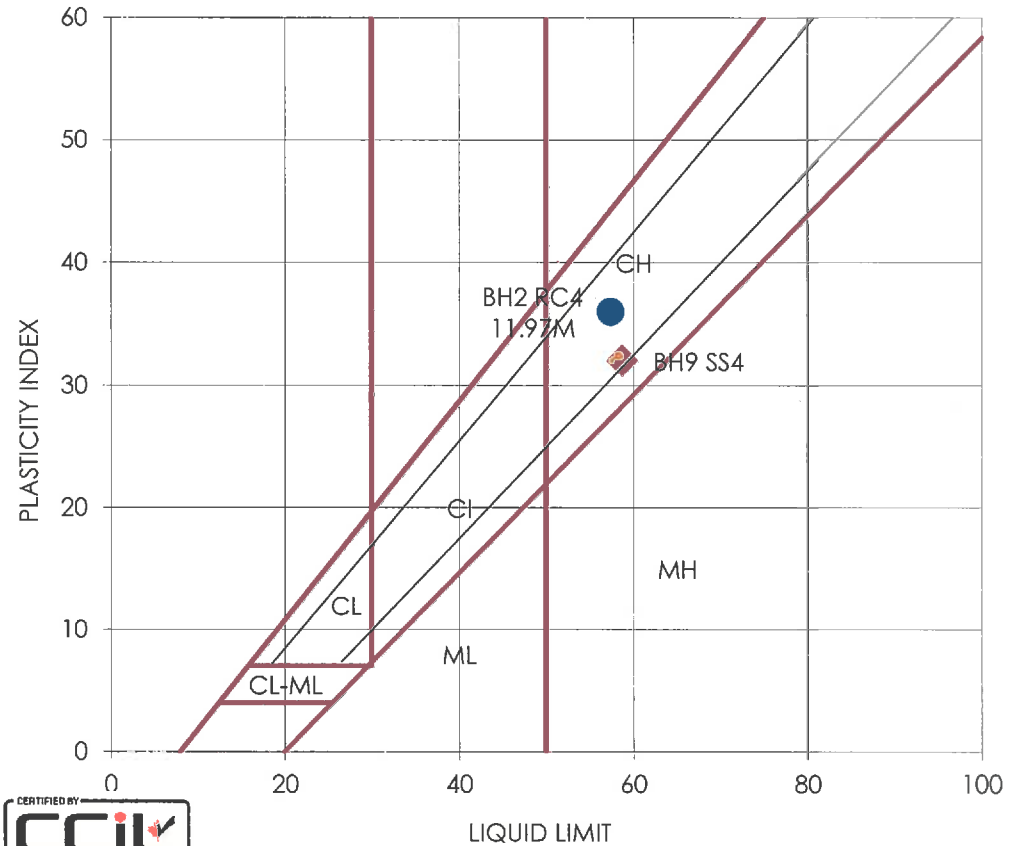

Reporting of these test results constitutes a testing service only. Engineering interpretation or evaluation of the test results is provided only on written request. The data presented above is for the sole use of the client stipulated above. STANTEC is not responsible, nor can be held liable, for the use of this report by any other party, with or without the knowledge of STANTEC.

Reviewed By:



Atterberg Limits
 ASTM D4318
 Method B- One Point

Client: Aurum Industrial Development Partnership
 Project Name: Aurum Road Creek Crossing
 Project No: 123312651
 Date Received: September 19, 2016
 Date Tested: October 13, 2016
 Tested By: JA

OFFICE
 10160 - 112 ST
 Edmonton, Alberta
 Canada T5K 2L6
 Tel: (780) 917-7000

LABORATORY
 10575 106 ST
 Edmonton, Alberta
 Canada T5H 2X5
 Tel: (780) 917-7463

Sample: BH2 SS15		Sample: BH3 BS4	
LIQUID		LIQUID	
1	2	Trial No.	
29	30	Number of Blows	23 26
43B	32B	Container Number	10B 36B
48.22	41.45	Wt. Sample (wet+tare)(g)	39.42 38.94
40.34	34.83	Wt. Sample (dry+tare)(g)	31.10 30.80
15.35	15.14	Wt. Tare (g)	15.41 15.39
25.0	19.7	Wt. Dry Soil (g)	15.7 15.4
7.9	6.6	Wt. Water (g)	8.3 8.1
31.5%	33.6%	Water Content (%)	53.0% 52.8%
32.1%	34.4%	Corrected Water Content (%)	52.5% 53.1%
PLASTIC		PLASTIC	
1	2	Trial No.	
AB	AC	Container Number	AD BU
20.5	20.83	Wt. Sample (wet+tare)(g)	20.44 20.67
19.41	19.75	Wt. Sample (dry+tare)(g)	19.09 19.23
13.94	14.28	Wt. Tare (g)	14.15 14
5.5	5.5	Wt. Dry Soil (g)	4.9 5.2
1.1	1.1	Wt. Water (g)	1.4 1.4
19.9%	19.7%	Water Content (%)	27.3% 27.5%
AVERAGE VALUES		AVERAGE VALUES	
1	2	1	2
LL	33	LL	53
PL	20	PL	27
PI	13	PI	26
CLASSIFICATION		CLASSIFICATION	
CI		CH	

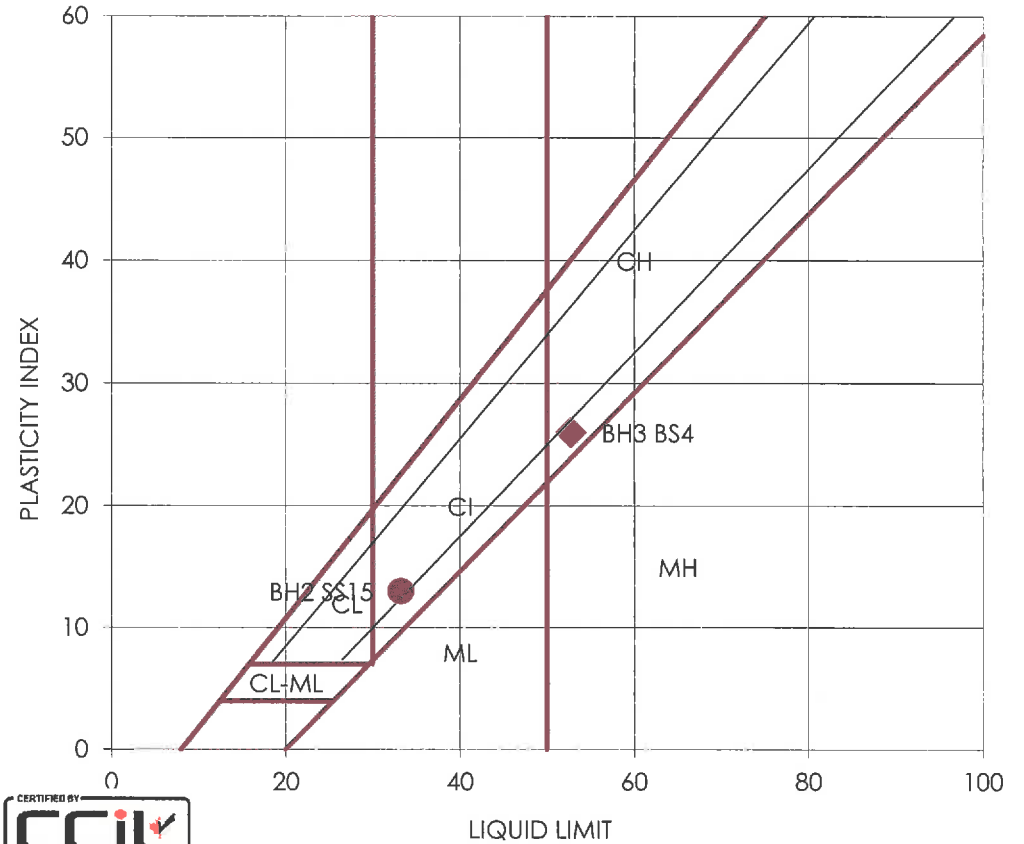

Reporting of these test results constitutes a testing service only. Engineering interpretation or evaluation of the test results is provided only on written request. The data presented above is for the sole use of the client stipulated above. STANTEC is not responsible, nor can be held liable, for the use of this report by any other party, with or without the knowledge of STANTEC.

Reviewed By: [Signature]



Atterberg Limits
 ASTM D4318
 Method B- One Point

Client: Aurum Industrial Development Partnership
 Project Name: Aurum Road Creek Crossing
 Project No: 123312651
 Date Received: September 19, 2016
 Date Tested: November 1, 2016
 Tested By: JA

OFFICE
 10160 - 112 ST
 Edmonton, Alberta
 Canada T5K 2L6
 Tel: (780) 917-7000

LABORATORY
 10575 106 ST
 Edmonton, Alberta
 Canada T5H 2X5
 Tel: (780) 917-7463

Sample: BH3 RC1 - 6.0M		Sample: BH4 RC5 12.75M	
LIQUID		LIQUID	
1	2	Trial No.	
30	30	Number of Blows	21 22
9B	AH	Container Number	16B 27B
34.90	35.08	Wt. Sample (wet+tare)(g)	37.33 38.83
28.65	28.30	Wt. Sample (dry+tare)(g)	31.37 32.45
15.61	14.06	Wt. Tare (g)	15.57 15.42
13.0	14.2	Wt. Dry Soil (g)	15.8 17.0
6.3	6.8	Wt. Water (g)	6.0 6.4
47.9%	47.6%	Water Content (%)	37.7% 37.5%
49.0%	48.7%	Corrected Water Content (%)	36.9% 36.9%
PLASTIC		PLASTIC	
1	2	Trial No.	
AE	AI	Container Number	AZ BU
20.22	20.41	Wt. Sample (wet+tare)(g)	21.02 21.06
18.98	19.12	Wt. Sample (dry+tare)(g)	20.2 20.24
14.11	14.09	Wt. Tare (g)	13.93 14.16
4.9	5.0	Wt. Dry Soil (g)	6.3 6.1
1.2	1.3	Wt. Water (g)	0.8 0.8
25.5%	25.6%	Water Content (%)	13.1% 13.5%
AVERAGE VALUES		AVERAGE VALUES	
1	2	1	2
LL	49	LL	37
PL	26	PL	13
PI	23	PI	24
CLASSIFICATION		CLASSIFICATION	
CI-CH		CI	

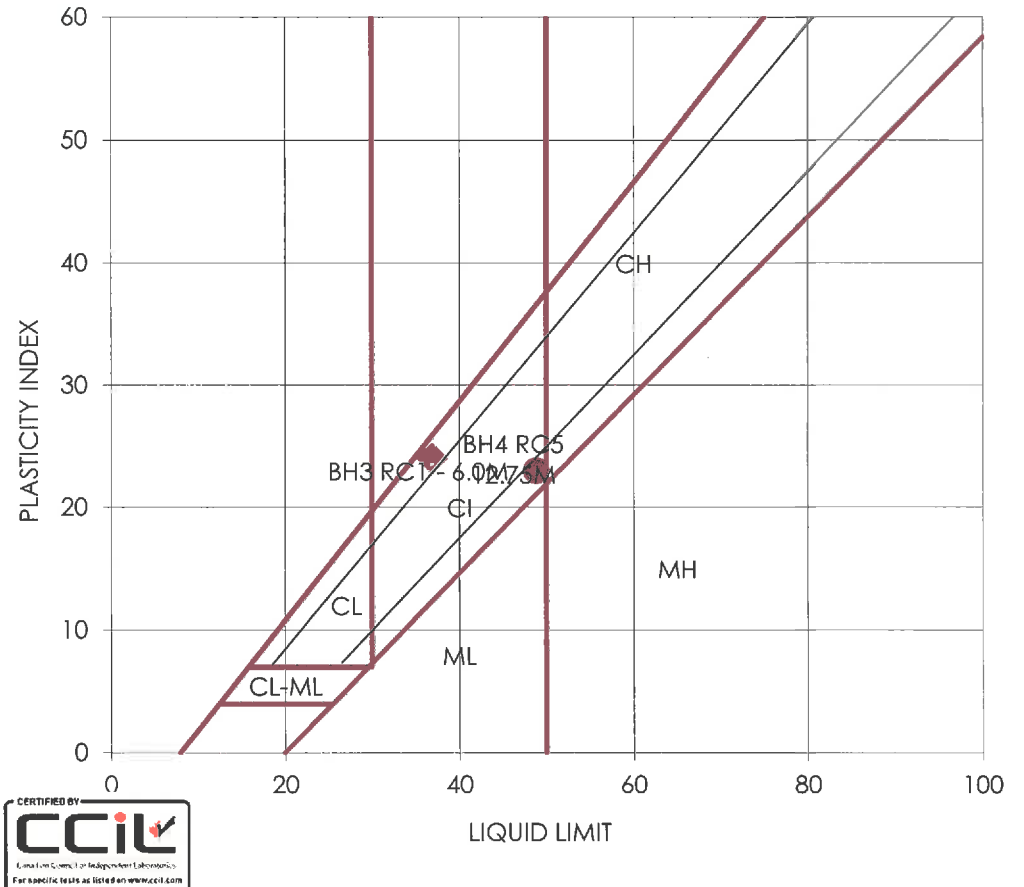

Reporting of these test results constitutes a testing service only. Engineering interpretation or evaluation of the test results is provided only on written request. The data presented above is for the sole use of the client stipulated above. STANTEC is not responsible, nor can be held liable, for the use of this report by any other party, with or without the knowledge of STANTEC.

Reviewed By: [Signature]



Atterberg Limits
 ASTM D4318
 Method B- One Point

Client: Aurum Industrial Development Partnership
 Project Name: Aurum Road Creek Crossing
 Project No: 123312651
 Date Received: September 19, 2016
 Date Tested: November 7, 2016
 Tested By: JA

OFFICE
 10160 - 112 ST
 Edmonton, Alberta
 Canada T5K 2L6
 Tel: (780) 917-7000

LABORATORY
 10575 106 ST
 Edmonton, Alberta
 Canada T5H 2X5
 Tel: (780) 917-7463

Sample: BH3 RC4 10.5M		Sample: BH11 RC4 13.5M	
LIQUID		LIQUID	
1	2	Trial No.	
25	27	Number of Blows	27 30
27B	16B	Container Number	37B 22B
34.93	34.23	Wt. Sample (wet+tare)(g)	35.68 35.98
28.48	28.07	Wt. Sample (dry+tare)(g)	28.87 29.18
15.43	15.59	Wt. Tare (g)	15.26 15.55
13.1	12.5	Wt. Dry Soil (g)	13.6 13.6
6.5	6.2	Wt. Water (g)	6.8 6.8
49.4%	49.4%	Water Content (%)	50.0% 49.9%
49.4%	49.8%	Corrected Water Content (%)	50.5% 51.0%
PLASTIC		PLASTIC	
1	2	Trial No.	
AE	A1	Container Number	AS AW
20.48	20.82	Wt. Sample (wet+tare)(g)	20.57 20.78
19.34	19.62	Wt. Sample (dry+tare)(g)	19.19 19.42
14.11	14.1	Wt. Tare (g)	14.12 14.25
5.2	5.5	Wt. Dry Soil (g)	5.1 5.2
1.1	1.2	Wt. Water (g)	1.4 1.4
21.8%	21.7%	Water Content (%)	27.2% 26.3%
AVERAGE VALUES		AVERAGE VALUES	
1	2	1	2
LL	50	LL	51
PL	22	PL	27
PI	28	PI	24
CLASSIFICATION		CLASSIFICATION	
CI-CH		CH-CI	

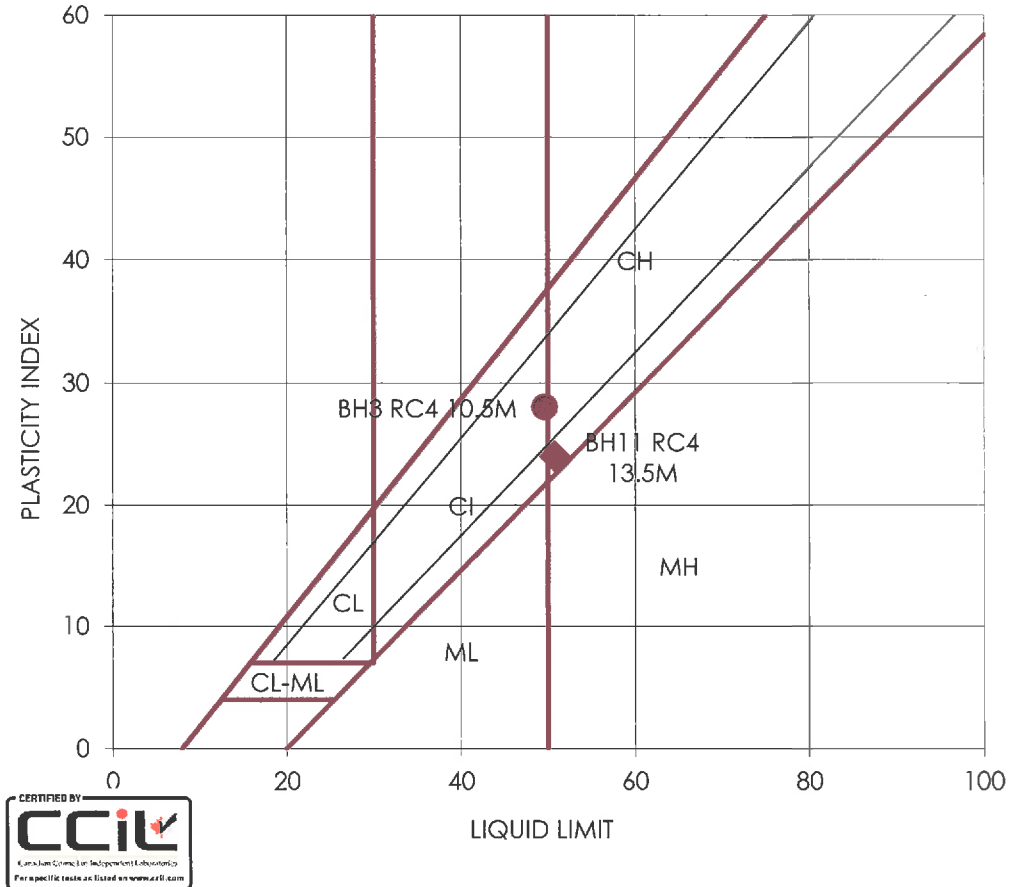

Reporting of these test results constitutes a testing service only. Engineering interpretation or evaluation of the test results is provided only on written request. The data presented above is for the sole use of the client stipulated above. STANTEC is not responsible, nor can be held liable, for the use of this report by any other party, with or without the knowledge of STANTEC.

Reviewed By:



Atterberg Limits
 ASTM D4318
 Method B- One Point

Client: Aurum Industrial Development Partnership
 Project Name: Aurum Road Creek Crossing
 Project No: 123312651
 Date Received: September 19, 2016
 Date Tested: October 13, 2016
 Tested By: JA

OFFICE
 10160 - 112 ST
 Edmonton, Alberta
 Canada T5K 2L6
 Tel: (780) 917-7000

LABORATORY
 10575 106 ST
 Edmonton, Alberta
 Canada T5H 2X5
 Tel: (780) 917-7463

Sample: BH5 BS3		Sample: BH6 BS4	
LIQUID		LIQUID	
1	2	Trial No.	
29	30	Number of Blows	23 25
8B	35B	Container Number	5B 2B
37.12	37.56	Wt. Sample (wet+tare)(g)	35.96 38.08
28.18	28.58	Wt. Sample (dry+tare)(g)	30.32 31.85
15.36	15.67	Wt. Tare (g)	15.41 15.31
12.8	12.9	Wt. Dry Soil (g)	14.9 16.5
8.9	9.0	Wt. Water (g)	5.6 6.2
69.7%	69.6%	Water Content (%)	37.8% 37.7%
71.0%	71.1%	Corrected Water Content (%)	37.4% 37.7%
PLASTIC		PLASTIC	
1	2	Trial No.	
BB	BG	Container Number	AU AM
20.38	20.84	Wt. Sample (wet+tare)(g)	20.27 20.53
18.69	19.16	Wt. Sample (dry+tare)(g)	19.32 19.57
14.2	14.68	Wt. Tare (g)	14.05 14.01
4.5	4.5	Wt. Dry Soil (g)	5.3 5.6
1.7	1.7	Wt. Water (g)	0.9 1.0
37.6%	37.5%	Water Content (%)	18.0% 17.3%
AVERAGE VALUES		AVERAGE VALUES	
1	2	1	2
LL	71	LL	38
PL	38	PL	18
PI	33	PI	20
CLASSIFICATION		CLASSIFICATION	
MH		CI	

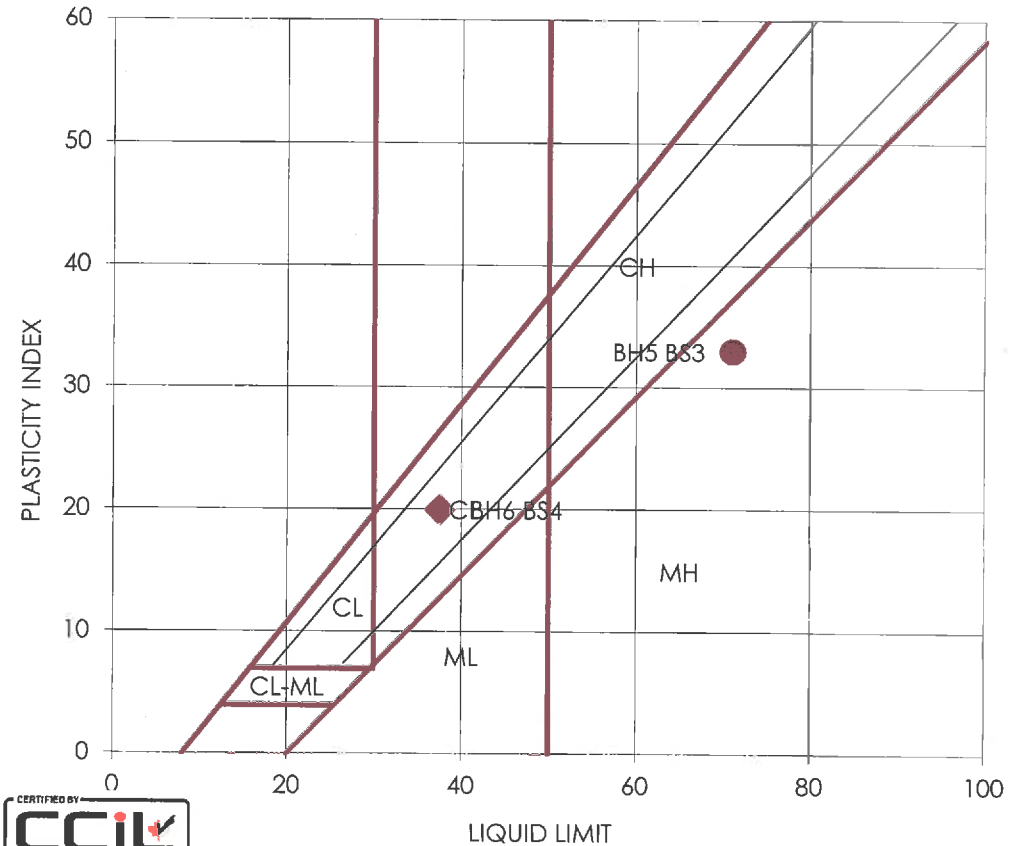

Reporting of these test results constitutes a testing service only. Engineering interpretation or evaluation of the test results is provided only on written request. The data presented above is for the sole use of the client stipulated above. STANTEC is not responsible, nor can be held liable, for the use of this report by any other party, with or without the knowledge of STANTEC.

Reviewed By: [Signature]



Atterberg Limits
 ASTM D4318
 Method B- One Point

Client: Aurum Industrial Development Partnership
 Project Name: Aurum Road Creek Crossing
 Project No: 123312651
 Date Received: September 19, 2016
 Date Tested: November 2, 2016
 Tested By: JA

OFFICE
 10160 - 112 ST
 Edmonton, Alberta
 Canada T5K 2L6
 Tel: (780) 917-7000

LABORATORY
 10575 106 ST
 Edmonton, Alberta
 Canada T5H 2X5
 Tel: (780) 917-7463

Sample:		Sample:	
BH6 RC9 - 24.7M		BH10 RC6 - 12.3M	
LIQUID		LIQUID	
1	2	Trial No.	
28	29	Number of Blows	21 23
26B	12B	Container Number	23B 46B
36.25	36.42	Wt. Sample (wet+tare)(g)	33.20 35.95
29.30	29.26	Wt. Sample (dry+tare)(g)	26.81 28.58
15.53	15.04	Wt. Tare (g)	15.31 15.29
13.8	14.2	Wt. Dry Soil (g)	11.5 13.3
7.0	7.2	Wt. Water (g)	6.4 7.4
50.5%	50.4%	Water Content (%)	55.6% 55.5%
51.2%	51.3%	Corrected Water Content (%)	54.4% 54.9%
PLASTIC		PLASTIC	
1	2	Trial No.	
BJ	BK	Container Number	BC BF
20.24	20.87	Wt. Sample (wet+tare)(g)	20.64 20.7
19.24	19.82	Wt. Sample (dry+tare)(g)	19.41 19.42
13.97	14.3	Wt. Tare (g)	14.18 14.14
5.3	5.5	Wt. Dry Soil (g)	5.2 5.3
1.0	1.1	Wt. Water (g)	1.2 1.3
19.0%	19.0%	Water Content (%)	23.5% 24.2%
AVERAGE VALUES		AVERAGE VALUES	
1	2	1	2
LL	51	LL	55
PL	19	PL	24
PI	32	PI	31
CLASSIFICATION		CLASSIFICATION	
CH-CI		CH	

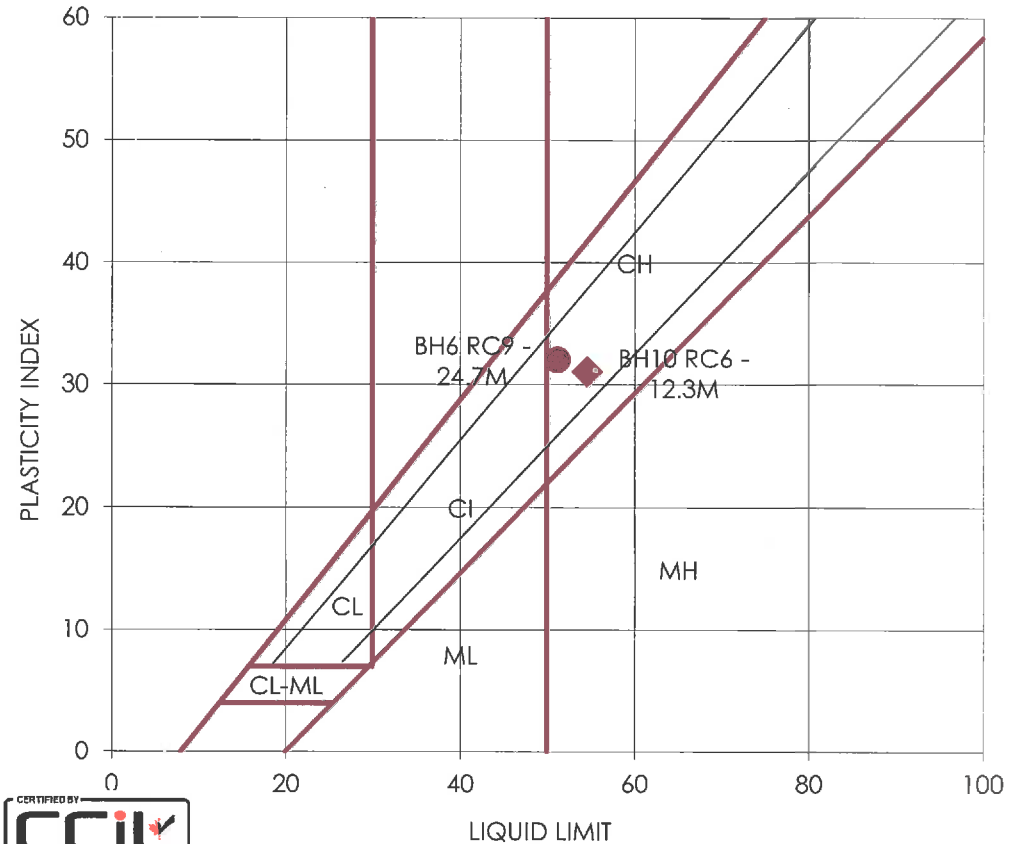

Reporting of these test results constitutes a testing service only. Engineering interpretation or evaluation of the test results is provided only on written request. The data presented above is for the sole use of the client stipulated above. STANTEC is not responsible, nor can be held liable, for the use of this report by any other party, with or without the knowledge of STANTEC.

Reviewed By: _____



Atterberg Limits
 ASTM D4318
 Method B- One Point

Client: Aurum Industrial Dev. Partnership
 Project Name: Aurum Road Creek Crossing
 Project No: 123312651
 Date Received: October 28, 2016
 Date Tested: November 10, 2016
 Tested By: C. Woods

OFFICE

325 - 25th Street SE
 Suite 200
 Calgary, Alberta
 Canada T2A 7H8
 Tel: (403) 716-8000

LABORATORY

10830 - 46th Street SE
 Calgary, Alberta
 Canada T2C 1G4
 Tel: (403) 253-7876

Sample:		Sample:	
BH08 RC4		LIQUID	
LIQUID		LIQUID	
1	2	Trial No.	1
26	26	Number of Blows	2
		Container Number	
22.42	23.01	Wt. Sample (wet+tare) (g)	
14.78	15.19	Wt. Sample (dry+tare) (g)	
1.26	1.33	Wt. Tare (g)	
13.5	13.9	Wt. Dry Soil (g)	
7.6	7.8	Wt. Water (g)	
56.5%	56.4%	Water Content (%)	
56.8%	56.7%	Corrected Water Content (%)	
PLASTIC		PLASTIC	
1	2	Trial No.	1
		Container Number	2
24.64	22.38	Wt. Sample (wet+tare) (g)	
22.51	20.69	Wt. Sample (dry+tare) (g)	
13.92	13.81	Wt. Tare (g)	
8.6	6.9	Wt. Dry Soil (g)	
2.1	1.7	Wt. Water (g)	
24.8%	24.6%	Water Content (%)	
AVERAGE VALUES		AVERAGE VALUES	
1	2	1	2
LL	57	LL	
PL	25	PL	
PI	32	PI	
CLASSIFICATION		CLASSIFICATION	
CH		NON-PLASTIC	

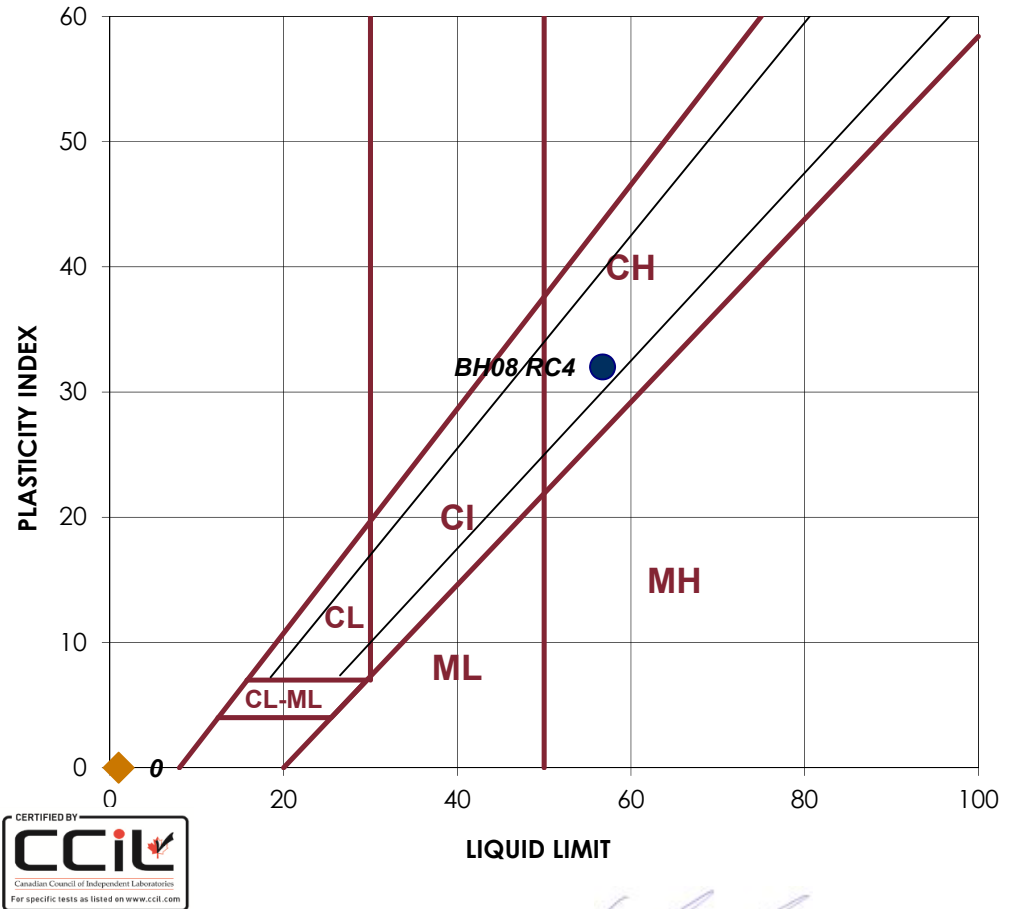

Reporting of these test results constitutes a testing service only. Engineering interpretation or evaluation of the test results is provided only on written request. The data presented above is for the sole use of the client stipulated above. STANTEC is not responsible, nor can be held liable, for the use of this report by any other party, with or without the knowledge of STANTEC.

Reviewed By: _____





Atterberg Limits
 ASTM D4318
 Method B- One Point

Client: Aurum Industrial Development Partnership
 Project Name: Aurum Road Creek Crossing
 Project No: 123312651
 Date Received: September 19, 2016
 Date Tested: November 2, 2016
 Tested By: JA

OFFICE
 10160 - 112 ST
 Edmonton, Alberta
 Canada T5K 2L6
 Tel: (780) 917-7000

LABORATORY
 10575 106 ST
 Edmonton, Alberta
 Canada T5H 2X5
 Tel: (780) 917-7463

Sample:		Sample:	
BH9 RC2 - 5.76M		BH9 RC9 - 17.11M	
LIQUID		LIQUID	
1	2	Trial No.	
20	23	Number of Blows	21
47B	30B	Container Number	40B
36.76	36.47	Wt. Sample (wet+tare)(g)	34.58
30.03	29.72	Wt. Sample (dry+tare)(g)	26.24
15.60	15.24	Wt. Tare (g)	15.27
14.4	14.5	Wt. Dry Soil (g)	11.0
6.7	6.8	Wt. Water (g)	8.3
46.6%	46.6%	Water Content (%)	76.0%
45.4%	46.1%	Corrected Water Content (%)	74.4%
PLASTIC		PLASTIC	
1	2	Trial No.	
BL	AP	Container Number	AR
20.84	20.94	Wt. Sample (wet+tare)(g)	20.76
19.69	19.75	Wt. Sample (dry+tare)(g)	19.24
14.21	14.2	Wt. Tare (g)	14.11
5.5	5.6	Wt. Dry Soil (g)	5.1
1.2	1.2	Wt. Water (g)	1.5
21.0%	21.4%	Water Content (%)	29.6%
AVERAGE VALUES		AVERAGE VALUES	
1	2	1	2
LL	46	LL	74
PL	21	PL	30
PI	25	PI	44
CLASSIFICATION		CLASSIFICATION	
CI		CH	

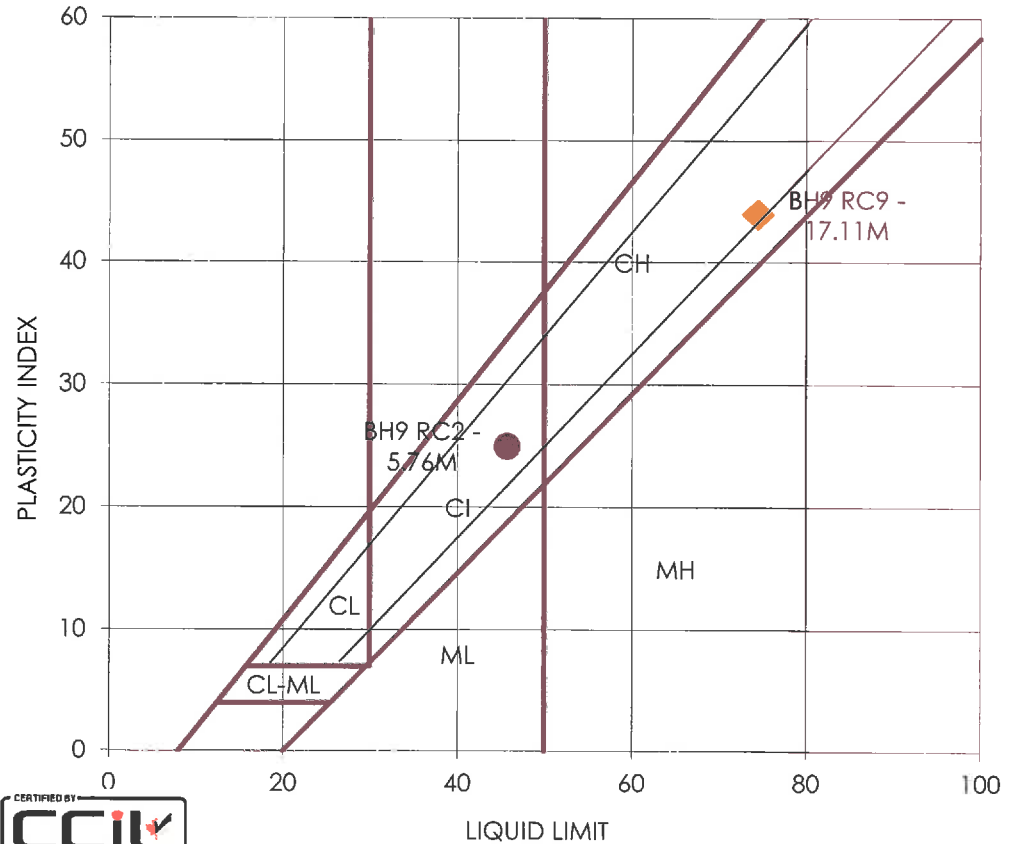

Reporting of these test results constitutes a testing service only. Engineering interpretation or evaluation of the test results is provided only on written request. The data presented above is for the sole use of the client stipulated above. STANTEC is not responsible, nor can be held liable, for the use of this report by any other party, with or without the knowledge of STANTEC.

Reviewed By: *[Signature]*



Atterberg Limits
 ASTM D4318
 Method B- One Point

Client: Aurum Industrial Development Partnership
 Project Name: Aurum Road Creek Crossing
 Project No: 123312651
 Date Received: September 19, 2016
 Date Tested: October 13, 2016
 Tested By: JA

OFFICE
 10160 - 112 ST
 Edmonton, Alberta
 Canada T5K 2L6
 Tel: (780) 917-7000

LABORATORY
 10575 106 ST
 Edmonton, Alberta
 Canada T5H 2X5
 Tel: (780) 917-7463

Sample: BH10 SS8		Sample: BH11 BS5	
LIQUID		LIQUID	
1	2	Trial No.	
26	28	Number of Blows	20 20
47B	30B	Container Number	12B 46B
41.37	39.78	Wt. Sample (wet+tare)(g)	33.62 34.96
32.88	31.73	Wt. Sample (dry+tare)(g)	26.91 27.86
15.59	15.23	Wt. Tare (g)	15.03 15.29
17.3	16.5	Wt. Dry Soil (g)	11.9 12.6
8.5	8.1	Wt. Water (g)	6.7 7.1
49.1%	48.8%	Water Content (%)	56.5% 56.5%
49.3%	49.5%	Corrected Water Content (%)	55.0% 55.0%
PLASTIC		PLASTIC	
1	2	Trial No.	
BL	AP	Container Number	BC BH
20.61	20.85	Wt. Sample (wet+tare)(g)	20.3 20.39
19.29	19.49	Wt. Sample (dry+tare)(g)	18.72 18.79
14.2	14.19	Wt. Tare (g)	14.18 14.15
5.1	5.3	Wt. Dry Soil (g)	4.5 4.6
1.3	1.4	Wt. Water (g)	1.6 1.6
25.9%	25.7%	Water Content (%)	34.8% 34.5%
AVERAGE VALUES		AVERAGE VALUES	
1	2	1	2
LL	49	LL	55
PL	26	PL	35
PI	23	PI	20
CLASSIFICATION		CLASSIFICATION	
CI-CH		MH	

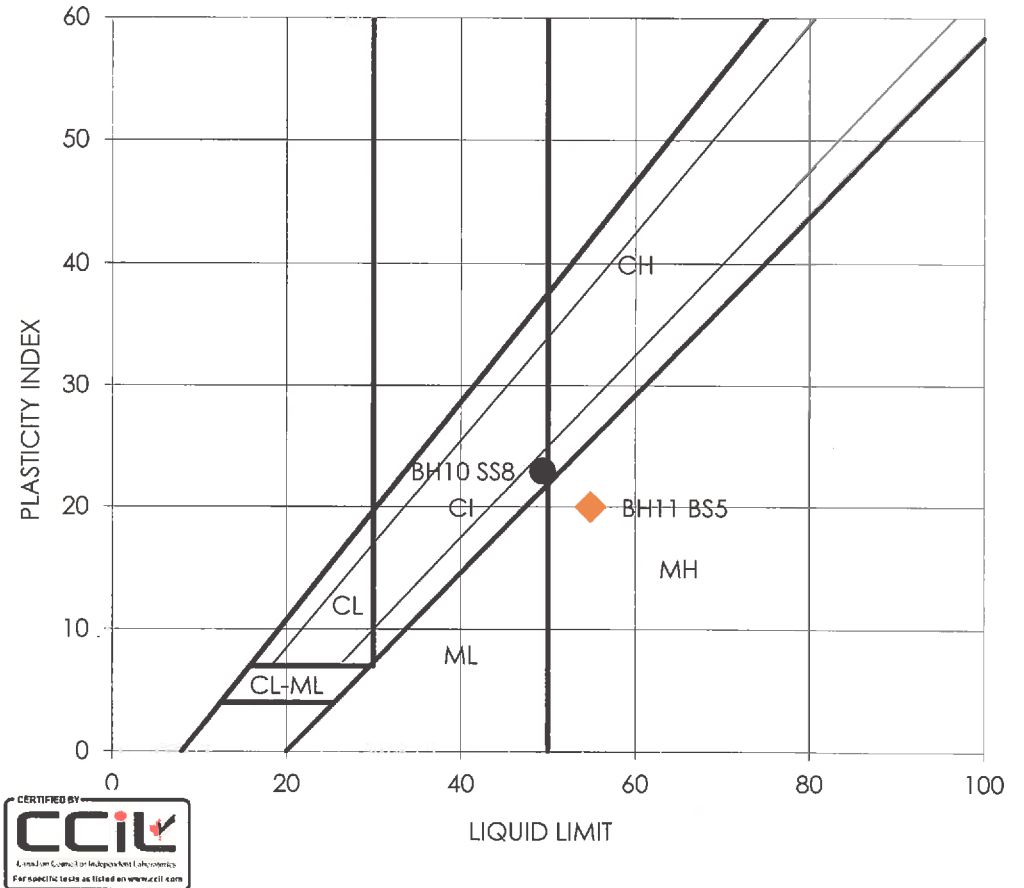

Reporting of these test results constitutes a testing service only. Engineering interpretation or evaluation of the test results is provided only on written request. The data presented above is for the sole use of the client stipulated above. STANTEC is not responsible, nor can be held liable, for the use of this report by any other party, with or without the knowledge of STANTEC.

Reviewed By: *[Signature]*



Atterberg Limits
 ASTM D4318
 Method B- One Point

Client: Aurum Industrial Development Partnership
 Project Name: Aurum Road Creek Crossing
 Project No: 123312651
 Date Received: September 19, 2016
 Date Tested: November 7, 2016
 Tested By: JA

OFFICE
 10160 - 112 ST
 Edmonton, Alberta
 Canada T5K 2L6
 Tel: (780) 917-7000

LABORATORY
 10575 106 ST
 Edmonton, Alberta
 Canada T5H 2X5
 Tel: (780) 917-7463

Sample:		Sample:	
BH12 RC2 5.5M			
LIQUID		LIQUID	
1	2	Trial No.	
21	21	Number of Blows	
9B	AG	Container Number	
37.10	36.65	Wt. Sample (wet+tare)(g)	
29.90	29.14	Wt. Sample (dry+tare)(g)	
15.62	14.09	Wt. Tare (g)	
14.3	15.1	Wt. Dry Soil (g)	
7.2	7.5	Wt. Water (g)	
50.4%	49.9%	Water Content (%)	
49.4%	48.9%	Corrected Water Content (%)	
PLASTIC		PLASTIC	
1	2	Trial No.	
AZ	BV	Container Number	
20.67	20.98	Wt. Sample (wet+tare)(g)	
19.32	19.62	Wt. Sample (dry+tare)(g)	
13.93	14.15	Wt. Tare (g)	
5.4	5.5	Wt. Dry Soil (g)	
1.4	1.4	Wt. Water (g)	
25.0%	24.9%	Water Content (%)	
AVERAGE VALUES		AVERAGE VALUES	
1	2	1	2
LL	49	LL	
PL	25	PL	
PI	24	PI	
CLASSIFICATION		CLASSIFICATION	
CI-CH		NON-PLASTIC	

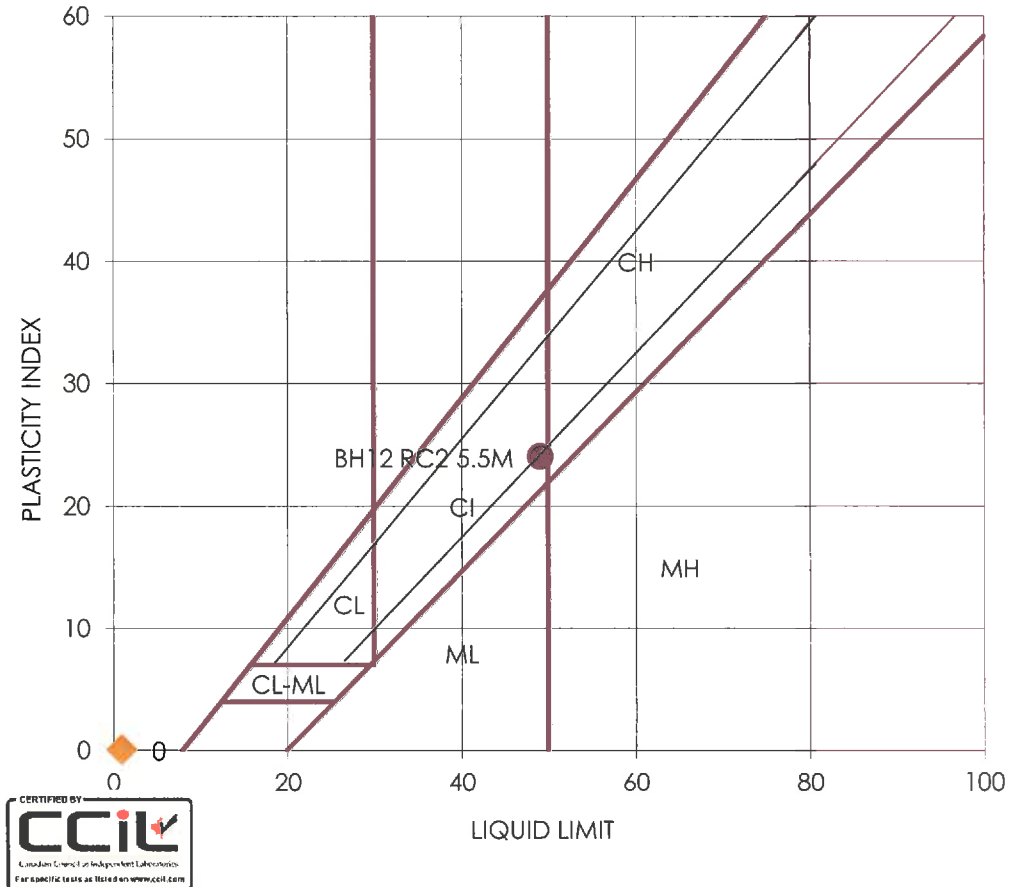

Reporting of these test results constitutes a testing service only. Engineering interpretation or evaluation of the test results is provided only on written request. The data presented above is for the sole use of the client stipulated above. STANTEC is not responsible, nor can be held liable, for the use of this report by any other party, with or without the knowledge of STANTEC.

Reviewed By:



Atterberg Limits
 ASTM D4318
 Method B- One Point

Client: Aurum Industrial Development Partnership
 Project Name: Aurum Road Creek Crossing
 Project No: 123312651
 Date Received: September 19, 2016
 Date Tested: November 2, 2016
 Tested By: JA

OFFICE
 10160 - 112 ST
 Edmonton, Alberta
 Canada T5K 2L6
 Tel: (780) 917-7000

LABORATORY
 10575 106 ST
 Edmonton, Alberta
 Canada T5H 2X5
 Tel: (780) 917-7463

Sample:		Sample:	
BH13 RC1 - 6.35M		BH15 RC2 - 9.17M	
LIQUID		LIQUID	
1	2	Trial No.	
25	26	Number of Blows	26
20B	39B	Container Number	8B
42.63	41.74	Wt. Sample (wet+tare)(g)	36.09
35.10	34.47	Wt. Sample (dry+tare)(g)	28.76
15.42	15.41	Wt. Tare (g)	15.34
19.7	19.1	Wt. Dry Soil (g)	13.4
7.5	7.3	Wt. Water (g)	7.3
38.3%	38.1%	Water Content (%)	54.6%
38.3%	38.3%	Corrected Water Content (%)	54.9%
			55.2%
PLASTIC		PLASTIC	
1	2	Trial No.	
BA	AF	Container Number	BB
20.62	21.29	Wt. Sample (wet+tare)(g)	20.85
19.57	20.17	Wt. Sample (dry+tare)(g)	19.44
13.94	14.07	Wt. Tare (g)	14.2
5.6	6.1	Wt. Dry Soil (g)	5.2
1.1	1.1	Wt. Water (g)	1.4
18.7%	18.4%	Water Content (%)	26.9%
			26.8%
AVERAGE VALUES		AVERAGE VALUES	
1	2	1	2
LL	38	LL	55
PL	19	PL	27
PI	19	PI	28
CLASSIFICATION		CLASSIFICATION	
CI		CH	

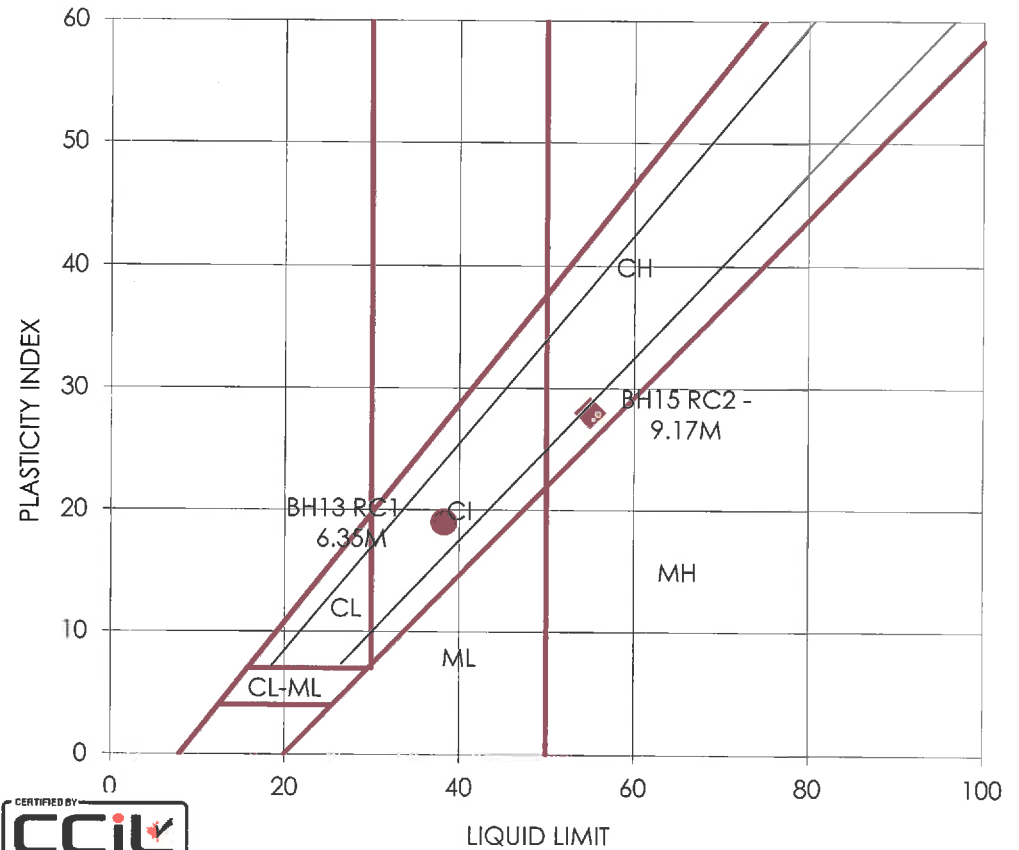

Reporting of these test results constitutes a testing service only. Engineering interpretation or evaluation of the test results is provided only on written request. The data presented above is for the sole use of the client stipulated above. STANTEC is not responsible, nor can be held liable, for the use of this report by any other party, with or without the knowledge of STANTEC.

Reviewed By: [Signature]



Atterberg Limits
 ASTM D4318
 Method B- One Point

Client: Aurum Industrial Development Partnership
 Project Name: Aurum Road Creek Crossing
 Project No: 123312651
 Date Received: September 19, 2016
 Date Tested: October 13, 2016
 Tested By: JA

OFFICE
 10160 - 112 ST
 Edmonton, Alberta
 Canada T5K 2L6
 Tel: (780) 917-7000

LABORATORY
 10575 106 ST
 Edmonton, Alberta
 Canada T5H 2X5
 Tel: (780) 917-7463

Sample: BH14 BULK		Sample: BH15 SS4	
LIQUID		LIQUID	
1	2	Trial No.	
24	26	Number of Blows	21
26B	23B	Container Number	23B
42.12	39.03	Wt. Sample (wet+tare)(g)	37.39
34.82	32.55	Wt. Sample (dry+tare)(g)	28.65
15.52	15.30	Wt. Tare (g)	15.27
19.3	17.3	Wt. Dry Soil (g)	13.4
7.3	6.5	Wt. Water (g)	8.7
37.8%	37.6%	Water Content (%)	65.3%
37.6%	37.7%	Corrected Water Content (%)	64.0%
PLASTIC		PLASTIC	
1	2	Trial No.	
BJ	BK	Container Number	BD
20.38	20.59	Wt. Sample (wet+tare)(g)	20.57
19.41	19.67	Wt. Sample (dry+tare)(g)	19.14
13.98	14.31	Wt. Tare (g)	14.12
5.4	5.4	Wt. Dry Soil (g)	5.0
1.0	0.9	Wt. Water (g)	1.4
17.9%	17.2%	Water Content (%)	28.5%
AVERAGE VALUES		AVERAGE VALUES	
1	2	1	2
LL	38	LL	64
PL	18	PL	28
PI	20	PI	36
CLASSIFICATION		CLASSIFICATION	
CI		CH	

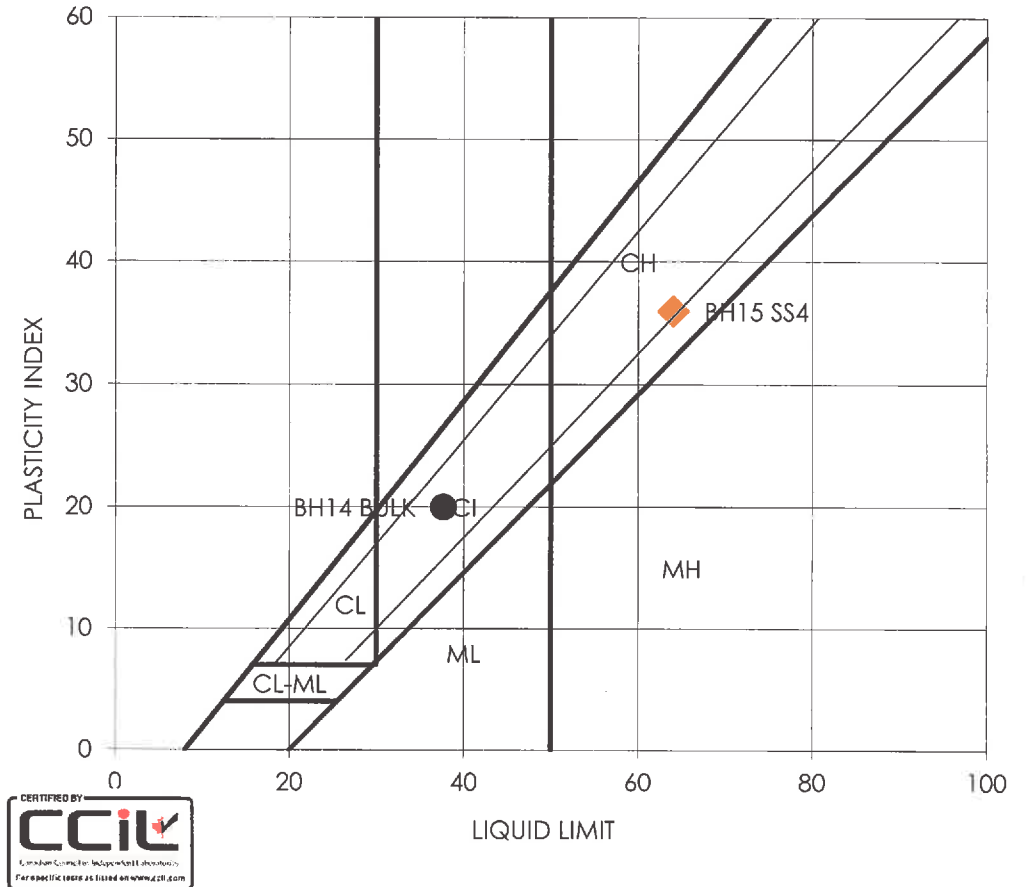

Reporting of these test results constitutes a testing service only. Engineering interpretation or evaluation of the test results is provided only on written request. The data presented above is for the sole use of the client stipulated above. STANTEC is not responsible, nor can be held liable, for the use of this report by any other party, with or without the knowledge of STANTEC.

Reviewed By:





Atterberg Limits
 ASTM D4318
 Method B- One Point

Client: Aurum Industrial Development Partnership
 Project Name: Aurum Road Creek Crossing
 Project No: 123312651
 Date Received: September 19, 2016
 Date Tested: October 13, 2016
 Tested By: JA

OFFICE
 10160 - 112 ST
 Edmonton, Alberta
 Canada T5K 2L6
 Tel: (780) 917-7000

LABORATORY
 10575 106 ST
 Edmonton, Alberta
 Canada T5H 2X5
 Tel: (780) 917-7463

Sample: BH16 BULK		Sample: BH17 BULK	
LIQUID		LIQUID	
1	2	Trial No.	
30	30	Number of Blows	23 24
38B	15B	Container Number	20B 39B
41.61	40.42	Wt. Sample (wet+tare)(g)	39.02 40.85
33.61	32.79	Wt. Sample (dry+tare)(g)	31.45 32.80
15.59	15.55	Wt. Tare (g)	15.48 15.40
18.0	17.2	Wt. Dry Soil (g)	16.0 17.4
8.0	7.6	Wt. Water (g)	7.6 8.1
44.4%	44.3%	Water Content (%)	47.4% 46.3%
45.4%	45.2%	Corrected Water Content (%)	46.9% 46.0%
PLASTIC		PLASTIC	
1	2	Trial No.	
AK	AN	Container Number	BA AF
20.48	20.33	Wt. Sample (wet+tare)(g)	20.38 20.5
19.42	19.27	Wt. Sample (dry+tare)(g)	19.28 19.51
14.26	14.11	Wt. Tare (g)	13.3 14.07
5.2	5.2	Wt. Dry Soil (g)	6.0 5.4
1.1	1.1	Wt. Water (g)	1.1 1.0
20.5%	20.5%	Water Content (%)	18.4% 18.2%
AVERAGE VALUES		AVERAGE VALUES	
1	2	1	2
LL	45	LL	46
PL	21	PL	18
PI	24	PI	28
CLASSIFICATION		CLASSIFICATION	

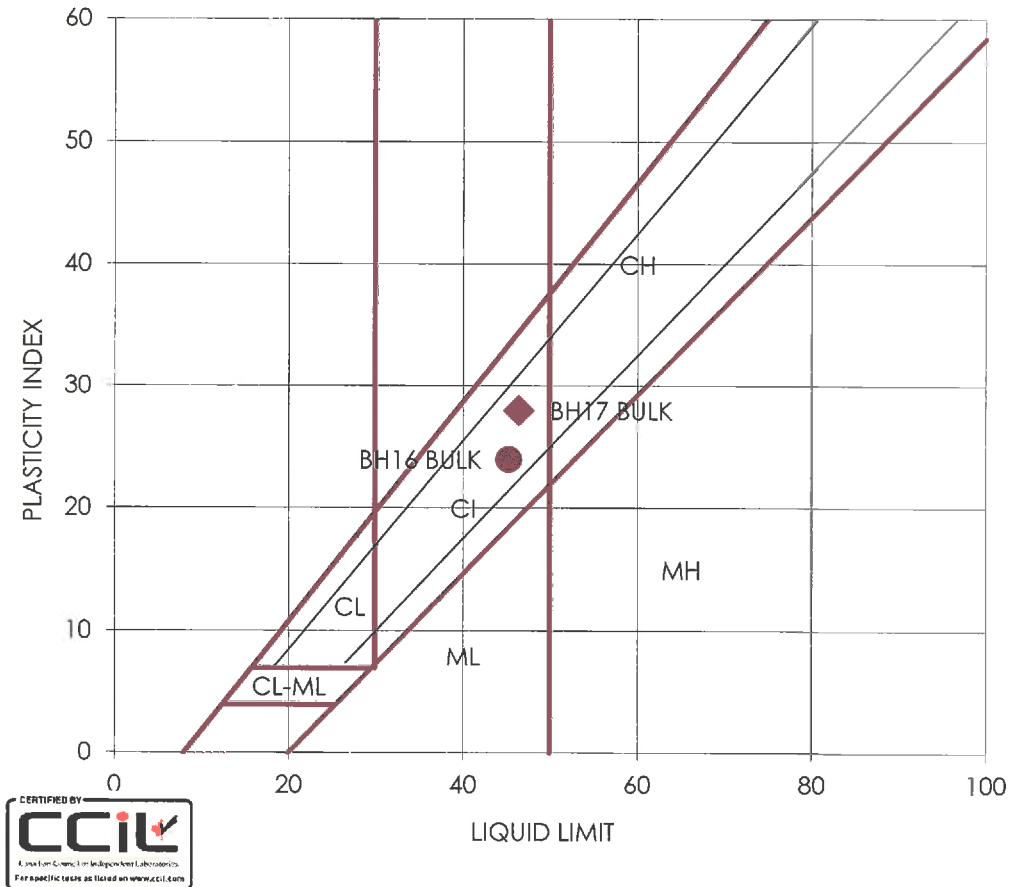

Reporting of these test results constitutes a testing service only. Engineering interpretation or evaluation of the test results is provided only on written request. The data presented above is for the sole use of the client stipulated above. STANTEC is not responsible, nor can be held liable, for the use of this report by any other party, with or without the knowledge of STANTEC.

Reviewed By:



Atterberg Limits
 ASTM D4318
 Method B- One Point

Client: Aurum Road Creek Crossing
 Project Name: Aurum Industrial Dev. Partnership
 Project No: 123312651
 Date Received: November 7, 2016
 Date Tested: December 2, 2016
 Tested By: C. Woods

OFFICE
 325 - 25th Street SE
 Suite 200
 Calgary, Alberta
 Canada T2A 7H8
 Tel: (403) 716-8000

LABORATORY
 10830 - 46th Street SE
 Calgary, Alberta
 Canada T2C 1G4
 Tel: (403) 253-7876

Sample:		Sample:	
BH06 RC7			
LIQUID		LIQUID	
1	2	Trial No.	
29	29	Number of Blows	
		Container Number	
26.68	25.64	Wt. Sample (wet+tare) (g)	
19.23	18.49	Wt. Sample (dry+tare) (g)	
1.25	1.16	Wt. Tare (g)	
18.0	17.3	Wt. Dry Soil (g)	
7.5	7.2	Wt. Water (g)	
41.4%	41.3%	Water Content (%)	
42.2%	42.0%	Corrected Water Content (%)	
PLASTIC		PLASTIC	
1	2	Trial No.	
		Container Number	
23.59	22.85	Wt. Sample (wet+tare) (g)	
22.26	21.59	Wt. Sample (dry+tare) (g)	
13.78	13.77	Wt. Tare (g)	
8.5	7.8	Wt. Dry Soil (g)	
1.3	1.3	Wt. Water (g)	
15.7%	16.1%	Water Content (%)	
AVERAGE VALUES		AVERAGE VALUES	
1	2	1	2
LL	42	LL	
PL	16	PL	
PI	26	PI	
CLASSIFICATION		CLASSIFICATION	
CI		NON-PLASTIC	

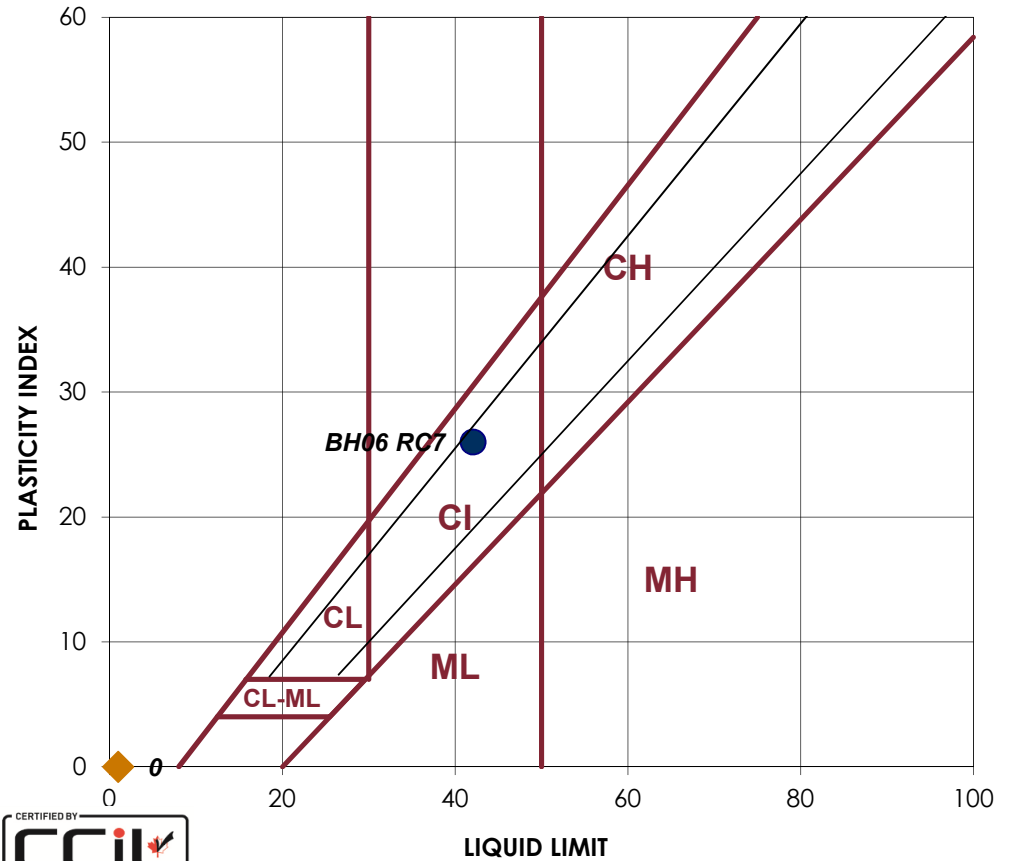

Reporting of these test results constitutes a testing service only. Engineering interpretation or evaluation of the test results is provided only on written request. The data presented above is for the sole use of the client stipulated above. STANTEC is not responsible, nor can be held liable, for the use of this report by any other party, with or without the knowledge of STANTEC.

Reviewed By: _____



Grain Size Analysis
 Hydrometer Report
 ASTM D422
 CANFEM

Client: Aurum Industrial Development Partnership
 Project Name: Aurum Road Creek Crossing
 Project No: 123312651.400

OFFICE **LABORATORY**
 10160 - 112 ST 10575 106 ST
 Edmonton, Alberta Edmonton, Alberta
 Canada T5K 2L6 Canada T5H 2X5
 Tel: (780) 917-7000 Tel: (780) 917-7463

SAMPLE No.: BULK
 SOURCE: BH1
 TESTED BY: JA

DATE TESTED: October 14, 2016
 DATE RECEIVED: September 19, 2016
 SAMPLE DESCRIPTION: Silty, sandy clay

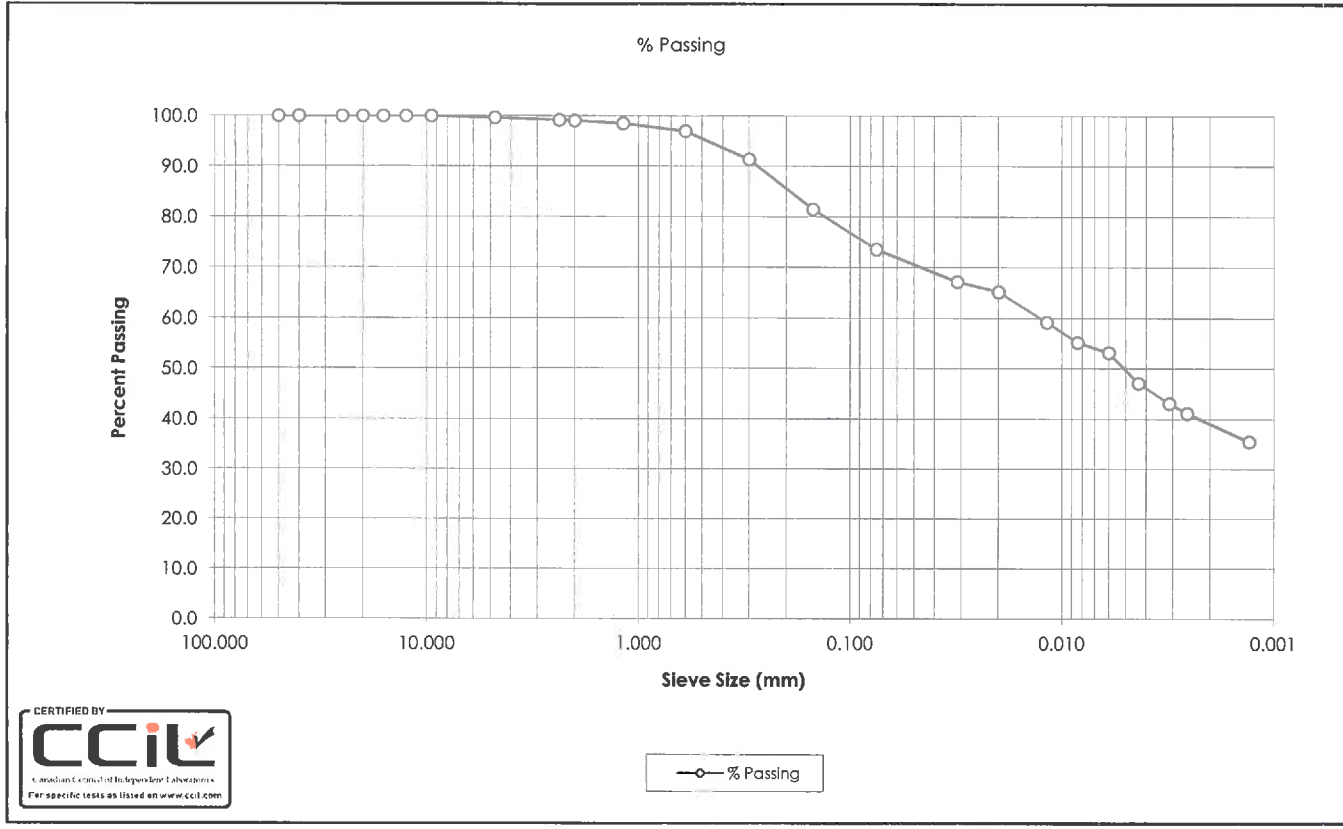

Sieve (mm)	Sample % Passing	Sieve (mm)	Sample % Passing
50.0	100.0	0.0060	53.1
40.0	100.0	0.0043	47.1
25.0	100.0	0.0031	43.1
20.0	100.0	0.0026	41.1
16.0	100.0	0.0013	35.5
12.5	100.0		
9.5	100.0		
4.75	99.6		
2.36	99.1		
2.00	99.0		
1.18	98.4		
0.600	96.9		
0.300	91.3		
0.150	81.5		
0.075	73.5		
0.0311	67.2		
0.0199	65.2		
0.0117	59.2		
0.0084	55.2		
Gravel:	0.4%	D ₁₀ :	-
Sand:	26.1%	D ₃₀ :	-
Silt:	34.5%	D ₆₀ :	0.0129
Clay:	39.1%	C _u :	-
		C _c :	-



Comments:

Reviewed by:

Reporting of these test results constitutes a testing service only. Engineering interpretation or evaluation of the test results is provided only on written request. The data presented above is for the sole use of the client stipulated above. Stantec is not responsible, nor can be held liable, for the use of this report by any other party, with or without the knowledge of Stantec.



Grain Size Analysis

Hydrometer Report
ASTM D422
CANFEM

Client: Aurum Industrial Development Partnership
Project Name: Aurum Road Creek Crossing
Project No: 123312651.400

OFFICE **LABORATORY**
10160 - 112 ST 10575 106 ST
Edmonton, Alberta Edmonton, Alberta
Canada T5K 2L6 Canada T5H 2X5

Tel: (780) 917-7000 Tel: (780) 917-7463

SAMPLE No.: SS15
SOURCE: BH2
TESTED BY: JA

DATE TESTED: October 14, 2016
DATE RECEIVED: September 19, 2016
SAMPLE DESCRIPTION: Silty, clayey sand

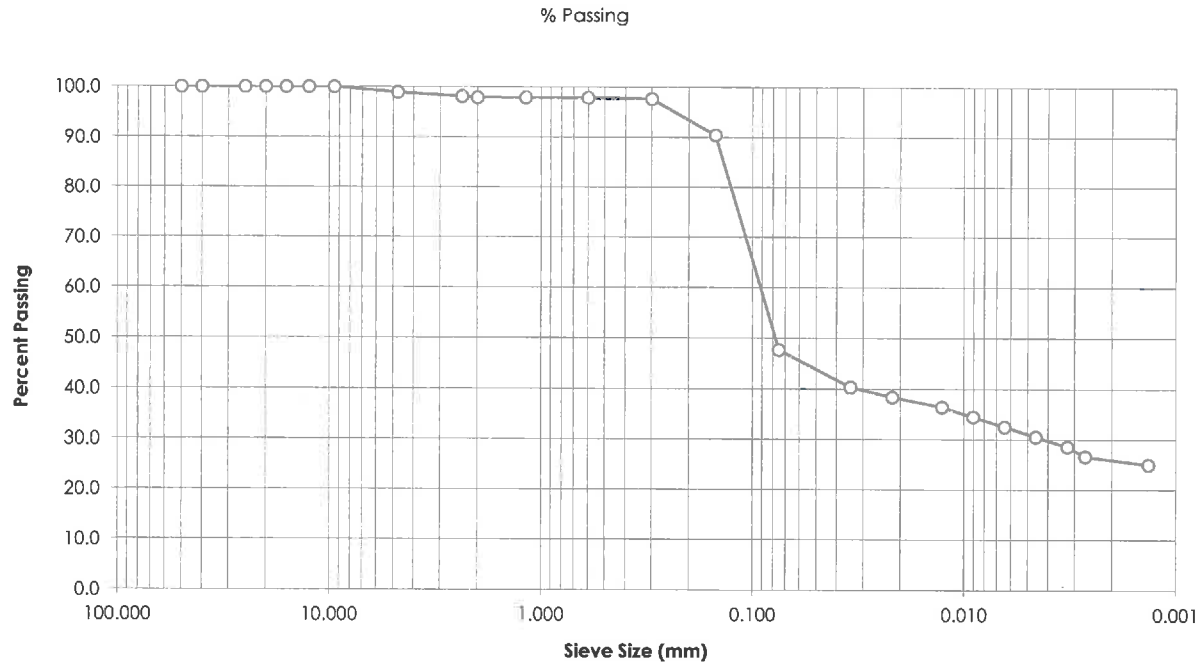

Sieve (mm)	Sample % Passing	Sieve (mm)	Sample % Passing
50.0	100.0	0.0064	32.5
40.0	100.0	0.0046	30.5
25.0	100.0	0.0032	28.6
20.0	100.0	0.0027	26.6
16.0	100.0	0.0013	25.0
12.5	100.0		
9.5	100.0		
4.75	98.9		
2.36	98.1		
2.00	97.9		
1.18	97.9		
0.600	97.9		
0.300	97.7		
0.150	90.5		
0.075	47.7		
0.0343	40.4		
0.0218	38.4		
0.0127	36.4		
0.0090	34.5		
Gravel:	1.1%	D ₁₀ :	-
Sand:	51.2%	D ₃₀ :	0.0042
Silt:	21.8%	D ₆₀ :	0.1019
Clay:	25.9%	C _u :	-
		C _c :	-



—○— % Passing

Comments:

Reviewed by:

Reporting of these test results constitutes a testing service only. Engineering interpretation or evaluation of the test results is provided only on written request. The data presented above is for the sole use of the client stipulated above. Stantec is not responsible, nor can be held liable, for the use of this report by any other party, with or without the knowledge of Stantec.

[Handwritten Signature]



Grain Size Analysis

Hydrometer Report
 ASTM D422
 CANFEM

Client: Aurum Industrial Development Partnership
 Project Name: Aurum Road Creek Crossing
 Project No: 123312651.400

OFFICE

10160 - 112 ST
 Edmonton, Alberta
 Canada T5K 2L6

LABORATORY

10575 106 ST
 Edmonton, Alberta
 Canada T5H 2X5

Tel: (780) 917-7000

Tel: (780) 917-7463

SAMPLE No.: 6.0M
 SOURCE: BH03 RC1
 TESTED BY: JA

DATE TESTED: November 2, 2016
 DATE RECEIVED: September 7, 2016
 SAMPLE DESCRIPTION: Clay and silt, trace sand

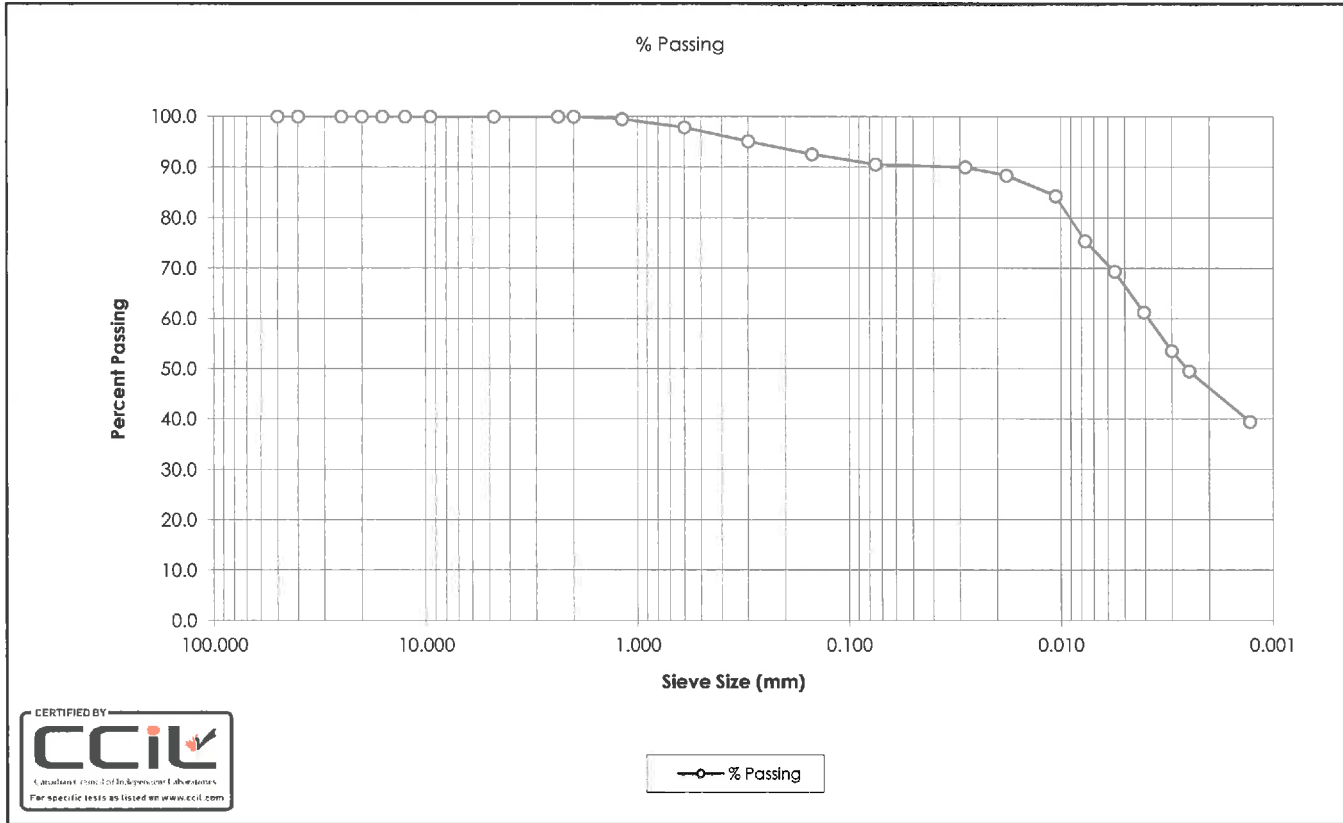

Sieve (mm)	Sample % Passing	Sieve (mm)	Sample % Passing
50.0	100.0	0.0056	69.3
40.0	100.0	0.0041	61.3
25.0	100.0	0.0030	53.6
20.0	100.0	0.0025	49.5
16.0	100.0	0.0013	39.4
12.5	100.0		
9.5	100.0		
4.75	100.0		
2.36	100.0		
2.00	100.0		
1.18	99.5		
0.600	97.8		
0.300	95.1		
0.150	92.6		
0.075	90.5		
0.0282	90.0		
0.0181	88.3		
0.0106	84.3		
0.0077	75.4		
Gravel:	0.0%	D ₁₀ :	-
Sand:	9.5%	D ₃₀ :	-
Silt:	44.3%	D ₆₀ :	0.0039
Clay:	46.2%	C _u :	-
		C _c :	-

Comments: Coal in sample

Reviewed by:

Reporting of these test results constitutes a testing service only. Engineering interpretation or evaluation of the test results is provided only on written request. The data presented above is for the sole use of the client stipulated above. Stantec is not responsible, nor can be held liable, for the use of this report by any other party, with or without the knowledge of Stantec.



Grain Size Analysis
Hydrometer Report
ASTM D422
CANFEM

Client: Aurum Industrial Development Partnership
Project Name: Aurum Road Creek Crossing
Project No: 123312651.400

OFFICE **LABORATORY**
10160 - 112 ST 10575 106 ST
Edmonton, Alberta Edmonton, Alberta
Canada T5K 2L6 Canada T5H 2X5

Tel: (780) 917-7000 Tel: (780) 917-7463

SAMPLE No.: 12.75M DATE TESTED: November 2, 2016
SOURCE: BH4 RC5 DATE RECEIVED: September 16, 2016
TESTED BY: JA SAMPLE DESCRIPTION: Silty clay and sand

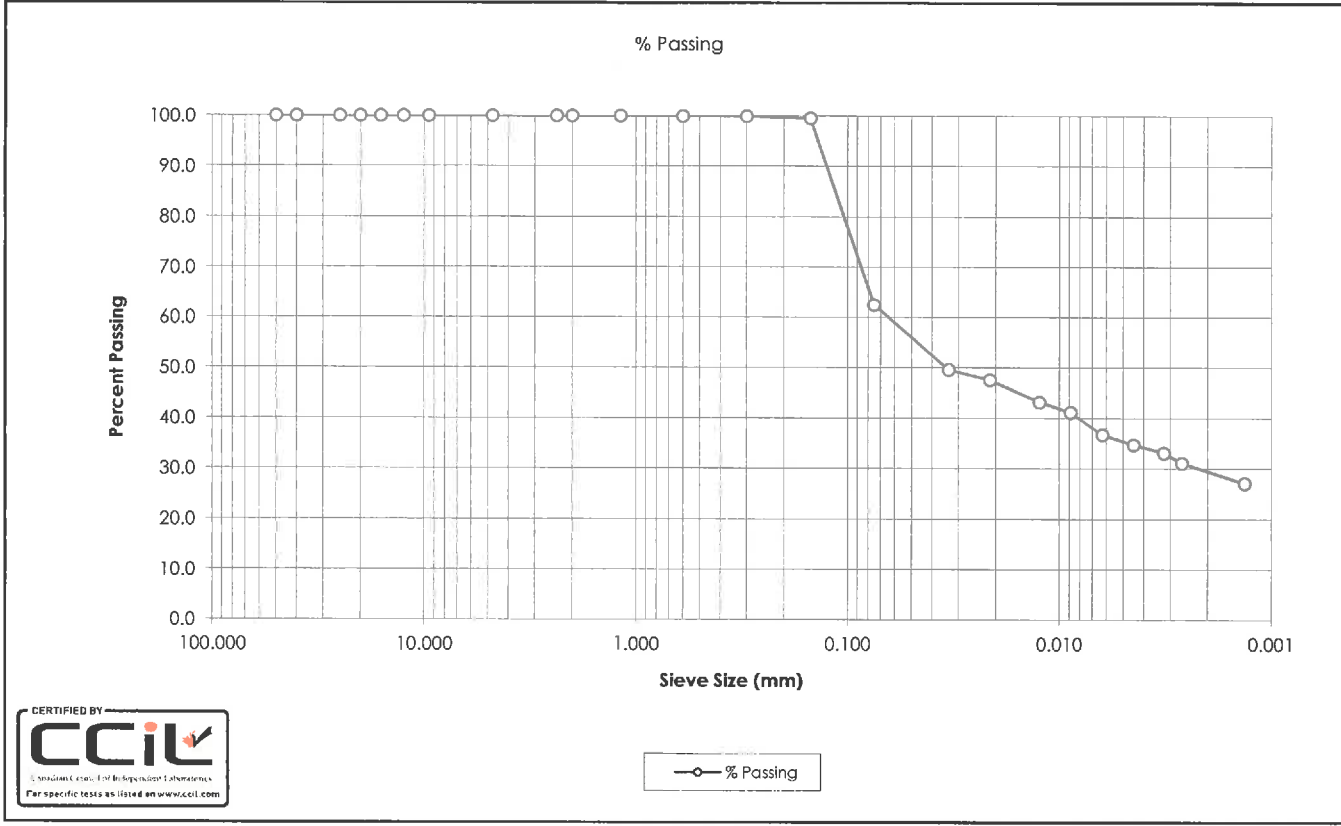

Sieve (mm)	Sample % Passing	Sieve (mm)	Sample % Passing
50.0	100.0	0.0063	36.7
40.0	100.0	0.0045	34.7
25.0	100.0	0.0032	33.1
20.0	100.0	0.0026	31.1
16.0	100.0	0.0013	27.1
12.5	100.0		
9.5	100.0		
4.75	100.0		
2.36	100.0		
2.00	100.0		
1.18	100.0		
0.600	99.9		
0.300	99.9		
0.150	99.5		
0.075	62.4		
0.0333	49.6		
0.0213	47.6		
0.0124	43.2		
0.0089	41.1		
Gravel:	0.0%	D ₁₀ :	-
Sand:	37.6%	D ₃₀ :	0.0023
Silt:	33.0%	D ₆₀ :	0.0678
Clay:	29.5%	C _u :	-
		C _c :	-

Comments:

Reviewed by:

Reporting of these test results constitutes a testing service only. Engineering interpretation or evaluation of the test results is provided only on written request. The data presented above is for the sole use of the client stipulated above. Stantec is not responsible, nor can be held liable, for the use of this report by any other party, with or without the knowledge of Stantec.



Grain Size Analysis
 Hydrometer Report
 ASTM D422
 CANFEM

Client: Aurum Industrial Development Partnership
 Project Name: Aurum Road Creek Crossing
 Project No: 123312651.400

OFFICE
 10160 - 112 ST
 Edmonton, Alberta
 Canada T5K 2L6
 Tel: (780) 917-7000

LABORATORY
 10575 106 ST
 Edmonton, Alberta
 Canada T5H 2X5
 Tel: (780) 917-7463

SAMPLE No.: 18.9M
 SOURCE: BH06 RC5
 TESTED BY: JA

DATE TESTED: November 2, 2016
 DATE RECEIVED: September 16, 2016
 SAMPLE DESCRIPTION: Clay and silt, some sand

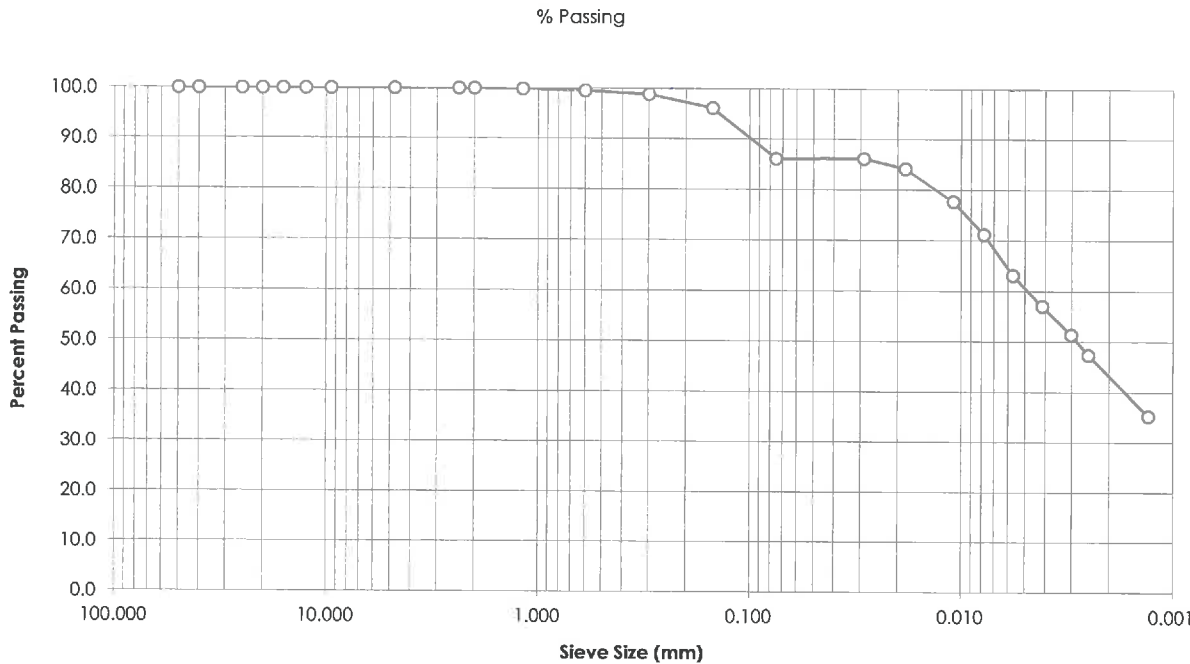

Sieve (mm)	Sample % Passing	Sieve (mm)	Sample % Passing
50.0	100.0	0.0057	63.1
40.0	100.0	0.0041	57.1
25.0	100.0	0.0030	51.4
20.0	100.0	0.0025	47.4
16.0	100.0	0.0013	35.3
12.5	100.0		
9.5	100.0		
4.75	100.0		
2.36	100.0		
2.00	100.0		
1.18	99.8		
0.600	99.5		
0.300	98.9		
0.150	96.1		
0.075	86.1		
0.0289	86.1		
0.0184	84.1		
0.0109	77.7		
0.0078	71.2		
Gravel:	0.0%	D ₁₀ :	-
Sand:	13.9%	D ₃₀ :	-
Silt:	42.8%	D ₆₀ :	0.0049
Clay:	43.2%	C _u :	-
		C _c :	-



—○— % Passing

Comments:

Reviewed by:

Reporting of these test results constitutes a testing service only. Engineering interpretation or evaluation of the test results is provided only on written request. The data presented above is for the sole use of the client stipulated above. Stantec is not responsible, nor can be held liable, for the use of this report by any other party, with or without the knowledge of Stantec.



Grain Size Analysis

Hydrometer Report
 ASTM D422
 CANFEM

Client: Aurum Industrial Dev. Partnership
 Project Name: Aurum Road Creek Crossing
 Project No: 123312651

OFFICE

325 - 25th Street SE
 Suite 200
 Calgary, Alberta
 Canada T2A 7H8
 Tel: (403) 716-8000

LABORATORY

10830 - 46th Street SE
 Calgary, Alberta
 Canada T2C 1G4
 Tel: (403) 253-7876

SAMPLE No.: RC7
 SOURCE: BH06
 TESTED BY: B. Pelkey

DATE TESTED: December 2, 2016
 DATE RECEIVED: November 7, 2016
 SAMPLE DESCRIPTION: Sand and Clay (CI)

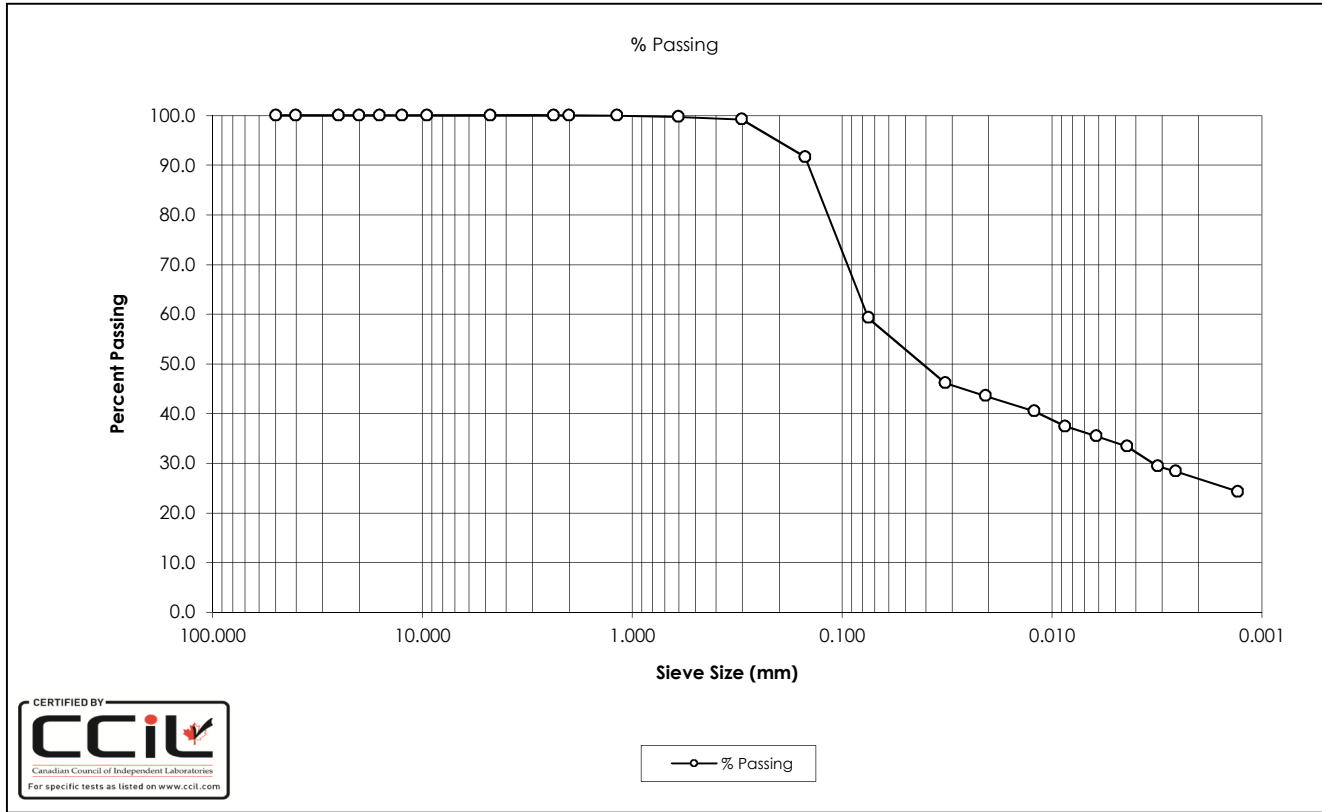

Sieve (mm)	Sample % Passing	Sieve (mm)	Sample % Passing
50.0	100.0	0.0061	35.4
40.0	100.0	0.0044	33.4
25.0	100.0	0.0031	29.3
20.0	100.0	0.0026	28.3
16.0	100.0	0.0013	24.3
12.5	100.0		
9.5	100.0		
4.75	100.0		
2.36	100.0		
2.00	100.0		
1.18	100.0		
0.600	99.8		
0.300	99.2		
0.150	91.7		
0.075	59.3		
0.0321	46.1		
0.0207	43.5		
0.0121	40.5		
0.0086	37.4		
Gravel:	0.0%	D ₁₀ :	-
Sand:	40.7%	D ₃₀ :	0.0033
Silt:	32.4%	D ₆₀ :	0.0771
Clay:	26.8%	C _u :	-
		C _c :	-

Comments: Sample description (MUSCS) derived from both the Grain Size and Atterberg Limit test results.

Reviewed by:

Reporting of these test results constitutes a testing service only. Engineering interpretation or evaluation of the test results is provided only on written request. The data presented above is for the sole use of the client stipulated above. Stantec is not responsible, nor can be held liable, for the use of this report by any other party, with or without the knowledge of Stantec.



Grain Size Analysis
ASTM C136, ASTM C117

Client: Aurum Industrial Development Partnership
Project Name: Aurum Road Creek Crossing
Project No: 123312651.400

OFFICE **LABORATORY**
10160 - 112 ST 10575 106 ST
Edmonton, Alberta Edmonton, Alberta
Canada T5K 2L6 Canada T5H 2X5

Tel: (780) 917-7000 Tel: (780) 917-7463

SAMPLE No.: BS8
SOURCE: BH6
TESTED BY: JA

DATE RECEIVED: September 19, 2016
DATE TESTED: November 30, 2016
SAMPLE DESCRIPTION: Sand with fines

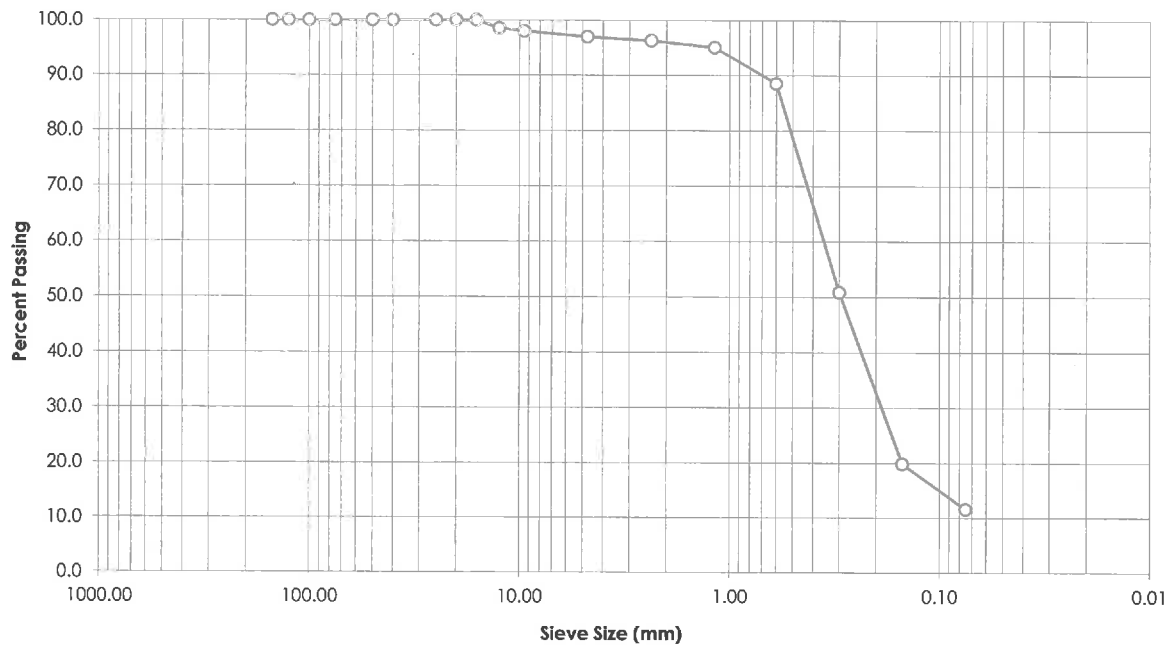

Sieve (mm)	Sample % Passing	Specifications	
		Lower	Upper
150.0	100.0	-	-
125.0	100.0	-	-
100.0	100.0	-	-
75.0	100.0	-	-
50.0	100.0	-	-
40.0	100.0	-	-
25.0	100.0	-	-
20.0	100.0	-	-
16.0	100.0	-	-
12.5	98.5	-	-
9.5	98.0	-	-
4.75	97.0	-	-
2.36	96.3	-	-
1.18	95.1	-	-
0.600	88.5	-	-
0.300	50.9	-	-
0.150	19.9	-	-
0.075	11.6	-	-
Cobble:	0.0%	D ₁₀ :	-
Gravel:	3.0%	D ₃₀ :	0.2157
Sand:	85.4%	D ₆₀ :	0.3896
Fines:	11.6%	C _u :	-
		C _c :	-



—○— % Passing -◇- Upper Limit -△- Lower Limit

Comments:

Reviewed by:

Reporting of these test results constitutes a testing service only. Engineering interpretation or evaluation of the test results is provided only on written request. The data presented above is for the sole use of the client stipulated above. Stantec is not responsible, nor can be held liable, for the use of this report by any other party, with or without the knowledge of Stantec.



Grain Size Analysis

Hydrometer Report
 ASTM D422
 CANFEM

Client: Aurum Industrial Development Partnership
 Project Name: Aurum Road Creek Crossing
 Project No: 123312651

OFFICE

325 - 25th Street SE
 Suite 200
 Calgary, Alberta
 Canada T2A 7H8
 Tel: (403) 716-8000

LABORATORY

10830 - 46th Street SE
 Calgary, Alberta
 Canada T2C 1G4
 Tel: (403) 253-7876

SAMPLE No.: RC4
 SOURCE: BH08
 TESTED BY: C. Woods

DATE TESTED: November 14, 2016
 DATE RECEIVED: October 28, 2016
 SAMPLE DESCRIPTION: Clay (CH), Trace Sand

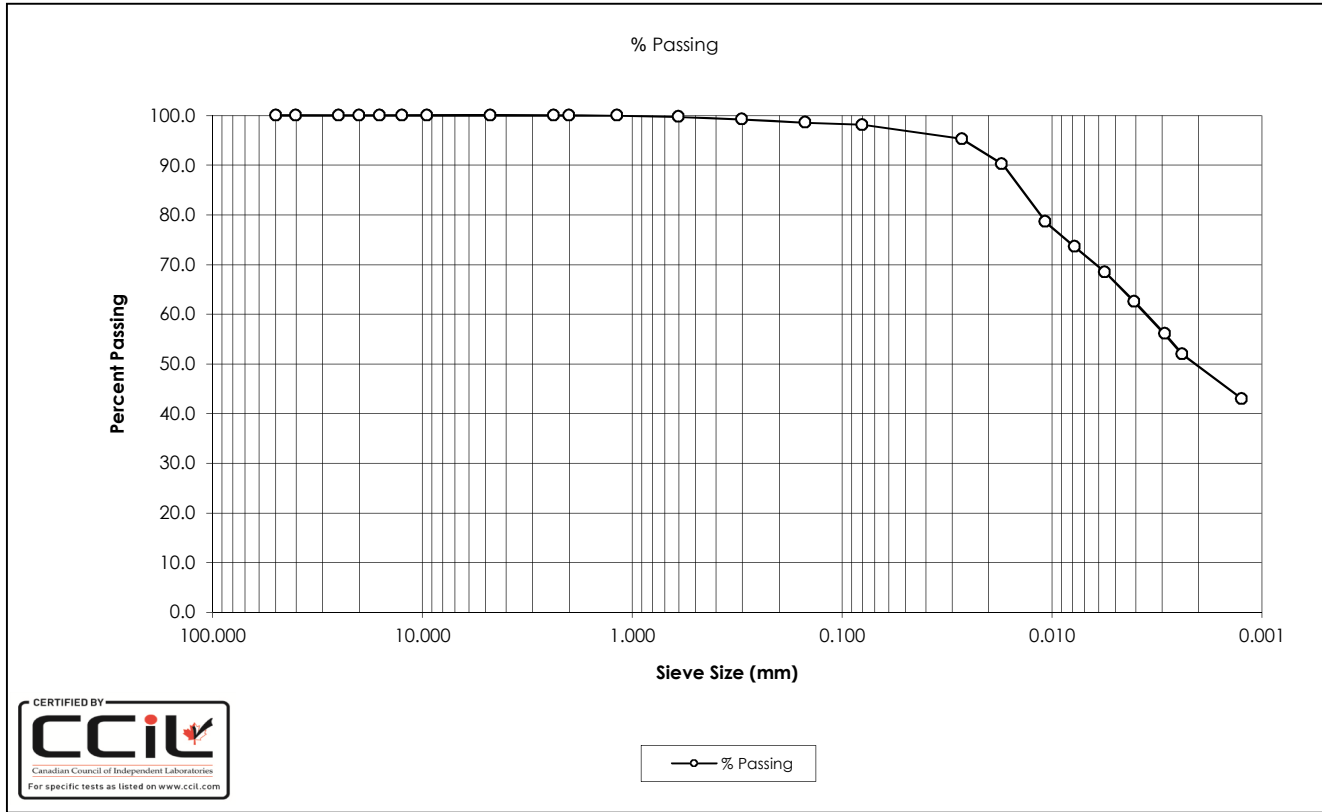

Sieve (mm)	Sample % Passing	Sieve (mm)	Sample % Passing
50.0	100.0	0.0056	68.5
40.0	100.0	0.0041	62.5
25.0	100.0	0.0029	56.0
20.0	100.0	0.0024	52.0
16.0	100.0	0.0012	42.9
12.5	100.0		
9.5	100.0		
4.75	100.0		
2.36	100.0		
2.00	100.0		
1.18	100.0		
0.600	99.7		
0.300	99.2		
0.150	98.6		
0.080	98.1		
0.0269	95.3		
0.0173	90.3		
0.0107	78.6		
0.0078	73.5		
Gravel:	0.0%	D ₁₀ :	-
Sand:	1.9%	D ₃₀ :	-
Silt:	48.6%	D ₆₀ :	0.0036
Clay:	49.5%	C _u :	-
		C _c :	-

Comments: Sample description (MUSCS) derived from both the Grain Size and Atterberg test results.

Reviewed by:

Reporting of these test results constitutes a testing service only. Engineering interpretation or evaluation of the test results is provided only on written request. The data presented above is for the sole use of the client stipulated above. Stantec is not responsible, nor can be held liable, for the use of this report by any other party, with or without the knowledge of Stantec.



Grain Size Analysis
ASTM C136, ASTM C117

Client: Aurum Industrial Development Partnership
Project Name: Aurum Road Creek Crossing
Project No: 123312651.400

OFFICE **LABORATORY**
10160 - 112 ST 10575 106 ST
Edmonton, Alberta Edmonton, Alberta
Canada T5K 2L6 Canada T5H 2X5

Tel: (780) 917-7000 Tel: (780) 917-7463

SAMPLE No.: BS17
SOURCE: BH7
TESTED BY: JA

DATE RECEIVED: September 19, 2016
DATE TESTED: November 30, 2016
SAMPLE DESCRIPTION: Silty and/or clayey sand with gravel

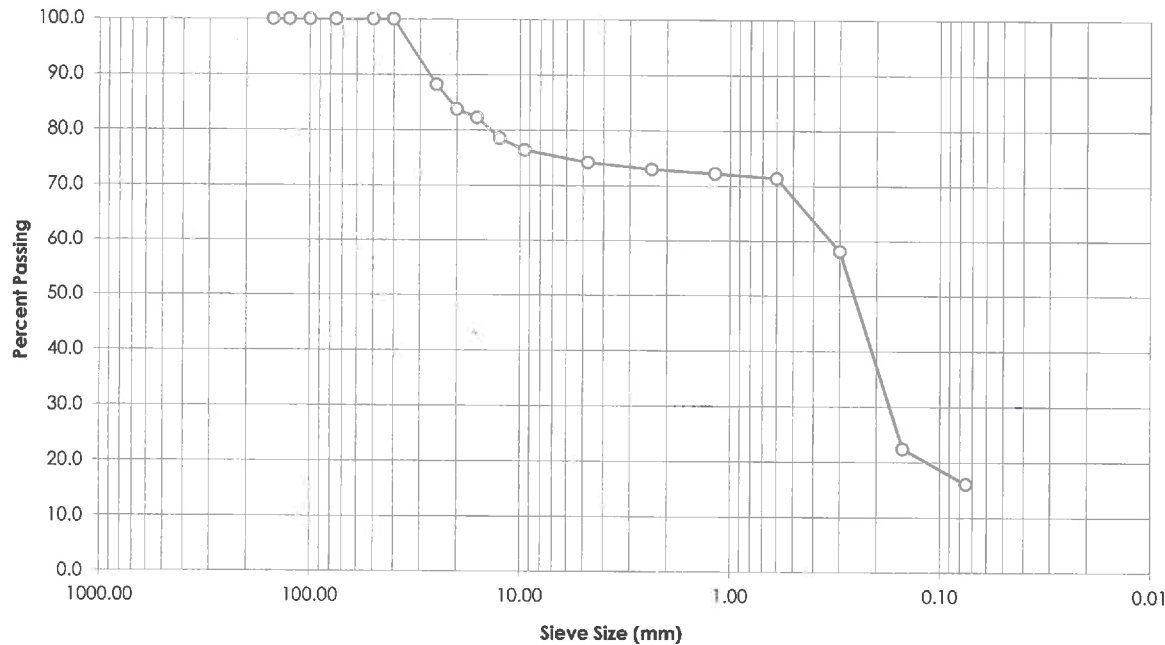

Sieve (mm)	Sample % Passing	Specifications	
		Lower	Upper
150.0	100.0	-	-
125.0	100.0	-	-
100.0	100.0	-	-
75.0	100.0	-	-
50.0	100.0	-	-
40.0	100.0	-	-
25.0	88.2	-	-
20.0	83.7	-	-
16.0	82.2	-	-
12.5	78.5	-	-
9.5	76.4	-	-
4.75	74.2	-	-
2.36	73.0	-	-
1.18	72.2	-	-
0.600	71.4	-	-
0.300	58.1	-	-
0.150	22.4	-	-
0.075	16.1	-	-
Cobble: 0.0%		D ₁₀ :	-
Gravel: 25.8%		D ₃₀ :	0.1958
Sand: 58.1%		D ₆₀ :	0.3463
Fines: 16.1%		C _u :	-
		C _c :	-



—○— % Passing -◇- Upper Limit -△- Lower Limit

Comments:

Reviewed by:

Reporting of these test results constitutes a testing service only. Engineering interpretation or evaluation of the test results is provided only on written request. The data presented above is for the sole use of the client stipulated above. Stantec is not responsible, nor can be held liable, for the use of this report by any other party, with or without the knowledge of Stantec.



Grain Size Analysis

Hydrometer Report
 ASTM D422
 CANFEM

Client: Aurum Industrial Development Partnership
 Project Name: Aurum Road Creek Crossing
 Project No: 123312651.400

OFFICE **LABORATORY**
 10160 - 112 ST 10575 106 ST
 Edmonton, Alberta Edmonton, Alberta
 Canada T5K 2L6 Canada T5H 2X5
 Tel: (780) 917-7000 Tel: (780) 917-7463

SAMPLE No.: 17.11M DATE TESTED: November 3, 2016
 SOURCE: BH09 RC9 DATE RECEIVED: September 15, 2016
 TESTED BY: JA SAMPLE DESCRIPTION: Clay and silt, some sand

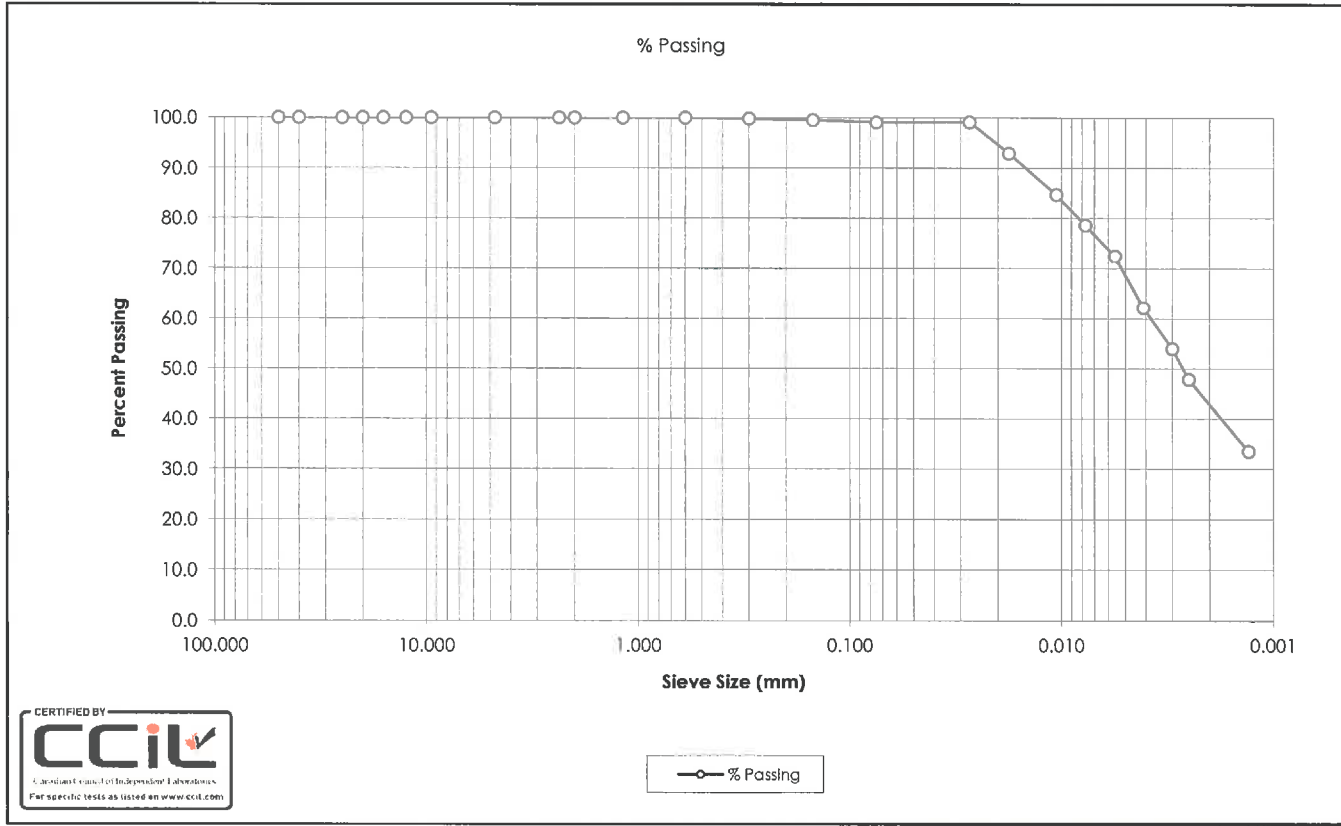

Sieve (mm)	Sample % Passing	Sieve (mm)	Sample % Passing
50.0	100.0	0.0056	72.5
40.0	100.0	0.0041	62.2
25.0	100.0	0.0030	54.0
20.0	100.0	0.0025	47.8
16.0	100.0	0.0013	33.5
12.5	100.0		
9.5	100.0		
4.75	100.0		
2.36	100.0		
2.00	100.0		
1.18	100.0		
0.600	100.0		
0.300	99.8		
0.150	99.5		
0.075	99.1		
0.0272	99.1		
0.0178	93.0		
0.0106	84.8		
0.0077	78.6		
Gravel:	0.0%	D ₁₀ :	-
Sand:	0.9%	D ₃₀ :	-
Silt:	56.2%	D ₆₀ :	0.0038
Clay:	42.8%	C _u :	-
		C _c :	-

Comments:

Reviewed by:

Reporting of these test results constitutes a testing service only. Engineering interpretation or evaluation of the test results is provided only on written request. The data presented above is for the sole use of the client stipulated above. Stantec is not responsible, nor can be held liable, for the use of this report by any other party, with or without the knowledge of Stantec.



Grain Size Analysis

Hydrometer Report
 ASTM D422
 CANFEM

Client: Aurum Industrial Development Partnership
 Project Name: Aurum Road Creek Crossing
 Project No: 123312651.400

OFFICE **LABORATORY**
 10160 - 112 ST 10575 106 ST
 Edmonton, Alberta Edmonton, Alberta
 Canada T5K 2L6 Canada T5H 2X5
 Tel: (780) 917-7000 Tel: (780) 917-7463

SAMPLE No.: 17.11M
 SOURCE: BH09 RC9
 TESTED BY: JA

DATE TESTED: November 3, 2016
 DATE RECEIVED: September 15, 2016
 SAMPLE DESCRIPTION: Clay and silt

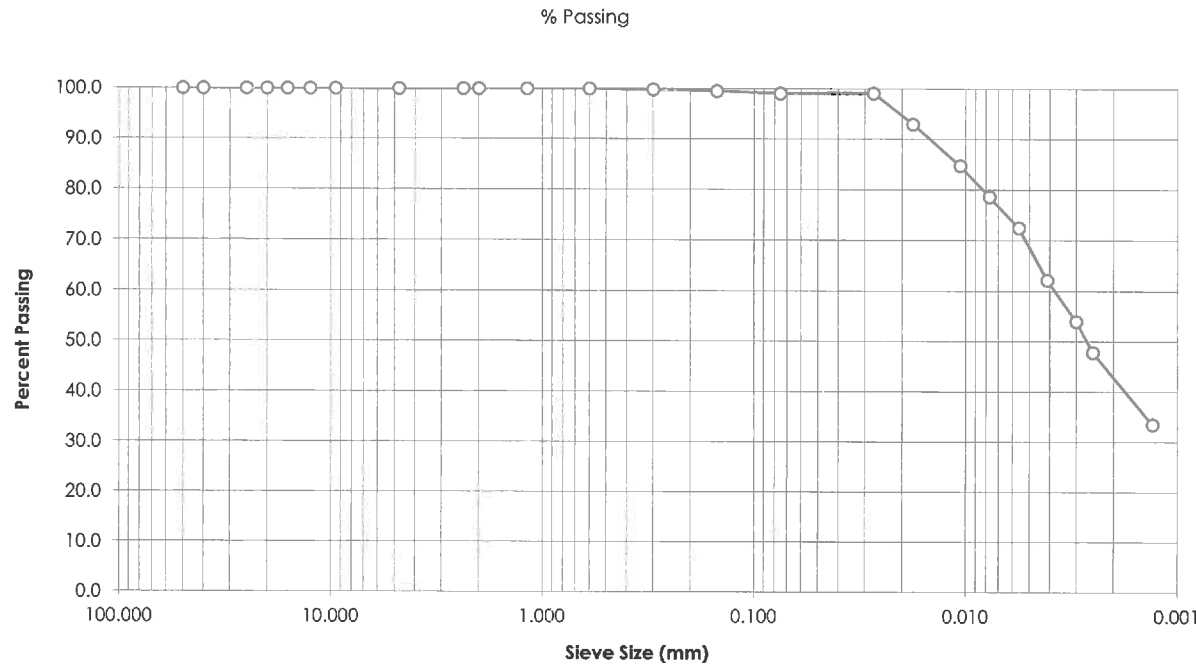

Sieve (mm)	Sample % Passing	Sieve (mm)	Sample % Passing
50.0	100.0	0.0056	72.5
40.0	100.0	0.0041	62.2
25.0	100.0	0.0030	54.0
20.0	100.0	0.0025	47.8
16.0	100.0	0.0013	33.5
12.5	100.0		
9.5	100.0		
4.75	100.0		
2.36	100.0		
2.00	100.0		
1.18	100.0		
0.600	100.0		
0.300	99.8		
0.150	99.5		
0.075	99.1		
0.0272	99.1		
0.0178	93.0		
0.0106	84.8		
0.0077	78.6		
Gravel:	0.0%	D ₁₀ :	-
Sand:	0.9%	D ₃₀ :	-
Silt:	56.2%	D ₆₀ :	0.0038
Clay:	42.8%	C _u :	-
		C _c :	-



—○— % Passing

Comments:

Reviewed by:

Reporting of these test results constitutes a testing service only. Engineering interpretation or evaluation of the test results is provided only on written request. The data presented above is for the sole use of the client stipulated above. Stantec is not responsible, nor can be held liable, for the use of this report by any other party, with or without the knowledge of Stantec.



Grain Size Analysis
Hydrometer Report
ASTM D422
CANFEM

Client: Aurum Industrial Development Partnership
Project Name: Aurum Road Creek Crossing
Project No: 123312651.400

OFFICE **LABORATORY**
10160 - 112 ST 10575 106 ST
Edmonton, Alberta Edmonton, Alberta
Canada T5K 2L6 Canada T5H 2X5

Tel: (780) 917-7000 Tel: (780) 917-7463

SAMPLE No.: BULK
SOURCE: BH14
TESTED BY: JA

DATE TESTED: October 14, 2016
DATE RECEIVED: September 19, 2016
SAMPLE DESCRIPTION: Sandy clay and silt

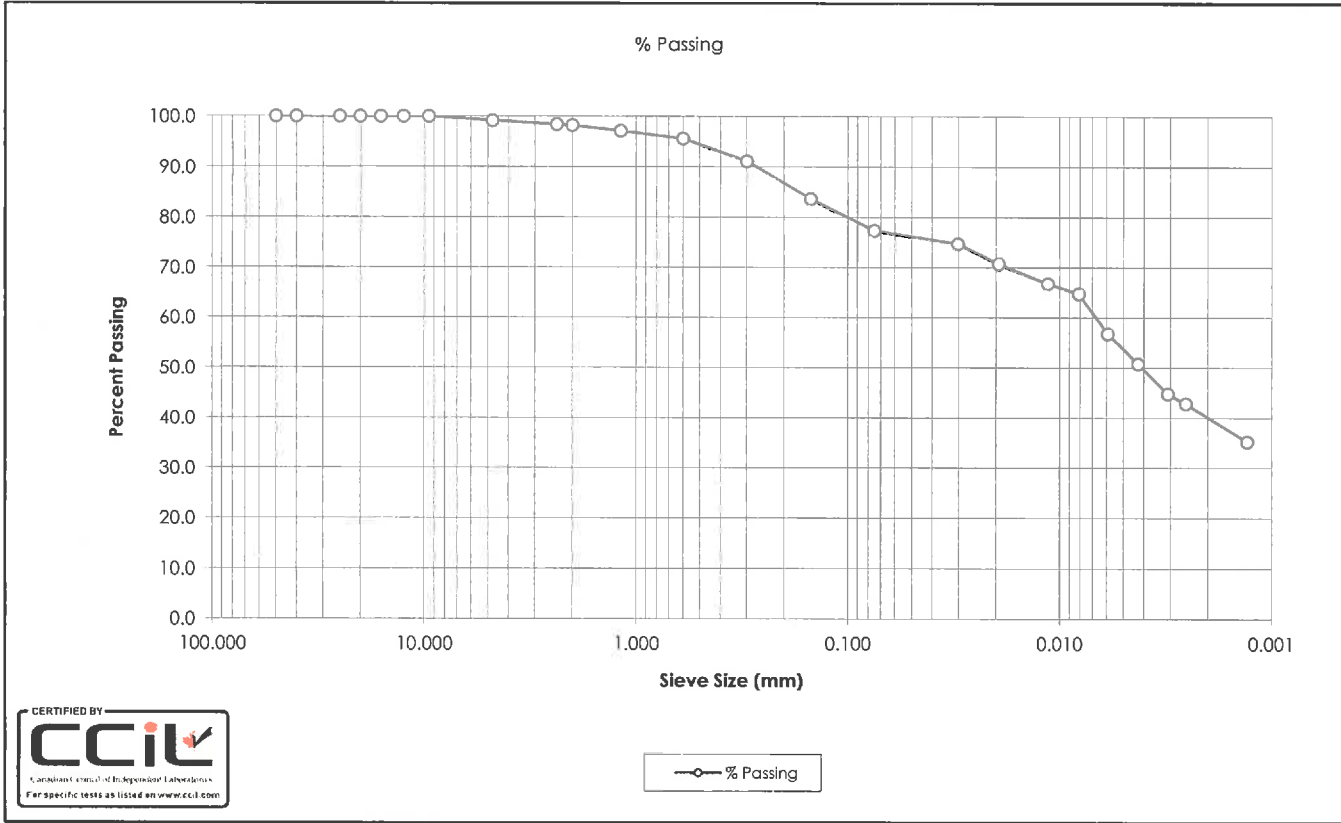

Sieve (mm)	Sample % Passing	Sieve (mm)	Sample % Passing
50.0	100.0	0.0059	56.8
40.0	100.0	0.0043	50.8
25.0	100.0	0.0031	44.8
20.0	100.0	0.0025	42.8
16.0	100.0	0.0013	35.3
12.5	100.0		
9.5	100.0		
4.75	99.2		
2.36	98.4		
2.00	98.2		
1.18	97.1		
0.600	95.6		
0.300	91.2		
0.150	83.7		
0.075	77.3		
0.0302	74.7		
0.0194	70.7		
0.0114	66.8		
0.0081	64.8		
Gravel:	0.8%	D ₁₀ :	-
Sand:	21.8%	D ₃₀ :	-
Silt:	37.2%	D ₆₀ :	0.0068
Clay:	40.1%	C _u :	-
		C _c :	-



—○— % Passing

Comments:

Reviewed by:

Reporting of these test results constitutes a testing service only. Engineering interpretation or evaluation of the test results is provided only on written request. The data presented above is for the sole use of the client stipulated above. Stantec is not responsible, nor can be held liable, for the use of this report by any other party, with or without the knowledge of Stantec.



Grain Size Analysis
 Hydrometer Report
 ASTM D422
 CANFEM

Client: Aurum Industrial Development Partnership
 Project Name: Aurum Road Creek Crossing
 Project No: 123312651.400

OFFICE **LABORATORY**
 10160 - 112 ST 10575 106 ST
 Edmonton, Alberta Edmonton, Alberta
 Canada T5K 2L6 Canada T5H 2X5
 Tel: (780) 917-7000 Tel: (780) 917-7463

SAMPLE No.: BULK
 SOURCE: BH16
 TESTED BY: JA

DATE TESTED: October 14, 2016
 DATE RECEIVED: September 19, 2016
 SAMPLE DESCRIPTION: Silty, sandy clay

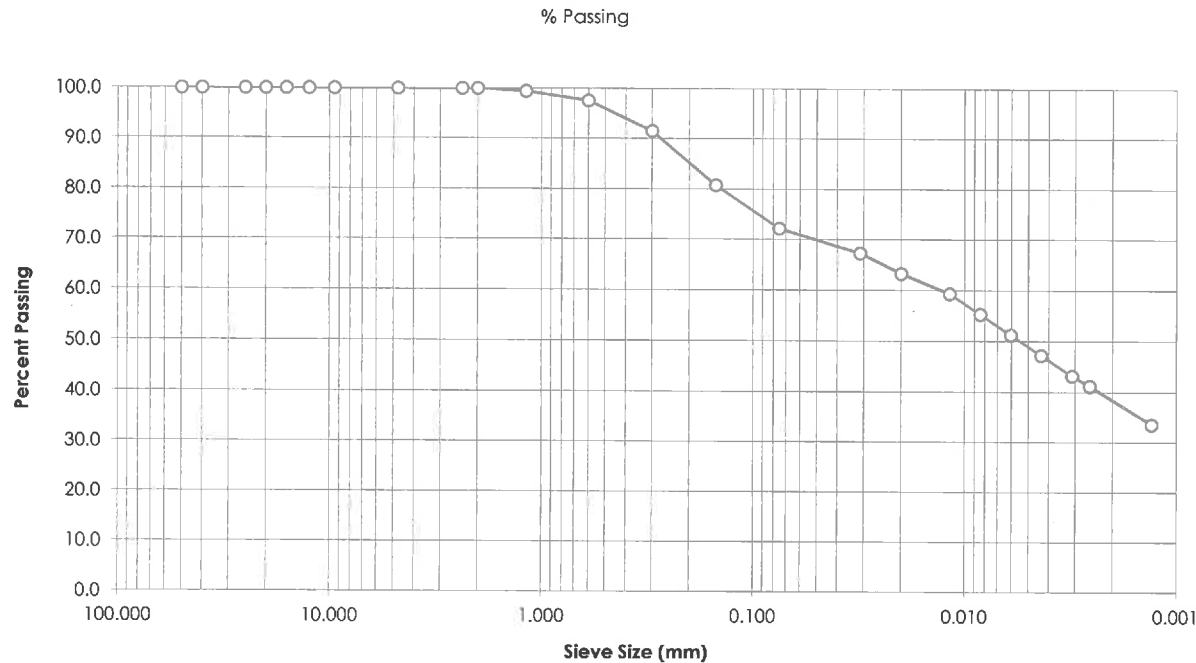

Sieve (mm)	Sample % Passing	Sieve (mm)	Sample % Passing
50.0	100.0	0.0060	51.2
40.0	100.0	0.0043	47.2
25.0	100.0	0.0031	43.2
20.0	100.0	0.0026	41.2
16.0	100.0	0.0013	33.6
12.5	100.0		
9.5	100.0		
4.75	100.0		
2.36	100.0		
2.00	100.0		
1.18	99.4		
0.600	97.6		
0.300	91.5		
0.150	80.8		
0.075	72.1		
0.0311	67.3		
0.0200	63.3		
0.0117	59.3		
0.0084	55.3		
Gravel:	0.0%	D ₁₀ :	-
Sand:	27.9%	D ₃₀ :	-
Silt:	33.7%	D ₆₀ :	0.0133
Clay:	38.4%	C _u :	-
		C _c :	-



—○— % Passing

Comments:

Reviewed by:

Reporting of these test results constitutes a testing service only. Engineering interpretation or evaluation of the test results is provided only on written request. The data presented above is for the sole use of the client stipulated above. Stantec is not responsible, nor can be held liable, for the use of this report by any other party, with or without the knowledge of Stantec.



Grain Size Analysis

Hydrometer Report
 ASTM D422
 CANFEM

Client: Aurum Industrial Development Partnership
 Project Name: Aurum Road Creek Crossing
 Project No: 123312651.400

OFFICE **LABORATORY**
 10160 - 112 ST 10575 106 ST
 Edmonton, Alberta Edmonton, Alberta
 Canada T5K 2L6 Canada T5H 2X5
 Tel: (780) 917-7000 Tel: (780) 917-7463

SAMPLE No.: BULK
 SOURCE: BH17
 TESTED BY: JA

DATE TESTED: October 14, 2016
 DATE RECEIVED: September 19, 2016
 SAMPLE DESCRIPTION: Lean clay with sand

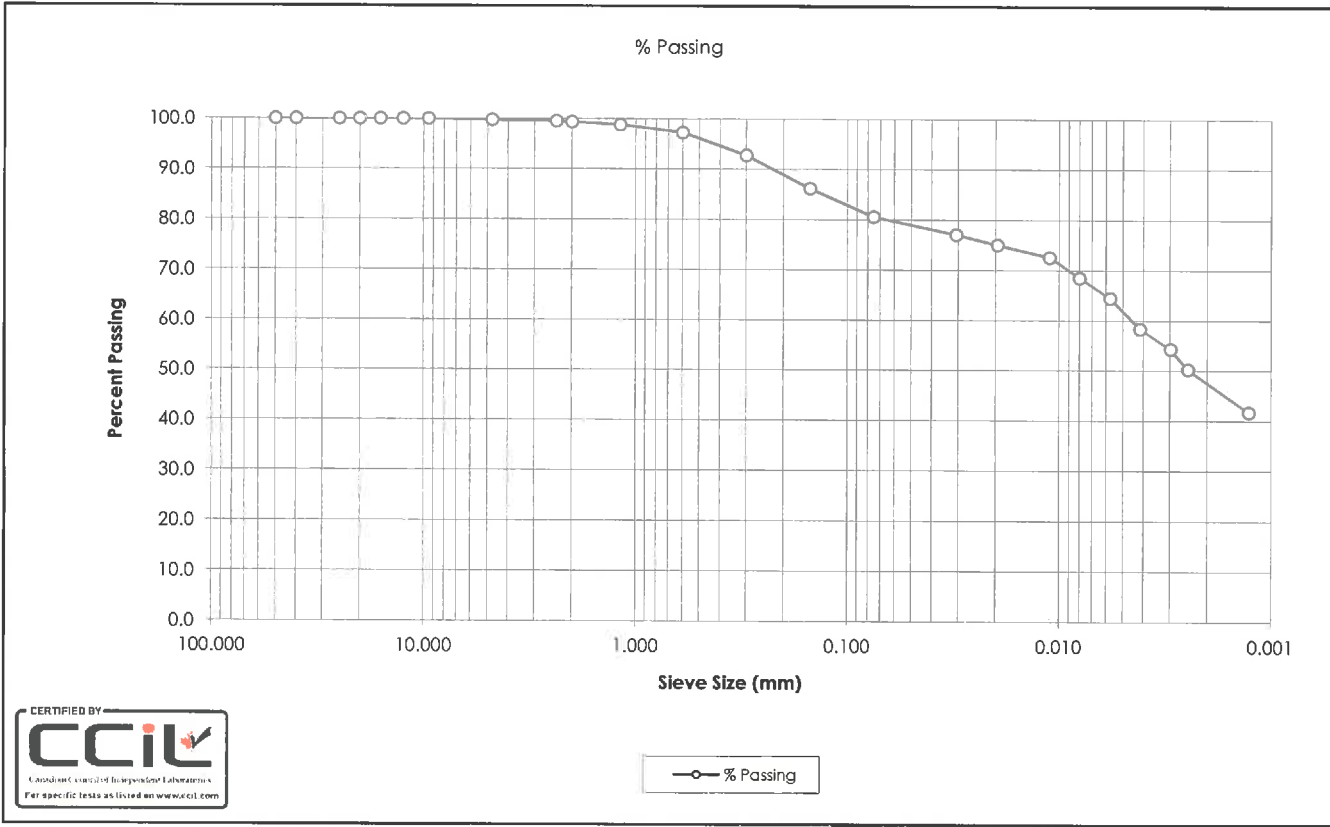

Sieve (mm)	Sample % Passing	Sieve (mm)	Sample % Passing
50.0	100.0	0.0057	64.5
40.0	100.0	0.0042	58.4
25.0	100.0	0.0030	54.3
20.0	100.0	0.0025	50.2
16.0	100.0	0.0013	41.7
12.5	100.0		
9.5	100.0		
4.75	99.8		
2.36	99.5		
2.00	99.4		
1.18	98.8		
0.600	97.2		
0.300	92.7		
0.150	86.2		
0.075	80.6		
0.0306	77.1		
0.0195	75.1		
0.0111	72.6		
0.0080	68.5		
Gravel:	0.2%	D ₁₀ :	-
Sand:	19.2%	D ₃₀ :	-
Silt:	33.0%	D ₆₀ :	0.0046
Clay:	47.6%	C _u :	-
		C _c :	-

Comments:

Reviewed by:

Reporting of these test results constitutes a testing service only. Engineering interpretation or evaluation of the test results is provided only on written request. The data presented above is for the sole use of the client stipulated above. Stantec is not responsible, nor can be held liable, for the use of this report by any other party, with or without the knowledge of Stantec.



Moisture Density Relationship

10575 106 Street
Edmonton, Alberta
T5H 2X5

ASTM Designation: D698

ASTM Designation: D1557

PROJECT: Aurum Road Creek Crossing
CLIENT: Aurum Industrial Development Partnership
PROJECT No.: 123312651.400

DATE SAMPLED: September 19, 2016
DATE RECEIVED: September 19, 2016
SAMPLE No.: BH 1 BULK

TRIAL No.
DRY DENSITY (kg/m³)
MOISTURE CONTENT (%)

1	2	3	4	5
1683	1711	1696	1591	1551
16.4	18.6	19.8	22.9	24.5

Source of Sample: BH1
Soil Description: Clay and silt, tr sand and gravel
Date Tested: October 13, 2016
Maximum Dry Density: 1720kg/m³
Optimum M.C.: 18.0%
Natural M.C.: 14.8%
Oversize Correction: 0.0%

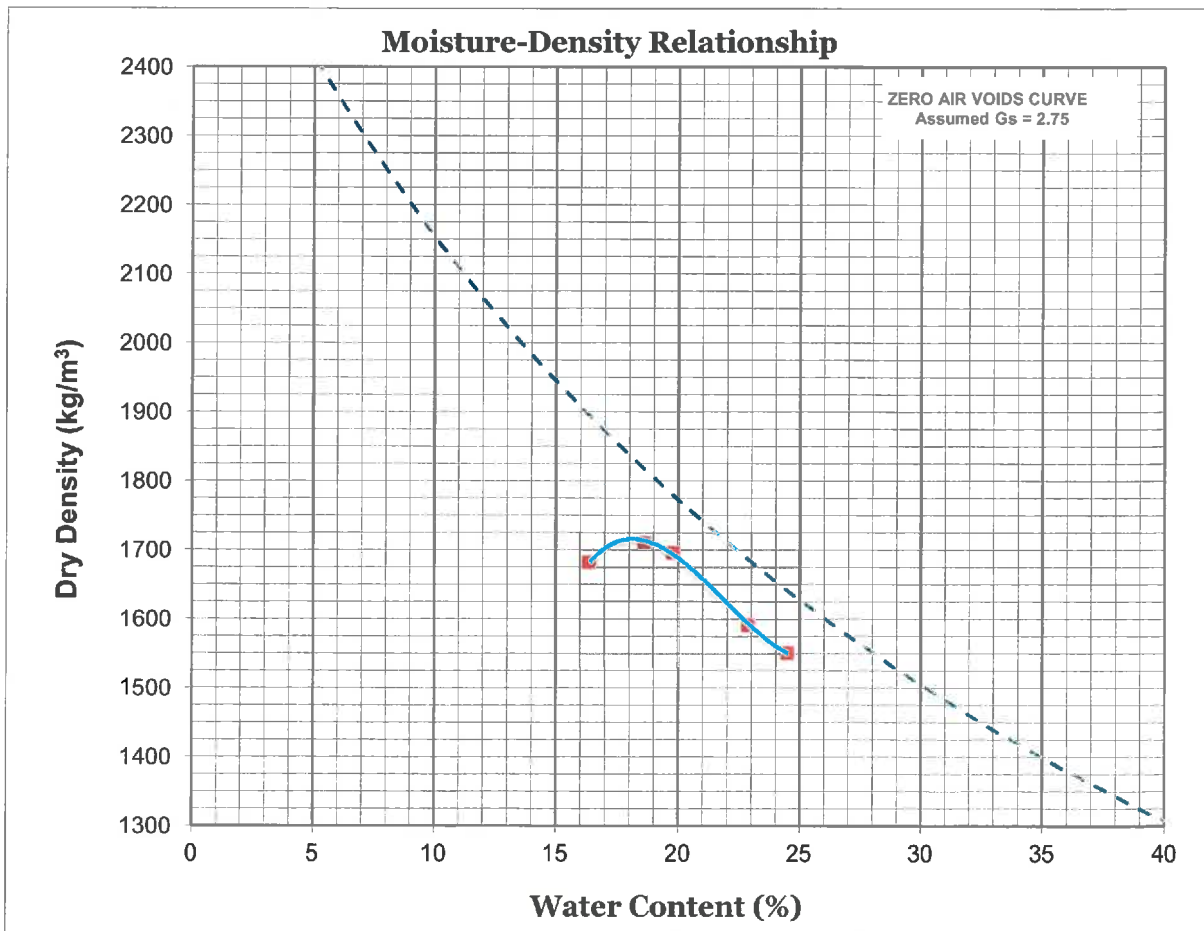

Reviewed By:

Steffen Karl, P.Eng



Moisture Density Relationship

Stantec Consulting Ltd.

10575 106 Street
Edmonton, Alberta

ASTM Designation: D698

ASTM Designation: D1557

T5H 2X5

PROJECT: Aurum Road Creek Crossing
CLIENT: Aurum Industrial Development Partnership
PROJECT No.: 123312651.400

DATE SAMPLED: September 19, 2016
DATE RECEIVED: September 19, 2016
SAMPLE No.: BH 14 BULK

TRIAL No.
DRY DENSITY (kg/m³)
MOISTURE CONTENT (%)

1	2	3	4	5
1542	1656	1628	1582	1515
17.7	20.0	21.9	23.8	25.9

Source of Sample: BH14
Soil Description: Clay and silt, tr sand and gravel
Date Tested: October 11, 2016
Maximum Dry Density: 1655kg/m³
Optimum M.C.: 20.5%
Natural M.C.: 19.8%
Oversize Correction: 0.0%

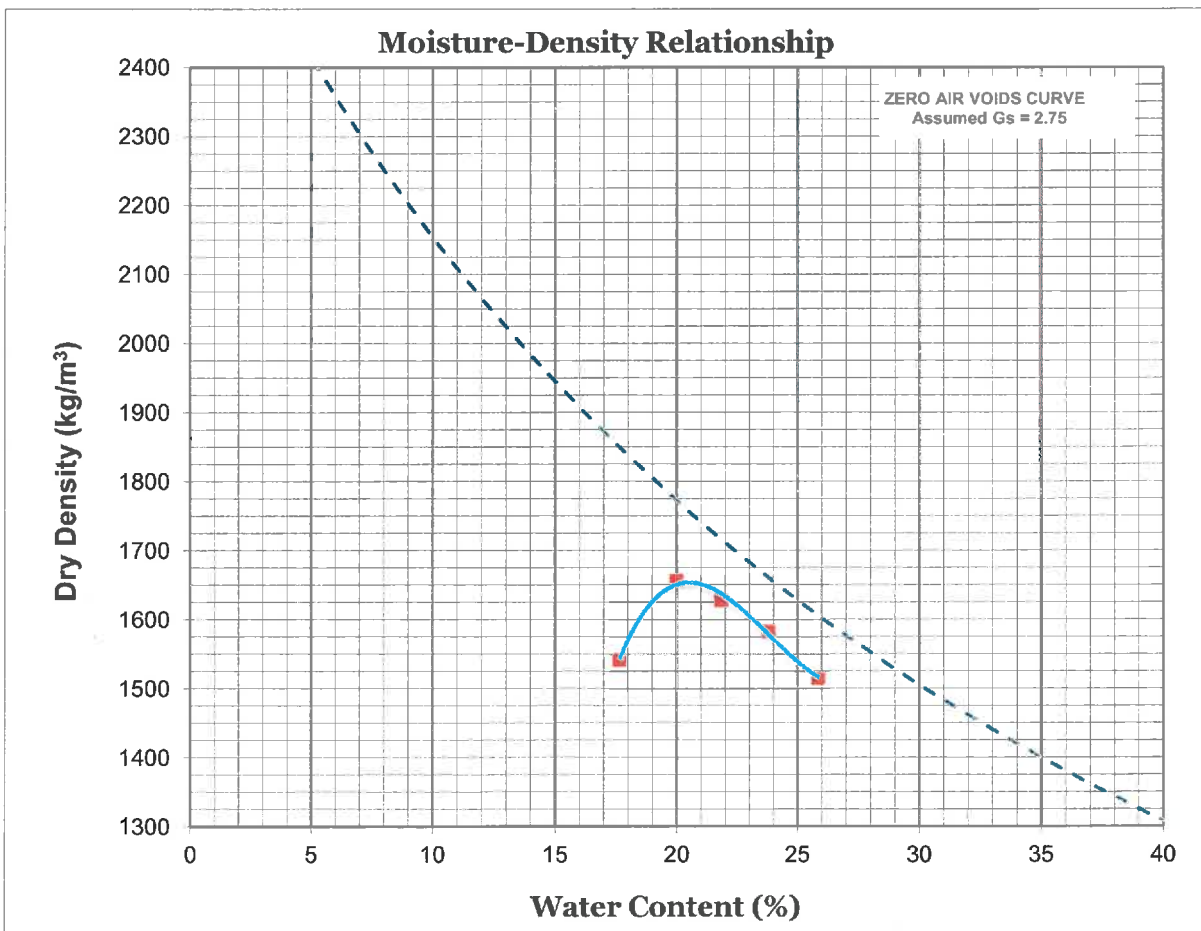

Reviewed By:

Steffen Karl, P.Eng



Moisture Density Relationship

10575 106 Street
Edmonton, Alberta

ASTM Designation: D698

ASTM Designation: D1557

T5H 2X5

PROJECT: Aurum Road Creek Crossing
CLIENT: Aurum Industrial Development Partnership
PROJECT No.: 123312651.400

DATE SAMPLED: September 19, 2016
DATE RECEIVED: September 19, 2016
SAMPLE No.: BH 16 BULK

TRIAL No.
DRY DENSITY (kg/m³)
MOISTURE CONTENT (%)

1	2	3	4	5
1621	1645	1612	1506	1525
17.8	20.2	21.7	27.1	26.3

Source of Sample: BH16
Soil Description: Clay and silt, tr sand and gravel
Date Tested: October 13, 2016
Maximum Dry Density: 1640kg/m³
Optimum M.C.: 19.5%
Natural M.C.: 13.3%
Oversize Correction: 0.0%

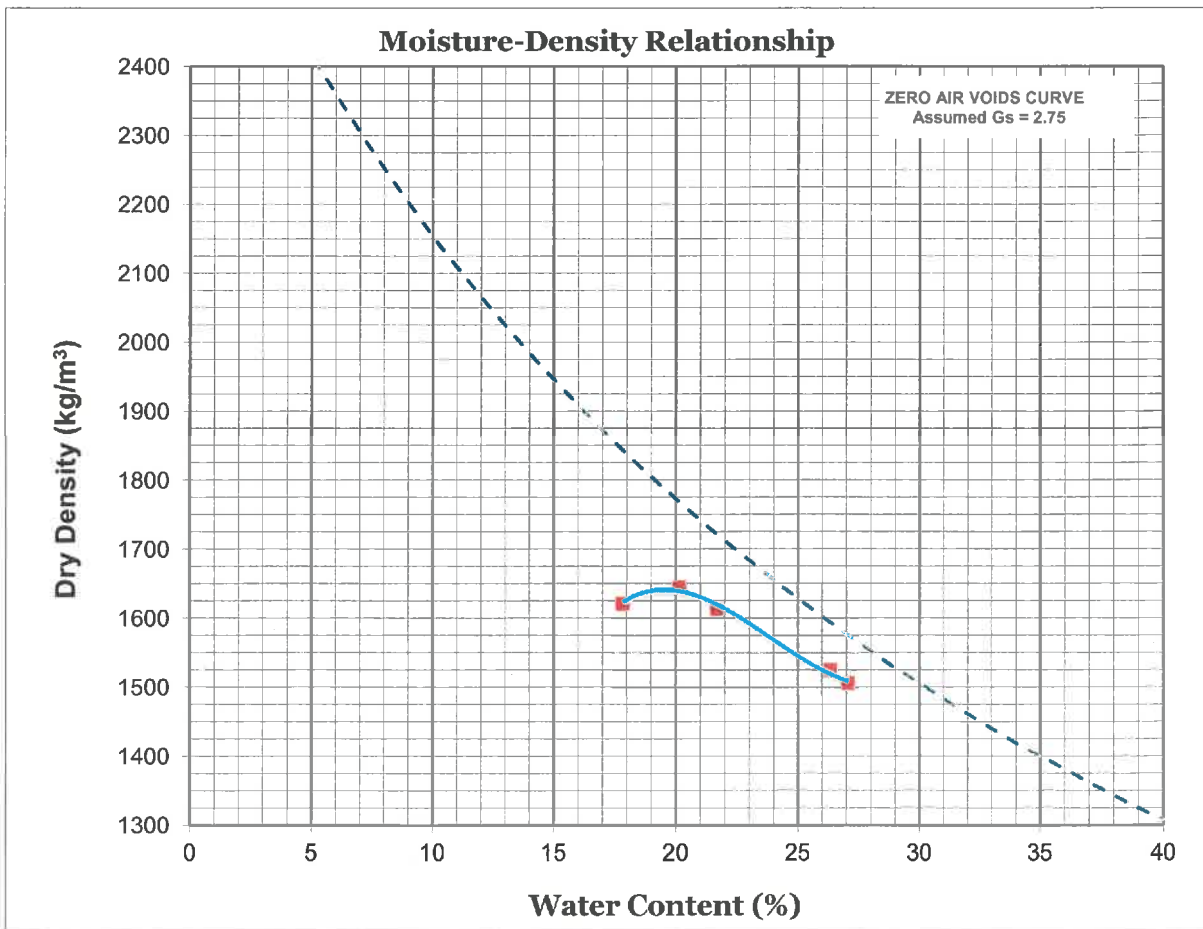

Reviewed By:

Steffen Karl, P.Eng



Moisture Density Relationship

10575 106 Street
Edmonton, Alberta
T5H 2X5

ASTM Designation: D698

ASTM Designation: D1557

PROJECT: Aurum Road Creek Crossing
CLIENT: Aurum Industrial Development Partnership
PROJECT No.: 123312651.400

DATE SAMPLED: September 19, 2016
DATE RECEIVED: September 19, 2016
SAMPLE No.: BH 17 BULK

TRIAL No.
DRY DENSITY (kg/m³)
MOISTURE CONTENT (%)

1	2	3	4	5
1616	1642	1603	1577	1552
16.4	18.4	20.7	23.1	25.3

Source of Sample: BH17
Soil Description: Clay and silt, tr sand and gravel
Date Tested: October 13, 2016
Maximum Dry Density: 1640kg/m³
Optimum M.C. 18.5%
Natural M.C. 17.3%
Oversize Correction 0.0%

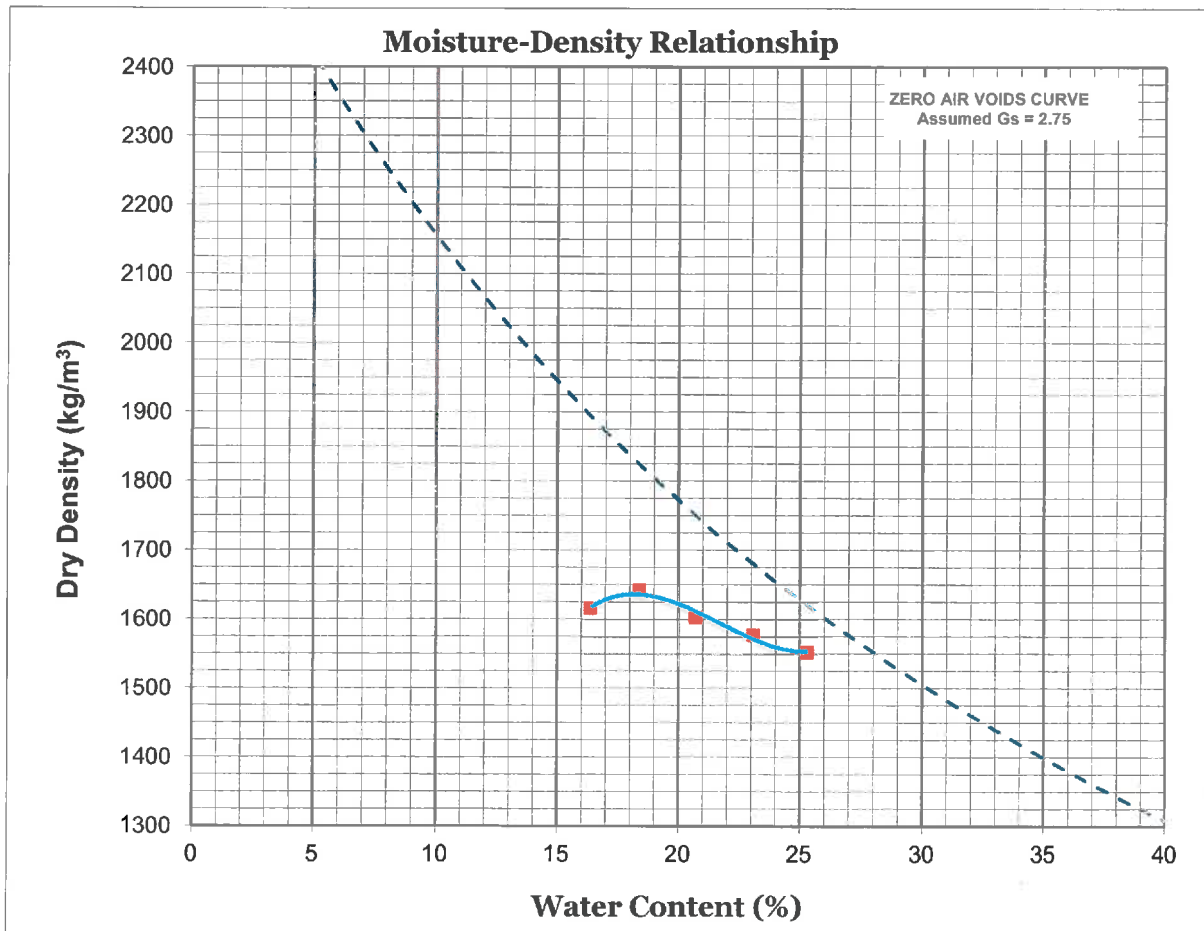

Reviewed By:

Steffen Karl, P.Eng

Stantec Consulting Ltd.
California Bearing Ratio Test Report

Date 10/24/16

Checked By .S JC

Date 10/18/2016

Computed By JA

Date 10/17/2016

Tested By JA

Load Penetration Curve

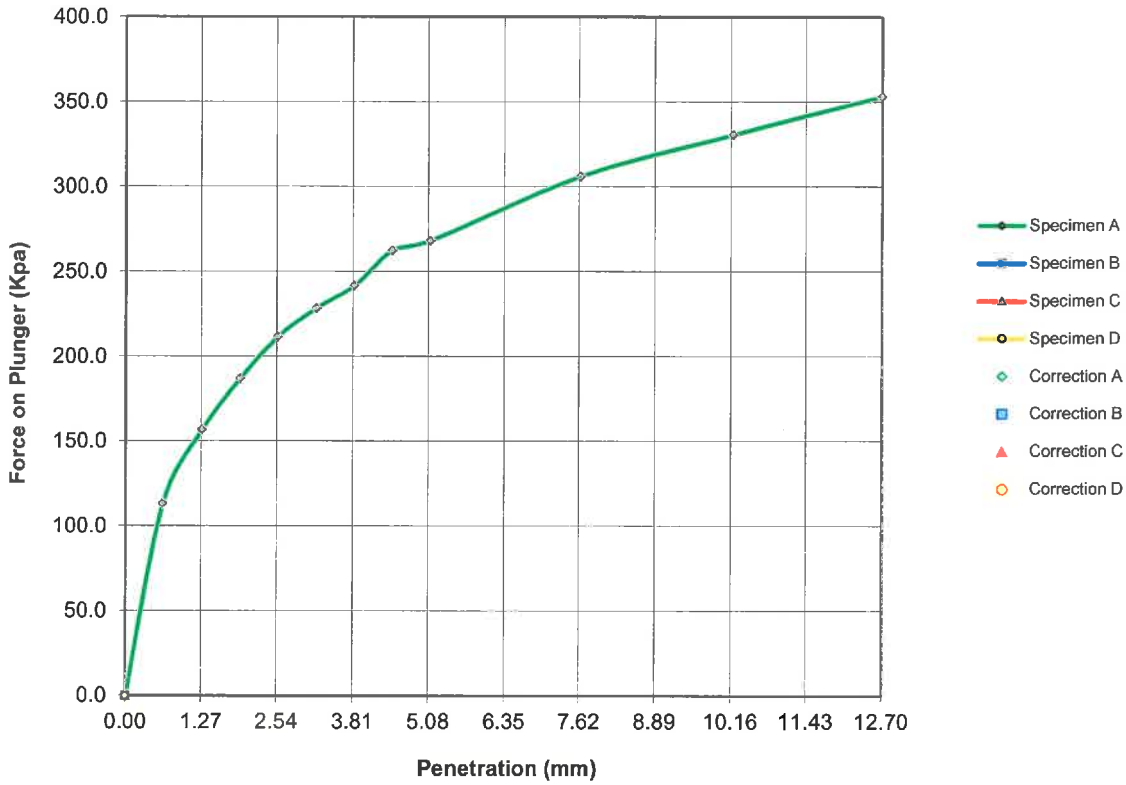

CBR Results					
Results	A	B	C	D	Average
2.54 mm Pen.	3.1				3.1
5.08 mm Pen.	2.6				2.6
Moisture (%)	19.86				19.86
Density (g/cm3)	1.626				1.626
Final Moisture (%)	23.7				23.70
Final Density (g/cm3)	1.601				1.601

Project Information			
Project Num	123312651.400	Sample Location	
Project	Aurum Road Creek Crossing	Specimen A	
Date	October 17, 2016	Specimen B	
Client	Aurum Industrial Development Partnership	Specimen C	
		Specimen D	
Test Variables			
Job Ref.		Liquid Limit:	
Sample Num.	BH14 BULK	Plastic Limit:	
Remarks			



Edmonton Laboratory
 10575-106 Street
 Edmonton, AB T5H 2X5
 Ph: 780-917-7000
 Fax: 780-917-7269

UNIT WEIGHTS - SPT SAMPLES

Project No.: 123312651.400

Date: November 2, 2016

Project: Aurum Road Creek Crossing

Technician: JA

Test Hole Number	Sample Number	Depth (m)	Moisture Content (%)	Wet Density (kg/m³)	Dry Density (kg/m³)	Total Unit Weight (kN/m³)
BH6	RC5	18.9 - 19.1M	13	1973	1747	19
BH6	RC9	24.7M	16	2071	1786	20

Reviewed By: 



Stantec

**Shelby Tube
Report**

Project No.: 123312651

Project Name: Aurum Road Creek Crossing

Date: October 28, 2016

Sample No.: BH6 RC9 Depth: 24.7M

Tester: JA

Pre-Extrusion

INSIDE DIAMETER OF TUBE	A	6.26	cm	Tests Performed: Unconfined test, atterberg limits, moisture, hydrometer
AREA	B	36.81	cm ²	
OUTSIDE LENGTH	C	113.00	cm	
TOP RUNOUT	D	0.00	cm	
BOT. RUNOUT	E	0.00	cm	
LENGTH OF SAMPLE	F	113.00	cm	
VOLUME OF SAMPLE	G	348.58	cm ³	
WEIGHT OF SOIL AND TUBE	H	756.2	g	
WEIGHT OF TUBE	I	0.0	g	
WEIGHT OF SOIL	J	756.2	g	

Post-Extrusion

Shelby Tube Condition	NA		POST Extrusion Length of Sample
Pocket Pen Value (kg/cm ²)			
Sample Description	Clay shale		
Remarks	Rock core, no extrusion required		

		Moisture Content		Moisture Content	
WET WEIGHT OF SOIL & TARE	K	769.5	g	769.5	g
DRY WEIGHT OF SOIL & TARE	L	666.1	g	666.1	g
WEIGHT OF WATER	M	103.4	g	103.4	g
WEIGHT OF DRY SOIL	N	650.1	g	650.1	g
TARE NO & TARE WEIGHT	O	16.0	g	16.0	g
MOISTURE CONTENT (M/N) X 100		15.90	%	15.90	%
AVERAGE MOISTURE CONTENT	P	15.90	%		
DENSITY (J/G)	Q	2.169	g/cm ³		
WET DENSITY (Q X 1000)	R	2169	kg/m ³		
DRY DENSITY R / (1 + P)	S	1872	kg/m ³		

Visual Description

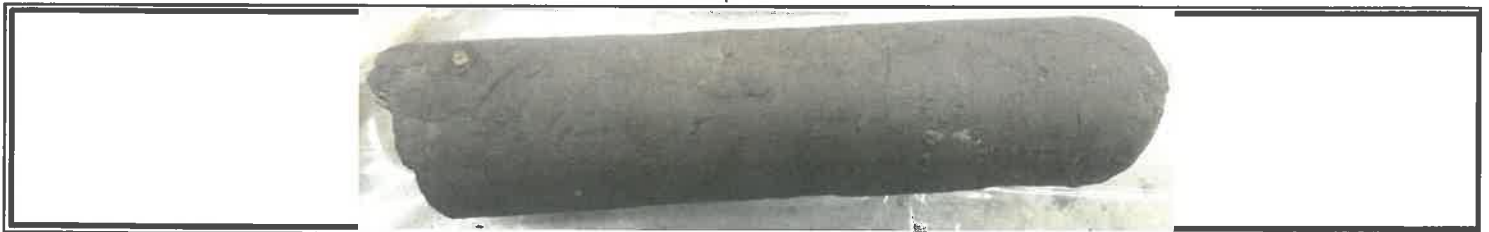

TOP

BOTTOM



Stantec

**Shelby Tube
Report**

Project No.: 123312651

Project Name: Aurum Road Creek Crossing

Date: October 28, 2016

Sample No.: BH6 ST5

Depth: 3.1M-3.5M

Tester: JA

Pre-Extrusion

INSIDE DIAMETER OF TUBE	A	7.35	cm	Tests Performed: Unconfined test, atterberg limits, moisture, water soluble sulphate CSA, chlorides, Ph - soil, and resistivity/conductivity
AREA	B	42.40	cm ²	
OUTSIDE LENGTH	C	52.60	cm	
TOP RUNOUT	D	29.90	cm	
BOT. RUNOUT	E	0.00	cm	
LENGTH OF SAMPLE	F	22.70	cm	
VOLUME OF SAMPLE	G	962.48	cm ³	
WEIGHT OF SOIL AND TUBE	H	3306.8	g	
WEIGHT OF TUBE	I	1480.6	g	
WEIGHT OF SOIL	J	1826.2	g	

Post-Extrusion

Shelby Tube Condition	SHELBY TUBE DEFORMED, CUT OFF THE DEFORMED PORTION		POST Extrusion Length of Sample
Pocket Pen Value (kg/cm ²)			
Sample Description	TILL - Clay and silt, tr sand and gravel, oxidize		
Remarks			

		Moisture Content		Moisture Content	
WET WEIGHT OF SOIL & TARE	K	1476.5	g	1476.5	g
DRY WEIGHT OF SOIL & TARE	L	1276.5	g	1276.5	g
WEIGHT OF WATER	M	200.0	g	200.0	g
WEIGHT OF DRY SOIL	N	1042.7	g	1042.7	g
TARE NO & TARE WEIGHT	O	233.8	g	233.8	g
MOISTURE CONTENT (M/N) X 100		19.18	%	19.18	%
AVERAGE MOISTURE CONTENT	P	19.18	%		
DENSITY (J/G)	Q	1.897	g/cm ³		
WET DENSITY (Q X 1000)	R	1897	kg/m ³		
DRY DENSITY R / (1 + P)	S	1592	kg/m ³		

Visual Description

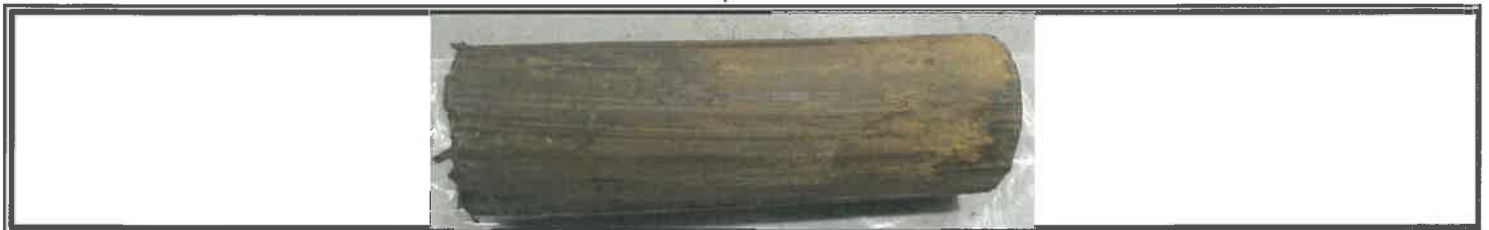

TOP

BOTTOM

Stantec Consulting Ltd.
Unconfined Compression Test Report (ASTM D2166)

Date 11/8/16

Checked By [Signature]

Date 10/31/2016

Date

Computed By JA

Date 10/31/2016

Date

Tested By JA

Compressive Stress Axial Strain Curve

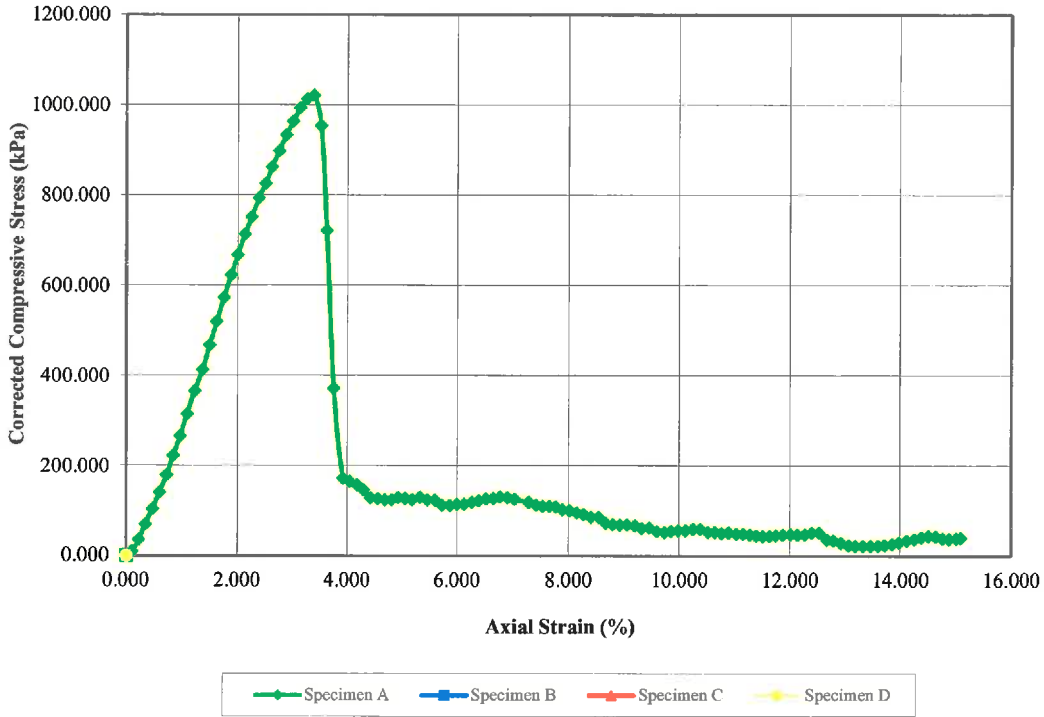

Before Test	Specimen			
	A	B	C	D
Water Content (%)	16.41			
Dry Density (g/cm ³)	1.818			
Saturation (%)	94.98			
Void Ratio	0.46			
Diameter (mm)	60.940			
Height (mm)	130.430			
Test Data	A	B	C	D
Unconfined Strength (kPa)	1021.464			
Undrained Shear Strength (kgf/cm ²)	5.208			
Undrained Shear Strength (kPa)	510.732			
Rate of Strain (mm/min)	2.000000			
Strain at Failure (%)	3.38			
Project Information		Specimen Description		
Project Num	123312651.400	Specimen A	Clay Shale	
Project	Aurum Road Creek Crossing	Specimen B		
Sampling Date	September 8, 2016	Specimen C		
Sample #	BH2 RC4 - 11.97M	Specimen D		
Client	Aurum Industrial Development Partnership	Test Variables		
		Specific Gravity	2.65	
		Liquid Limit:		
		Plastic Limit:		
Remarks				

Stantec Consulting Ltd.
Unconfined Compression Test Report (ASTM D2166)

Date 11/8/16

Checked By JS

Date 11/3/2016

Computed By JA

Date 10/31/2016

Tested By JA

Compressive Stress Axial Strain Curve

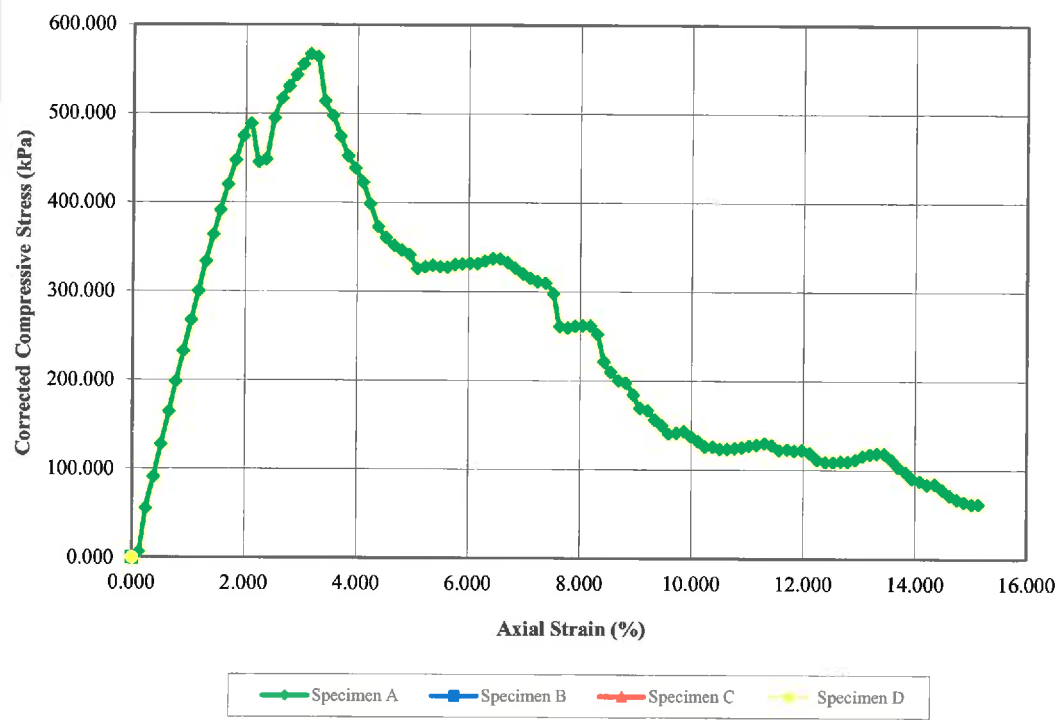

Before Test	Specimen			
	A	B	C	D
Water Content (%)	12.91			
Dry Density (g/cm ³)	1.941			
Saturation (%)	93.68			
Void Ratio	0.37			
Diameter (mm)	61.400			
Height (mm)	126.267			
Test Data	A	B	C	D
Unconfined Strength (kPa)	567.116			
Undrained Shear Strength (kgf/cm ²)	2.891			
Undrained Shear Strength (kPa)	283.558			
Rate of Strain (mm/min)	2.000000			
Strain at Failure (%)	3.15			
Description		Project Information		
Project Num	123312651.400	Specimen A	Clay Shale	
Project	Aurum Road Creek Crossing	Specimen B		
Sampling Date	September 16, 2016	Specimen C		
Sample #	BH6 RC5 18.9M	Specimen D		
Client	Aurum Industrial Development Partnership	Test Variables		
		Specific Gravity	2.65	
		Liquid Limit:		
		Plastic Limit:		
Remarks				

Stantec Consulting Ltd.
Unconfined Compression Test Report (ASTM D2166)

Date 11/8/16

Checked By *SR*

11/3/2016

Date

Computed By JA

Date 10/31/2016

Tested By JA

Compressive Stress Axial Strain Curve

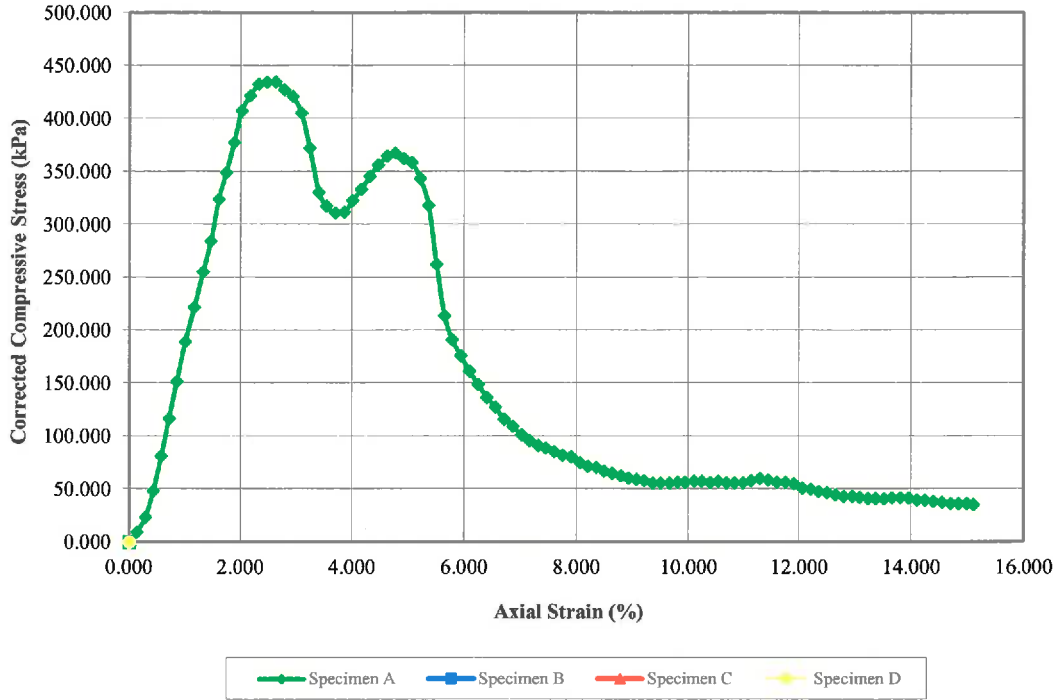

Before Test	Specimen			
	A	B	C	D
Water Content (%)	15.91			
Dry Density (g/cm ³)	1.874			
Saturation (%)	97.44			
Void Ratio	0.44			
Diameter (mm)	62.633			
Height (mm)	113.000			
Test Data	A	B	C	D
Unconfined Strength (kPa)	434.651			
Undrained Shear Strength (kgf/cm ²)	2.216			
Undrained Shear Strength (kPa)	217.326			
Rate of Strain (mm/min)	2.000000			
Strain at Failure (%)	2.63			

Description		Specimen Description	
Project Num	123312651.400	Specimen A	Clay Shale
Project	Aurum Road Creek Crossing	Specimen B	
Sampling Date	September 16, 2016	Specimen C	
Sample #	BH6 RC9 24.7M	Specimen D	
Client	Aurum Industrial Development Partnership	Test Variables	
		Specific Gravity	2.70
		Liquid Limit:	
		Plastic Limit:	

Remarks

Stantec Consulting Ltd.
Unconfined Compression Test Report (ASTM D2166)

Date 11/8/16

Checked By *JS*

Date 11/3/2016

Computed By JA

Date 10/31/2016

Tested By JA

Compressive Stress Axial Strain Curve

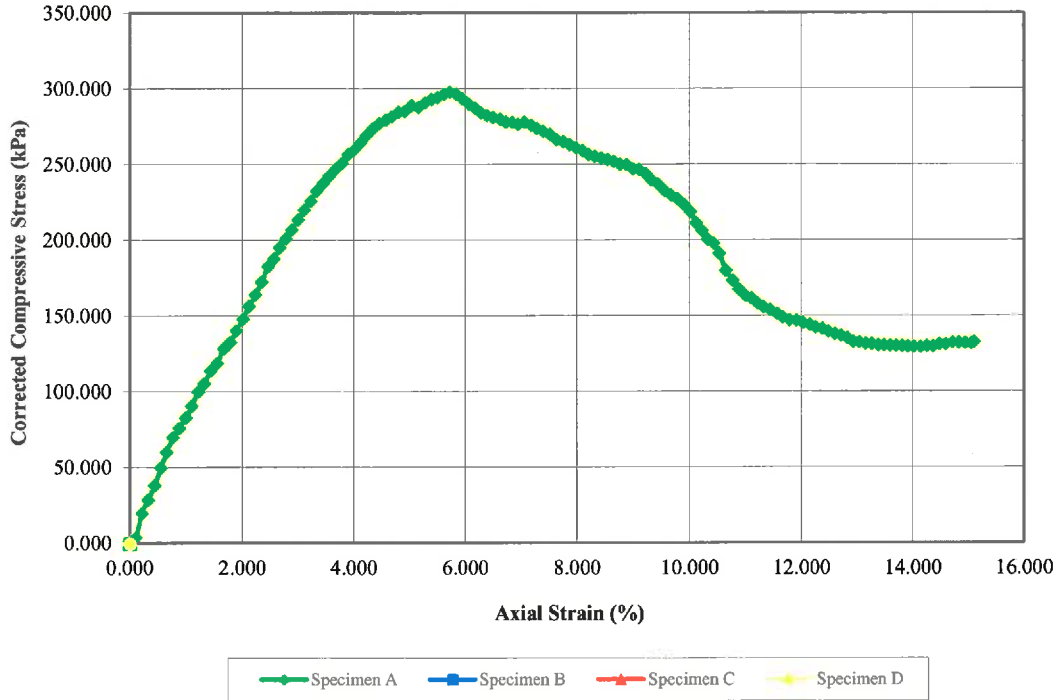

Before Test	Specimen			
	A	B	C	D
Water Content (%)	19.18			
Dry Density (g/cm ³)	1.697			
Saturation (%)	90.55			
Void Ratio	0.56			
Diameter (mm)	72.547			
Height (mm)	148.930			
Test Data	A	B	C	D
Unconfined Strength (kPa)	297.854			
Undrained Shear Strength (kgf/cm ²)	1.519			
Undrained Shear Strength (kPa)	148.927			
Rate of Strain (mm/min)	2.000000			
Strain at Failure (%)	5.72			
Description		Specimen Description		
Project Num	123312651.400	Specimen A	Clay and silt, tr sand and gravel, oxidize	
Project	Aurum Road Creek Crossng	Specimen B		
Sampling Date	September 16, 2016	Specimen C		
Sample #	BH6 ST5 3.1M - 3.5M	Specimen D		
Client	Aurum Industrial Development Partnership	Test Variables		
		Specific Gravity	2.65	
		Liquid Limit:		
		Plastic Limit:		
Remarks				

Stantec Consulting Ltd.
Unconfined Compression Test Report (ASTM D2166)

Date 11/8/16

Checked By SX

Date 11/3/2016

Computed By JA

Date 10/31/2016

Tested By JA

Compressive Stress Axial Strain Curve

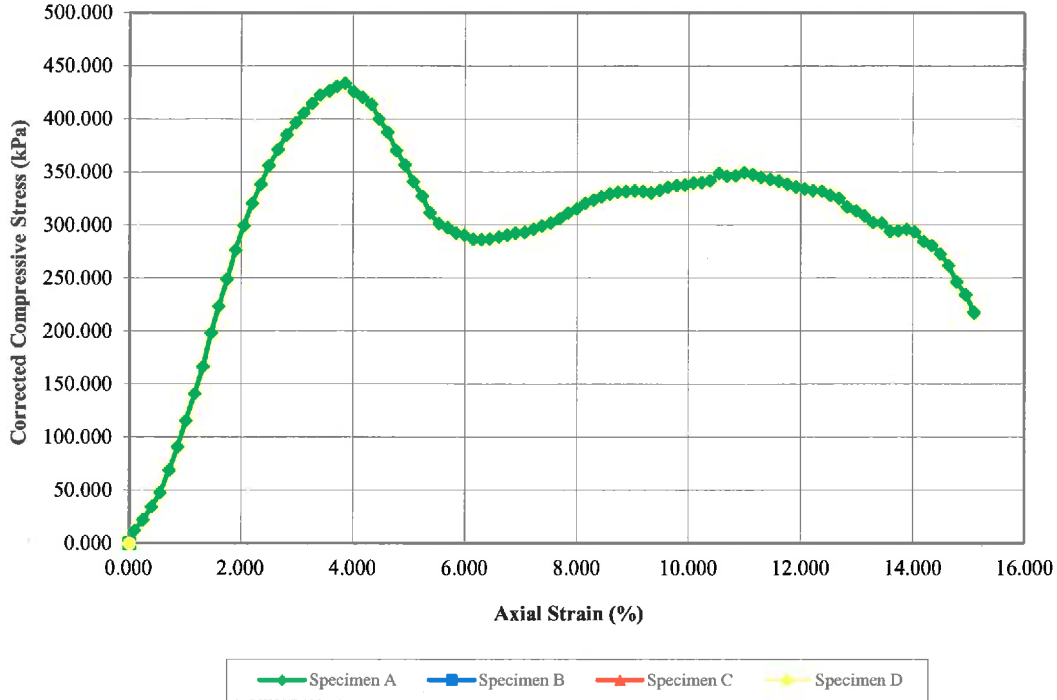

Before Test	Specimen			
	A	B	C	D
Water Content (%)	15.63			
Dry Density (g/cm ³)	1.862			
Saturation (%)	97.79			
Void Ratio	0.42			
Diameter (mm)	61.210			
Height (mm)	110.737			
Test Data	A	B	C	D
Unconfined Strength (kPa)	433.857			
Undrained Shear Strength (kgf/cm ²)	2.212			
Undrained Shear Strength (kPa)	216.929			
Rate of Strain (mm/min)	2.000000			
Strain at Failure (%)	3.85			
Description		Specimen Description		
Project Num	123312651.400	Specimen A	Clay Shale	
Project	Aurum Road Creek Crossing	Specimen B		
Sampling Date	September-16	Specimen C		
Sample #	BH9 RC2 5.76M	Specimen D		
Client	Aurum Industrial Development Partnership	Test Variables		
		Specific Gravity	2.65	
		Liquid Limit:		
		Plastic Limit:		
Remarks				

Stantec Consulting Ltd.
Unconfined Compression Test Report (ASTM D2166)

Date 11/8/16

Checked By *FX*

Date 11/3/2016

Computed By JA

Date 10/31/2016

Tested By JA

Compressive Stress Axial Strain Curve

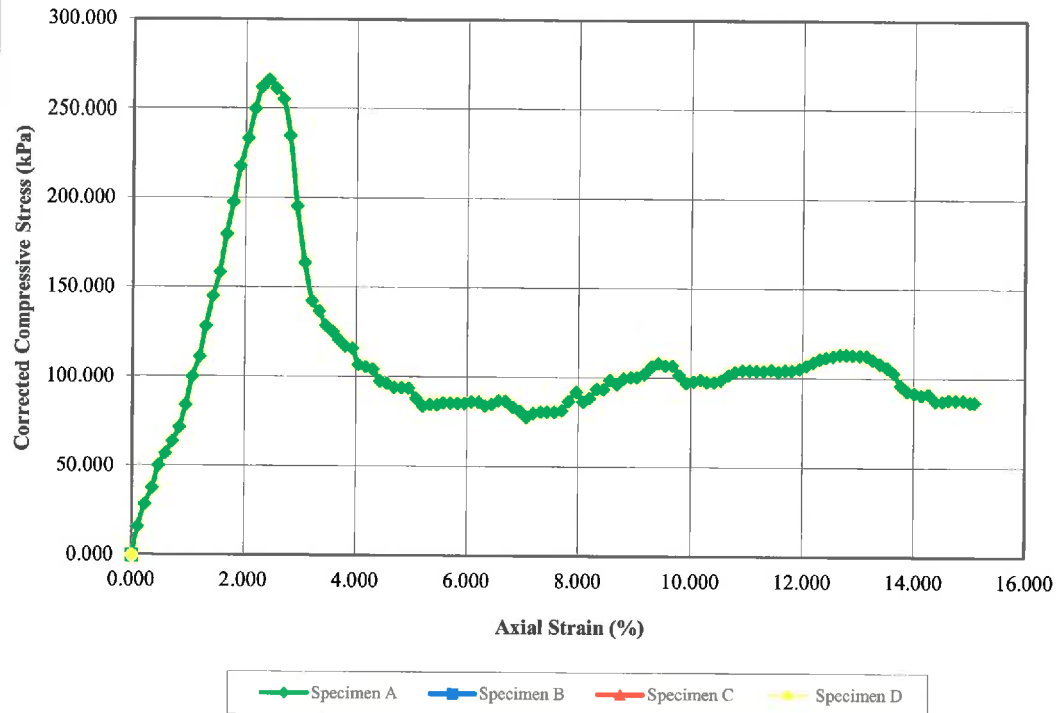

Before Test	Specimen			
	A	B	C	D
Water Content (%)	21.44			
Dry Density (g/cm ³)	1.636			
Saturation (%)	91.72			
Void Ratio	0.62			
Diameter (mm)	63.600			
Height (mm)	135.307			
Test Data	A	B	C	D
Unconfined Strength (kPa)	266.296			
Undrained Shear Strength (kgf/cm ²)	1.358			
Undrained Shear Strength (kPa)	133.148			
Rate of Strain (mm/min)	2.000000			
Strain at Failure (%)	2.41			
Description				
Project Information		Specimen Description		
Project Num	123312651.400	Specimen A	Clay Shale	
Project	Aurum Road Creek Crossing	Specimen B		
Sampling Date	September 15, 2016	Specimen C		
Sample #	BH9 RC9 17.1M	Specimen D		
Client	Aurum Industrial Development Partnership	Test Variables		
		Specific Gravity	2.65	
		Liquid Limit:		
		Plastic Limit:		
Remarks				

Stantec Consulting Ltd.
Unconfined Compression Test Report (ASTM D2166)

Date 11/8/16

Checked By SK

Date 11/3/2016

Computed By JA

Date 10/31/2016

Tested By JA

Compressive Stress Axial Strain Curve

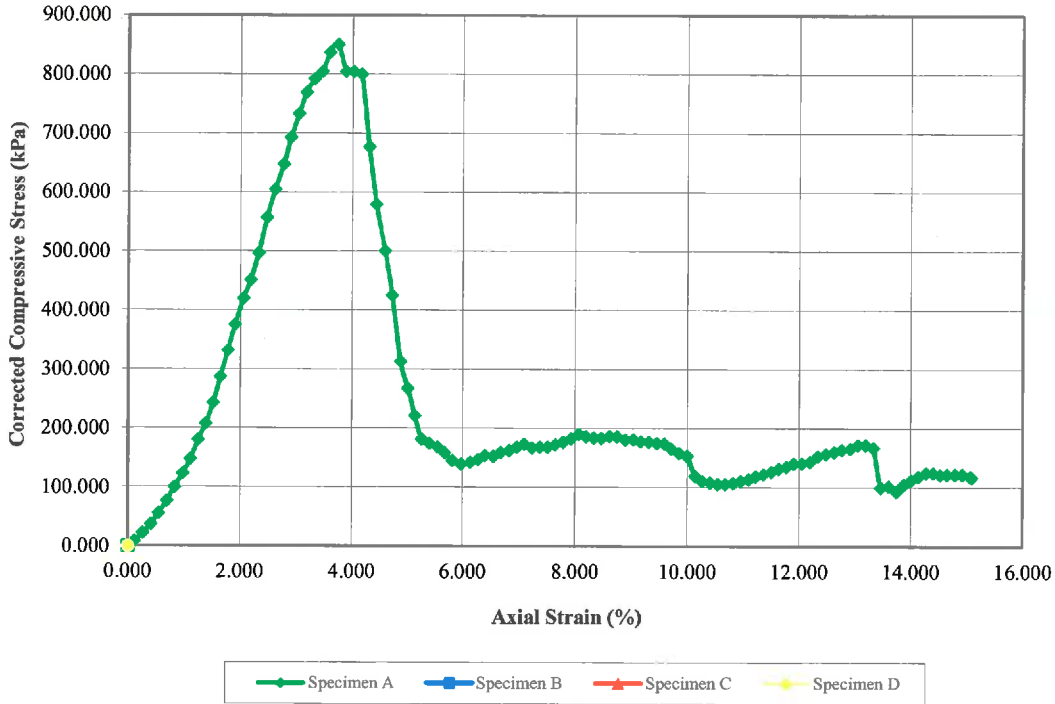

Before Test	Specimen				
	A	B	C	D	
Water Content (%)	17.84				
Dry Density (g/cm ³)	1.776				
Saturation (%)	96.02				
Void Ratio	0.49				
Diameter (mm)	61.060				
Height (mm)	121.293				
Test Data	A	B	C	D	
Unconfined Strength (kPa)	851.422				
Undrained Shear Strength (kgf/cm ²)	4.341				
Undrained Shear Strength (kPa)	425.711				
Rate of Strain (mm/min)	2.000000				
Strain at Failure (%)	3.73				
Description		Project Information		Specimen Description	
Project Num	123312651.400	Specimen A		CLay Shale	
Project	Aurum Road Creek Crossing	Specimen B			
Sampling Date	September 12, 2016	Specimen C			
Sample #	BH10 RC6 12.3M	Specimen D			
Client	Aurum Industrial Development Partnership	Test Variables			
		Specific Gravity	2.65		
		Liquid Limit:			
		Plastic Limit:			
Remarks					

Date 11/8/16

Checked By [Signature]

Date 11/3/2016

Computed By JA

Date 10/31/2016

Tested By JA

Compressive Stress Axial Strain Curve

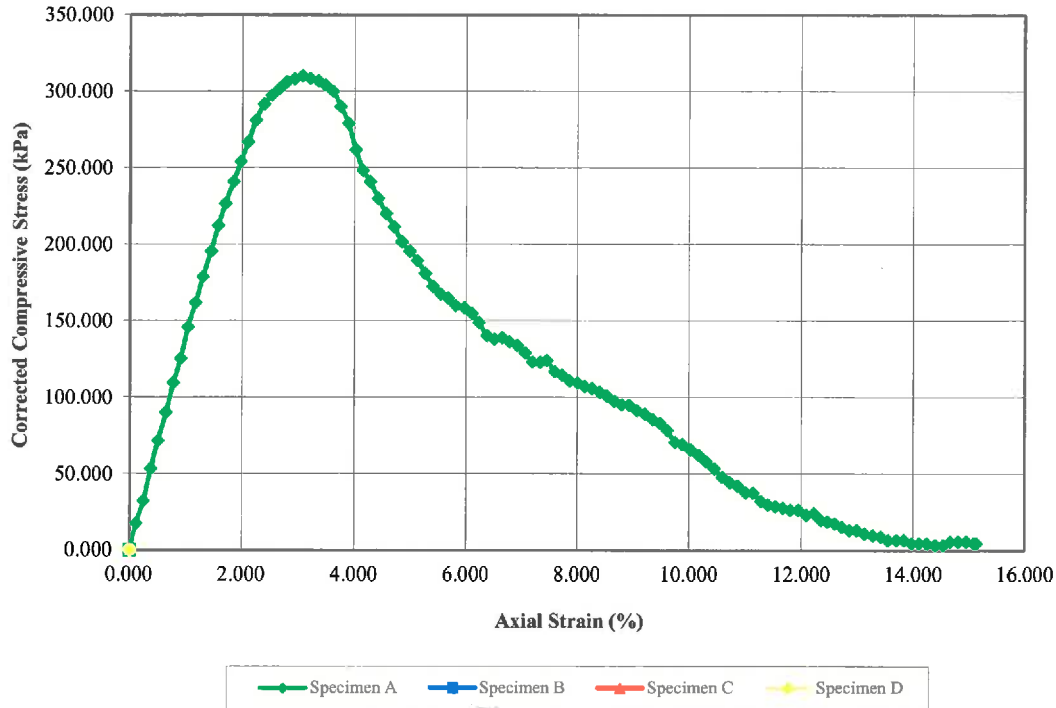

Before Test	Specimen			
	A	B	C	D
Water Content (%)	16.02			
Dry Density (g/cm ³)	1.879			
Saturation (%)	103.52			
Void Ratio	0.41			
Diameter (mm)	61.300			
Height (mm)	123.733			
Test Data	A	B	C	D
Unconfined Strength (kPa)	309.961			
Undrained Shear Strength (kgf/cm ²)	1.580			
Undrained Shear Strength (kPa)	154.981			
Rate of Strain (mm/min)	2.000000			
Strain at Failure (%)	3.07			
Description		Specimen Description		
Project Num	123312651.400	Specimen A	Clay Shale	
Project	Aurum Road Creek Crossing	Specimen B		
Sampling Date	7-Sep-16	Specimen C		
Sample #	BH12 RC4 9.3M	Specimen D		
Client	Aurum Industrial Development Partnership	Test Variables		
		Specific Gravity	2.65	
		Liquid Limit:		
		Plastic Limit:		
Remarks				

Stantec Consulting Ltd.
Unconfined Compression Test Report (ASTM D2166)

Date 11/8/16

Checked By JJC

Date 11/3/2016

Computed By JA

Date 10/31/2016

Tested By JA

Compressive Stress Axial Strain Curve

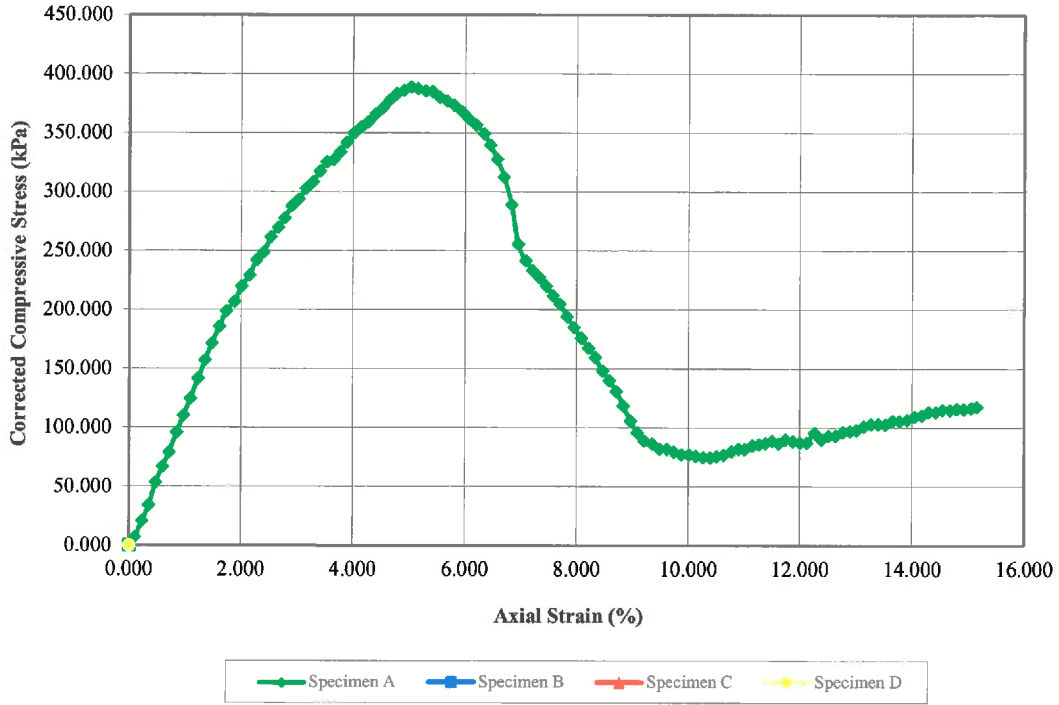

Before Test	Specimen			
	A	B	C	D
Water Content (%)	17.47			
Dry Density (g/cm ³)	1.821			
Saturation (%)	97.78			
Void Ratio	0.48			
Diameter (mm)	61.653			
Height (mm)	132.717			
Test Data	A	B	C	D
Unconfined Strength (kPa)	388.673			
Undrained Shear Strength (kgf/cm ²)	1.982			
Undrained Shear Strength (kPa)	194.336			
Rate of Strain (mm/min)	2.000000			
Strain at Failure (%)	5.03			

Project Information		Specimen Description	
Project Num	123312651.400	Specimen A	Silt stone, coal pieces
Project	Aurum Road Creek Crossing	Specimen B	
Sampling Date	September 13, 2016	Specimen C	
Sample #	BH13 RC1 6.35M	Specimen D	
Client	Aurum Industrial Development Partnership	Test Variables	
		Specific Gravity	2.70
		Liquid Limit:	
		Plastic Limit:	

Remarks

Stantec Consulting Ltd.
Unconfined Compression Test Report (ASTM D2166)

Date 11/8/16

Checked By *SPC*

Date 11/3/2016

Computed By JA

Date 10/31/2016

Tested By JA

Compressive Stress Axial Strain Curve

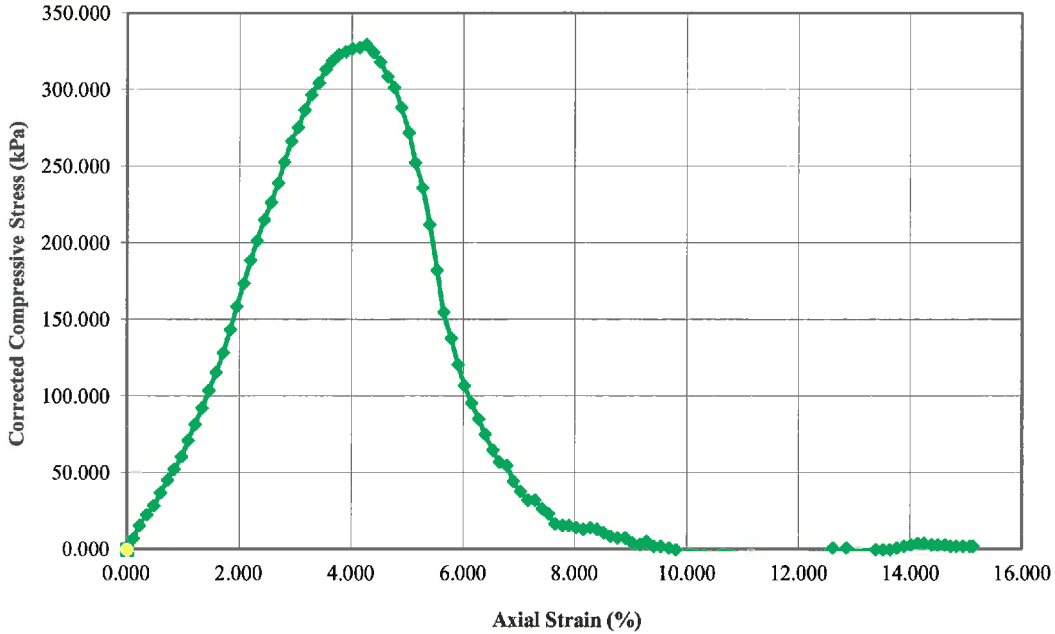

◆ Specimen A
 ◆ Specimen B
 ◆ Specimen C
 ◆ Specimen D

Before Test	Specimen			
	A	B	C	D
Water Content (%)	20.19			
Dry Density (g/cm ³)	1.702			
Saturation (%)	96.05			
Void Ratio	0.56			
Diameter (mm)	62.313			
Height (mm)	135.600			
Test Data	A	B	C	D
Unconfined Strength (kPa)	329.593			
Undrained Shear Strength (kgf/cm ²)	1.680			
Undrained Shear Strength (kPa)	164.796			
Rate of Strain (mm/min)	2.000000			
Strain at Failure (%)	4.26			

Project Information		Specimen Description	
Project Num	123312651.400	Specimen A	Clay Shale
Project	Aurum Road Creek Crossing	Specimen B	
Sampling Date	18-Sep-16	Specimen C	
Sample #	BH15 RC2 9.6M	Specimen D	
Client	Aurum Industrial Development Partnership	Test Variables	
		Specific Gravity	2.65
		Liquid Limit:	
		Plastic Limit:	

Remarks

Reviewed By: C. Lamoureux

Date: 21-Nov-16

Tested By: C. Woods

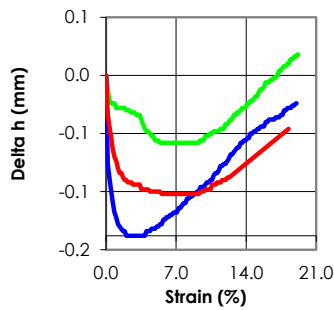
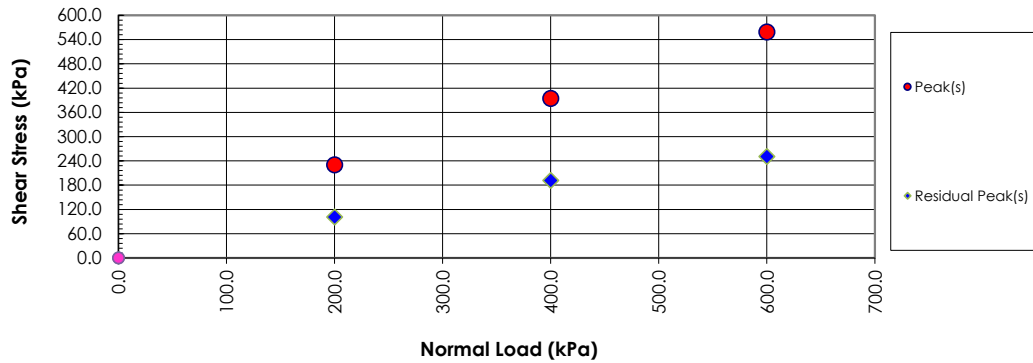

	Specimen			
	Initial	A	B	C
Moisture (%)	16.2	15.7	16.2	
Dry Density (g/cm ³)	1.824	1.848	1.887	
Void Ratio	0.453	0.434	0.404	
Saturation (%)	94.80	96.06	100.00	
Diameter (mm)	60.0	60.0	59.9	
Height (mm)	25.0	25.0	25.0	

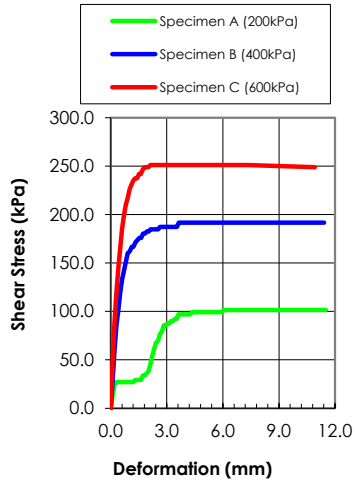

	Final	A	B	C	D
	Moisture (%)	14.7	14.3	13.4	
Dry Density (g/cm ³)	1.835	1.862	1.899		
Void Ratio	0.444	0.423	0.395		
Saturation (%)	94.74	99.15	99.36		
Diameter (mm)	60.0	60.0	59.9		
Height (mm)	24.440	24.294	24.310		
Normal Stress (kPa)	200.0	400.0	600.0		
Peak Stress (kPa)	230.0	394.6	558.8		
Residual Stress (kPa)	101.5	191.7	251.1		
Max. Shear Strain (%)	19.187	19.030	18.237		
Rate (mm/min)	0.008	0.008	0.008		

Project Date	
Date	21-Nov-16

Project:	Aurum Road Creek Crossing
Location:	-
Project Number:	123312651
Boring Number:	-
Sample Number:	BH06 RC7
Depth:	21.7m
Sample Type:	Undisturbed
Description:	Grey Sandstone
Test Type:	Direct Shear
Remarks:	

Reporting of these test results constitutes a testing service only. Engineering interpretation or evaluation of the test results is provided only on written request. The data presented above is for the sole use of the client stipulated above. Stantec is not responsible, nor can be held liable, for the use of this report by any other party, with or without the knowledge of Stantec.

Delta h

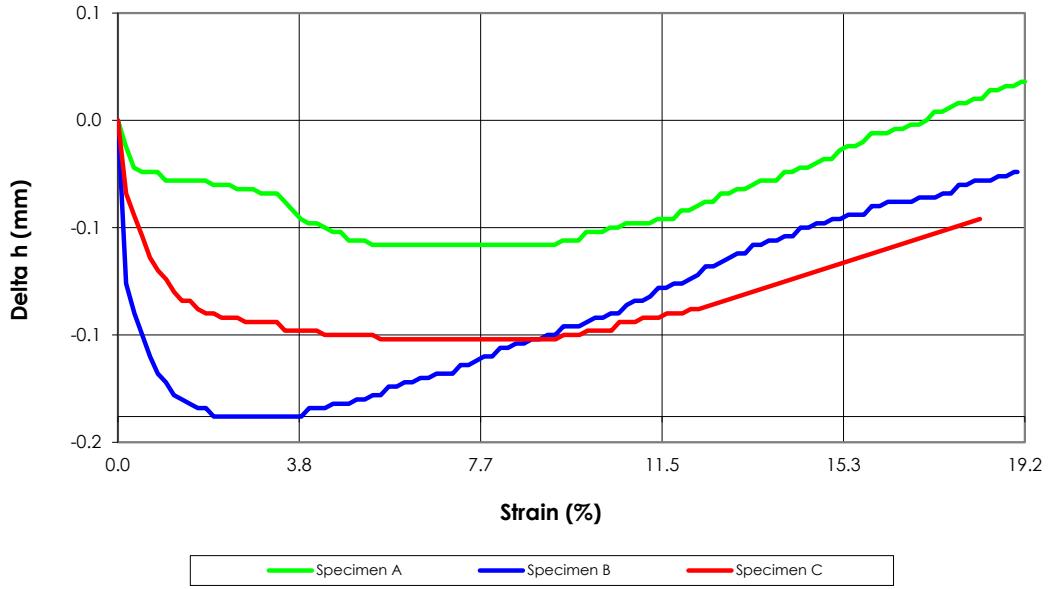

Stress-Deformation

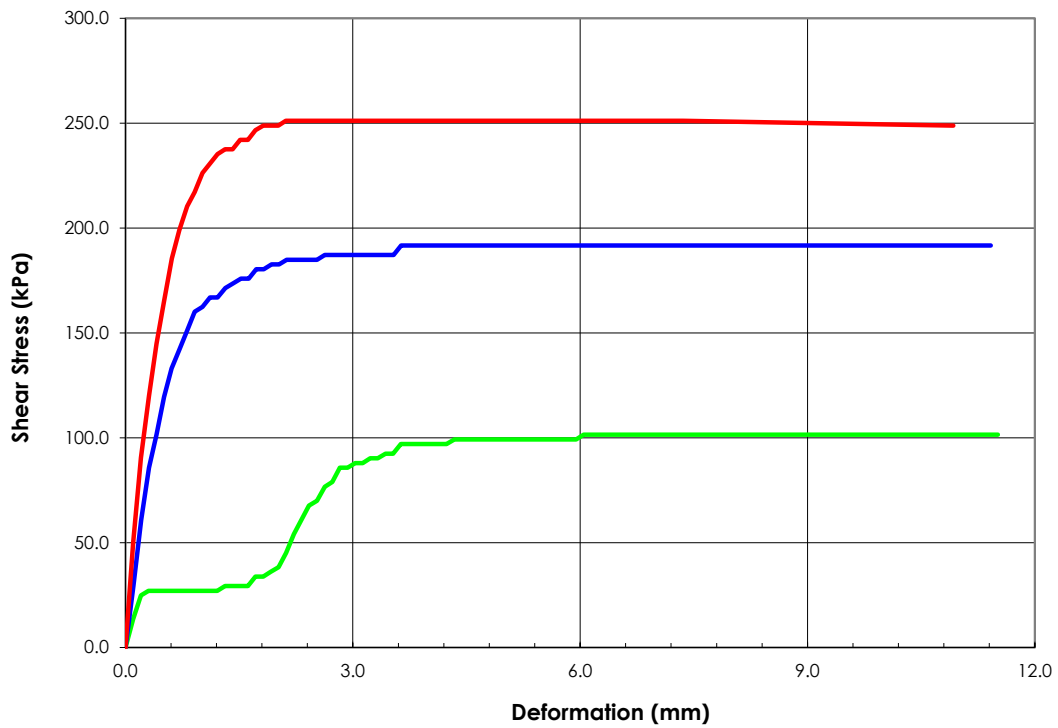

Specimen A Stress-Deformation

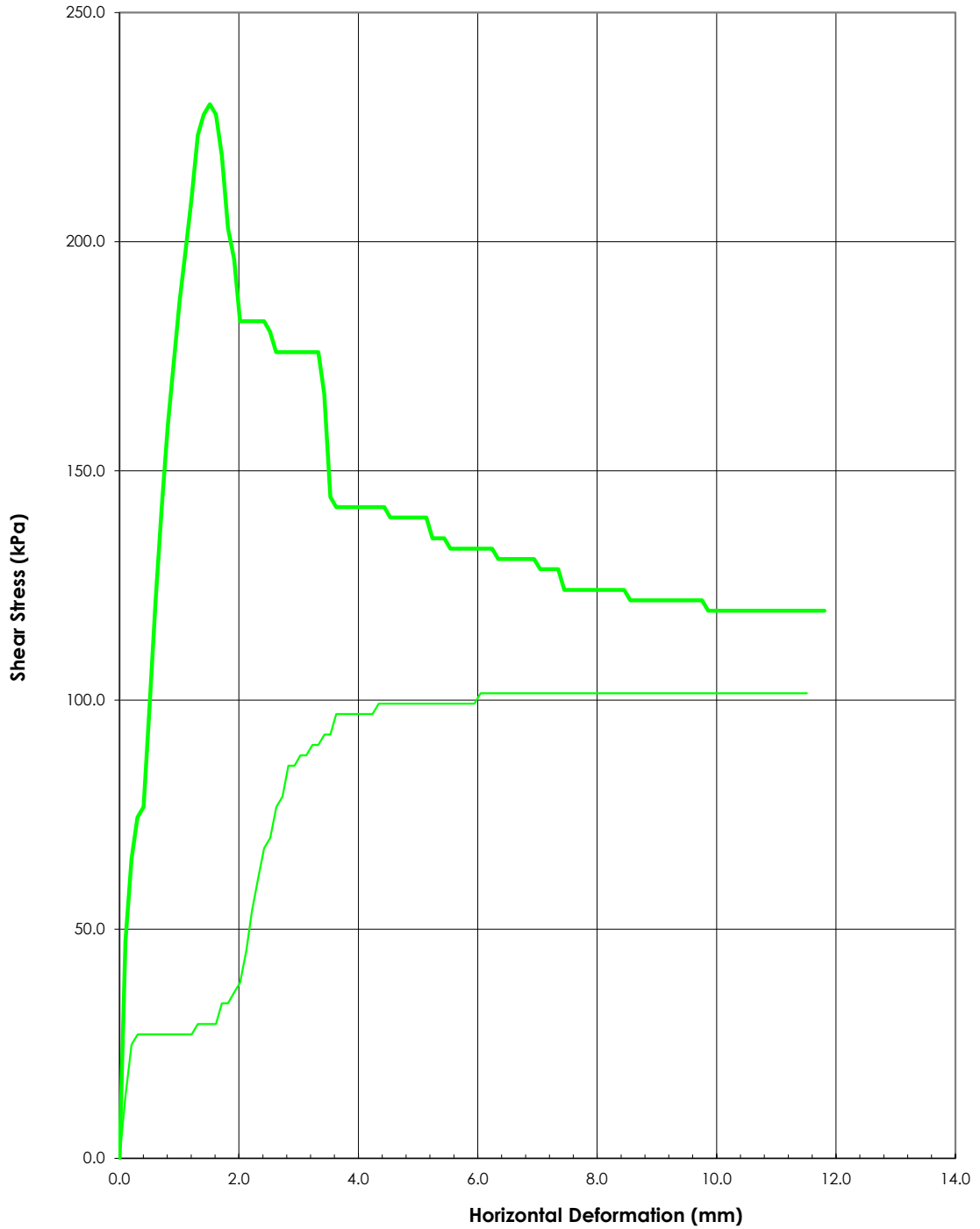

Specimen B Stress-Deformation

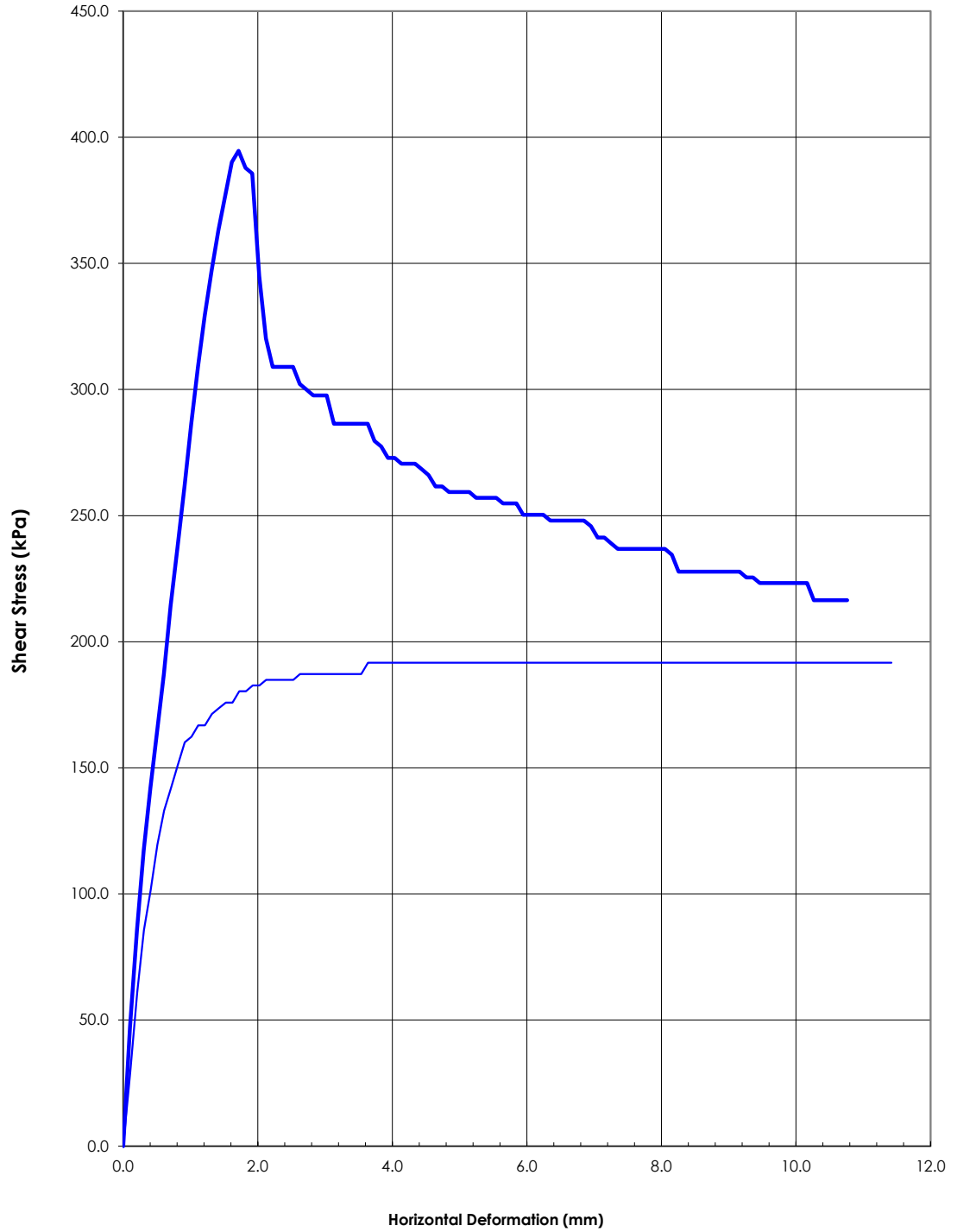

Specimen C Stress-Deformation

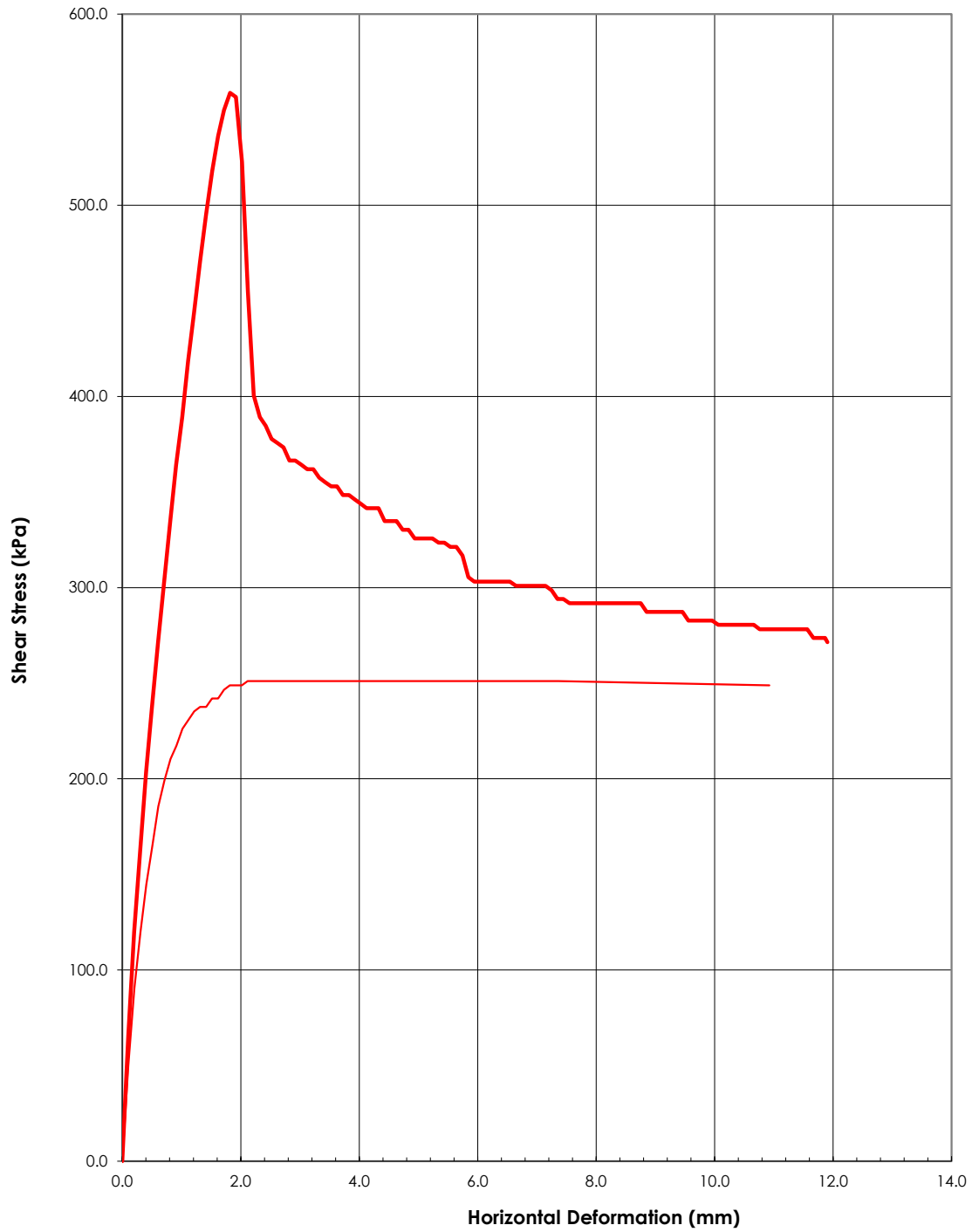

Specimen Information
Direct Shear Test

Stantec Consulting Ltd.

Project Information

Project: Aurum Road Creek Crossing
 Location:
 Project Number: 123312651
 Client: Aurum Industry Development Partnership
 Sample Location:
 Sample Number: BH06 RC7
 Boring Number:
 Tested By:
 Reduced By:
 Checked By:

Sample Description/Remarks	
Specimen A Description	Grey Sandstone
Remarks	
Specimen B Description	Grey Sandstone
Remarks	
Specimen C Description	Grey Sandstone
Remarks	
Specimen D Description	
Remarks	

Moisture Density Data

	Specimen A		Specimen B		Specimen C		Specimen D	
	Initial	Final	Initial	Final	Initial	Final	Initial	Final
Height (mm)	25.0	24.440	25.0	24.294	25.0	24.310		
Diameter (mm)	60.0	60.0	60.0	60.0	59.9	59.9		
Total Wet Weight of Ring & Soil (g)	2067.0	2066.0	2064.7	2064.0	2070.4	2067.6		
Weight of Ring (g)	1917.20	1917.20	1913.50	1913.50	1915.90	1915.90		
Wet Weight of Soil (g)	149.80	148.80	151.20	150.50	154.50	151.70		
Wt of Wet Soil & Dish (g)	-	155.26	-	156.05	-	160.02		
Wt of Dry Soil & Dish (g)	-	135.89	-	137.00	-	141.61		
Wt. Of Dish (g)	-	4.34	-	3.94	-	4.00		

Consolidation Calculations

	Specimen A	Specimen B	Specimen C	Specimen D
Initial Ref. Height (mm)	14.648	14.620	14.792	
Final Ref. Height (mm)	14.088	13.914	14.102	
Height after Consol (mm)	24.440	24.294	24.310	

Calculations

	Specimen A		Specimen B		Specimen C		Specimen D	
	Initial	Final	Initial	Final	Initial	Final	Initial	Final
Specific Gravity	2.65	2.65	2.65	2.65	2.65	2.65		
Area (cm2)	28.274	28.274	28.274	28.274	28.180	28.180		
Volume (cm3)	70.7	70.7	70.7	70.7	70.5	70.5		
Moisture Content (%)	16.2	14.7	15.7	14.3	16.2	13.4		
Wet Density (g/cm3)	2.119	2.105	2.139	2.129	2.193	2.153		
Dry Density (g/cm3)	1.824	1.835	1.848	1.862	1.887	1.899		
Saturation (%)	94.801	94.739	96.060	99.150	100.000	99.359		
Void Ratio	0.453	0.444	0.434	0.423	0.404	0.395		
Porosity (%)	31.185	29.172	30.245	27.675	28.789	26.298		



Specimen A Shear Data	Stantec Consulting Ltd.
Direct Shear Test	

File Location
lab_123312651_dsh_bh06rc7.HSD

Last Shear Pass

Reading Number	Time	Shear Force Kn	Horizontal Deformation (mm)	Vertical Deformation (mm)	Axial Strain (%)	Stress (kPa)
0	00:00:00	0.000	0.000	0.0000	0.000	0.000
1	00:23:47	0.038	0.100	-0.0120	0.167	13.530
2	00:37:45	0.070	0.202	-0.0220	0.337	24.804
3	00:50:44	0.077	0.304	-0.0240	0.507	27.059
4	01:03:56	0.077	0.404	-0.0240	0.673	27.059
5	01:16:47	0.077	0.504	-0.0240	0.840	27.059
6	01:29:56	0.077	0.606	-0.0280	1.010	27.059
7	01:42:59	0.077	0.706	-0.0280	1.177	27.059
8	01:55:59	0.077	0.808	-0.0280	1.347	27.059
9	02:08:55	0.077	0.908	-0.0280	1.513	27.059
10	02:21:42	0.077	1.010	-0.0280	1.683	27.059
11	02:34:23	0.077	1.110	-0.0280	1.850	27.059
12	02:46:50	0.077	1.210	-0.0300	2.017	27.059
13	02:59:35	0.083	1.312	-0.0300	2.187	29.314
14	03:12:26	0.083	1.414	-0.0300	2.357	29.314
15	03:25:07	0.083	1.514	-0.0320	2.523	29.314
16	03:37:36	0.083	1.614	-0.0320	2.690	29.314
17	03:50:24	0.096	1.716	-0.0320	2.860	33.824
18	04:03:02	0.096	1.816	-0.0340	3.027	33.824
19	04:15:30	0.102	1.916	-0.0340	3.193	36.079
20	04:28:04	0.108	2.018	-0.0340	3.363	38.334
21	04:41:07	0.128	2.120	-0.0380	3.533	45.099
22	04:54:05	0.153	2.220	-0.0420	3.700	54.118
23	05:06:34	0.172	2.320	-0.0460	3.867	60.883
24	05:19:29	0.191	2.422	-0.0480	4.037	67.648
25	05:32:12	0.198	2.526	-0.0480	4.210	69.903
26	05:44:58	0.217	2.628	-0.0500	4.380	76.668
27	05:57:39	0.223	2.728	-0.0520	4.547	78.922
28	06:09:59	0.242	2.828	-0.0520	4.713	85.687
29	06:22:48	0.242	2.930	-0.0560	4.883	85.687
30	06:35:22	0.249	3.030	-0.0560	5.050	87.942
31	06:47:37	0.249	3.130	-0.0560	5.217	87.942
32	06:59:52	0.255	3.230	-0.0580	5.383	90.197
33	07:12:34	0.255	3.330	-0.0580	5.550	90.197
34	07:25:19	0.261	3.432	-0.0580	5.720	92.452
35	07:37:41	0.261	3.532	-0.0580	5.887	92.452
36	07:50:28	0.274	3.632	-0.0580	6.053	96.962
37	08:03:12	0.274	3.734	-0.0580	6.223	96.962
38	08:15:45	0.274	3.834	-0.0580	6.390	96.962
39	08:28:34	0.274	3.936	-0.0580	6.560	96.962
40	08:41:10	0.274	4.036	-0.0580	6.727	96.962
41	08:53:37	0.274	4.136	-0.0580	6.893	96.962
42	09:06:19	0.274	4.238	-0.0580	7.063	96.962
43	09:19:00	0.281	4.340	-0.0580	7.233	99.217
44	09:31:54	0.281	4.440	-0.0580	7.400	99.217
45	09:44:20	0.281	4.540	-0.0580	7.567	99.217

46	09:57:12	0.281	4.642	-0.0580	7.737	99.217
47	10:09:59	0.281	4.742	-0.0580	7.903	99.217
48	10:22:44	0.281	4.842	-0.0580	8.070	99.217
49	10:35:30	0.281	4.942	-0.0580	8.237	99.217
50	10:48:15	0.281	5.042	-0.0580	8.403	99.217
51	11:00:45	0.281	5.142	-0.0580	8.570	99.217
52	11:13:31	0.281	5.244	-0.0580	8.740	99.217
53	11:26:20	0.281	5.344	-0.0580	8.907	99.217
54	11:38:39	0.281	5.444	-0.0580	9.073	99.217
55	11:51:22	0.281	5.544	-0.0580	9.240	99.217
56	12:04:14	0.281	5.644	-0.0560	9.407	99.217
57	12:16:50	0.281	5.744	-0.0560	9.573	99.217
58	12:29:41	0.281	5.846	-0.0560	9.743	99.217
59	12:42:24	0.281	5.946	-0.0520	9.910	99.217
60	12:54:48	0.287	6.046	-0.0520	10.077	101.472
61	13:07:11	0.287	6.146	-0.0520	10.243	101.472
62	13:19:57	0.287	6.246	-0.0500	10.410	101.472
63	13:32:24	0.287	6.346	-0.0500	10.577	101.472
64	13:45:15	0.287	6.448	-0.0480	10.747	101.472
65	13:58:01	0.287	6.548	-0.0480	10.913	101.472
66	14:10:33	0.287	6.648	-0.0480	11.080	101.472
67	14:22:47	0.287	6.748	-0.0480	11.247	101.472
68	14:35:33	0.287	6.848	-0.0460	11.413	101.472
69	14:47:44	0.287	6.948	-0.0460	11.580	101.472
70	15:00:18	0.287	7.050	-0.0460	11.750	101.472
71	15:12:55	0.287	7.150	-0.0420	11.917	101.472
72	15:25:20	0.287	7.250	-0.0420	12.083	101.472
73	15:37:59	0.287	7.352	-0.0400	12.253	101.472
74	15:50:40	0.287	7.454	-0.0380	12.423	101.472
75	16:03:24	0.287	7.554	-0.0380	12.590	101.472
76	16:15:50	0.287	7.654	-0.0340	12.757	101.472
77	16:28:15	0.287	7.756	-0.0340	12.927	101.472
78	16:40:43	0.287	7.856	-0.0320	13.093	101.472
79	16:52:53	0.287	7.956	-0.0320	13.260	101.472
80	17:05:12	0.287	8.056	-0.0300	13.427	101.472
81	17:17:44	0.287	8.156	-0.0280	13.593	101.472
82	17:30:14	0.287	8.256	-0.0280	13.760	101.472
83	17:42:59	0.287	8.358	-0.0280	13.930	101.472
84	17:55:37	0.287	8.458	-0.0240	14.097	101.472
85	18:07:58	0.287	8.558	-0.0240	14.263	101.472
86	18:20:05	0.287	8.658	-0.0220	14.430	101.472
87	18:32:45	0.287	8.758	-0.0220	14.597	101.472
88	18:45:06	0.287	8.858	-0.0200	14.763	101.472
89	18:57:46	0.287	8.960	-0.0180	14.933	101.472
90	19:10:40	0.287	9.060	-0.0180	15.100	101.472
91	19:23:08	0.287	9.160	-0.0140	15.267	101.472
92	19:35:31	0.287	9.260	-0.0120	15.433	101.472
93	19:48:17	0.287	9.360	-0.0120	15.600	101.472
94	20:00:35	0.287	9.460	-0.0100	15.767	101.472
95	20:13:24	0.287	9.562	-0.0060	15.937	101.472
96	20:26:09	0.287	9.662	-0.0060	16.103	101.472
97	20:38:41	0.287	9.762	-0.0060	16.270	101.472
98	20:51:19	0.287	9.862	-0.0040	16.437	101.472
99	21:04:15	0.287	9.962	-0.0040	16.603	101.472
100	21:16:57	0.287	10.062	-0.0020	16.770	101.472
101	21:29:58	0.287	10.164	-0.0020	16.940	101.472
102	21:42:42	0.287	10.264	0.0000	17.107	101.472

103	21:55:03	0.287	10.364	0.0040	17.273	101.472
104	22:07:24	0.287	10.464	0.0040	17.440	101.472
105	22:20:07	0.287	10.564	0.0060	17.607	101.472
106	22:32:49	0.287	10.664	0.0080	17.773	101.472
107	22:45:43	0.287	10.766	0.0080	17.943	101.472
108	22:58:46	0.287	10.866	0.0100	18.110	101.472
109	23:11:17	0.287	10.966	0.0100	18.277	101.472
110	23:23:43	0.287	11.066	0.0140	18.443	101.472
111	23:36:24	0.287	11.166	0.0140	18.610	101.472
112	23:48:42	0.287	11.266	0.0160	18.777	101.472
113	24:01:26	0.287	11.368	0.0160	18.947	101.472
114	24:14:10	0.287	11.468	0.0180	19.113	101.472
115	24:19:37	0.287	11.512	0.0180	19.187	101.472

Specimen B Shear Data**Direct Shear Test**

Stantec Consulting Ltd.

File Location

lab_123312651_dsh_bh06rc7.HSD

Last Shear Pass

Reading Number	Time	Shear Force Kn	Horizontal Deformation (mm)	Vertical Deformation (mm)	Axial Strain (%)	Stress (kPa)
0	00:00:00	0.000	0.000	0.0000	0.000	0.000
1	00:18:02	0.083	0.104	-0.0760	0.173	29.314
2	00:32:48	0.172	0.208	-0.0900	0.347	60.883
3	00:46:41	0.242	0.308	-0.1000	0.513	85.687
4	00:59:44	0.287	0.408	-0.1100	0.680	101.472
5	01:12:55	0.338	0.508	-0.1180	0.847	119.511
6	01:26:19	0.376	0.608	-0.1220	1.013	133.041
7	01:39:27	0.402	0.710	-0.1280	1.183	142.060
8	01:52:42	0.427	0.812	-0.1300	1.353	151.080
9	02:05:53	0.453	0.914	-0.1320	1.523	160.100
10	02:18:58	0.459	1.016	-0.1340	1.693	162.355
11	02:31:47	0.472	1.116	-0.1340	1.860	166.865
12	02:44:36	0.472	1.216	-0.1380	2.027	166.865
13	02:57:31	0.485	1.318	-0.1380	2.197	171.374
14	03:10:32	0.491	1.422	-0.1380	2.370	173.629
15	03:23:41	0.497	1.524	-0.1380	2.540	175.884
16	03:36:43	0.497	1.624	-0.1380	2.707	175.884
17	03:49:34	0.510	1.724	-0.1380	2.873	180.394
18	04:02:31	0.510	1.826	-0.1380	3.043	180.394
19	04:15:18	0.516	1.926	-0.1380	3.210	182.649
20	04:27:42	0.516	2.026	-0.1380	3.377	182.649
21	04:39:57	0.523	2.126	-0.1380	3.543	184.904
22	04:52:40	0.523	2.226	-0.1380	3.710	184.904
23	05:05:28	0.523	2.328	-0.1380	3.880	184.904
24	05:18:05	0.523	2.428	-0.1340	4.047	184.904
25	05:31:00	0.523	2.528	-0.1340	4.213	184.904
26	05:43:20	0.529	2.628	-0.1340	4.380	187.159
27	05:56:05	0.529	2.730	-0.1320	4.550	187.159
28	06:08:31	0.529	2.832	-0.1320	4.720	187.159
29	06:21:02	0.529	2.932	-0.1320	4.887	187.159
30	06:33:04	0.529	3.032	-0.1300	5.053	187.159
31	06:45:40	0.529	3.134	-0.1300	5.223	187.159
32	06:58:20	0.529	3.236	-0.1280	5.393	187.159
33	07:10:57	0.529	3.336	-0.1280	5.560	187.159
34	07:23:12	0.529	3.436	-0.1240	5.727	187.159
35	07:35:49	0.529	3.538	-0.1240	5.897	187.159
36	07:48:25	0.542	3.638	-0.1220	6.063	191.669
37	08:00:52	0.542	3.738	-0.1220	6.230	191.669
38	08:13:29	0.542	3.840	-0.1200	6.400	191.669
39	08:26:01	0.542	3.942	-0.1200	6.570	191.669
40	08:38:50	0.542	4.046	-0.1180	6.743	191.669
41	08:51:27	0.542	4.146	-0.1180	6.910	191.669
42	09:04:00	0.542	4.248	-0.1180	7.080	191.669
43	09:16:18	0.542	4.348	-0.1140	7.247	191.669
44	09:28:56	0.542	4.450	-0.1140	7.417	191.669
45	09:41:33	0.542	4.550	-0.1120	7.583	191.669

46	09:53:53	0.542	4.650	-0.1100	7.750	191.669
47	10:06:35	0.542	4.752	-0.1100	7.920	191.669
48	10:19:14	0.542	4.852	-0.1060	8.087	191.669
49	10:31:40	0.542	4.952	-0.1060	8.253	191.669
50	10:44:03	0.542	5.052	-0.1040	8.420	191.669
51	10:56:48	0.542	5.152	-0.1040	8.587	191.669
52	11:09:24	0.542	5.252	-0.1020	8.753	191.669
53	11:22:11	0.542	5.354	-0.1020	8.923	191.669
54	11:34:55	0.542	5.454	-0.1000	9.090	191.669
55	11:47:21	0.542	5.554	-0.1000	9.257	191.669
56	11:59:39	0.542	5.654	-0.0960	9.423	191.669
57	12:12:28	0.542	5.754	-0.0960	9.590	191.669
58	12:24:53	0.542	5.854	-0.0960	9.757	191.669
59	12:37:58	0.542	5.956	-0.0940	9.927	191.669
60	12:50:59	0.542	6.056	-0.0920	10.093	191.669
61	13:03:33	0.542	6.156	-0.0920	10.260	191.669
62	13:16:10	0.542	6.256	-0.0900	10.427	191.669
63	13:28:56	0.542	6.356	-0.0900	10.593	191.669
64	13:41:30	0.542	6.456	-0.0860	10.760	191.669
65	13:54:17	0.542	6.558	-0.0840	10.930	191.669
66	14:07:15	0.542	6.658	-0.0840	11.097	191.669
67	14:20:06	0.542	6.758	-0.0820	11.263	191.669
68	14:32:45	0.542	6.858	-0.0780	11.430	191.669
69	14:45:37	0.542	6.958	-0.0780	11.597	191.669
70	14:57:58	0.542	7.058	-0.0760	11.763	191.669
71	15:10:34	0.542	7.160	-0.0760	11.933	191.669
72	15:23:09	0.542	7.260	-0.0740	12.100	191.669
73	15:35:20	0.542	7.360	-0.0720	12.267	191.669
74	15:47:44	0.542	7.460	-0.0680	12.433	191.669
75	16:00:36	0.542	7.560	-0.0680	12.600	191.669
76	16:13:06	0.542	7.660	-0.0660	12.767	191.669
77	16:25:53	0.542	7.762	-0.0640	12.937	191.669
78	16:38:28	0.542	7.862	-0.0620	13.103	191.669
79	16:50:41	0.542	7.962	-0.0620	13.270	191.669
80	17:02:56	0.542	8.062	-0.0580	13.437	191.669
81	17:15:29	0.542	8.162	-0.0580	13.603	191.669
82	17:27:54	0.542	8.262	-0.0560	13.770	191.669
83	17:40:29	0.542	8.364	-0.0560	13.940	191.669
84	17:53:13	0.542	8.464	-0.0540	14.107	191.669
85	18:05:44	0.542	8.564	-0.0540	14.273	191.669
86	18:18:17	0.542	8.666	-0.0500	14.443	191.669
87	18:30:55	0.542	8.768	-0.0500	14.613	191.669
88	18:43:26	0.542	8.868	-0.0480	14.780	191.669
89	18:55:50	0.542	8.968	-0.0480	14.947	191.669
90	19:08:27	0.542	9.070	-0.0460	15.117	191.669
91	19:21:04	0.542	9.170	-0.0460	15.283	191.669
92	19:33:15	0.542	9.270	-0.0440	15.450	191.669
93	19:45:21	0.542	9.370	-0.0440	15.617	191.669
94	19:57:58	0.542	9.470	-0.0440	15.783	191.669
95	20:10:17	0.542	9.570	-0.0400	15.950	191.669
96	20:22:57	0.542	9.672	-0.0400	16.120	191.669
97	20:35:39	0.542	9.772	-0.0380	16.287	191.669
98	20:48:00	0.542	9.872	-0.0380	16.453	191.669
99	21:00:24	0.542	9.972	-0.0380	16.620	191.669
100	21:13:11	0.542	10.072	-0.0380	16.787	191.669
101	21:25:38	0.542	10.172	-0.0360	16.953	191.669
102	21:38:26	0.542	10.274	-0.0360	17.123	191.669

103	21:51:06	0.542	10.374	-0.0360	17.290	191.669
104	22:03:41	0.542	10.474	-0.0340	17.457	191.669
105	22:16:00	0.542	10.574	-0.0340	17.623	191.669
106	22:28:46	0.542	10.674	-0.0300	17.790	191.669
107	22:41:05	0.542	10.774	-0.0300	17.957	191.669
108	22:53:50	0.542	10.876	-0.0280	18.127	191.669
109	23:06:48	0.542	10.976	-0.0280	18.293	191.669
110	23:19:15	0.542	11.076	-0.0280	18.460	191.669
111	23:31:59	0.542	11.176	-0.0260	18.627	191.669
112	23:44:43	0.542	11.276	-0.0260	18.793	191.669
113	23:57:19	0.542	11.376	-0.0240	18.960	191.669
114	24:02:57	0.542	11.418	-0.0240	19.030	191.669

Specimen C Shear Data	Stantec Consulting Ltd.
Direct Shear Test	

File Location
lab_123312651_dsh_bh06rc7.HSD

Last Shear Pass

Reading Number	Time	Shear Force Kn	Horizontal Deformation (mm)	Vertical Deformation (mm)	Axial Strain (%)	Stress (kPa)
0	00:00:00	0.000	0.000	0.0000	0.000	0.000
1	00:20:03	0.140	0.102	-0.0340	0.170	49.774
2	00:34:23	0.255	0.204	-0.0440	0.341	90.498
3	00:48:30	0.338	0.308	-0.0540	0.514	119.910
4	01:01:59	0.408	0.408	-0.0640	0.681	144.798
5	01:14:52	0.465	0.508	-0.0700	0.848	165.160
6	01:28:10	0.523	0.610	-0.0740	1.018	185.522
7	01:41:07	0.561	0.712	-0.0800	1.189	199.097
8	01:54:16	0.593	0.812	-0.0840	1.356	210.409
9	02:06:55	0.612	0.914	-0.0840	1.526	217.196
10	02:19:10	0.638	1.014	-0.0880	1.693	226.246
11	02:31:56	0.650	1.114	-0.0900	1.860	230.771
12	02:44:13	0.663	1.214	-0.0900	2.027	235.296
13	02:56:41	0.669	1.314	-0.0920	2.194	237.559
14	03:09:16	0.669	1.414	-0.0920	2.361	237.559
15	03:21:40	0.682	1.514	-0.0920	2.528	242.083
16	03:34:18	0.682	1.616	-0.0940	2.698	242.083
17	03:46:51	0.695	1.716	-0.0940	2.865	246.608
18	03:59:12	0.701	1.816	-0.0940	3.032	248.871
19	04:11:41	0.701	1.916	-0.0940	3.199	248.871
20	04:24:22	0.701	2.016	-0.0940	3.366	248.871
21	04:36:53	0.708	2.116	-0.0980	3.533	251.133
22	04:49:35	0.708	2.218	-0.0980	3.703	251.133
23	05:02:26	0.708	2.318	-0.0980	3.870	251.133
24	05:15:00	0.708	2.420	-0.0980	4.040	251.133
25	05:27:18	0.708	2.520	-0.0980	4.207	251.133
26	05:40:06	0.708	2.622	-0.1000	4.377	251.133
27	05:52:44	0.708	2.722	-0.1000	4.544	251.133
28	06:05:42	0.708	2.824	-0.1000	4.715	251.133
29	06:18:37	0.708	2.926	-0.1000	4.885	251.133
30	06:31:11	0.708	3.026	-0.1000	5.052	251.133
31	06:44:01	0.708	3.126	-0.1000	5.219	251.133
32	06:57:00	0.708	3.228	-0.1000	5.389	251.133
33	07:09:42	0.708	3.328	-0.1020	5.556	251.133
34	07:22:20	0.708	3.428	-0.1020	5.723	251.133
35	07:35:16	0.708	3.530	-0.1020	5.893	251.133
36	07:47:58	0.708	3.630	-0.1020	6.060	251.133
37	08:01:02	0.708	3.732	-0.1020	6.230	251.133
38	08:14:02	0.708	3.832	-0.1020	6.397	251.133
39	08:26:36	0.708	3.932	-0.1020	6.564	251.133
40	08:39:29	0.708	4.034	-0.1020	6.735	251.133
41	08:52:09	0.708	4.136	-0.1020	6.905	251.133
42	09:04:46	0.708	4.236	-0.1020	7.072	251.133
43	09:17:07	0.708	4.336	-0.1020	7.239	251.133
44	09:29:51	0.708	4.438	-0.1020	7.409	251.133
45	09:42:39	0.708	4.538	-0.1020	7.576	251.133

46	09:55:06	0.708	4.638	-0.1020	7.743	251.133
47	10:07:53	0.708	4.740	-0.1020	7.913	251.133
48	10:20:37	0.708	4.842	-0.1020	8.083	251.133
49	10:33:06	0.708	4.942	-0.1020	8.250	251.133
50	10:45:38	0.708	5.044	-0.1020	8.421	251.133
51	10:57:56	0.708	5.144	-0.1020	8.588	251.133
52	11:10:34	0.708	5.244	-0.1020	8.755	251.133
53	11:23:07	0.708	5.346	-0.1020	8.925	251.133
54	11:35:14	0.708	5.446	-0.1020	9.092	251.133
55	11:47:51	0.708	5.548	-0.1020	9.262	251.133
56	12:00:27	0.708	5.648	-0.1000	9.429	251.133
57	12:12:40	0.708	5.748	-0.1000	9.596	251.133
58	12:25:18	0.708	5.850	-0.1000	9.766	251.133
59	12:37:55	0.708	5.952	-0.0980	9.937	251.133
60	12:50:28	0.708	6.052	-0.0980	10.104	251.133
61	13:02:45	0.708	6.152	-0.0980	10.270	251.133
62	13:15:22	0.708	6.254	-0.0980	10.441	251.133
63	13:27:59	0.708	6.354	-0.0940	10.608	251.133
64	13:40:18	0.708	6.454	-0.0940	10.775	251.133
65	13:52:34	0.708	6.554	-0.0940	10.942	251.133
66	14:05:08	0.708	6.654	-0.0920	11.109	251.133
67	14:17:32	0.708	6.754	-0.0920	11.275	251.133
68	14:29:56	0.708	6.856	-0.0920	11.446	251.133
69	14:42:35	0.708	6.956	-0.0900	11.613	251.133
70	14:55:03	0.708	7.056	-0.0900	11.780	251.133
71	15:07:31	0.708	7.156	-0.0900	11.947	251.133
72	15:20:21	0.708	7.256	-0.0880	12.114	251.133
73	15:33:02	0.708	7.358	-0.0880	12.284	251.133
74	15:44:01	0.701	10.924	-0.0460	18.237	248.871

Specimen C Consolidation
Direct Shear Test

Stantec Consulting Ltd.

File Location

lab_123312651_dsh_bh06rc7.HSD

Last Consolidation Sequence

Reading Number	Time	Disp. (mm)	Settlement (mm)	Void Ratio
0.0	00:00:00	0.5824	0.0000	0.4043
1.0	00:00:01	0.5827	-0.0003	0.4034
2.0	00:00:02	0.5813	0.0010	0.4015
3.0	00:00:03	0.5817	0.0006	0.4020
4.0	00:00:04	0.5671	0.0153	0.3812
5.0	00:00:05	0.5609	0.0215	0.3723
6.0	00:00:06	0.5600	0.0224	0.3711
7.0	00:00:12	0.5589	0.0235	0.3695
8.0	00:00:15	0.5587	0.0237	0.3692
9.0	00:00:30	0.5580	0.0244	0.3681
10.0	00:01:01	0.5573	0.0250	0.3672
11.0	00:02:01	0.5569	0.0255	0.3666
12.0	00:04:01	0.5565	0.0259	0.3660
13.0	00:08:01	0.5561	0.0262	0.3656
14.0	00:15:01	0.5560	0.0264	0.3653
15.0	00:30:02	0.5557	0.0267	0.3649
16.0	01:00:04	0.5557	0.0267	0.3649
17.0	02:00:09	0.5556	0.0268	0.3648
18.0	04:00:17	0.5554	0.0270	0.3644
19.0	08:00:33	0.5553	0.0271	0.3643
20.0	12:03:35	0.5552	0.0272	0.3642
21.0	19:06:35	0.5552	0.0272	0.3642

Specimen A Consolidation Graphs

Consolidation Graph (Square Root Time)

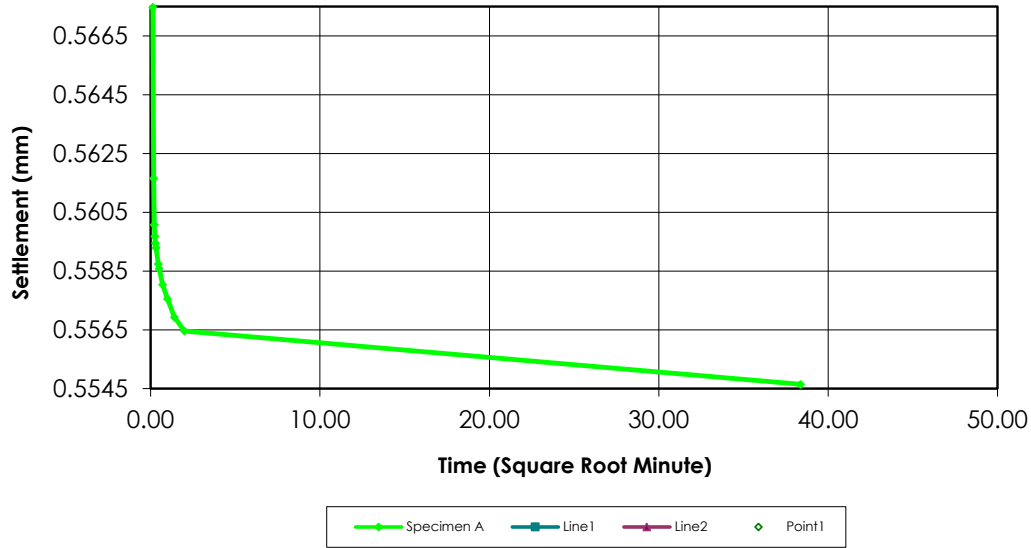

Consolidation Graph (Logarithmic Time)

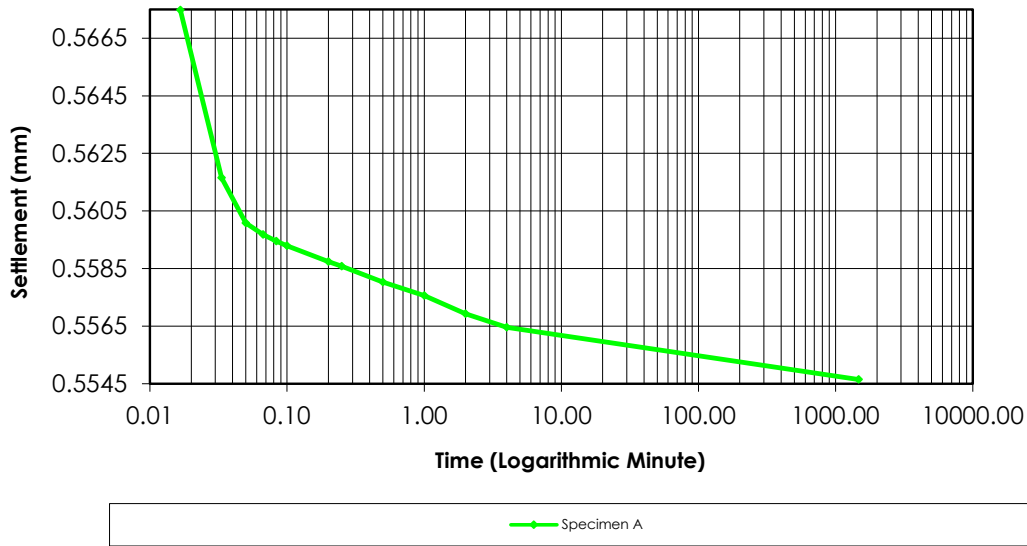

Specimen B Consolidation Graphs

Consolidation Graph (Square Root Time)

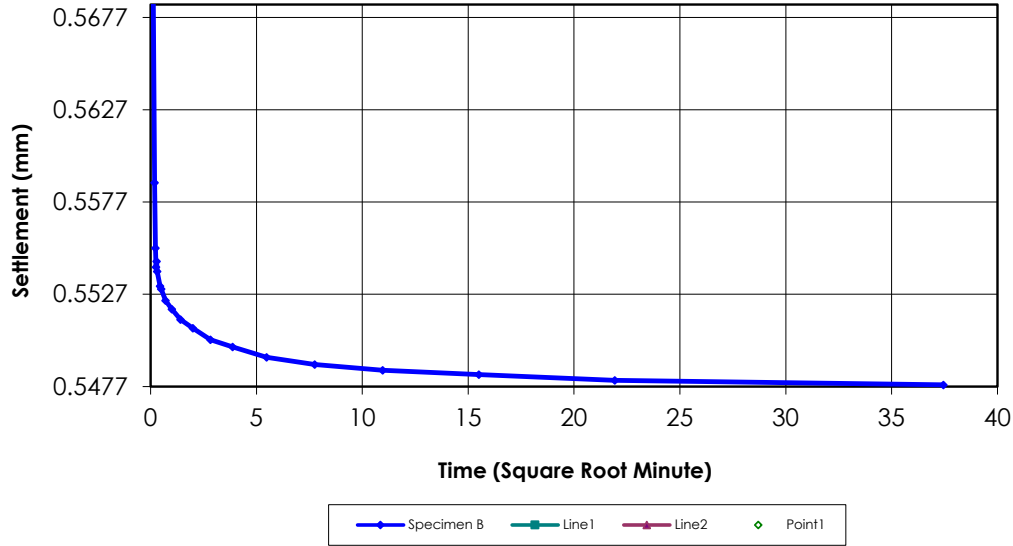

Consolidation Graph (Logarithmic Time)

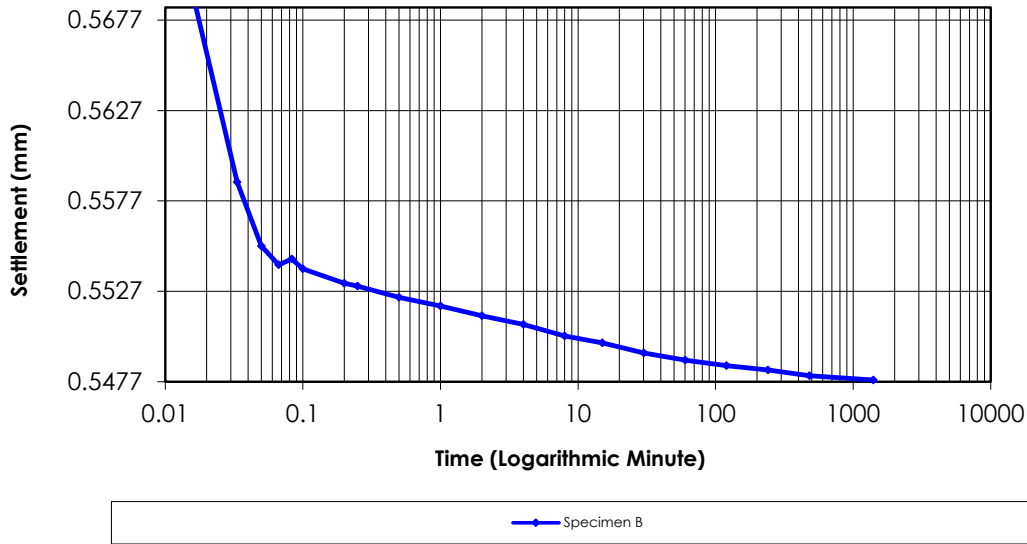

Specimen C Consolidation Graphs

Consolidation Graph (Square Root Time)

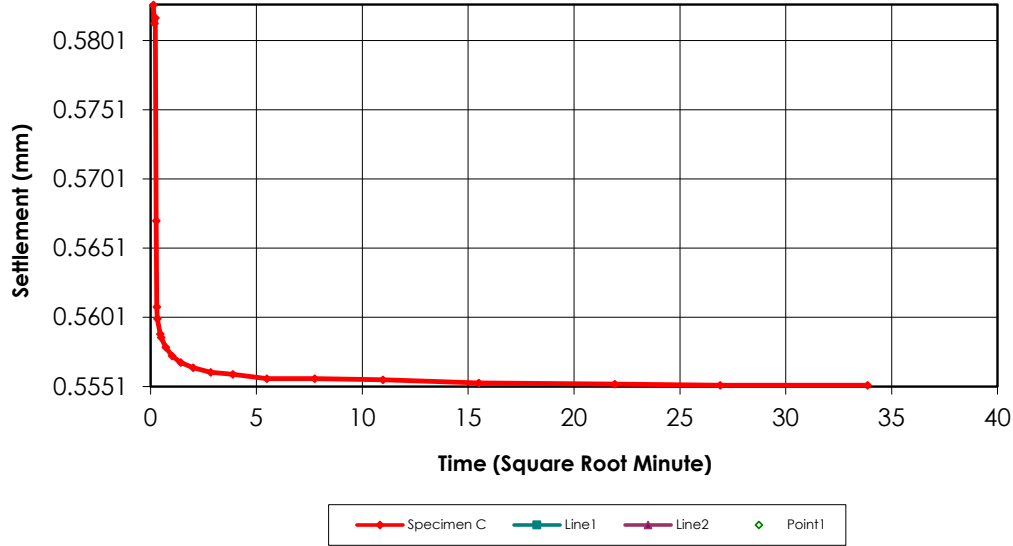

Consolidation Graph (Logarithmic Time)

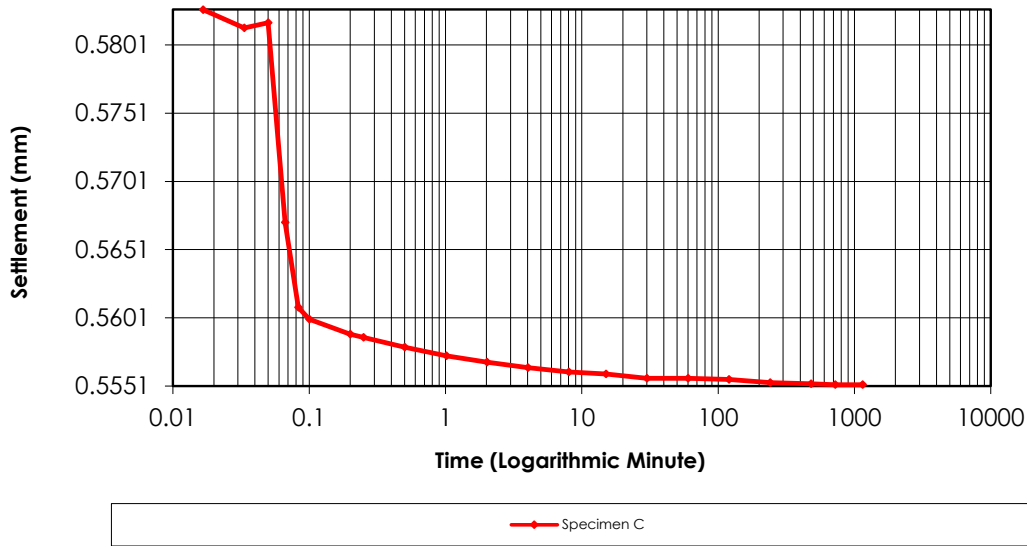

Consolidation Graph (Square Root Time)

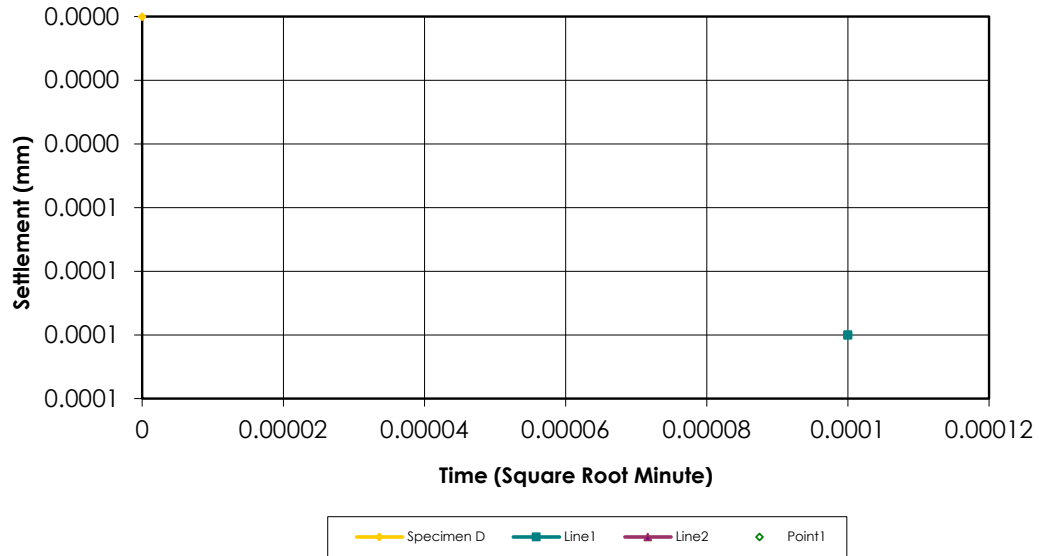

Consolidation Graph (Logarithmic Time)



Specimen C All Shear Pass Data

Stantec Consulting Ltd.

Direct Shear Test

File Location

lab_123312651_dsh_bh06rc7.HSD

PASS 1

Reading Number	Time	Shear Force Kn	Horizontal Deformation (mm)	Vertical Deformation (mm)	Shear Force Kn	Horizontal Deformation (mm)	Vertical Deformation (mm)	Axial Strain (%)	Stress (kPa)
0	00:00:00	0.0	2.424	14.0980	0.0	0.000	0.0000	0.000	0.000
1	00:22:18	0.2	2.524	14.0980	0.2	0.100	0.0000	0.167	65.611
2	00:37:21	0.3	2.626	14.0940	0.3	0.202	-0.0040	0.337	119.910
3	00:51:40	0.5	2.726	14.0860	0.5	0.302	-0.0120	0.504	162.897
4	01:05:23	0.6	2.826	14.0780	0.6	0.402	-0.0200	0.671	203.622
5	01:18:38	0.7	2.926	14.0740	0.7	0.502	-0.0240	0.838	237.559
6	01:33:01	0.8	3.030	14.0700	0.8	0.606	-0.0280	1.012	271.495
7	01:46:54	0.9	3.130	14.0680	0.9	0.706	-0.0300	1.179	303.170
8	02:00:38	0.9	3.232	14.0680	0.9	0.808	-0.0300	1.349	334.844
9	02:14:06	1.0	3.334	14.0680	1.0	0.910	-0.0300	1.519	364.256
10	02:27:03	1.1	3.434	14.0680	1.1	1.010	-0.0300	1.686	389.143
11	02:40:38	1.2	3.534	14.0700	1.2	1.110	-0.0280	1.853	418.555
12	02:53:41	1.2	3.634	14.0740	1.2	1.210	-0.0240	2.020	443.443
13	03:07:06	1.3	3.736	14.0840	1.3	1.312	-0.0140	2.190	470.592
14	03:20:58	1.4	3.840	14.0940	1.4	1.416	-0.0040	2.364	495.479
15	03:34:15	1.5	3.942	14.1060	1.5	1.518	0.0080	2.534	518.104
16	03:47:25	1.5	4.042	14.1160	1.5	1.618	0.0180	2.701	536.203
17	04:00:03	1.5	4.142	14.1320	1.5	1.718	0.0340	2.868	549.778
18	04:12:58	1.6	4.244	14.1460	1.6	1.820	0.0480	3.038	558.828
19	04:25:06	1.6	4.344	14.1620	1.6	1.920	0.0640	3.205	556.566
20	04:36:15	1.5	4.444	14.1720	1.5	2.020	0.0740	3.372	522.629
21	04:47:26	1.3	4.544	14.1740	1.3	2.120	0.0760	3.539	454.755
22	04:59:04	1.1	4.644	14.1740	1.1	2.220	0.0760	3.706	400.456
23	05:11:25	1.1	4.746	14.1740	1.1	2.322	0.0760	3.876	389.143
24	05:23:45	1.1	4.846	14.1740	1.1	2.422	0.0760	4.043	384.619
25	05:36:22	1.1	4.946	14.1740	1.1	2.522	0.0760	4.210	377.831
26	05:48:36	1.1	5.046	14.1740	1.1	2.622	0.0760	4.377	375.569
27	06:00:54	1.1	5.146	14.1740	1.1	2.722	0.0760	4.544	373.306
28	06:13:17	1.0	5.246	14.1740	1.0	2.822	0.0760	4.711	366.519
29	06:25:29	1.0	5.346	14.1740	1.0	2.922	0.0760	4.878	366.519
30	06:37:54	1.0	5.448	14.1780	1.0	3.024	0.0800	5.048	364.256
31	06:50:32	1.0	5.548	14.1800	1.0	3.124	0.0820	5.215	361.994
32	07:02:44	1.0	5.648	14.1820	1.0	3.224	0.0840	5.382	361.994
33	07:14:54	1.0	5.748	14.1820	1.0	3.324	0.0840	5.549	357.469
34	07:27:28	1.0	5.848	14.1840	1.0	3.424	0.0860	5.716	355.207
35	07:39:51	1.0	5.950	14.1880	1.0	3.526	0.0900	5.886	352.944
36	07:52:09	1.0	6.050	14.1900	1.0	3.626	0.0920	6.053	352.944
37	08:04:44	1.0	6.150	14.1920	1.0	3.726	0.0940	6.220	348.419
38	08:17:01	1.0	6.250	14.1960	1.0	3.826	0.0980	6.387	348.419
39	08:29:22	1.0	6.350	14.1960	1.0	3.926	0.0980	6.554	346.157
40	08:41:49	1.0	6.450	14.1980	1.0	4.026	0.1000	6.721	343.894
41	08:54:10	1.0	6.550	14.2000	1.0	4.126	0.1020	6.888	341.632
42	09:06:35	1.0	6.652	14.2060	1.0	4.228	0.1080	7.058	341.632
43	09:19:06	1.0	6.752	14.2080	1.0	4.328	0.1100	7.225	341.632
44	09:31:26	0.9	6.852	14.2100	0.9	4.428	0.1120	7.392	334.844
45	09:43:48	0.9	6.954	14.2120	0.9	4.530	0.1140	7.563	334.844
46	09:56:26	0.9	7.056	14.2160	0.9	4.632	0.1180	7.733	334.844

47	10:09:03	0.9	7.156	14.2180	0.9	4.732	0.1200	7.900	330.319
48	10:21:33	0.9	7.256	14.2200	0.9	4.832	0.1220	8.067	330.319
49	10:34:13	0.9	7.358	14.2120	0.9	4.934	0.1140	8.237	325.795
50	10:46:55	0.9	7.458	14.2120	0.9	5.034	0.1140	8.404	325.795
51	10:59:37	0.9	7.560	14.2160	0.9	5.136	0.1180	8.574	325.795
52	11:11:42	0.9	7.660	14.2180	0.9	5.236	0.1200	8.741	325.795
53	11:24:25	0.9	7.762	14.2200	0.9	5.338	0.1220	8.912	323.532
54	11:37:06	0.9	7.862	14.2260	0.9	5.438	0.1280	9.078	323.532
55	11:49:23	0.9	7.962	14.2280	0.9	5.538	0.1300	9.245	321.270
56	12:02:12	0.9	8.064	14.2300	0.9	5.640	0.1320	9.416	321.270
57	12:15:03	0.9	8.166	14.2340	0.9	5.742	0.1360	9.586	316.745
58	12:27:50	0.9	8.266	14.2340	0.9	5.842	0.1360	9.753	305.432
59	12:40:29	0.9	8.366	14.2340	0.9	5.942	0.1360	9.920	303.170
60	12:53:08	0.9	8.468	14.2340	0.9	6.044	0.1360	10.090	303.170
61	13:06:03	0.9	8.568	14.2340	0.9	6.144	0.1360	10.257	303.170
62	13:18:37	0.9	8.668	14.2340	0.9	6.244	0.1360	10.424	303.170
63	13:31:12	0.9	8.768	14.2340	0.9	6.344	0.1360	10.591	303.170
64	13:44:04	0.9	8.868	14.2360	0.9	6.444	0.1380	10.758	303.170
65	13:56:44	0.9	8.968	14.2360	0.9	6.544	0.1380	10.925	303.170
66	14:09:44	0.8	9.070	14.2360	0.8	6.646	0.1380	11.095	300.907
67	14:22:24	0.8	9.170	14.2360	0.8	6.746	0.1380	11.262	300.907
68	14:35:06	0.8	9.270	14.2360	0.8	6.846	0.1380	11.429	300.907
69	14:47:34	0.8	9.370	14.2360	0.8	6.946	0.1380	11.596	300.907
70	15:00:15	0.8	9.470	14.2380	0.8	7.046	0.1400	11.763	300.907
71	15:12:24	0.8	9.570	14.2380	0.8	7.146	0.1400	11.930	300.907
72	15:25:03	0.8	9.672	14.2380	0.8	7.248	0.1400	12.100	298.645
73	15:37:44	0.8	9.772	14.2380	0.8	7.348	0.1400	12.267	294.120
74	15:50:00	0.8	9.872	14.2380	0.8	7.448	0.1400	12.434	294.120
75	16:02:30	0.8	9.972	14.2380	0.8	7.548	0.1400	12.601	291.858
76	16:15:18	0.8	10.072	14.2380	0.8	7.648	0.1400	12.768	291.858
77	16:27:42	0.8	10.172	14.2380	0.8	7.748	0.1400	12.935	291.858
78	16:40:13	0.8	10.274	14.2380	0.8	7.850	0.1400	13.105	291.858
79	16:52:39	0.8	10.374	14.2380	0.8	7.950	0.1400	13.272	291.858
80	17:04:51	0.8	10.474	14.2380	0.8	8.050	0.1400	13.439	291.858
81	17:17:05	0.8	10.574	14.2380	0.8	8.150	0.1400	13.606	291.858
82	17:29:40	0.8	10.674	14.2380	0.8	8.250	0.1400	13.773	291.858
83	17:42:17	0.8	10.774	14.2380	0.8	8.350	0.1400	13.940	291.858
84	17:54:54	0.8	10.876	14.2380	0.8	8.452	0.1400	14.110	291.858
85	18:07:32	0.8	10.976	14.2380	0.8	8.552	0.1400	14.277	291.858
86	18:19:45	0.8	11.076	14.2380	0.8	8.652	0.1400	14.444	291.858
87	18:31:52	0.8	11.176	14.2380	0.8	8.752	0.1400	14.611	291.858
88	18:44:30	0.8	11.276	14.2380	0.8	8.852	0.1400	14.778	287.333
89	18:56:38	0.8	11.376	14.2380	0.8	8.952	0.1400	14.945	287.333
90	19:09:20	0.8	11.478	14.2380	0.8	9.054	0.1400	15.115	287.333
91	19:21:55	0.8	11.578	14.2380	0.8	9.154	0.1400	15.282	287.333
92	19:34:19	0.8	11.678	14.2380	0.8	9.254	0.1400	15.449	287.333
93	19:46:55	0.8	11.780	14.2380	0.8	9.356	0.1400	15.619	287.333
94	19:59:26	0.8	11.882	14.2400	0.8	9.458	0.1420	15.790	287.333
95	20:12:01	0.8	11.982	14.2400	0.8	9.558	0.1420	15.957	282.808
96	20:24:15	0.8	12.082	14.2400	0.8	9.658	0.1420	16.124	282.808
97	20:36:53	0.8	12.184	14.2400	0.8	9.760	0.1420	16.294	282.808
98	20:49:37	0.8	12.284	14.2400	0.8	9.860	0.1420	16.461	282.808
99	21:02:02	0.8	12.384	14.2400	0.8	9.960	0.1420	16.628	282.808
100	21:14:37	0.8	12.484	14.2400	0.8	10.060	0.1420	16.795	280.545
101	21:27:15	0.8	12.584	14.2400	0.8	10.160	0.1420	16.962	280.545
102	21:39:50	0.8	12.684	14.2440	0.8	10.260	0.1460	17.129	280.545
103	21:52:31	0.8	12.786	14.2440	0.8	10.362	0.1460	17.299	280.545
104	22:05:08	0.8	12.886	14.2440	0.8	10.462	0.1460	17.466	280.545
105	22:17:41	0.8	12.986	14.2440	0.8	10.562	0.1460	17.633	280.545

106	22:29:53	0.8	13.086	14.2440	0.8	10.662	0.1460	17.800	280.545
107	22:42:43	0.8	13.186	14.2440	0.8	10.762	0.1460	17.967	278.283
108	22:55:12	0.8	13.286	14.2440	0.8	10.862	0.1460	18.134	278.283
109	23:08:07	0.8	13.388	14.2440	0.8	10.964	0.1460	18.304	278.283
110	23:21:01	0.8	13.488	14.2440	0.8	11.064	0.1460	18.471	278.283
111	23:33:22	0.8	13.588	14.2440	0.8	11.164	0.1460	18.638	278.283
112	23:46:01	0.8	13.688	14.2440	0.8	11.264	0.1460	18.805	278.283
113	23:58:50	0.8	13.788	14.2440	0.8	11.364	0.1460	18.972	278.283
114	24:11:21	0.8	13.888	14.2440	0.8	11.464	0.1460	19.139	278.283
115	24:24:13	0.8	13.990	14.2440	0.8	11.566	0.1460	19.309	278.283
116	24:37:11	0.8	14.090	14.2440	0.8	11.666	0.1460	19.476	273.758
117	24:49:48	0.8	14.190	14.2440	0.8	11.766	0.1460	19.643	273.758
118	25:02:15	0.8	14.290	14.2440	0.8	11.866	0.1460	19.810	273.758
119	25:07:20	0.8	14.328	14.2440	0.8	11.904	0.1460	19.873	271.495

PASS 2

Reading Number	Time	Shear force Kn	Horizontal Deformation (mm)	Vertical Deformation (mm)	Shear Force Kn	Horizontal Deformation (mm)	Vertical Deformation (mm)	Axial Strain (%)	Stress (kPa)
0	00:00:00	0.0	0.182	14.0360	0.0	0.000	0.0000	0.000	0.000
1	00:20:03	0.1	0.284	14.0020	0.1	0.102	-0.0340	0.170	49.774
2	00:34:23	0.3	0.386	13.9920	0.3	0.204	-0.0440	0.341	90.498
3	00:48:30	0.3	0.490	13.9820	0.3	0.308	-0.0540	0.514	119.910
4	01:01:59	0.4	0.590	13.9720	0.4	0.408	-0.0640	0.681	144.798
5	01:14:52	0.5	0.690	13.9660	0.5	0.508	-0.0700	0.848	165.160
6	01:28:10	0.5	0.792	13.9620	0.5	0.610	-0.0740	1.018	185.522
7	01:41:07	0.6	0.894	13.9560	0.6	0.712	-0.0800	1.189	199.097
8	01:54:16	0.6	0.994	13.9520	0.6	0.812	-0.0840	1.356	210.409
9	02:06:55	0.6	1.096	13.9520	0.6	0.914	-0.0840	1.526	217.198
10	02:19:10	0.6	1.196	13.9480	0.6	1.014	-0.0880	1.693	226.246
11	02:31:56	0.7	1.296	13.9460	0.7	1.114	-0.0900	1.860	230.771
12	02:44:13	0.7	1.396	13.9460	0.7	1.214	-0.0900	2.027	235.296
13	02:56:41	0.7	1.496	13.9440	0.7	1.314	-0.0920	2.194	237.559
14	03:09:16	0.7	1.596	13.9440	0.7	1.414	-0.0920	2.361	237.559
15	03:21:40	0.7	1.696	13.9440	0.7	1.514	-0.0920	2.528	242.083
16	03:34:18	0.7	1.798	13.9420	0.7	1.616	-0.0940	2.698	242.083
17	03:46:51	0.7	1.898	13.9420	0.7	1.716	-0.0940	2.865	246.608
18	03:59:12	0.7	1.998	13.9420	0.7	1.816	-0.0940	3.032	248.871
19	04:11:41	0.7	2.098	13.9420	0.7	1.916	-0.0940	3.199	248.871
20	04:24:22	0.7	2.198	13.9420	0.7	2.016	-0.0940	3.366	248.871
21	04:36:53	0.7	2.298	13.9380	0.7	2.116	-0.0980	3.533	251.133
22	04:49:35	0.7	2.400	13.9380	0.7	2.218	-0.0980	3.703	251.133
23	05:02:26	0.7	2.500	13.9380	0.7	2.318	-0.0980	3.870	251.133
24	05:15:00	0.7	2.602	13.9380	0.7	2.420	-0.0980	4.040	251.133
25	05:27:18	0.7	2.702	13.9380	0.7	2.520	-0.0980	4.207	251.133
26	05:40:06	0.7	2.804	13.9360	0.7	2.622	-0.1000	4.377	251.133
27	05:52:44	0.7	2.904	13.9360	0.7	2.722	-0.1000	4.544	251.133
28	06:05:42	0.7	3.006	13.9360	0.7	2.824	-0.1000	4.715	251.133
29	06:18:37	0.7	3.108	13.9360	0.7	2.926	-0.1000	4.885	251.133
30	06:31:11	0.7	3.208	13.9360	0.7	3.026	-0.1000	5.052	251.133
31	06:44:01	0.7	3.308	13.9360	0.7	3.126	-0.1000	5.219	251.133
32	06:57:00	0.7	3.410	13.9360	0.7	3.228	-0.1000	5.389	251.133
33	07:09:42	0.7	3.510	13.9340	0.7	3.328	-0.1020	5.556	251.133
34	07:22:20	0.7	3.610	13.9340	0.7	3.428	-0.1020	5.723	251.133
35	07:35:16	0.7	3.712	13.9340	0.7	3.530	-0.1020	5.893	251.133
36	07:47:58	0.7	3.812	13.9340	0.7	3.630	-0.1020	6.060	251.133
37	08:01:02	0.7	3.914	13.9340	0.7	3.732	-0.1020	6.230	251.133

38	08:14:02	0.7	4.014	13.9340	0.7	3.832	-0.1020	6.397	251.133
39	08:26:36	0.7	4.114	13.9340	0.7	3.932	-0.1020	6.564	251.133
40	08:39:29	0.7	4.216	13.9340	0.7	4.034	-0.1020	6.735	251.133
41	08:52:09	0.7	4.318	13.9340	0.7	4.136	-0.1020	6.905	251.133
42	09:04:46	0.7	4.418	13.9340	0.7	4.236	-0.1020	7.072	251.133
43	09:17:07	0.7	4.518	13.9340	0.7	4.336	-0.1020	7.239	251.133
44	09:29:51	0.7	4.620	13.9340	0.7	4.438	-0.1020	7.409	251.133
45	09:42:39	0.7	4.720	13.9340	0.7	4.538	-0.1020	7.576	251.133
46	09:55:06	0.7	4.820	13.9340	0.7	4.638	-0.1020	7.743	251.133
47	10:07:53	0.7	4.922	13.9340	0.7	4.740	-0.1020	7.913	251.133
48	10:20:37	0.7	5.024	13.9340	0.7	4.842	-0.1020	8.083	251.133
49	10:33:06	0.7	5.124	13.9340	0.7	4.942	-0.1020	8.250	251.133
50	10:45:38	0.7	5.226	13.9340	0.7	5.044	-0.1020	8.421	251.133
51	10:57:56	0.7	5.326	13.9340	0.7	5.144	-0.1020	8.588	251.133
52	11:10:34	0.7	5.426	13.9340	0.7	5.244	-0.1020	8.755	251.133
53	11:23:07	0.7	5.528	13.9340	0.7	5.346	-0.1020	8.925	251.133
54	11:35:14	0.7	5.628	13.9340	0.7	5.446	-0.1020	9.092	251.133
55	11:47:51	0.7	5.730	13.9340	0.7	5.548	-0.1020	9.262	251.133
56	12:00:27	0.7	5.830	13.9360	0.7	5.648	-0.1000	9.429	251.133
57	12:12:40	0.7	5.930	13.9360	0.7	5.748	-0.1000	9.596	251.133
58	12:25:18	0.7	6.032	13.9360	0.7	5.850	-0.1000	9.766	251.133
59	12:37:55	0.7	6.134	13.9380	0.7	5.952	-0.0980	9.937	251.133
60	12:50:28	0.7	6.234	13.9380	0.7	6.052	-0.0980	10.104	251.133
61	13:02:45	0.7	6.334	13.9380	0.7	6.152	-0.0980	10.270	251.133
62	13:15:22	0.7	6.436	13.9380	0.7	6.254	-0.0980	10.441	251.133
63	13:27:59	0.7	6.536	13.9420	0.7	6.354	-0.0940	10.608	251.133
64	13:40:18	0.7	6.636	13.9420	0.7	6.454	-0.0940	10.775	251.133
65	13:52:34	0.7	6.736	13.9420	0.7	6.554	-0.0940	10.942	251.133
66	14:05:08	0.7	6.836	13.9440	0.7	6.654	-0.0920	11.109	251.133
67	14:17:32	0.7	6.936	13.9440	0.7	6.754	-0.0920	11.275	251.133
68	14:29:56	0.7	7.038	13.9440	0.7	6.856	-0.0920	11.446	251.133
69	14:42:35	0.7	7.138	13.9460	0.7	6.956	-0.0900	11.613	251.133
70	14:55:03	0.7	7.238	13.9460	0.7	7.056	-0.0900	11.780	251.133
71	15:07:31	0.7	7.338	13.9460	0.7	7.156	-0.0900	11.947	251.133
72	15:20:21	0.7	7.438	13.9480	0.7	7.256	-0.0880	12.114	251.133
73	15:33:02	0.7	7.540	13.9480	0.7	7.358	-0.0880	12.284	251.133
74	15:44:01	0.7	11.106	13.9900	0.7	10.924	-0.0460	18.237	248.871

Reviewed By: C. Lamoureux

Date: 2-Nov-16

Tested By: C. Woods

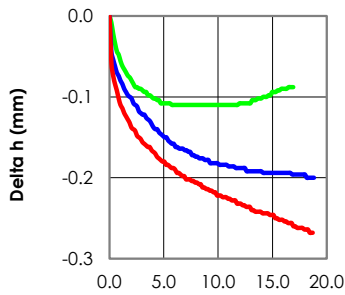
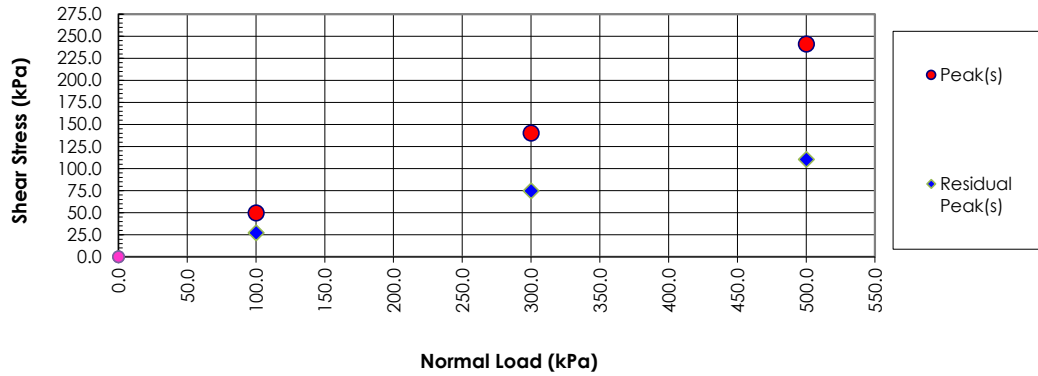

— Specimen A (100kPa)
— Specimen B (300kPa)
— Specimen C (500kPa)

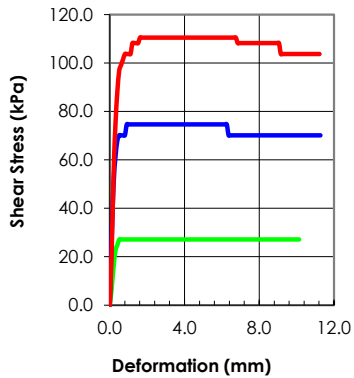

Initial	Specimen			
	A	B	C	D
Moisture (%)	25.8	25.8	25.8	
Density (g/cm ³)	1.544	1.549	1.518	
Void Ratio	0.716	0.711	0.746	
Saturation (%)	95.59	96.26	91.70	
Diameter (mm)	59.9	59.9	60.0	
Height (mm)	25.0	25.0	25.0	

Final	A	B	C	D
Moisture (%)	27.4	23.9	23.2	
Density (g/cm ³)	1.481	1.531	1.514	
Void Ratio	0.789	0.731	0.750	
Saturation (%)	98.84	95.32	95.86	
Diameter (mm)	59.9	59.9	60.0	
Height (mm)	24.22	24.03	23.46	
Normal Stress (kPa)	100.0	300.0	500.0	
Peak Stress (kPa)	49.8	140.3	241.3	
Residual Stress (kPa)	27.1	74.7	110.5	
Strain (%)	16.915	18.821	18.707	
Rate (mm/min)	0.008	0.008	0.008	

Project Date	
Date	2-Nov-16

Project:	Aurum Road Creek Crossing
Location:	
Project Number:	123312651
Boring Number	
Sample Number:	BH08 RC4
Depth:	7.6m
Sample Type:	Undisturbed
Description:	Brown Clay
Test Type:	Direct Shear
Remarks:	

Reporting of these test results constitutes a testing service only. Engineering interpretation or evaluation of the test results is provided only on written request. The data presented above is for the sole use of the client stipulated above. Stantec is not responsible, nor can be held liable, for the use of this report by any other party, with or without the knowledge of Stantec.

Delta h

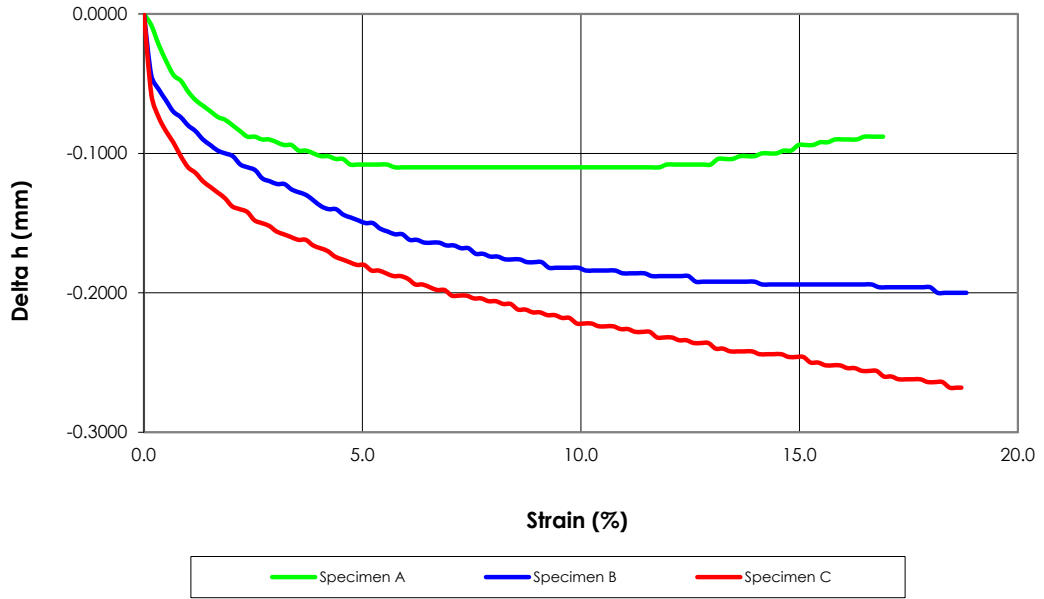

Stress-Deformation

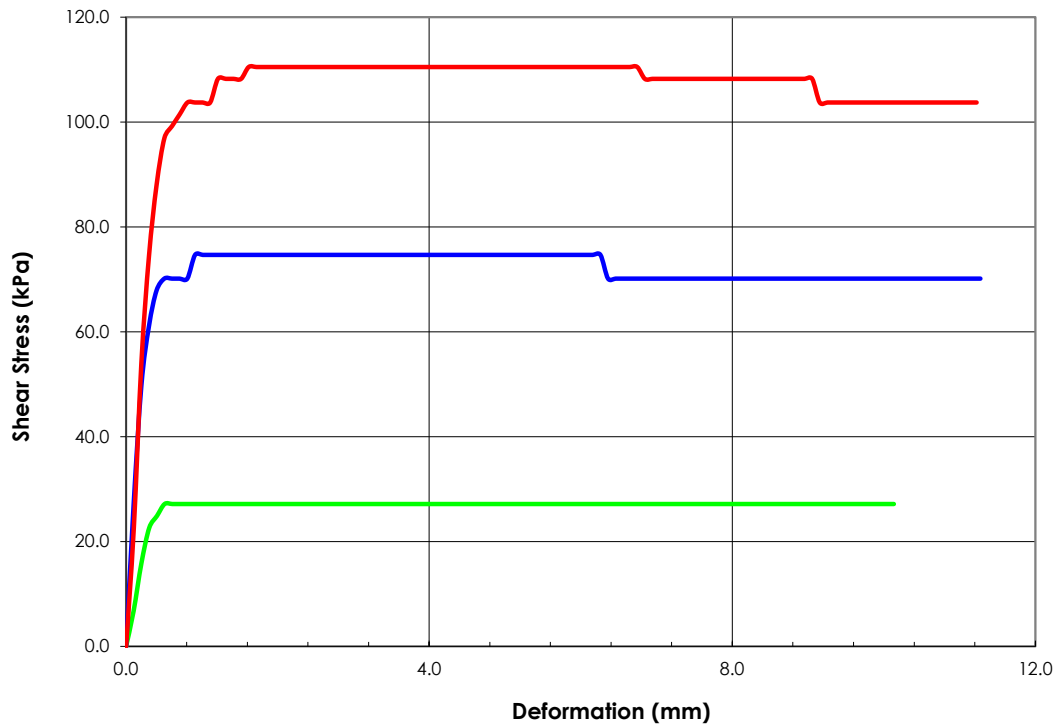

Specimen A Stress-Deformation

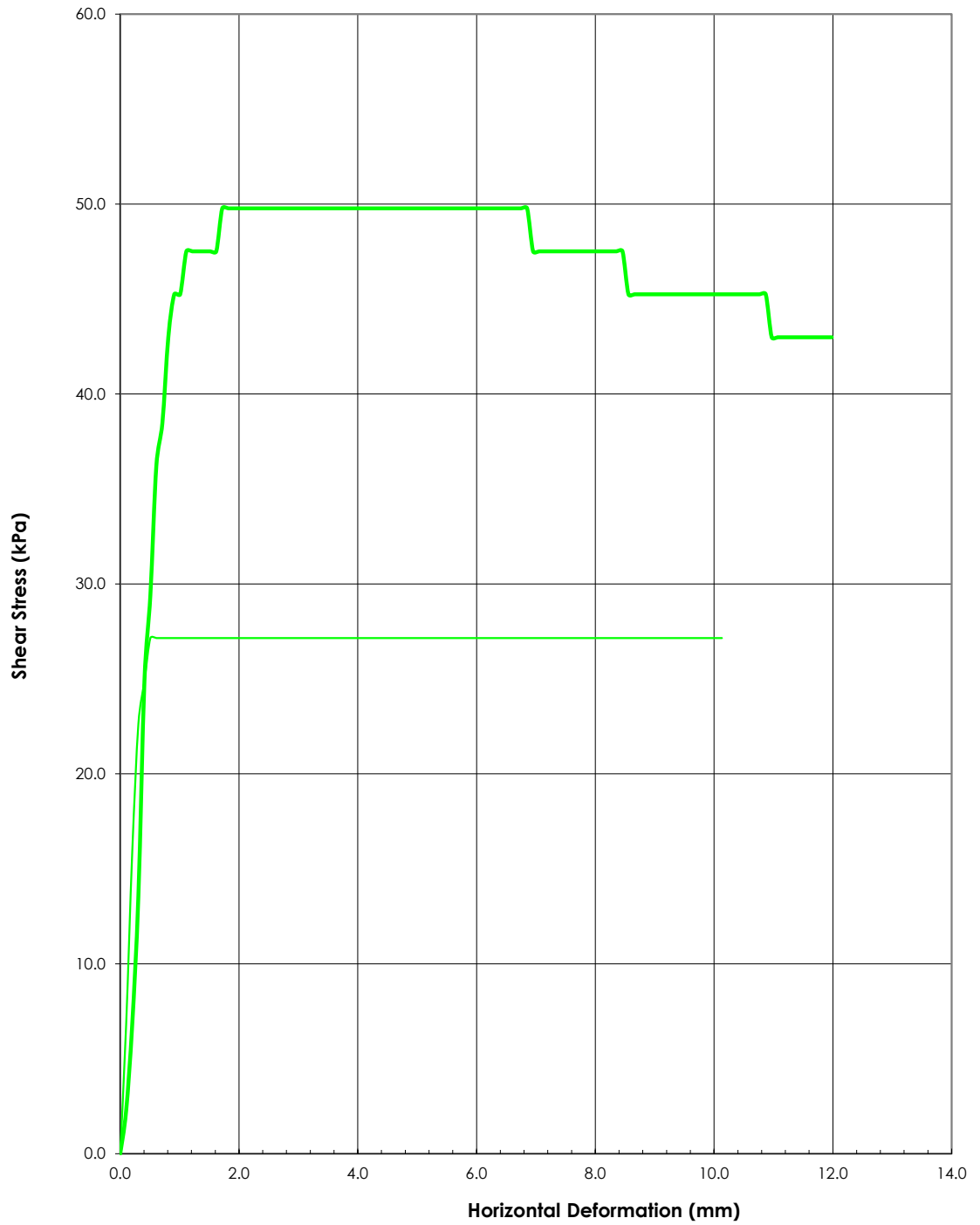

Specimen B Stress-Deformation

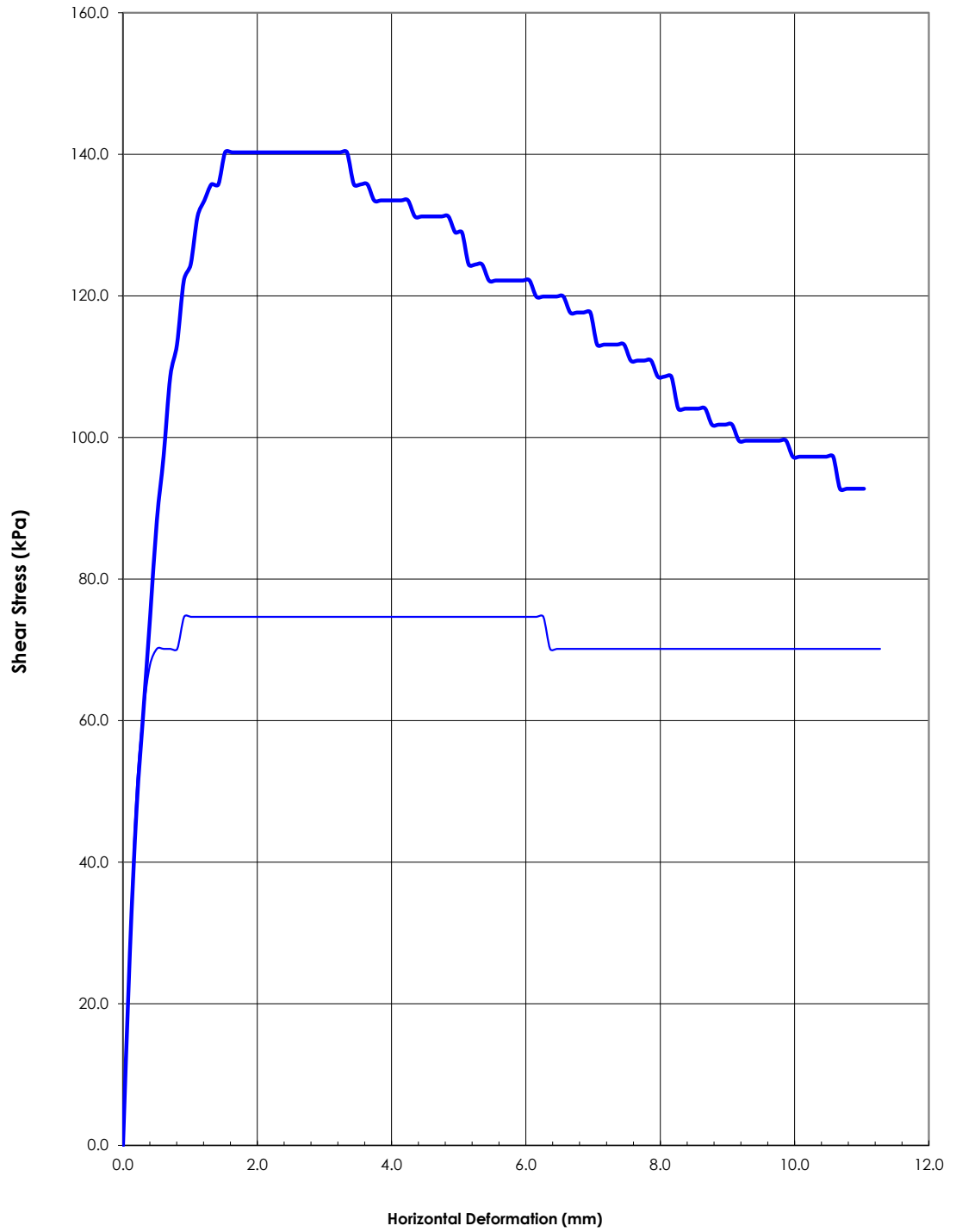

Specimen C Stress-Deformation

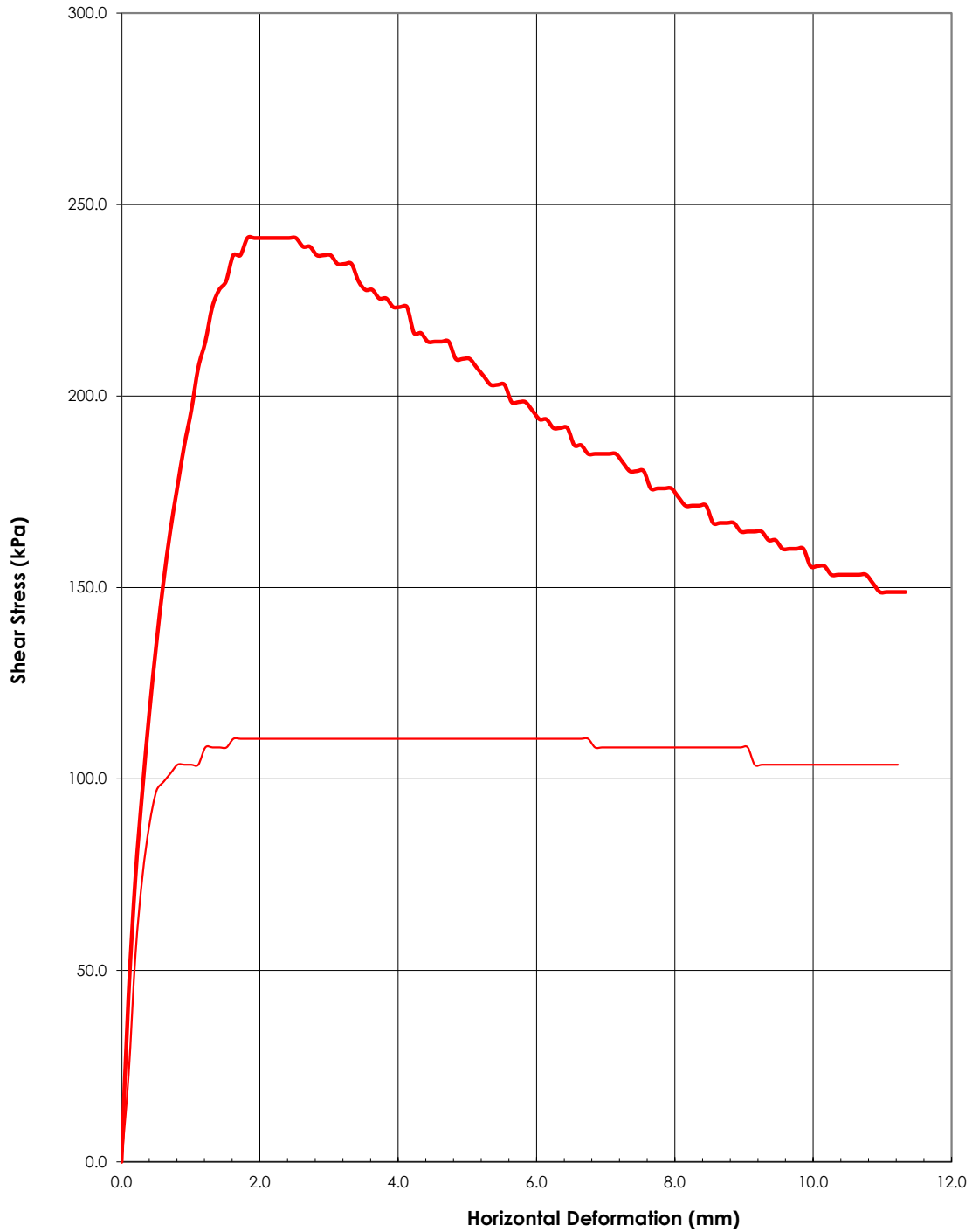

Specimen Information
Direct Shear Test

Stantec Consulting Ltd.

Project Information

Project: Aurum Road Creek Crossing
 Location:
 Project Number: 123312651
 Client:
 Sample Location:
 Sample Number: BH08 RC4
 Boring Number:

Tested By:
 Reduced By:
 Checked By:

Sample Description/Remarks	
Specimen A Description	Brown Clay
Remarks	
Specimen B Description	Brown Clay
Remarks	
Specimen C Description	Brown Clay
Remarks	
Specimen D Description	
Remarks	

Moisture Density Data

	Specimen A		Specimen B		Specimen C		Specimen D	
	Initial	Final	Initial	Final	Initial	Final	Initial	Final
Height (mm)	25.0	24.224	25.0	24.026	25.0	23.460		
Diameter (mm)	59.9	59.9	59.9	59.9	60.0	60.0		
Total Wet Weight of Ring & Soil (g)	2048.6	2044.6	2043.4	2039.7	2046.3	2043.2		
Weight of Ring (g)	1911.7	1911.7	1906.1	1906.1	1911.3	1911.3		
Wet Weight of Soil (g)	136.9	132.9	137.3	133.6	135.0	131.9		
Wt of Wet Soil & Dish (g)	-	139.22	-	138.28	-	135.27		
Wt of Dry Soil & Dish (g)	-	109.65	-	111.93	-	110.06		
Wt. Of Dish (g)	-	1.58	-	1.51	-	1.56		

Consolidation Calculations

	Specimen A	Specimen B	Specimen C	Specimen D
Initial Ref. Height (mm)	14.544	14.376	14.482	
Final Ref. Height (mm)	13.768	13.402	12.942	
Height after Consol (mm)	24.224	24.026	23.460	

Calculations

	Specimen A		Specimen B		Specimen C		Specimen D	
	Initial	Final	Initial	Final	Initial	Final	Initial	Final
Specific Gravity	2.65	2.65	2.65	2.65	2.65	2.65		
Area (cm2)	28.180	28.180	28.180	28.180	28.274	28.274		
Volume (cm3)	70.5	70.5	70.5	70.5	70.7	70.7		
Moisture Content (%)	25.8	27.4	25.8	23.9	25.8	23.2		
Wet Density (g/cm3)	1.943	1.886	1.949	1.896	1.910	1.866		
Dry Density (g/cm3)	1.544	1.481	1.549	1.531	1.518	1.514		
Saturation (%)	95.586	98.839	96.256	95.318	91.700	95.861		
Void Ratio	0.716	0.789	0.711	0.731	0.746	0.750		
Porosity (%)	41.720	42.317	41.549	39.884	42.709	39.110		

Specimen A Shear Data**Direct Shear Test**

Stantec Consulting Ltd.

File Location

lab_123312651_dsh_bh08rc4.HSD

Last Shear Pass

Reading Number	Time	Shear Force Kn	Horizontal Deformation (mm)	Vertical Deformation (mm)	Axial Strain (%)	Stress (kPa)
0	00:00:00	0.000	0.000	0.0000	0.000	0.000
1	00:19:31	0.019	0.100	-0.0080	0.167	6.787
2	00:32:45	0.045	0.202	-0.0220	0.337	15.837
3	00:46:18	0.064	0.306	-0.0340	0.511	22.625
4	00:59:31	0.070	0.408	-0.0440	0.681	24.887
5	01:12:49	0.077	0.508	-0.0480	0.848	27.150
6	01:25:57	0.077	0.610	-0.0560	1.018	27.150
7	01:38:48	0.077	0.712	-0.0620	1.189	27.150
8	01:51:50	0.077	0.814	-0.0660	1.359	27.150
9	02:04:44	0.077	0.916	-0.0700	1.529	27.150
10	02:17:34	0.077	1.016	-0.0740	1.696	27.150
11	02:30:10	0.077	1.116	-0.0760	1.863	27.150
12	02:43:02	0.077	1.218	-0.0800	2.033	27.150
13	02:55:55	0.077	1.318	-0.0840	2.200	27.150
14	03:08:35	0.077	1.418	-0.0880	2.367	27.150
15	03:20:58	0.077	1.518	-0.0880	2.534	27.150
16	03:33:58	0.077	1.618	-0.0900	2.701	27.150
17	03:46:36	0.077	1.718	-0.0900	2.868	27.150
18	03:59:37	0.077	1.820	-0.0920	3.038	27.150
19	04:12:20	0.077	1.920	-0.0940	3.205	27.150
20	04:24:54	0.077	2.022	-0.0940	3.376	27.150
21	04:37:28	0.077	2.122	-0.0980	3.543	27.150
22	04:50:02	0.077	2.224	-0.0980	3.713	27.150
23	05:02:40	0.077	2.324	-0.1000	3.880	27.150
24	05:15:02	0.077	2.424	-0.1020	4.047	27.150
25	05:27:46	0.077	2.526	-0.1020	4.217	27.150
26	05:40:22	0.077	2.628	-0.1040	4.387	27.150
27	05:52:47	0.077	2.728	-0.1040	4.554	27.150
28	06:04:52	0.077	2.828	-0.1080	4.721	27.150
29	06:17:36	0.077	2.930	-0.1080	4.891	27.150
30	06:30:20	0.077	3.030	-0.1080	5.058	27.150
31	06:42:28	0.077	3.130	-0.1080	5.225	27.150
32	06:55:11	0.077	3.232	-0.1080	5.396	27.150
33	07:07:53	0.077	3.334	-0.1080	5.566	27.150
34	07:20:30	0.077	3.438	-0.1100	5.740	27.150
35	07:32:50	0.077	3.538	-0.1100	5.907	27.150
36	07:45:19	0.077	3.640	-0.1100	6.077	27.150
37	07:57:27	0.077	3.740	-0.1100	6.244	27.150
38	08:10:07	0.077	3.842	-0.1100	6.414	27.150
39	08:22:44	0.077	3.942	-0.1100	6.581	27.150
40	08:35:24	0.077	4.042	-0.1100	6.748	27.150
41	08:48:05	0.077	4.144	-0.1100	6.918	27.150
42	09:00:42	0.077	4.246	-0.1100	7.088	27.150
43	09:13:25	0.077	4.346	-0.1100	7.255	27.150
44	09:25:48	0.077	4.446	-0.1100	7.422	27.150
45	09:38:28	0.077	4.548	-0.1100	7.593	27.150

46	09:51:07	0.077	4.648	-0.1100	7.760	27.150
47	10:03:33	0.077	4.748	-0.1100	7.927	27.150
48	10:16:22	0.077	4.850	-0.1100	8.097	27.150
49	10:28:55	0.077	4.952	-0.1100	8.267	27.150
50	10:41:41	0.077	5.052	-0.1100	8.434	27.150
51	10:54:08	0.077	5.152	-0.1100	8.601	27.150
52	11:06:48	0.077	5.254	-0.1100	8.771	27.150
53	11:19:37	0.077	5.356	-0.1100	8.942	27.150
54	11:32:22	0.077	5.456	-0.1100	9.109	27.150
55	11:45:02	0.077	5.556	-0.1100	9.275	27.150
56	11:57:56	0.077	5.658	-0.1100	9.446	27.150
57	12:10:54	0.077	5.758	-0.1100	9.613	27.150
58	12:23:39	0.077	5.858	-0.1100	9.780	27.150
59	12:35:52	0.077	5.958	-0.1100	9.947	27.150
60	12:48:58	0.077	6.058	-0.1100	10.114	27.150
61	13:01:21	0.077	6.158	-0.1100	10.280	27.150
62	13:14:13	0.077	6.260	-0.1100	10.451	27.150
63	13:27:06	0.077	6.360	-0.1100	10.618	27.150
64	13:39:44	0.077	6.460	-0.1100	10.785	27.150
65	13:52:35	0.077	6.562	-0.1100	10.955	27.150
66	14:05:26	0.077	6.664	-0.1100	11.125	27.150
67	14:18:20	0.077	6.764	-0.1100	11.292	27.150
68	14:30:55	0.077	6.864	-0.1100	11.459	27.150
69	14:43:33	0.077	6.966	-0.1100	11.629	27.150
70	14:56:11	0.077	7.066	-0.1100	11.796	27.150
71	15:08:35	0.077	7.166	-0.1080	11.963	27.150
72	15:20:55	0.077	7.266	-0.1080	12.130	27.150
73	15:33:45	0.077	7.366	-0.1080	12.297	27.150
74	15:46:11	0.077	7.466	-0.1080	12.464	27.150
75	15:58:58	0.077	7.568	-0.1080	12.634	27.150
76	16:11:38	0.077	7.668	-0.1080	12.801	27.150
77	16:24:01	0.077	7.768	-0.1080	12.968	27.150
78	16:36:09	0.077	7.868	-0.1040	13.135	27.150
79	16:48:48	0.077	7.968	-0.1040	13.302	27.150
80	17:01:02	0.077	8.068	-0.1040	13.469	27.150
81	17:13:44	0.077	8.170	-0.1020	13.639	27.150
82	17:26:28	0.077	8.270	-0.1020	13.806	27.150
83	17:38:51	0.077	8.370	-0.1020	13.973	27.150
84	17:51:13	0.077	8.470	-0.1000	14.140	27.150
85	18:03:36	0.077	8.570	-0.1000	14.307	27.150
86	18:15:32	0.077	8.670	-0.1000	14.474	27.150
87	18:28:03	0.077	8.772	-0.0980	14.644	27.150
88	18:40:40	0.077	8.872	-0.0980	14.811	27.150
89	18:53:01	0.077	8.972	-0.0940	14.978	27.150
90	19:05:38	0.077	9.072	-0.0940	15.145	27.150
91	19:18:24	0.077	9.172	-0.0940	15.312	27.150
92	19:31:03	0.077	9.272	-0.0920	15.479	27.150
93	19:43:34	0.077	9.374	-0.0920	15.649	27.150
94	19:56:06	0.077	9.474	-0.0900	15.816	27.150
95	20:08:17	0.077	9.574	-0.0900	15.983	27.150
96	20:20:27	0.077	9.674	-0.0900	16.150	27.150
97	20:33:17	0.077	9.774	-0.0900	16.317	27.150
98	20:45:43	0.077	9.874	-0.0880	16.484	27.150
99	20:58:32	0.077	9.976	-0.0880	16.654	27.150
100	21:11:06	0.077	10.076	-0.0880	16.821	27.150
101	21:18:22	0.077	10.132	-0.0880	16.915	27.150

Specimen B Shear Data**Direct Shear Test**

Stantec Consulting Ltd.

File Location

lab_123312651_dsh_bh08rc4.HSD

Last Shear Pass

Reading Number	Time	Shear Force Kn	Horizontal Deformation (mm)	Vertical Deformation (mm)	Axial Strain (%)	Stress (kPa)
0	00:00:00	0.000	0.000	0.0000	0.000	0.000
1	00:22:20	0.077	0.100	-0.0440	0.167	27.150
2	00:36:25	0.140	0.202	-0.0540	0.337	49.774
3	00:50:00	0.172	0.302	-0.0620	0.504	61.086
4	01:02:48	0.191	0.402	-0.0700	0.671	67.874
5	01:15:50	0.198	0.504	-0.0740	0.841	70.136
6	01:28:45	0.198	0.606	-0.0800	1.012	70.136
7	01:41:41	0.198	0.706	-0.0840	1.179	70.136
8	01:54:39	0.198	0.808	-0.0900	1.349	70.136
9	02:07:35	0.210	0.910	-0.0940	1.519	74.661
10	02:20:26	0.210	1.012	-0.0980	1.689	74.661
11	02:33:20	0.210	1.114	-0.1000	1.860	74.661
12	02:46:38	0.210	1.218	-0.1020	2.033	74.661
13	02:59:56	0.210	1.322	-0.1080	2.207	74.661
14	03:12:53	0.210	1.422	-0.1100	2.374	74.661
15	03:25:42	0.210	1.524	-0.1120	2.544	74.661
16	03:38:25	0.210	1.624	-0.1180	2.711	74.661
17	03:51:17	0.210	1.726	-0.1200	2.881	74.661
18	04:04:18	0.210	1.826	-0.1220	3.048	74.661
19	04:17:01	0.210	1.926	-0.1220	3.215	74.661
20	04:29:58	0.210	2.028	-0.1260	3.386	74.661
21	04:42:58	0.210	2.130	-0.1280	3.556	74.661
22	04:55:38	0.210	2.230	-0.1300	3.723	74.661
23	05:08:01	0.210	2.330	-0.1340	3.890	74.661
24	05:20:51	0.210	2.432	-0.1380	4.060	74.661
25	05:33:25	0.210	2.532	-0.1400	4.227	74.661
26	05:46:05	0.210	2.632	-0.1400	4.394	74.661
27	05:58:51	0.210	2.734	-0.1440	4.564	74.661
28	06:11:31	0.210	2.836	-0.1460	4.735	74.661
29	06:24:11	0.210	2.936	-0.1480	4.902	74.661
30	06:36:48	0.210	3.038	-0.1500	5.072	74.661
31	06:49:15	0.210	3.138	-0.1500	5.239	74.661
32	07:01:38	0.210	3.238	-0.1540	5.406	74.661
33	07:14:16	0.210	3.340	-0.1560	5.576	74.661
34	07:26:27	0.210	3.440	-0.1580	5.743	74.661
35	07:39:04	0.210	3.542	-0.1580	5.913	74.661
36	07:51:49	0.210	3.642	-0.1620	6.080	74.661
37	08:03:58	0.210	3.742	-0.1620	6.247	74.661
38	08:16:45	0.210	3.844	-0.1640	6.417	74.661
39	08:29:08	0.210	3.946	-0.1640	6.588	74.661
40	08:41:35	0.210	4.046	-0.1640	6.755	74.661
41	08:53:48	0.210	4.146	-0.1660	6.922	74.661
42	09:06:15	0.210	4.248	-0.1660	7.092	74.661
43	09:18:48	0.210	4.348	-0.1680	7.259	74.661
44	09:31:13	0.210	4.448	-0.1680	7.426	74.661
45	09:43:35	0.210	4.548	-0.1720	7.593	74.661

46	09:56:21	0.210	4.648	-0.1720	7.760	74.661
47	10:08:36	0.210	4.748	-0.1740	7.927	74.661
48	10:21:17	0.210	4.850	-0.1740	8.097	74.661
49	10:33:55	0.210	4.950	-0.1760	8.264	74.661
50	10:46:26	0.210	5.050	-0.1760	8.431	74.661
51	10:58:51	0.210	5.150	-0.1760	8.598	74.661
52	11:11:24	0.210	5.250	-0.1780	8.765	74.661
53	11:24:17	0.210	5.352	-0.1780	8.935	74.661
54	11:36:25	0.210	5.452	-0.1780	9.102	74.661
55	11:49:09	0.210	5.552	-0.1820	9.269	74.661
56	12:01:24	0.210	5.652	-0.1820	9.436	74.661
57	12:14:07	0.210	5.754	-0.1820	9.606	74.661
58	12:26:54	0.210	5.856	-0.1820	9.776	74.661
59	12:39:38	0.210	5.956	-0.1820	9.943	74.661
60	12:52:26	0.210	6.056	-0.1840	10.110	74.661
61	13:05:26	0.210	6.158	-0.1840	10.280	74.661
62	13:18:12	0.210	6.260	-0.1840	10.451	74.661
63	13:31:18	0.198	6.360	-0.1840	10.618	70.136
64	13:43:54	0.198	6.460	-0.1840	10.785	70.136
65	13:56:47	0.198	6.562	-0.1860	10.955	70.136
66	14:09:39	0.198	6.662	-0.1860	11.122	70.136
67	14:22:11	0.198	6.762	-0.1860	11.289	70.136
68	14:34:56	0.198	6.862	-0.1860	11.456	70.136
69	14:47:47	0.198	6.962	-0.1880	11.623	70.136
70	15:00:29	0.198	7.062	-0.1880	11.790	70.136
71	15:13:25	0.198	7.164	-0.1880	11.960	70.136
72	15:26:09	0.198	7.264	-0.1880	12.127	70.136
73	15:38:33	0.198	7.364	-0.1880	12.294	70.136
74	15:50:40	0.198	7.464	-0.1880	12.461	70.136
75	16:03:28	0.198	7.564	-0.1920	12.628	70.136
76	16:15:40	0.198	7.664	-0.1920	12.795	70.136
77	16:28:20	0.198	7.766	-0.1920	12.965	70.136
78	16:41:09	0.198	7.866	-0.1920	13.132	70.136
79	16:53:38	0.198	7.966	-0.1920	13.299	70.136
80	17:06:17	0.198	8.068	-0.1920	13.469	70.136
81	17:18:56	0.198	8.170	-0.1920	13.639	70.136
82	17:31:38	0.198	8.270	-0.1920	13.806	70.136
83	17:43:55	0.198	8.370	-0.1920	13.973	70.136
84	17:56:24	0.198	8.472	-0.1940	14.144	70.136
85	18:09:06	0.198	8.572	-0.1940	14.311	70.136
86	18:21:28	0.198	8.672	-0.1940	14.477	70.136
87	18:33:44	0.198	8.772	-0.1940	14.644	70.136
88	18:46:17	0.198	8.872	-0.1940	14.811	70.136
89	18:58:45	0.198	8.972	-0.1940	14.978	70.136
90	19:11:15	0.198	9.074	-0.1940	15.149	70.136
91	19:23:35	0.198	9.174	-0.1940	15.316	70.136
92	19:35:47	0.198	9.274	-0.1940	15.482	70.136
93	19:47:49	0.198	9.374	-0.1940	15.649	70.136
94	20:00:30	0.198	9.474	-0.1940	15.816	70.136
95	20:12:42	0.198	9.574	-0.1940	15.983	70.136
96	20:25:25	0.198	9.676	-0.1940	16.154	70.136
97	20:38:09	0.198	9.776	-0.1940	16.321	70.136
98	20:50:23	0.198	9.876	-0.1940	16.487	70.136
99	21:02:45	0.198	9.976	-0.1940	16.654	70.136
100	21:15:18	0.198	10.076	-0.1960	16.821	70.136
101	21:27:42	0.198	10.176	-0.1960	16.988	70.136
102	21:40:23	0.198	10.278	-0.1960	17.159	70.136

103	21:52:56	0.198	10.378	-0.1960	17.326	70.136
104	22:05:19	0.198	10.478	-0.1960	17.492	70.136
105	22:17:46	0.198	10.578	-0.1960	17.659	70.136
106	22:30:18	0.198	10.678	-0.1960	17.826	70.136
107	22:42:42	0.198	10.778	-0.1960	17.993	70.136
108	22:55:20	0.198	10.880	-0.2000	18.164	70.136
109	23:08:06	0.198	10.980	-0.2000	18.331	70.136
110	23:20:25	0.198	11.080	-0.2000	18.497	70.136
111	23:32:51	0.198	11.180	-0.2000	18.664	70.136
112	23:45:06	0.198	11.274	-0.2000	18.821	70.136

Specimen C Shear Data	Stantec Consulting Ltd.
Direct Shear Test	

File Location
lab_123312651_dsh_bh08rc4.HSD

Last Shear Pass

Reading Number	Time	Shear Force Kn	Horizontal Deformation (mm)	Vertical Deformation (mm)	Axial Strain (%)	Stress (kPa)
0	00:00:00	0.000	0.000	0.0000	0.000	0.000
1	00:19:38	0.064	0.102	-0.0580	0.170	22.549
2	00:34:17	0.153	0.202	-0.0740	0.337	54.118
3	00:47:58	0.210	0.302	-0.0840	0.503	74.413
4	01:01:03	0.249	0.402	-0.0920	0.670	87.942
5	01:14:55	0.274	0.506	-0.1020	0.843	96.962
6	01:28:09	0.281	0.606	-0.1100	1.010	99.217
7	01:41:20	0.287	0.708	-0.1140	1.180	101.472
8	01:54:31	0.293	0.810	-0.1200	1.350	103.727
9	02:06:51	0.293	0.910	-0.1240	1.517	103.727
10	02:19:50	0.293	1.010	-0.1280	1.683	103.727
11	02:32:18	0.293	1.110	-0.1320	1.850	103.727
12	02:45:04	0.306	1.212	-0.1380	2.020	108.236
13	02:58:21	0.306	1.316	-0.1400	2.193	108.236
14	03:11:20	0.306	1.418	-0.1420	2.363	108.236
15	03:24:21	0.306	1.518	-0.1480	2.530	108.236
16	03:36:50	0.312	1.618	-0.1500	2.697	110.491
17	03:49:49	0.312	1.720	-0.1520	2.867	110.491
18	04:02:40	0.312	1.820	-0.1560	3.033	110.491
19	04:15:16	0.312	1.920	-0.1580	3.200	110.491
20	04:27:30	0.312	2.020	-0.1600	3.367	110.491
21	04:40:17	0.312	2.120	-0.1620	3.533	110.491
22	04:52:59	0.312	2.222	-0.1620	3.703	110.491
23	05:05:22	0.312	2.322	-0.1660	3.870	110.491
24	05:18:12	0.312	2.422	-0.1680	4.037	110.491
25	05:30:34	0.312	2.522	-0.1700	4.203	110.491
26	05:43:05	0.312	2.622	-0.1740	4.370	110.491
27	05:55:33	0.312	2.722	-0.1760	4.537	110.491
28	06:07:54	0.312	2.822	-0.1780	4.703	110.491
29	06:20:29	0.312	2.924	-0.1800	4.873	110.491
30	06:33:05	0.312	3.024	-0.1800	5.040	110.491
31	06:45:10	0.312	3.124	-0.1840	5.207	110.491
32	06:57:20	0.312	3.224	-0.1840	5.373	110.491
33	07:09:59	0.312	3.324	-0.1860	5.540	110.491
34	07:22:36	0.312	3.426	-0.1880	5.710	110.491
35	07:34:51	0.312	3.526	-0.1880	5.877	110.491
36	07:47:25	0.312	3.626	-0.1900	6.043	110.491
37	07:59:35	0.312	3.726	-0.1940	6.210	110.491
38	08:11:47	0.312	3.826	-0.1940	6.377	110.491
39	08:24:09	0.312	3.926	-0.1960	6.543	110.491
40	08:36:26	0.312	4.026	-0.1980	6.710	110.491
41	08:49:04	0.312	4.128	-0.1980	6.880	110.491
42	09:01:41	0.312	4.228	-0.2020	7.047	110.491
43	09:14:08	0.312	4.328	-0.2020	7.213	110.491
44	09:26:45	0.312	4.430	-0.2020	7.383	110.491
45	09:39:24	0.312	4.532	-0.2040	7.553	110.491

46	09:52:00	0.312	4.632	-0.2040	7.720	110.491
47	10:04:18	0.312	4.732	-0.2060	7.887	110.491
48	10:17:00	0.312	4.834	-0.2060	8.057	110.491
49	10:29:42	0.312	4.934	-0.2080	8.223	110.491
50	10:42:30	0.312	5.036	-0.2080	8.393	110.491
51	10:54:50	0.312	5.136	-0.2120	8.560	110.491
52	11:07:35	0.312	5.238	-0.2120	8.730	110.491
53	11:20:17	0.312	5.338	-0.2140	8.897	110.491
54	11:32:28	0.312	5.438	-0.2140	9.063	110.491
55	11:45:14	0.312	5.540	-0.2160	9.233	110.491
56	11:58:01	0.312	5.642	-0.2160	9.403	110.491
57	12:10:56	0.312	5.742	-0.2180	9.570	110.491
58	12:23:45	0.312	5.842	-0.2180	9.737	110.491
59	12:36:46	0.312	5.944	-0.2220	9.907	110.491
60	12:49:39	0.312	6.044	-0.2220	10.073	110.491
61	13:02:10	0.312	6.144	-0.2220	10.240	110.491
62	13:14:43	0.312	6.244	-0.2240	10.407	110.491
63	13:27:30	0.312	6.344	-0.2240	10.573	110.491
64	13:40:04	0.312	6.444	-0.2240	10.740	110.491
65	13:53:03	0.312	6.546	-0.2260	10.910	110.491
66	14:06:05	0.312	6.646	-0.2260	11.077	110.491
67	14:18:47	0.312	6.746	-0.2280	11.243	110.491
68	14:31:19	0.306	6.846	-0.2280	11.410	108.236
69	14:44:02	0.306	6.946	-0.2280	11.577	108.236
70	14:56:14	0.306	7.046	-0.2320	11.743	108.236
71	15:08:52	0.306	7.148	-0.2320	11.913	108.236
72	15:21:38	0.306	7.248	-0.2320	12.080	108.236
73	15:34:00	0.306	7.348	-0.2340	12.247	108.236
74	15:46:23	0.306	7.448	-0.2340	12.413	108.236
75	15:59:13	0.306	7.548	-0.2360	12.580	108.236
76	16:11:35	0.306	7.648	-0.2360	12.747	108.236
77	16:24:15	0.306	7.750	-0.2360	12.917	108.236
78	16:36:56	0.306	7.850	-0.2400	13.083	108.236
79	16:49:10	0.306	7.950	-0.2400	13.250	108.236
80	17:01:26	0.306	8.050	-0.2420	13.417	108.236
81	17:14:00	0.306	8.150	-0.2420	13.583	108.236
82	17:26:27	0.306	8.250	-0.2420	13.750	108.236
83	17:38:59	0.306	8.352	-0.2420	13.920	108.236
84	17:51:36	0.306	8.452	-0.2440	14.087	108.236
85	18:04:01	0.306	8.552	-0.2440	14.253	108.236
86	18:16:06	0.306	8.652	-0.2440	14.420	108.236
87	18:28:40	0.306	8.752	-0.2440	14.587	108.236
88	18:40:40	0.306	8.852	-0.2460	14.753	108.236
89	18:53:13	0.306	8.954	-0.2460	14.923	108.236
90	19:05:44	0.306	9.054	-0.2460	15.090	108.236
91	19:18:06	0.293	9.154	-0.2500	15.257	103.727
92	19:30:49	0.293	9.256	-0.2500	15.427	103.727
93	19:43:31	0.293	9.358	-0.2520	15.597	103.727
94	19:56:13	0.293	9.458	-0.2520	15.763	103.727
95	20:08:39	0.293	9.558	-0.2520	15.930	103.727
96	20:21:16	0.293	9.660	-0.2540	16.100	103.727
97	20:33:55	0.293	9.760	-0.2540	16.267	103.727
98	20:46:14	0.293	9.860	-0.2560	16.433	103.727
99	20:58:44	0.293	9.960	-0.2560	16.600	103.727
100	21:11:30	0.293	10.060	-0.2560	16.767	103.727
101	21:24:01	0.293	10.160	-0.2600	16.933	103.727
102	21:36:53	0.293	10.262	-0.2600	17.103	103.727

103	21:49:33	0.293	10.362	-0.2620	17.270	103.727
104	22:02:04	0.293	10.462	-0.2620	17.437	103.727
105	22:14:14	0.293	10.562	-0.2620	17.603	103.727
106	22:26:57	0.293	10.662	-0.2620	17.770	103.727
107	22:39:27	0.293	10.762	-0.2640	17.937	103.727
108	22:52:26	0.293	10.864	-0.2640	18.107	103.727
109	23:05:32	0.293	10.964	-0.2640	18.273	103.727
110	23:18:09	0.293	11.064	-0.2680	18.440	103.727
111	23:30:43	0.293	11.164	-0.2680	18.607	103.727
112	23:38:38	0.293	11.224	-0.2680	18.707	103.727

Specimen A Consolidation**Direct Shear Test**

Stantec Consulting Ltd.

File Location

lab_123312651_dsh_bh08rc4.HSD

Last Consolidation Sequence

Reading Number	Time	Disp. (mm)	Settlement (mm)	Void Ratio
0.0	00:00:00	0.5726	0.0000	0.7159
1.0	00:00:01	0.5554	0.0172	0.6841
2.0	00:00:02	0.5487	0.0239	0.6726
3.0	00:00:03	0.5479	0.0247	0.6711
4.0	00:00:04	0.5476	0.0250	0.6706
5.0	00:00:05	0.5472	0.0254	0.6700
6.0	00:00:06	0.5471	0.0255	0.6698
7.0	00:00:12	0.5465	0.0261	0.6687
8.0	00:00:15	0.5464	0.0262	0.6685
9.0	00:00:30	0.5458	0.0268	0.6676
10.0	00:01:01	0.5453	0.0273	0.6666
11.0	00:02:01	0.5449	0.0277	0.6659
12.0	00:04:01	0.5445	0.0281	0.6652
13.0	00:08:01	0.5443	0.0283	0.6648
14.0	00:15:02	0.5439	0.0287	0.6643
15.0	00:30:03	0.5436	0.0290	0.6637
16.0	01:00:05	0.5434	0.0292	0.6633
17.0	02:00:10	0.5430	0.0296	0.6626
18.0	04:00:20	0.5427	0.0299	0.6621
19.0	08:00:40	0.5424	0.0302	0.6615
20.0	23:42:50	0.5420	0.0306	0.6610

Specimen B Consolidation**Direct Shear Test**

Stantec Consulting Ltd.

File Location

lab_123312651_dsh_bh08rc4.HSD

Last Consolidation Sequence

Reading Number	Time	Disp. (mm)	Settlement (mm)	Void Ratio
0.0	00:00:00	0.0000	0.0000	0.7109
1.0	00:00:01	0.5660	-0.5660	1.6999
2.0	00:00:02	0.5460	-0.5460	1.6651
3.0	00:00:03	0.5406	-0.5406	1.6556
4.0	00:00:04	0.5395	-0.5395	1.6538
5.0	00:00:05	0.5389	-0.5389	1.6527
6.0	00:00:06	0.5384	-0.5384	1.6519
7.0	00:00:12	0.5369	-0.5369	1.6493
8.0	00:00:15	0.5365	-0.5365	1.6486
9.0	00:00:30	0.5354	-0.5354	1.6467
10.0	00:01:00	0.5343	-0.5343	1.6446
11.0	00:02:00	0.5332	-0.5332	1.6429
12.0	00:04:00	0.5324	-0.5324	1.6413
13.0	00:08:00	0.5315	-0.5315	1.6398
14.0	00:15:01	0.5309	-0.5309	1.6387
15.0	00:30:02	0.5302	-0.5302	1.6375
16.0	01:00:04	0.5297	-0.5297	1.6367
17.0	02:00:08	0.5291	-0.5291	1.6357
18.0	04:00:16	0.5287	-0.5287	1.6349
19.0	08:00:32	0.5283	-0.5283	1.6344
20.0	24:01:35	0.5278	-0.5278	1.6334
21.0	28:53:42	0.5276	-0.5276	1.6331

Specimen C Consolidation
Direct Shear Test

Stantec Consulting Ltd.

File Location

lab_123312651_dsh_bh08rc4.HSD

Last Consolidation Sequence

Reading Number	Time	Disp. (mm)	Settlement (mm)	Void Ratio
0.0	00:00:00	0.5702	0.0000	0.7455
1.0	00:00:01	0.5706	-0.0005	0.7150
2.0	00:00:02	0.5501	0.0201	0.6792
3.0	00:00:03	0.5254	0.0448	0.6362
4.0	00:00:04	0.5247	0.0454	0.6351
5.0	00:00:05	0.5234	0.0468	0.6327
6.0	00:00:06	0.5228	0.0474	0.6316
7.0	00:00:12	0.5213	0.0489	0.6290
8.0	00:00:15	0.5209	0.0492	0.6285
9.0	00:00:30	0.5198	0.0504	0.6264
10.0	00:01:00	0.5186	0.0516	0.6244
11.0	00:02:00	0.5172	0.0529	0.6220
12.0	00:04:00	0.5158	0.0543	0.6196
13.0	00:08:00	0.5143	0.0559	0.6168
14.0	00:15:01	0.5130	0.0572	0.6146
15.0	00:30:02	0.5117	0.0585	0.6123
16.0	01:00:05	0.5108	0.0594	0.6108
17.0	02:00:10	0.5102	0.0600	0.6097
18.0	04:00:19	0.5098	0.0604	0.6090
19.0	08:00:39	0.5095	0.0606	0.6086
20.0	19:44:40	0.5095	0.0606	0.6086

Specimen A Consolidation Graphs

Consolidation Graph (Square Root Time)

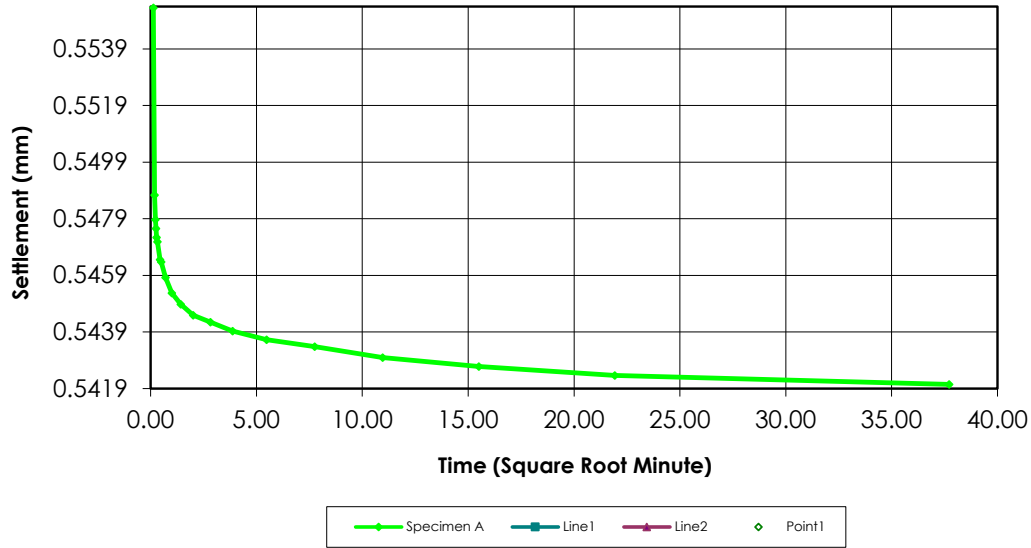

Consolidation Graph (Logarithmic Time)

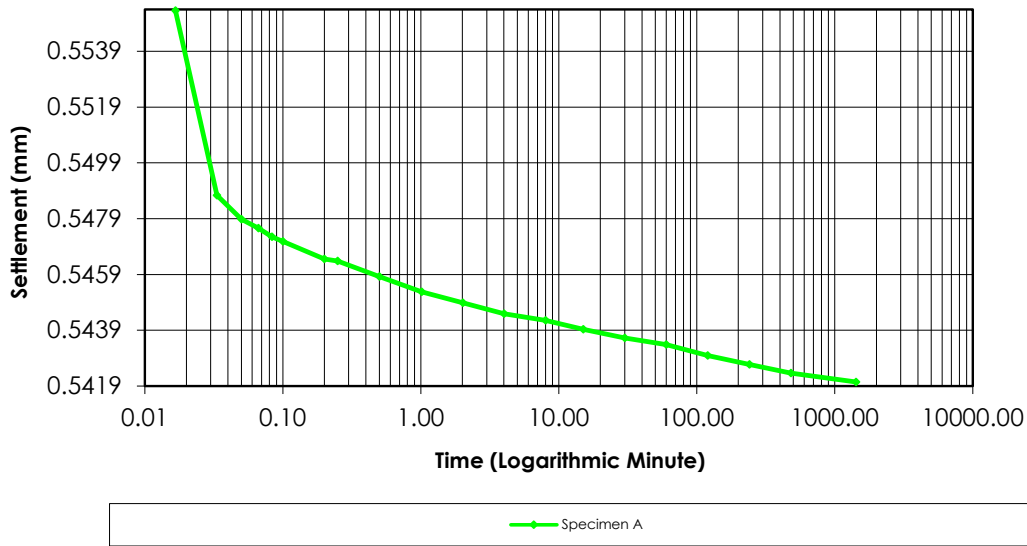

Specimen B Consolidation Graphs

Consolidation Graph (Square Root Time)

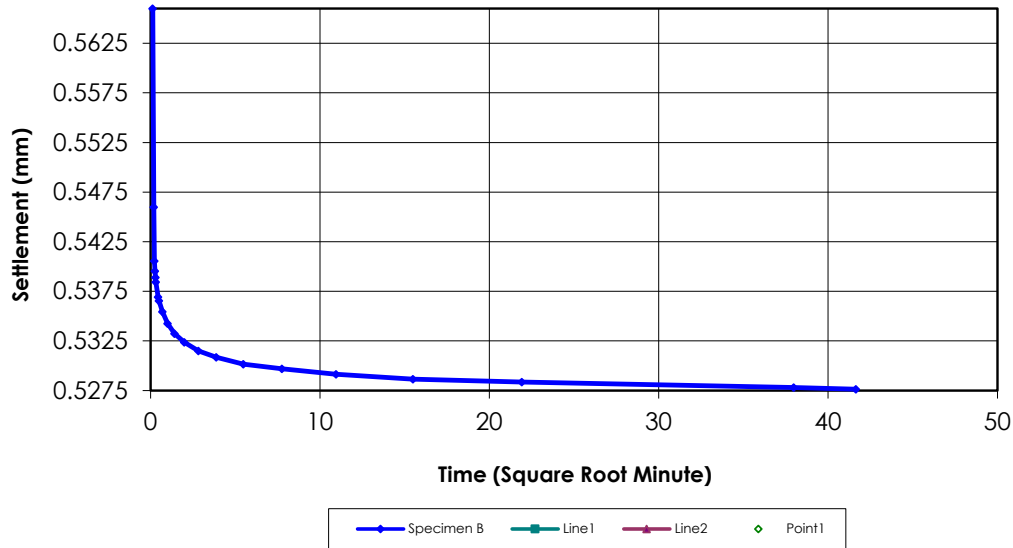

Consolidation Graph (Logarithmic Time)

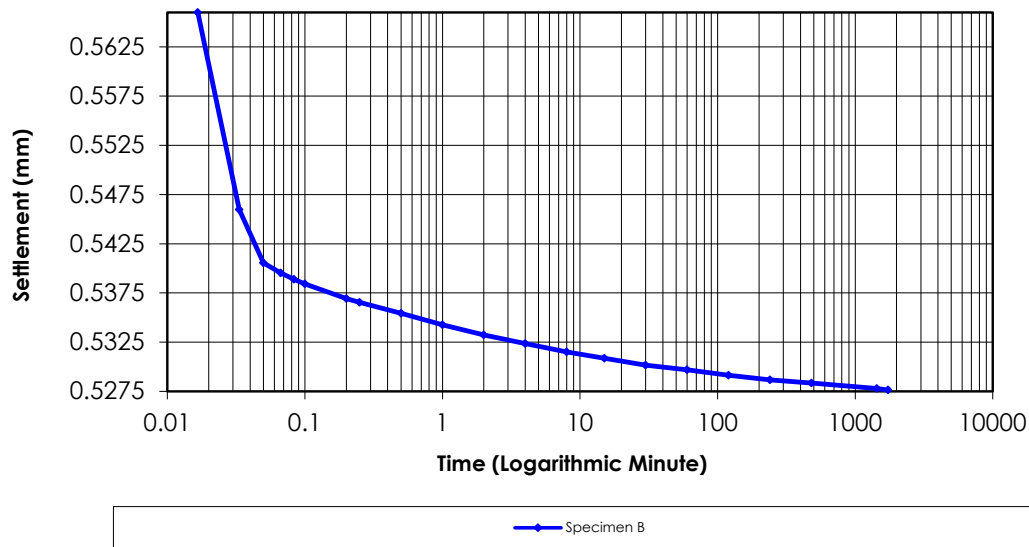

Specimen C Consolidation Graphs

Consolidation Graph (Square Root Time)

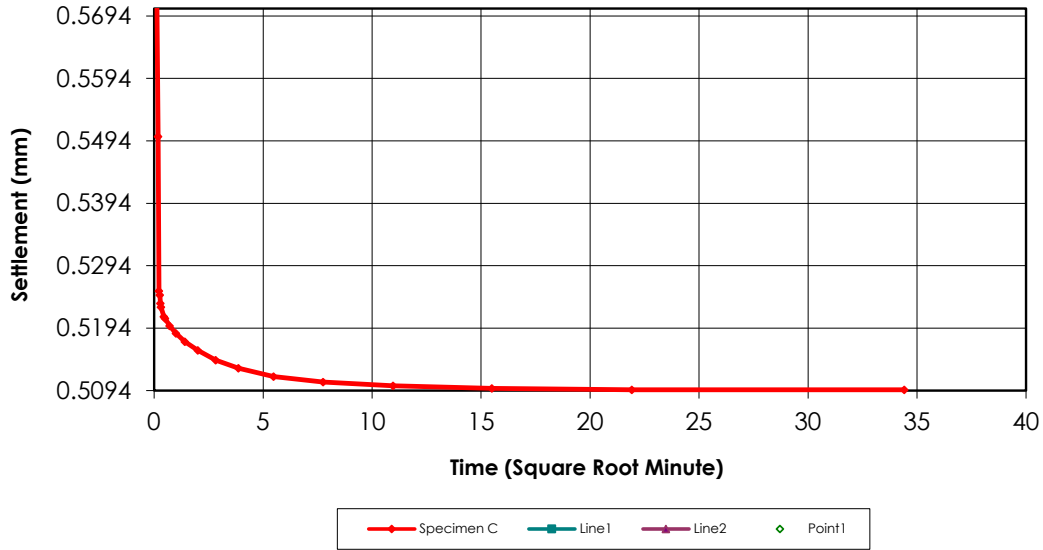

Consolidation Graph (Logarithmic Time)

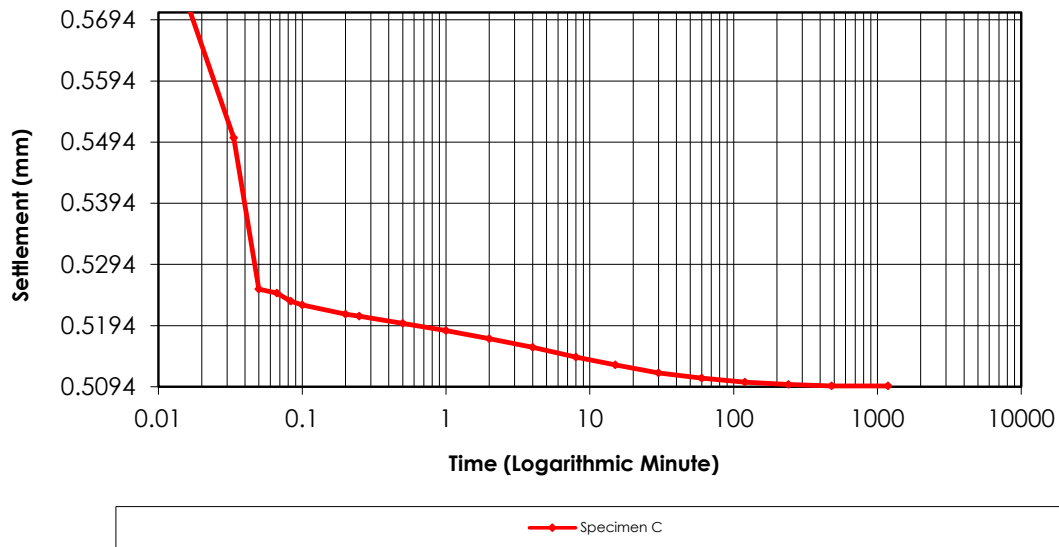

Specimen A All Shear Pass Data

Stantec Consulting Ltd.

Direct Shear Test

File Location

lab_123312651_dsh_bh08rc4.HSD

PASS 1

Reading Number	Time	Shear Force Kn	Horizontal Deformatio (mm)	Vertical Deformatio (mm)	Shear Force Kn	Horizontal Deformation (mm)	Vertical Deformation (mm)	Axial Strain (%)	Stress (kPa)
0	00:00:00	0.0	1.916	13.7540	0.0	0.000	0.0000	0.000	0.000
1	00:22:19	0.0	2.016	13.7420	0.0	0.100	-0.0120	0.167	2.262
2	00:36:01	0.0	2.118	13.7360	0.0	0.202	-0.0180	0.337	6.787
3	00:49:26	0.0	2.222	13.7320	0.0	0.306	-0.0220	0.511	13.575
4	01:03:03	0.1	2.324	13.7260	0.1	0.408	-0.0280	0.681	24.887
5	01:16:30	0.1	2.424	13.7180	0.1	0.508	-0.0360	0.848	29.412
6	01:29:27	0.1	2.524	13.7080	0.1	0.608	-0.0460	1.015	36.199
7	01:42:44	0.1	2.626	13.7000	0.1	0.710	-0.0540	1.185	38.462
8	01:55:39	0.1	2.726	13.6920	0.1	0.810	-0.0620	1.352	42.987
9	02:08:20	0.1	2.826	13.6840	0.1	0.910	-0.0700	1.519	45.249
10	02:20:45	0.1	2.926	13.6800	0.1	1.010	-0.0740	1.686	45.249
11	02:34:06	0.1	3.030	13.6740	0.1	1.114	-0.0800	1.860	47.512
12	02:47:03	0.1	3.130	13.6700	0.1	1.214	-0.0840	2.027	47.512
13	03:00:05	0.1	3.232	13.6660	0.1	1.316	-0.0880	2.197	47.512
14	03:13:13	0.1	3.334	13.6620	0.1	1.418	-0.0920	2.367	47.512
15	03:25:30	0.1	3.434	13.6600	0.1	1.518	-0.0940	2.534	47.512
16	03:38:20	0.1	3.534	13.6560	0.1	1.618	-0.0980	2.701	47.512
17	03:50:51	0.1	3.634	13.6520	0.1	1.718	-0.1020	2.868	49.774
18	04:03:46	0.1	3.736	13.6480	0.1	1.820	-0.1060	3.038	49.774
19	04:17:07	0.1	3.840	13.6460	0.1	1.924	-0.1080	3.212	49.774
20	04:30:08	0.1	3.942	13.6440	0.1	2.026	-0.1100	3.382	49.774
21	04:42:58	0.1	4.042	13.6440	0.1	2.126	-0.1100	3.549	49.774
22	04:55:24	0.1	4.142	13.6420	0.1	2.226	-0.1120	3.716	49.774
23	05:08:05	0.1	4.244	13.6380	0.1	2.328	-0.1160	3.886	49.774
24	05:21:01	0.1	4.344	13.6380	0.1	2.428	-0.1160	4.053	49.774
25	05:33:43	0.1	4.444	13.6360	0.1	2.528	-0.1180	4.220	49.774
26	05:46:04	0.1	4.544	13.6360	0.1	2.628	-0.1180	4.387	49.774
27	05:58:54	0.1	4.644	13.6340	0.1	2.728	-0.1200	4.554	49.774
28	06:11:37	0.1	4.746	13.6340	0.1	2.830	-0.1200	4.725	49.774
29	06:23:56	0.1	4.846	13.6320	0.1	2.930	-0.1220	4.891	49.774
30	06:36:25	0.1	4.946	13.6320	0.1	3.030	-0.1220	5.058	49.774
31	06:48:47	0.1	5.046	13.6320	0.1	3.130	-0.1220	5.225	49.774
32	07:01:18	0.1	5.146	13.6280	0.1	3.230	-0.1260	5.392	49.774
33	07:13:51	0.1	5.246	13.6280	0.1	3.330	-0.1260	5.559	49.774
34	07:26:06	0.1	5.346	13.6280	0.1	3.430	-0.1260	5.726	49.774
35	07:38:44	0.1	5.448	13.6280	0.1	3.532	-0.1260	5.896	49.774
36	07:51:15	0.1	5.548	13.6280	0.1	3.632	-0.1260	6.063	49.774
37	08:03:21	0.1	5.648	13.6280	0.1	3.732	-0.1260	6.230	49.774
38	08:15:25	0.1	5.748	13.6280	0.1	3.832	-0.1260	6.397	49.774
39	08:28:04	0.1	5.848	13.6280	0.1	3.932	-0.1260	6.564	49.774
40	08:40:47	0.1	5.950	13.6280	0.1	4.034	-0.1260	6.735	49.774
41	08:53:01	0.1	6.050	13.6280	0.1	4.134	-0.1260	6.902	49.774
42	09:05:34	0.1	6.150	13.6280	0.1	4.234	-0.1260	7.068	49.774
43	09:17:45	0.1	6.250	13.6280	0.1	4.334	-0.1260	7.235	49.774
44	09:29:50	0.1	6.350	13.6280	0.1	4.434	-0.1260	7.402	49.774
45	09:42:17	0.1	6.450	13.6280	0.1	4.534	-0.1260	7.569	49.774
46	09:54:34	0.1	6.550	13.6280	0.1	4.634	-0.1260	7.736	49.774

47	10:07:22	0.1	6.652	13.6280	0.1	4.736	-0.1260	7.907	49.774
48	10:20:14	0.1	6.752	13.6280	0.1	4.836	-0.1260	8.073	49.774
49	10:32:54	0.1	6.852	13.6280	0.1	4.936	-0.1260	8.240	49.774
50	10:45:42	0.1	6.954	13.6280	0.1	5.038	-0.1260	8.411	49.774
51	10:58:20	0.1	7.056	13.6280	0.1	5.140	-0.1260	8.581	49.774
52	11:10:56	0.1	7.156	13.6320	0.1	5.240	-0.1220	8.748	49.774
53	11:23:20	0.1	7.256	13.6320	0.1	5.340	-0.1220	8.915	49.774
54	11:36:03	0.1	7.358	13.6320	0.1	5.442	-0.1220	9.085	49.774
55	11:48:47	0.1	7.458	13.6340	0.1	5.542	-0.1200	9.252	49.774
56	12:01:27	0.1	7.560	13.6340	0.1	5.644	-0.1200	9.422	49.774
57	12:13:48	0.1	7.660	13.6340	0.1	5.744	-0.1200	9.589	49.774
58	12:26:25	0.1	7.762	13.6360	0.1	5.846	-0.1180	9.760	49.774
59	12:39:09	0.1	7.862	13.6360	0.1	5.946	-0.1180	9.927	49.774
60	12:51:30	0.1	7.962	13.6380	0.1	6.046	-0.1160	10.093	49.774
61	13:04:12	0.1	8.064	13.6380	0.1	6.148	-0.1160	10.264	49.774
62	13:17:09	0.1	8.166	13.6420	0.1	6.250	-0.1120	10.434	49.774
63	13:29:58	0.1	8.266	13.6420	0.1	6.350	-0.1120	10.601	49.774
64	13:42:46	0.1	8.366	13.6420	0.1	6.450	-0.1120	10.768	49.774
65	13:55:39	0.1	8.468	13.6440	0.1	6.552	-0.1100	10.938	49.774
66	14:08:35	0.1	8.568	13.6440	0.1	6.652	-0.1100	11.105	49.774
67	14:21:10	0.1	8.668	13.6440	0.1	6.752	-0.1100	11.272	49.774
68	14:33:36	0.1	8.768	13.6440	0.1	6.852	-0.1100	11.439	49.774
69	14:46:24	0.1	8.868	13.6440	0.1	6.952	-0.1100	11.606	47.512
70	14:59:03	0.1	8.968	13.6440	0.1	7.052	-0.1100	11.773	47.512
71	15:11:56	0.1	9.070	13.6440	0.1	7.154	-0.1100	11.943	47.512
72	15:24:49	0.1	9.170	13.6460	0.1	7.254	-0.1080	12.110	47.512
73	15:37:20	0.1	9.270	13.6460	0.1	7.354	-0.1080	12.277	47.512
74	15:49:58	0.1	9.370	13.6460	0.1	7.454	-0.1080	12.444	47.512
75	16:02:50	0.1	9.470	13.6460	0.1	7.554	-0.1080	12.611	47.512
76	16:14:58	0.1	9.570	13.6460	0.1	7.654	-0.1080	12.778	47.512
77	16:27:45	0.1	9.672	13.6460	0.1	7.756	-0.1080	12.948	47.512
78	16:40:24	0.1	9.772	13.6480	0.1	7.856	-0.1060	13.115	47.512
79	16:52:44	0.1	9.872	13.6480	0.1	7.956	-0.1060	13.282	47.512
80	17:05:09	0.1	9.972	13.6480	0.1	8.056	-0.1060	13.449	47.512
81	17:17:52	0.1	10.072	13.6480	0.1	8.156	-0.1060	13.616	47.512
82	17:30:19	0.1	10.172	13.6520	0.1	8.256	-0.1020	13.783	47.512
83	17:42:57	0.1	10.274	13.6520	0.1	8.358	-0.1020	13.953	47.512
84	17:55:43	0.1	10.374	13.6520	0.1	8.458	-0.1020	14.120	47.512
85	18:07:53	0.1	10.474	13.6520	0.1	8.558	-0.1020	14.287	45.249
86	18:20:18	0.1	10.574	13.6540	0.1	8.658	-0.1000	14.454	45.249
87	18:33:04	0.1	10.674	13.6540	0.1	8.758	-0.1000	14.621	45.249
88	18:45:34	0.1	10.774	13.6540	0.1	8.858	-0.1000	14.788	45.249
89	18:58:07	0.1	10.876	13.6540	0.1	8.960	-0.1000	14.958	45.249
90	19:10:39	0.1	10.976	13.6560	0.1	9.060	-0.0980	15.125	45.249
91	19:23:03	0.1	11.076	13.6560	0.1	9.160	-0.0980	15.292	45.249
92	19:35:11	0.1	11.176	13.6560	0.1	9.260	-0.0980	15.459	45.249
93	19:47:37	0.1	11.276	13.6560	0.1	9.360	-0.0980	15.626	45.249
94	19:59:38	0.1	11.376	13.6560	0.1	9.460	-0.0980	15.793	45.249
95	20:12:08	0.1	11.478	13.6600	0.1	9.562	-0.0940	15.963	45.249
96	20:24:37	0.1	11.578	13.6600	0.1	9.662	-0.0940	16.130	45.249
97	20:36:55	0.1	11.678	13.6600	0.1	9.762	-0.0940	16.297	45.249
98	20:49:40	0.1	11.780	13.6600	0.1	9.864	-0.0940	16.467	45.249
99	21:02:35	0.1	11.882	13.6600	0.1	9.966	-0.0940	16.638	45.249
100	21:15:17	0.1	11.982	13.6600	0.1	10.066	-0.0940	16.805	45.249
101	21:27:44	0.1	12.082	13.6620	0.1	10.166	-0.0920	16.972	45.249
102	21:40:31	0.1	12.184	13.6620	0.1	10.268	-0.0920	17.142	45.249
103	21:53:04	0.1	12.284	13.6620	0.1	10.368	-0.0920	17.309	45.249
104	22:05:13	0.1	12.384	13.6620	0.1	10.468	-0.0920	17.476	45.249
105	22:17:32	0.1	12.484	13.6620	0.1	10.568	-0.0920	17.643	45.249

106	22:30:16	0.1	12.584	13.6640	0.1	10.668	-0.0900	17.810	45.249
107	22:42:46	0.1	12.684	13.6640	0.1	10.768	-0.0900	17.977	45.249
108	22:55:34	0.1	12.786	13.6640	0.1	10.870	-0.0900	18.147	45.249
109	23:08:18	0.1	12.886	13.6640	0.1	10.970	-0.0900	18.314	42.987
110	23:20:45	0.1	12.986	13.6640	0.1	11.070	-0.0900	18.481	42.987
111	23:32:58	0.1	13.086	13.6640	0.1	11.170	-0.0900	18.648	42.987
112	23:45:43	0.1	13.186	13.6640	0.1	11.270	-0.0900	18.815	42.987
113	23:58:06	0.1	13.286	13.6640	0.1	11.370	-0.0900	18.982	42.987
114	24:10:58	0.1	13.388	13.6640	0.1	11.472	-0.0900	19.152	42.987
115	24:23:57	0.1	13.488	13.6640	0.1	11.572	-0.0900	19.319	42.987
116	24:36:36	0.1	13.588	13.6660	0.1	11.672	-0.0880	19.486	42.987
117	24:49:17	0.1	13.688	13.6660	0.1	11.772	-0.0880	19.653	42.987
118	25:02:17	0.1	13.788	13.6660	0.1	11.872	-0.0880	19.820	42.987
119	25:14:48	0.1	13.888	13.6660	0.1	11.972	-0.0880	19.987	42.987
120	25:16:06	0.1	13.898	13.6660	0.1	11.982	-0.0880	20.003	42.987

PASS 2

Reading Number	Time	Shear Force Kn	Horizontal Detormatio (mm)	verical Detormatio (mm)	Shear Force Kn	Horizontal Deformation (mm)	Vertical Deformation (mm)	Axial Strain (%)	Stress (kPa)
0	00:00:00	0.0	2.678	13.5100	0.0	0.000	0.0000	0.000	0.000
1	00:19:31	0.0	2.778	13.5020	0.0	0.100	-0.0080	0.167	6.787
2	00:32:45	0.0	2.880	13.4880	0.0	0.202	-0.0220	0.337	15.837
3	00:46:18	0.1	2.984	13.4760	0.1	0.306	-0.0340	0.511	22.625
4	00:59:31	0.1	3.086	13.4660	0.1	0.408	-0.0440	0.681	24.887
5	01:12:49	0.1	3.186	13.4620	0.1	0.508	-0.0480	0.848	27.150
6	01:25:57	0.1	3.288	13.4540	0.1	0.610	-0.0560	1.018	27.150
7	01:38:48	0.1	3.390	13.4480	0.1	0.712	-0.0620	1.189	27.150
8	01:51:50	0.1	3.492	13.4440	0.1	0.814	-0.0660	1.359	27.150
9	02:04:44	0.1	3.594	13.4400	0.1	0.916	-0.0700	1.529	27.150
10	02:17:34	0.1	3.694	13.4360	0.1	1.016	-0.0740	1.696	27.150
11	02:30:10	0.1	3.794	13.4340	0.1	1.116	-0.0760	1.863	27.150
12	02:43:02	0.1	3.896	13.4300	0.1	1.218	-0.0800	2.033	27.150
13	02:55:55	0.1	3.996	13.4260	0.1	1.318	-0.0840	2.200	27.150
14	03:08:35	0.1	4.096	13.4220	0.1	1.418	-0.0880	2.367	27.150
15	03:20:58	0.1	4.196	13.4220	0.1	1.518	-0.0880	2.534	27.150
16	03:33:58	0.1	4.296	13.4200	0.1	1.618	-0.0900	2.701	27.150
17	03:46:36	0.1	4.396	13.4200	0.1	1.718	-0.0900	2.868	27.150
18	03:59:37	0.1	4.498	13.4180	0.1	1.820	-0.0920	3.038	27.150
19	04:12:20	0.1	4.598	13.4160	0.1	1.920	-0.0940	3.205	27.150
20	04:24:54	0.1	4.700	13.4160	0.1	2.022	-0.0940	3.376	27.150
21	04:37:28	0.1	4.800	13.4120	0.1	2.122	-0.0980	3.543	27.150
22	04:50:02	0.1	4.902	13.4120	0.1	2.224	-0.0980	3.713	27.150
23	05:02:40	0.1	5.002	13.4100	0.1	2.324	-0.1000	3.880	27.150
24	05:15:02	0.1	5.102	13.4080	0.1	2.424	-0.1020	4.047	27.150
25	05:27:46	0.1	5.204	13.4080	0.1	2.526	-0.1020	4.217	27.150
26	05:40:22	0.1	5.306	13.4060	0.1	2.628	-0.1040	4.387	27.150
27	05:52:47	0.1	5.406	13.4060	0.1	2.728	-0.1040	4.554	27.150
28	06:04:52	0.1	5.506	13.4020	0.1	2.828	-0.1080	4.721	27.150
29	06:17:36	0.1	5.608	13.4020	0.1	2.930	-0.1080	4.891	27.150
30	06:30:20	0.1	5.708	13.4020	0.1	3.030	-0.1080	5.058	27.150
31	06:42:28	0.1	5.808	13.4020	0.1	3.130	-0.1080	5.225	27.150
32	06:55:11	0.1	5.910	13.4020	0.1	3.232	-0.1080	5.396	27.150
33	07:07:53	0.1	6.012	13.4020	0.1	3.334	-0.1080	5.566	27.150
34	07:20:30	0.1	6.116	13.4000	0.1	3.438	-0.1100	5.740	27.150
35	07:32:50	0.1	6.216	13.4000	0.1	3.538	-0.1100	5.907	27.150
36	07:45:19	0.1	6.318	13.4000	0.1	3.640	-0.1100	6.077	27.150

37	07:57:27	0.1	6.418	13.4000	0.1	3.740	-0.1100	6.244	27.150
38	08:10:07	0.1	6.520	13.4000	0.1	3.842	-0.1100	6.414	27.150
39	08:22:44	0.1	6.620	13.4000	0.1	3.942	-0.1100	6.581	27.150
40	08:35:24	0.1	6.720	13.4000	0.1	4.042	-0.1100	6.748	27.150
41	08:48:05	0.1	6.822	13.4000	0.1	4.144	-0.1100	6.918	27.150
42	09:00:42	0.1	6.924	13.4000	0.1	4.246	-0.1100	7.088	27.150
43	09:13:25	0.1	7.024	13.4000	0.1	4.346	-0.1100	7.255	27.150
44	09:25:48	0.1	7.124	13.4000	0.1	4.446	-0.1100	7.422	27.150
45	09:38:28	0.1	7.226	13.4000	0.1	4.548	-0.1100	7.593	27.150
46	09:51:07	0.1	7.326	13.4000	0.1	4.648	-0.1100	7.760	27.150
47	10:03:33	0.1	7.426	13.4000	0.1	4.748	-0.1100	7.927	27.150
48	10:16:22	0.1	7.528	13.4000	0.1	4.850	-0.1100	8.097	27.150
49	10:28:55	0.1	7.630	13.4000	0.1	4.952	-0.1100	8.267	27.150
50	10:41:41	0.1	7.730	13.4000	0.1	5.052	-0.1100	8.434	27.150
51	10:54:08	0.1	7.830	13.4000	0.1	5.152	-0.1100	8.601	27.150
52	11:06:48	0.1	7.932	13.4000	0.1	5.254	-0.1100	8.771	27.150
53	11:19:37	0.1	8.034	13.4000	0.1	5.356	-0.1100	8.942	27.150
54	11:32:22	0.1	8.134	13.4000	0.1	5.456	-0.1100	9.109	27.150
55	11:45:02	0.1	8.234	13.4000	0.1	5.556	-0.1100	9.275	27.150
56	11:57:56	0.1	8.336	13.4000	0.1	5.658	-0.1100	9.446	27.150
57	12:10:54	0.1	8.436	13.4000	0.1	5.758	-0.1100	9.613	27.150
58	12:23:39	0.1	8.536	13.4000	0.1	5.858	-0.1100	9.780	27.150
59	12:35:52	0.1	8.636	13.4000	0.1	5.958	-0.1100	9.947	27.150
60	12:48:58	0.1	8.736	13.4000	0.1	6.058	-0.1100	10.114	27.150
61	13:01:21	0.1	8.836	13.4000	0.1	6.158	-0.1100	10.280	27.150
62	13:14:13	0.1	8.938	13.4000	0.1	6.260	-0.1100	10.451	27.150
63	13:27:06	0.1	9.038	13.4000	0.1	6.360	-0.1100	10.618	27.150
64	13:39:44	0.1	9.138	13.4000	0.1	6.460	-0.1100	10.785	27.150
65	13:52:35	0.1	9.240	13.4000	0.1	6.562	-0.1100	10.955	27.150
66	14:05:26	0.1	9.342	13.4000	0.1	6.664	-0.1100	11.125	27.150
67	14:18:20	0.1	9.442	13.4000	0.1	6.764	-0.1100	11.292	27.150
68	14:30:55	0.1	9.542	13.4000	0.1	6.864	-0.1100	11.459	27.150
69	14:43:33	0.1	9.644	13.4000	0.1	6.966	-0.1100	11.629	27.150
70	14:56:11	0.1	9.744	13.4000	0.1	7.066	-0.1100	11.796	27.150
71	15:08:35	0.1	9.844	13.4020	0.1	7.166	-0.1080	11.963	27.150
72	15:20:55	0.1	9.944	13.4020	0.1	7.266	-0.1080	12.130	27.150
73	15:33:45	0.1	10.044	13.4020	0.1	7.366	-0.1080	12.297	27.150
74	15:46:11	0.1	10.144	13.4020	0.1	7.466	-0.1080	12.464	27.150
75	15:58:58	0.1	10.246	13.4020	0.1	7.568	-0.1080	12.634	27.150
76	16:11:38	0.1	10.346	13.4020	0.1	7.668	-0.1080	12.801	27.150
77	16:24:01	0.1	10.446	13.4020	0.1	7.768	-0.1080	12.968	27.150
78	16:36:09	0.1	10.546	13.4060	0.1	7.868	-0.1040	13.135	27.150
79	16:48:48	0.1	10.646	13.4060	0.1	7.968	-0.1040	13.302	27.150
80	17:01:02	0.1	10.746	13.4060	0.1	8.068	-0.1040	13.469	27.150
81	17:13:44	0.1	10.848	13.4080	0.1	8.170	-0.1020	13.639	27.150
82	17:26:28	0.1	10.948	13.4080	0.1	8.270	-0.1020	13.806	27.150
83	17:38:51	0.1	11.048	13.4080	0.1	8.370	-0.1020	13.973	27.150
84	17:51:13	0.1	11.148	13.4100	0.1	8.470	-0.1000	14.140	27.150
85	18:03:36	0.1	11.248	13.4100	0.1	8.570	-0.1000	14.307	27.150
86	18:15:32	0.1	11.348	13.4100	0.1	8.670	-0.1000	14.474	27.150
87	18:28:03	0.1	11.450	13.4120	0.1	8.772	-0.0980	14.644	27.150
88	18:40:40	0.1	11.550	13.4120	0.1	8.872	-0.0980	14.811	27.150
89	18:53:01	0.1	11.650	13.4160	0.1	8.972	-0.0940	14.978	27.150
90	19:05:38	0.1	11.750	13.4160	0.1	9.072	-0.0940	15.145	27.150
91	19:18:24	0.1	11.850	13.4160	0.1	9.172	-0.0940	15.312	27.150
92	19:31:03	0.1	11.950	13.4180	0.1	9.272	-0.0920	15.479	27.150
93	19:43:34	0.1	12.052	13.4180	0.1	9.374	-0.0920	15.649	27.150
94	19:56:06	0.1	12.152	13.4200	0.1	9.474	-0.0900	15.816	27.150
95	20:08:17	0.1	12.252	13.4200	0.1	9.574	-0.0900	15.983	27.150

96	20:20:27	0.1	12.352	13.4200	0.1	9.674	-0.0900	16.150	27.150
97	20:33:17	0.1	12.452	13.4200	0.1	9.774	-0.0900	16.317	27.150
98	20:45:43	0.1	12.552	13.4220	0.1	9.874	-0.0880	16.484	27.150
99	20:58:32	0.1	12.654	13.4220	0.1	9.976	-0.0880	16.654	27.150
100	21:11:06	0.1	12.754	13.4220	0.1	10.076	-0.0880	16.821	27.150
101	21:18:22	0.1	12.810	13.4220	0.1	10.132	-0.0880	16.915	27.150

Specimen B All Shear Pass Data

Stantec Consulting Ltd.

Direct Shear Test

File Location

lab_123312651_dsh_bh08rc4.HSD

PASS 1

Reading Number	Time	Shear Force Kn	Horizontal Deformation (mm)	Vertical Deformation (mm)	Shear Force Kn	Horizontal Deformation (mm)	Vertical Deformation (mm)	Axial Strain (%)	Stress (kPa)
0	00:00:00	0.0	2.090	13.3980	0.0	0.000	0.0000	0.000	0.000
1	00:23:53	0.1	2.192	13.3800	0.1	0.102	-0.0180	0.170	27.150
2	00:37:43	0.1	2.292	13.3620	0.1	0.202	-0.0360	0.337	47.512
3	00:50:51	0.2	2.392	13.3440	0.2	0.302	-0.0540	0.504	61.086
4	01:04:15	0.2	2.494	13.3280	0.2	0.404	-0.0700	0.674	74.661
5	01:17:38	0.2	2.594	13.3140	0.2	0.504	-0.0840	0.841	88.236
6	01:30:50	0.3	2.694	13.2980	0.3	0.604	-0.1000	1.008	97.286
7	01:43:41	0.3	2.794	13.2840	0.3	0.704	-0.1140	1.175	108.598
8	01:56:40	0.3	2.894	13.2700	0.3	0.804	-0.1280	1.342	113.123
9	02:09:53	0.3	2.996	13.2580	0.3	0.906	-0.1400	1.513	122.173
10	02:22:56	0.4	3.098	13.2460	0.4	1.008	-0.1520	1.683	124.435
11	02:36:00	0.4	3.200	13.2340	0.4	1.110	-0.1640	1.853	131.223
12	02:49:09	0.4	3.302	13.2240	0.4	1.212	-0.1740	2.023	133.485
13	03:02:26	0.4	3.406	13.2180	0.4	1.316	-0.1800	2.197	135.748
14	03:15:48	0.4	3.510	13.2100	0.4	1.420	-0.1880	2.371	135.748
15	03:28:42	0.4	3.610	13.2020	0.4	1.520	-0.1960	2.538	140.273
16	03:41:38	0.4	3.712	13.1960	0.4	1.622	-0.2020	2.708	140.273
17	03:54:14	0.4	3.812	13.1920	0.4	1.722	-0.2060	2.875	140.273
18	04:07:13	0.4	3.914	13.1840	0.4	1.824	-0.2140	3.045	140.273
19	04:20:20	0.4	4.014	13.1800	0.4	1.924	-0.2180	3.212	140.273
20	04:33:00	0.4	4.114	13.1760	0.4	2.024	-0.2220	3.379	140.273
21	04:45:58	0.4	4.216	13.1720	0.4	2.126	-0.2260	3.549	140.273
22	04:58:48	0.4	4.318	13.1660	0.4	2.228	-0.2320	3.720	140.273
23	05:11:35	0.4	4.418	13.1620	0.4	2.328	-0.2360	3.886	140.273
24	05:23:49	0.4	4.518	13.1580	0.4	2.428	-0.2400	4.053	140.273
25	05:36:38	0.4	4.620	13.1560	0.4	2.530	-0.2420	4.224	140.273
26	05:49:20	0.4	4.720	13.1520	0.4	2.630	-0.2460	4.391	140.273
27	06:01:52	0.4	4.820	13.1480	0.4	2.730	-0.2500	4.558	140.273
28	06:14:38	0.4	4.922	13.1460	0.4	2.832	-0.2520	4.728	140.273
29	06:27:17	0.4	5.024	13.1400	0.4	2.934	-0.2580	4.898	140.273
30	06:40:08	0.4	5.124	13.1380	0.4	3.034	-0.2600	5.065	140.273
31	06:52:36	0.4	5.226	13.1360	0.4	3.136	-0.2620	5.235	140.273
32	07:04:48	0.4	5.326	13.1360	0.4	3.236	-0.2620	5.402	140.273
33	07:17:18	0.4	5.426	13.1300	0.4	3.336	-0.2680	5.569	140.273
34	07:29:48	0.4	5.528	13.1280	0.4	3.438	-0.2700	5.740	135.748
35	07:41:53	0.4	5.628	13.1260	0.4	3.538	-0.2720	5.907	135.748
36	07:54:30	0.4	5.730	13.1240	0.4	3.640	-0.2740	6.077	135.748
37	08:07:13	0.4	5.830	13.1200	0.4	3.740	-0.2780	6.244	133.485
38	08:19:26	0.4	5.930	13.1180	0.4	3.840	-0.2800	6.411	133.485
39	08:31:50	0.4	6.032	13.1160	0.4	3.942	-0.2820	6.581	133.485
40	08:44:23	0.4	6.134	13.1160	0.4	4.044	-0.2820	6.751	133.485
41	08:56:51	0.4	6.234	13.1140	0.4	4.144	-0.2840	6.918	133.485
42	09:09:09	0.4	6.334	13.1100	0.4	4.244	-0.2880	7.085	133.485
43	09:21:38	0.4	6.436	13.1080	0.4	4.346	-0.2900	7.255	131.223
44	09:34:09	0.4	6.536	13.1060	0.4	4.446	-0.2920	7.422	131.223
45	09:46:40	0.4	6.636	13.1060	0.4	4.546	-0.2920	7.589	131.223
46	09:58:51	0.4	6.736	13.1020	0.4	4.646	-0.2960	7.756	131.223

47	10:11:27	0.4	6.836	13.1000	0.4	4.746	-0.2980	7.923	131.223
48	10:23:41	0.4	6.936	13.0980	0.4	4.846	-0.3000	8.090	131.223
49	10:36:16	0.4	7.038	13.0980	0.4	4.948	-0.3000	8.260	128.960
50	10:48:54	0.4	7.138	13.0960	0.4	5.048	-0.3020	8.427	128.960
51	11:01:16	0.4	7.238	13.0920	0.4	5.148	-0.3060	8.594	124.435
52	11:13:47	0.4	7.338	13.0920	0.4	5.248	-0.3060	8.761	124.435
53	11:26:27	0.4	7.438	13.0900	0.4	5.348	-0.3080	8.928	124.435
54	11:39:05	0.3	7.540	13.0880	0.3	5.450	-0.3100	9.098	122.173
55	11:51:18	0.3	7.640	13.0860	0.3	5.550	-0.3120	9.265	122.173
56	12:04:02	0.3	7.740	13.0860	0.3	5.650	-0.3120	9.432	122.173
57	12:16:14	0.3	7.840	13.0820	0.3	5.750	-0.3160	9.599	122.173
58	12:28:54	0.3	7.942	13.0800	0.3	5.852	-0.3180	9.770	122.173
59	12:41:45	0.3	8.044	13.0780	0.3	5.954	-0.3200	9.940	122.173
60	12:54:35	0.3	8.144	13.0780	0.3	6.054	-0.3200	10.107	122.173
61	13:07:08	0.3	8.244	13.0740	0.3	6.154	-0.3240	10.274	119.910
62	13:20:06	0.3	8.346	13.0740	0.3	6.256	-0.3240	10.444	119.910
63	13:33:05	0.3	8.448	13.0720	0.3	6.358	-0.3260	10.614	119.910
64	13:45:55	0.3	8.548	13.0720	0.3	6.458	-0.3260	10.781	119.910
65	13:58:35	0.3	8.648	13.0700	0.3	6.558	-0.3280	10.948	119.910
66	14:11:24	0.3	8.750	13.0680	0.3	6.660	-0.3300	11.119	117.648
67	14:24:12	0.3	8.850	13.0680	0.3	6.760	-0.3300	11.285	117.648
68	14:36:36	0.3	8.950	13.0640	0.3	6.860	-0.3340	11.452	117.648
69	14:49:19	0.3	9.050	13.0620	0.3	6.960	-0.3360	11.619	117.648
70	15:02:15	0.3	9.150	13.0600	0.3	7.060	-0.3380	11.786	113.123
71	15:14:54	0.3	9.250	13.0600	0.3	7.160	-0.3380	11.953	113.123
72	15:27:46	0.3	9.352	13.0580	0.3	7.262	-0.3400	12.124	113.123
73	15:40:27	0.3	9.452	13.0580	0.3	7.362	-0.3400	12.290	113.123
74	15:52:54	0.3	9.552	13.0580	0.3	7.462	-0.3400	12.457	113.123
75	16:05:03	0.3	9.652	13.0540	0.3	7.562	-0.3440	12.624	110.861
76	16:17:41	0.3	9.752	13.0540	0.3	7.662	-0.3440	12.791	110.861
77	16:29:59	0.3	9.852	13.0540	0.3	7.762	-0.3440	12.958	110.861
78	16:42:35	0.3	9.954	13.0520	0.3	7.864	-0.3460	13.129	110.861
79	16:55:23	0.3	10.054	13.0520	0.3	7.964	-0.3460	13.295	108.598
80	17:07:48	0.3	10.154	13.0500	0.3	8.064	-0.3480	13.462	108.598
81	17:20:38	0.3	10.256	13.0500	0.3	8.166	-0.3480	13.633	108.598
82	17:33:17	0.3	10.358	13.0460	0.3	8.268	-0.3520	13.803	104.073
83	17:45:45	0.3	10.458	13.0460	0.3	8.368	-0.3520	13.970	104.073
84	17:58:09	0.3	10.558	13.0460	0.3	8.468	-0.3520	14.137	104.073
85	18:10:42	0.3	10.660	13.0440	0.3	8.570	-0.3540	14.307	104.073
86	18:23:22	0.3	10.760	13.0440	0.3	8.670	-0.3540	14.474	104.073
87	18:35:37	0.3	10.860	13.0420	0.3	8.770	-0.3560	14.641	101.811
88	18:48:01	0.3	10.960	13.0420	0.3	8.870	-0.3560	14.808	101.811
89	19:00:40	0.3	11.060	13.0420	0.3	8.970	-0.3560	14.975	101.811
90	19:12:48	0.3	11.160	13.0400	0.3	9.070	-0.3580	15.142	101.811
91	19:25:19	0.3	11.262	13.0400	0.3	9.172	-0.3580	15.312	99.548
92	19:37:45	0.3	11.362	13.0360	0.3	9.272	-0.3620	15.479	99.548
93	19:49:59	0.3	11.462	13.0360	0.3	9.372	-0.3620	15.646	99.548
94	20:02:06	0.3	11.562	13.0360	0.3	9.472	-0.3620	15.813	99.548
95	20:14:40	0.3	11.662	13.0360	0.3	9.572	-0.3620	15.980	99.548
96	20:27:02	0.3	11.762	13.0360	0.3	9.672	-0.3620	16.147	99.548
97	20:39:35	0.3	11.864	13.0340	0.3	9.774	-0.3640	16.317	99.548
98	20:52:08	0.3	11.964	13.0340	0.3	9.874	-0.3640	16.484	99.548
99	21:04:29	0.3	12.064	13.0340	0.3	9.974	-0.3640	16.651	97.286
100	21:16:47	0.3	12.164	13.0340	0.3	10.074	-0.3640	16.818	97.286
101	21:29:34	0.3	12.264	13.0320	0.3	10.174	-0.3660	16.985	97.286
102	21:41:47	0.3	12.364	13.0320	0.3	10.274	-0.3660	17.152	97.286
103	21:54:36	0.3	12.466	13.0320	0.3	10.376	-0.3660	17.322	97.286
104	22:07:13	0.3	12.566	13.0300	0.3	10.476	-0.3680	17.489	97.286
105	22:19:33	0.3	12.666	13.0300	0.3	10.576	-0.3680	17.656	97.286

106	22:32:04	0.3	12.766	13.0300	0.3	10.676	-0.3680	17.823	92.761
107	22:44:40	0.3	12.866	13.0260	0.3	10.776	-0.3720	17.990	92.761
108	22:57:08	0.3	12.966	13.0260	0.3	10.876	-0.3720	18.157	92.761
109	23:09:46	0.3	13.068	13.0260	0.3	10.978	-0.3720	18.327	92.761
110	23:16:30	0.3	13.124	13.0260	0.3	11.034	-0.3720	18.421	92.761

PASS 2

Reading Number	Time	Shear Force (kN)	Horizontal Deformation (mm)	Vertical Deformation (mm)	Shear Force (kN)	Horizontal Deformation (mm)	Vertical Deformation (mm)	Axial Strain (%)	Stress (kPa)
0	00:00:00	0.0	2.188	12.9540	0.0	0.000	0.0000	0.000	0.000
1	00:22:20	0.1	2.288	12.9100	0.1	0.100	-0.0440	0.167	27.150
2	00:36:25	0.1	2.390	12.9000	0.1	0.202	-0.0540	0.337	49.774
3	00:50:00	0.2	2.490	12.8920	0.2	0.302	-0.0620	0.504	61.086
4	01:02:48	0.2	2.590	12.8840	0.2	0.402	-0.0700	0.671	67.874
5	01:15:50	0.2	2.692	12.8800	0.2	0.504	-0.0740	0.841	70.136
6	01:28:45	0.2	2.794	12.8740	0.2	0.606	-0.0800	1.012	70.136
7	01:41:41	0.2	2.894	12.8700	0.2	0.706	-0.0840	1.179	70.136
8	01:54:39	0.2	2.996	12.8640	0.2	0.808	-0.0900	1.349	70.136
9	02:07:35	0.2	3.098	12.8600	0.2	0.910	-0.0940	1.519	74.661
10	02:20:26	0.2	3.200	12.8560	0.2	1.012	-0.0980	1.689	74.661
11	02:33:20	0.2	3.302	12.8540	0.2	1.114	-0.1000	1.860	74.661
12	02:46:38	0.2	3.406	12.8520	0.2	1.218	-0.1020	2.033	74.661
13	02:59:56	0.2	3.510	12.8460	0.2	1.322	-0.1080	2.207	74.661
14	03:12:53	0.2	3.610	12.8440	0.2	1.422	-0.1100	2.374	74.661
15	03:25:42	0.2	3.712	12.8420	0.2	1.524	-0.1120	2.544	74.661
16	03:38:25	0.2	3.812	12.8360	0.2	1.624	-0.1180	2.711	74.661
17	03:51:17	0.2	3.914	12.8340	0.2	1.726	-0.1200	2.881	74.661
18	04:04:18	0.2	4.014	12.8320	0.2	1.826	-0.1220	3.048	74.661
19	04:17:01	0.2	4.114	12.8320	0.2	1.926	-0.1220	3.215	74.661
20	04:29:58	0.2	4.216	12.8280	0.2	2.028	-0.1260	3.386	74.661
21	04:42:58	0.2	4.318	12.8260	0.2	2.130	-0.1280	3.556	74.661
22	04:55:38	0.2	4.418	12.8240	0.2	2.230	-0.1300	3.723	74.661
23	05:08:01	0.2	4.518	12.8200	0.2	2.330	-0.1340	3.890	74.661
24	05:20:51	0.2	4.620	12.8160	0.2	2.432	-0.1380	4.060	74.661
25	05:33:25	0.2	4.720	12.8140	0.2	2.532	-0.1400	4.227	74.661
26	05:46:05	0.2	4.820	12.8140	0.2	2.632	-0.1400	4.394	74.661
27	05:58:51	0.2	4.922	12.8100	0.2	2.734	-0.1440	4.564	74.661
28	06:11:31	0.2	5.024	12.8080	0.2	2.836	-0.1460	4.735	74.661
29	06:24:11	0.2	5.124	12.8060	0.2	2.936	-0.1480	4.902	74.661
30	06:36:48	0.2	5.226	12.8040	0.2	3.038	-0.1500	5.072	74.661
31	06:49:15	0.2	5.326	12.8040	0.2	3.138	-0.1500	5.239	74.661
32	07:01:38	0.2	5.426	12.8000	0.2	3.238	-0.1540	5.406	74.661
33	07:14:16	0.2	5.528	12.7980	0.2	3.340	-0.1560	5.576	74.661
34	07:26:27	0.2	5.628	12.7960	0.2	3.440	-0.1580	5.743	74.661
35	07:39:04	0.2	5.730	12.7960	0.2	3.542	-0.1580	5.913	74.661
36	07:51:49	0.2	5.830	12.7920	0.2	3.642	-0.1620	6.080	74.661
37	08:03:58	0.2	5.930	12.7920	0.2	3.742	-0.1620	6.247	74.661
38	08:16:45	0.2	6.032	12.7900	0.2	3.844	-0.1640	6.417	74.661
39	08:29:08	0.2	6.134	12.7900	0.2	3.946	-0.1640	6.588	74.661
40	08:41:35	0.2	6.234	12.7900	0.2	4.046	-0.1640	6.755	74.661
41	08:53:48	0.2	6.334	12.7880	0.2	4.146	-0.1660	6.922	74.661
42	09:06:15	0.2	6.436	12.7880	0.2	4.248	-0.1660	7.092	74.661
43	09:18:48	0.2	6.536	12.7860	0.2	4.348	-0.1680	7.259	74.661
44	09:31:13	0.2	6.636	12.7860	0.2	4.448	-0.1680	7.426	74.661
45	09:43:35	0.2	6.736	12.7820	0.2	4.548	-0.1720	7.593	74.661
46	09:56:21	0.2	6.836	12.7820	0.2	4.648	-0.1720	7.760	74.661

47	10:08:36	0.2	6.936	12.7800	0.2	4.748	-0.1740	7.927	74.661
48	10:21:17	0.2	7.038	12.7800	0.2	4.850	-0.1740	8.097	74.661
49	10:33:55	0.2	7.138	12.7780	0.2	4.950	-0.1760	8.264	74.661
50	10:46:26	0.2	7.238	12.7780	0.2	5.050	-0.1760	8.431	74.661
51	10:58:51	0.2	7.338	12.7780	0.2	5.150	-0.1760	8.598	74.661
52	11:11:24	0.2	7.438	12.7760	0.2	5.250	-0.1780	8.765	74.661
53	11:24:17	0.2	7.540	12.7760	0.2	5.352	-0.1780	8.935	74.661
54	11:36:25	0.2	7.640	12.7760	0.2	5.452	-0.1780	9.102	74.661
55	11:49:09	0.2	7.740	12.7720	0.2	5.552	-0.1820	9.269	74.661
56	12:01:24	0.2	7.840	12.7720	0.2	5.652	-0.1820	9.436	74.661
57	12:14:07	0.2	7.942	12.7720	0.2	5.754	-0.1820	9.606	74.661
58	12:26:54	0.2	8.044	12.7720	0.2	5.856	-0.1820	9.776	74.661
59	12:39:38	0.2	8.144	12.7720	0.2	5.956	-0.1820	9.943	74.661
60	12:52:26	0.2	8.244	12.7700	0.2	6.056	-0.1840	10.110	74.661
61	13:05:26	0.2	8.346	12.7700	0.2	6.158	-0.1840	10.280	74.661
62	13:18:12	0.2	8.448	12.7700	0.2	6.260	-0.1840	10.451	74.661
63	13:31:18	0.2	8.548	12.7700	0.2	6.360	-0.1840	10.618	70.136
64	13:43:54	0.2	8.648	12.7700	0.2	6.460	-0.1840	10.785	70.136
65	13:56:47	0.2	8.750	12.7680	0.2	6.562	-0.1860	10.955	70.136
66	14:09:39	0.2	8.850	12.7680	0.2	6.662	-0.1860	11.122	70.136
67	14:22:11	0.2	8.950	12.7680	0.2	6.762	-0.1860	11.289	70.136
68	14:34:56	0.2	9.050	12.7680	0.2	6.862	-0.1860	11.456	70.136
69	14:47:47	0.2	9.150	12.7660	0.2	6.962	-0.1880	11.623	70.136
70	15:00:29	0.2	9.250	12.7660	0.2	7.062	-0.1880	11.790	70.136
71	15:13:25	0.2	9.352	12.7660	0.2	7.164	-0.1880	11.960	70.136
72	15:26:09	0.2	9.452	12.7660	0.2	7.264	-0.1880	12.127	70.136
73	15:38:33	0.2	9.552	12.7660	0.2	7.364	-0.1880	12.294	70.136
74	15:50:40	0.2	9.652	12.7660	0.2	7.464	-0.1880	12.461	70.136
75	16:03:28	0.2	9.752	12.7620	0.2	7.564	-0.1920	12.628	70.136
76	16:15:40	0.2	9.852	12.7620	0.2	7.664	-0.1920	12.795	70.136
77	16:28:20	0.2	9.954	12.7620	0.2	7.766	-0.1920	12.965	70.136
78	16:41:09	0.2	10.054	12.7620	0.2	7.866	-0.1920	13.132	70.136
79	16:53:38	0.2	10.154	12.7620	0.2	7.966	-0.1920	13.299	70.136
80	17:06:17	0.2	10.256	12.7620	0.2	8.068	-0.1920	13.469	70.136
81	17:18:56	0.2	10.358	12.7620	0.2	8.170	-0.1920	13.639	70.136
82	17:31:38	0.2	10.458	12.7620	0.2	8.270	-0.1920	13.806	70.136
83	17:43:55	0.2	10.558	12.7620	0.2	8.370	-0.1920	13.973	70.136
84	17:56:24	0.2	10.660	12.7600	0.2	8.472	-0.1940	14.144	70.136
85	18:09:06	0.2	10.760	12.7600	0.2	8.572	-0.1940	14.311	70.136
86	18:21:28	0.2	10.860	12.7600	0.2	8.672	-0.1940	14.477	70.136
87	18:33:44	0.2	10.960	12.7600	0.2	8.772	-0.1940	14.644	70.136
88	18:46:17	0.2	11.060	12.7600	0.2	8.872	-0.1940	14.811	70.136
89	18:58:45	0.2	11.160	12.7600	0.2	8.972	-0.1940	14.978	70.136
90	19:11:15	0.2	11.262	12.7600	0.2	9.074	-0.1940	15.149	70.136
91	19:23:35	0.2	11.362	12.7600	0.2	9.174	-0.1940	15.316	70.136
92	19:35:47	0.2	11.462	12.7600	0.2	9.274	-0.1940	15.482	70.136
93	19:47:49	0.2	11.562	12.7600	0.2	9.374	-0.1940	15.649	70.136
94	20:00:30	0.2	11.662	12.7600	0.2	9.474	-0.1940	15.816	70.136
95	20:12:42	0.2	11.762	12.7600	0.2	9.574	-0.1940	15.983	70.136
96	20:25:25	0.2	11.864	12.7600	0.2	9.676	-0.1940	16.154	70.136
97	20:38:09	0.2	11.964	12.7600	0.2	9.776	-0.1940	16.321	70.136
98	20:50:23	0.2	12.064	12.7600	0.2	9.876	-0.1940	16.487	70.136
99	21:02:45	0.2	12.164	12.7600	0.2	9.976	-0.1940	16.654	70.136
100	21:15:18	0.2	12.264	12.7580	0.2	10.076	-0.1960	16.821	70.136
101	21:27:42	0.2	12.364	12.7580	0.2	10.176	-0.1960	16.988	70.136
102	21:40:23	0.2	12.466	12.7580	0.2	10.278	-0.1960	17.159	70.136
103	21:52:56	0.2	12.566	12.7580	0.2	10.378	-0.1960	17.326	70.136
104	22:05:19	0.2	12.666	12.7580	0.2	10.478	-0.1960	17.492	70.136
105	22:17:46	0.2	12.766	12.7580	0.2	10.578	-0.1960	17.659	70.136

106	22:30:18	0.2	12.866	12.7580	0.2	10.678	-0.1960	17.826	70.136
107	22:42:42	0.2	12.966	12.7580	0.2	10.778	-0.1960	17.993	70.136
108	22:55:20	0.2	13.068	12.7540	0.2	10.880	-0.2000	18.164	70.136
109	23:08:06	0.2	13.168	12.7540	0.2	10.980	-0.2000	18.331	70.136
110	23:20:25	0.2	13.268	12.7540	0.2	11.080	-0.2000	18.497	70.136
111	23:32:51	0.2	13.368	12.7540	0.2	11.180	-0.2000	18.664	70.136
112	23:45:06	0.2	13.462	12.7540	0.2	11.274	-0.2000	18.821	70.136

Specimen C All Shear Pass Data

Stantec Consulting Ltd.

Direct Shear Test

File Location

lab_123312651_dsh_bh08rc4.HSD

PASS 1

Reading Number	Time	Shear Force Kn	Horizontal Deformation (mm)	Vertical Deformation (mm)	Shear Force Kn	Horizontal Deformation (mm)	Vertical Deformation (mm)	Axial Strain (%)	Stress (kPa)
0	00:00:00	0.0	2.122	12.9320	0.0	0.000	0.0000	0.000	0.000
1	00:19:15	0.1	2.222	12.9260	0.1	0.100	-0.0060	0.167	42.844
2	00:33:31	0.2	2.324	12.9120	0.2	0.202	-0.0200	0.337	74.413
3	00:47:20	0.3	2.424	12.8980	0.3	0.302	-0.0340	0.503	96.962
4	01:00:45	0.3	2.524	12.8820	0.3	0.402	-0.0500	0.670	117.256
5	01:14:20	0.4	2.626	12.8660	0.4	0.504	-0.0660	0.840	135.296
6	01:27:36	0.4	2.726	12.8520	0.4	0.604	-0.0800	1.007	151.080
7	01:40:31	0.5	2.826	12.8340	0.5	0.704	-0.0980	1.173	164.610
8	01:53:00	0.5	2.926	12.8200	0.5	0.804	-0.1120	1.340	175.884
9	02:06:45	0.5	3.030	12.8060	0.5	0.908	-0.1260	1.513	187.159
10	02:19:51	0.6	3.130	12.7920	0.6	1.008	-0.1400	1.680	196.179
11	02:33:01	0.6	3.232	12.7820	0.6	1.110	-0.1500	1.850	207.453
12	02:46:05	0.6	3.334	12.7700	0.6	1.212	-0.1620	2.020	214.218
13	02:58:45	0.6	3.434	12.7620	0.6	1.312	-0.1700	2.187	223.238
14	03:11:44	0.6	3.534	12.7520	0.6	1.412	-0.1800	2.353	227.748
15	03:23:58	0.7	3.634	12.7440	0.7	1.512	-0.1880	2.520	230.003
16	03:36:51	0.7	3.736	12.7340	0.7	1.614	-0.1980	2.690	236.767
17	03:50:10	0.7	3.840	12.7260	0.7	1.718	-0.2060	2.863	236.767
18	04:03:14	0.7	3.942	12.7200	0.7	1.820	-0.2120	3.033	241.277
19	04:16:07	0.7	4.042	12.7120	0.7	1.920	-0.2200	3.200	241.277
20	04:28:33	0.7	4.142	12.7060	0.7	2.020	-0.2260	3.367	241.277
21	04:41:12	0.7	4.244	12.7000	0.7	2.122	-0.2320	3.537	241.277
22	04:53:39	0.7	4.344	12.6920	0.7	2.222	-0.2400	3.703	241.277
23	05:06:01	0.7	4.444	12.6860	0.7	2.322	-0.2460	3.870	241.277
24	05:18:21	0.7	4.544	12.6820	0.7	2.422	-0.2500	4.037	241.277
25	05:31:00	0.7	4.644	12.6760	0.7	2.522	-0.2560	4.203	241.277
26	05:43:31	0.7	4.746	12.6720	0.7	2.624	-0.2600	4.373	239.022
27	05:55:47	0.7	4.846	12.6660	0.7	2.724	-0.2660	4.540	239.022
28	06:08:32	0.7	4.946	12.6600	0.7	2.824	-0.2720	4.707	236.767
29	06:20:49	0.7	5.046	12.6580	0.7	2.924	-0.2740	4.873	236.767
30	06:33:05	0.7	5.146	12.6540	0.7	3.024	-0.2780	5.040	236.767
31	06:45:34	0.7	5.246	12.6500	0.7	3.124	-0.2820	5.207	234.512
32	06:57:47	0.7	5.346	12.6460	0.7	3.224	-0.2860	5.373	234.512
33	07:10:13	0.7	5.448	12.6440	0.7	3.326	-0.2880	5.543	234.512
34	07:22:37	0.7	5.548	12.6400	0.7	3.426	-0.2920	5.710	230.003
35	07:34:42	0.6	5.648	12.6360	0.6	3.526	-0.2960	5.877	227.748
36	07:46:52	0.6	5.748	12.6320	0.6	3.626	-0.3000	6.043	227.748
37	07:59:25	0.6	5.848	12.6300	0.6	3.726	-0.3020	6.210	225.493
38	08:12:03	0.6	5.950	12.6280	0.6	3.828	-0.3040	6.380	225.493
39	08:24:27	0.6	6.050	12.6260	0.6	3.928	-0.3060	6.547	223.238
40	08:37:02	0.6	6.150	12.6220	0.6	4.028	-0.3100	6.713	223.238
41	08:49:09	0.6	6.250	12.6200	0.6	4.128	-0.3120	6.880	223.238
42	09:01:20	0.6	6.350	12.6180	0.6	4.228	-0.3140	7.047	216.473
43	09:13:54	0.6	6.450	12.6160	0.6	4.328	-0.3160	7.213	216.473
44	09:26:08	0.6	6.550	12.6100	0.6	4.428	-0.3220	7.380	214.218
45	09:38:41	0.6	6.652	12.6100	0.6	4.530	-0.3220	7.550	214.218
46	09:51:13	0.6	6.752	12.6080	0.6	4.630	-0.3240	7.717	214.218

47	10:03:39	0.6	6.852	12.6060	0.6	4.730	-0.3260	7.883	214.218
48	10:16:07	0.6	6.954	12.6020	0.6	4.832	-0.3300	8.053	209.708
49	10:28:34	0.6	7.056	12.6000	0.6	4.934	-0.3320	8.223	209.708
50	10:41:08	0.6	7.156	12.5980	0.6	5.034	-0.3340	8.390	209.708
51	10:53:30	0.6	7.256	12.5940	0.6	5.134	-0.3380	8.557	207.453
52	11:06:08	0.6	7.358	12.5920	0.6	5.236	-0.3400	8.727	205.198
53	11:18:55	0.6	7.458	12.5900	0.6	5.336	-0.3420	8.893	202.943
54	11:31:34	0.6	7.560	12.5900	0.6	5.438	-0.3420	9.063	202.943
55	11:43:51	0.6	7.660	12.5880	0.6	5.538	-0.3440	9.230	202.943
56	11:56:29	0.6	7.762	12.5840	0.6	5.640	-0.3480	9.400	198.434
57	12:09:14	0.6	7.862	12.5820	0.6	5.740	-0.3500	9.567	198.434
58	12:21:27	0.6	7.962	12.5800	0.6	5.840	-0.3520	9.733	198.434
59	12:34:05	0.6	8.064	12.5800	0.6	5.942	-0.3520	9.903	196.179
60	12:46:49	0.5	8.166	12.5780	0.5	6.044	-0.3540	10.073	193.924
61	12:59:36	0.5	8.266	12.5720	0.5	6.144	-0.3600	10.240	193.924
62	13:12:22	0.5	8.366	12.5720	0.5	6.244	-0.3600	10.407	191.669
63	13:25:19	0.5	8.468	12.5700	0.5	6.346	-0.3620	10.577	191.669
64	13:38:08	0.5	8.568	12.5660	0.5	6.446	-0.3660	10.743	191.669
65	13:50:43	0.5	8.668	12.5660	0.5	6.546	-0.3660	10.910	187.159
66	14:03:07	0.5	8.768	12.5640	0.5	6.646	-0.3680	11.077	187.159
67	14:15:54	0.5	8.868	12.5620	0.5	6.746	-0.3700	11.243	184.904
68	14:28:27	0.5	8.968	12.5600	0.5	6.846	-0.3720	11.410	184.904
69	14:41:24	0.5	9.070	12.5600	0.5	6.948	-0.3720	11.580	184.904
70	14:54:27	0.5	9.170	12.5560	0.5	7.048	-0.3760	11.747	184.904
71	15:07:06	0.5	9.270	12.5540	0.5	7.148	-0.3780	11.913	184.904
72	15:19:45	0.5	9.370	12.5520	0.5	7.248	-0.3800	12.080	182.649
73	15:32:26	0.5	9.470	12.5500	0.5	7.348	-0.3820	12.247	180.394
74	15:44:25	0.5	9.570	12.5500	0.5	7.448	-0.3820	12.413	180.394
75	15:57:06	0.5	9.672	12.5460	0.5	7.550	-0.3860	12.583	180.394
76	16:09:45	0.5	9.772	12.5440	0.5	7.650	-0.3880	12.750	175.884
77	16:22:07	0.5	9.872	12.5420	0.5	7.750	-0.3900	12.917	175.884
78	16:34:32	0.5	9.972	12.5380	0.5	7.850	-0.3940	13.083	175.884
79	16:47:26	0.5	10.072	12.5380	0.5	7.950	-0.3940	13.250	175.884
80	16:59:52	0.5	10.172	12.5360	0.5	8.050	-0.3960	13.417	173.629
81	17:12:25	0.5	10.274	12.5340	0.5	8.152	-0.3980	13.587	171.374
82	17:25:05	0.5	10.374	12.5320	0.5	8.252	-0.4000	13.753	171.374
83	17:37:12	0.5	10.474	12.5280	0.5	8.352	-0.4040	13.920	171.374
84	17:49:28	0.5	10.574	12.5280	0.5	8.452	-0.4040	14.087	171.374
85	18:01:59	0.5	10.674	12.5260	0.5	8.552	-0.4060	14.253	166.865
86	18:14:22	0.5	10.774	12.5260	0.5	8.652	-0.4060	14.420	166.865
87	18:27:02	0.5	10.876	12.5240	0.5	8.754	-0.4080	14.590	166.865
88	18:39:44	0.5	10.976	12.5220	0.5	8.854	-0.4100	14.757	166.865
89	18:52:07	0.5	11.076	12.5180	0.5	8.954	-0.4140	14.923	164.610
90	19:04:13	0.5	11.176	12.5160	0.5	9.054	-0.4160	15.090	164.610
91	19:16:42	0.5	11.276	12.5160	0.5	9.154	-0.4160	15.257	164.610
92	19:28:47	0.5	11.376	12.5140	0.5	9.254	-0.4180	15.423	164.610
93	19:41:15	0.5	11.478	12.5120	0.5	9.356	-0.4200	15.593	162.355
94	19:53:56	0.5	11.578	12.5080	0.5	9.456	-0.4240	15.760	162.355
95	20:06:10	0.5	11.678	12.5080	0.5	9.556	-0.4240	15.927	160.100
96	20:18:50	0.5	11.780	12.5060	0.5	9.658	-0.4260	16.097	160.100
97	20:31:28	0.5	11.882	12.5060	0.5	9.760	-0.4260	16.267	160.100
98	20:44:04	0.5	11.982	12.5040	0.5	9.860	-0.4280	16.433	160.100
99	20:56:27	0.4	12.082	12.5000	0.4	9.960	-0.4320	16.600	155.590
100	21:08:58	0.4	12.184	12.4980	0.4	10.062	-0.4340	16.770	155.590
101	21:21:39	0.4	12.284	12.4980	0.4	10.162	-0.4340	16.937	155.590
102	21:33:59	0.4	12.384	12.4960	0.4	10.262	-0.4360	17.103	153.335
103	21:46:26	0.4	12.484	12.4940	0.4	10.362	-0.4380	17.270	153.335
104	21:59:07	0.4	12.584	12.4900	0.4	10.462	-0.4420	17.437	153.335
105	22:11:35	0.4	12.684	12.4900	0.4	10.562	-0.4420	17.603	153.335

106	22:24:22	0.4	12.786	12.4880	0.4	10.664	-0.4440	17.773	153.335
107	22:37:01	0.4	12.886	12.4880	0.4	10.764	-0.4440	17.940	153.335
108	22:49:31	0.4	12.986	12.4860	0.4	10.864	-0.4460	18.107	151.080
109	23:01:48	0.4	13.086	12.4860	0.4	10.964	-0.4460	18.273	148.825
110	23:14:31	0.4	13.186	12.4840	0.4	11.064	-0.4480	18.440	148.825
111	23:26:59	0.4	13.286	12.4840	0.4	11.164	-0.4480	18.607	148.825
112	23:39:51	0.4	13.388	12.4800	0.4	11.266	-0.4520	18.777	148.825
113	23:49:08	0.4	13.456	12.4800	0.4	11.334	-0.4520	18.890	148.825

PASS 2

Reading Number	Time	Shear Force Kn	Horizontal Deformatio (mm)	Vertical Deformatio (mm)	Shear Force Kn	Horizontal Deformation (mm)	Vertical Deformation (mm)	Axial Strain (%)	Stress (kPa)
0	00:00:00	0.0	2.524	12.4860	0.0	0.000	0.0000	0.000	0.000
1	00:19:38	0.1	2.626	12.4280	0.1	0.102	-0.0580	0.170	22.549
2	00:34:17	0.2	2.726	12.4120	0.2	0.202	-0.0740	0.337	54.118
3	00:47:58	0.2	2.826	12.4020	0.2	0.302	-0.0840	0.503	74.413
4	01:01:03	0.2	2.926	12.3940	0.2	0.402	-0.0920	0.670	87.942
5	01:14:55	0.3	3.030	12.3840	0.3	0.506	-0.1020	0.843	96.962
6	01:28:09	0.3	3.130	12.3760	0.3	0.606	-0.1100	1.010	99.217
7	01:41:20	0.3	3.232	12.3720	0.3	0.708	-0.1140	1.180	101.472
8	01:54:31	0.3	3.334	12.3660	0.3	0.810	-0.1200	1.350	103.727
9	02:06:51	0.3	3.434	12.3620	0.3	0.910	-0.1240	1.517	103.727
10	02:19:50	0.3	3.534	12.3580	0.3	1.010	-0.1280	1.683	103.727
11	02:32:18	0.3	3.634	12.3540	0.3	1.110	-0.1320	1.850	103.727
12	02:45:04	0.3	3.736	12.3480	0.3	1.212	-0.1380	2.020	108.236
13	02:58:21	0.3	3.840	12.3460	0.3	1.316	-0.1400	2.193	108.236
14	03:11:20	0.3	3.942	12.3440	0.3	1.418	-0.1420	2.363	108.236
15	03:24:21	0.3	4.042	12.3380	0.3	1.518	-0.1480	2.530	108.236
16	03:36:50	0.3	4.142	12.3360	0.3	1.618	-0.1500	2.697	110.491
17	03:49:49	0.3	4.244	12.3340	0.3	1.720	-0.1520	2.867	110.491
18	04:02:40	0.3	4.344	12.3300	0.3	1.820	-0.1560	3.033	110.491
19	04:15:16	0.3	4.444	12.3280	0.3	1.920	-0.1580	3.200	110.491
20	04:27:30	0.3	4.544	12.3260	0.3	2.020	-0.1600	3.367	110.491
21	04:40:17	0.3	4.644	12.3240	0.3	2.120	-0.1620	3.533	110.491
22	04:52:59	0.3	4.746	12.3240	0.3	2.222	-0.1620	3.703	110.491
23	05:05:22	0.3	4.846	12.3200	0.3	2.322	-0.1660	3.870	110.491
24	05:18:12	0.3	4.946	12.3180	0.3	2.422	-0.1680	4.037	110.491
25	05:30:34	0.3	5.046	12.3160	0.3	2.522	-0.1700	4.203	110.491
26	05:43:05	0.3	5.146	12.3120	0.3	2.622	-0.1740	4.370	110.491
27	05:55:33	0.3	5.246	12.3100	0.3	2.722	-0.1760	4.537	110.491
28	06:07:54	0.3	5.346	12.3080	0.3	2.822	-0.1780	4.703	110.491
29	06:20:29	0.3	5.448	12.3060	0.3	2.924	-0.1800	4.873	110.491
30	06:33:05	0.3	5.548	12.3060	0.3	3.024	-0.1800	5.040	110.491
31	06:45:10	0.3	5.648	12.3020	0.3	3.124	-0.1840	5.207	110.491
32	06:57:20	0.3	5.748	12.3020	0.3	3.224	-0.1840	5.373	110.491
33	07:09:59	0.3	5.848	12.3000	0.3	3.324	-0.1860	5.540	110.491
34	07:22:36	0.3	5.950	12.2980	0.3	3.426	-0.1880	5.710	110.491
35	07:34:51	0.3	6.050	12.2980	0.3	3.526	-0.1880	5.877	110.491
36	07:47:25	0.3	6.150	12.2960	0.3	3.626	-0.1900	6.043	110.491
37	07:59:35	0.3	6.250	12.2920	0.3	3.726	-0.1940	6.210	110.491
38	08:11:47	0.3	6.350	12.2920	0.3	3.826	-0.1940	6.377	110.491
39	08:24:09	0.3	6.450	12.2900	0.3	3.926	-0.1960	6.543	110.491
40	08:36:26	0.3	6.550	12.2880	0.3	4.026	-0.1980	6.710	110.491
41	08:49:04	0.3	6.652	12.2880	0.3	4.128	-0.1980	6.880	110.491
42	09:01:41	0.3	6.752	12.2840	0.3	4.228	-0.2020	7.047	110.491
43	09:14:08	0.3	6.852	12.2840	0.3	4.328	-0.2020	7.213	110.491

44	09:26:45	0.3	6.954	12.2840	0.3	4.430	-0.2020	7.383	110.491
45	09:39:24	0.3	7.056	12.2820	0.3	4.532	-0.2040	7.553	110.491
46	09:52:00	0.3	7.156	12.2820	0.3	4.632	-0.2040	7.720	110.491
47	10:04:18	0.3	7.256	12.2800	0.3	4.732	-0.2060	7.887	110.491
48	10:17:00	0.3	7.358	12.2800	0.3	4.834	-0.2060	8.057	110.491
49	10:29:42	0.3	7.458	12.2780	0.3	4.934	-0.2080	8.223	110.491
50	10:42:30	0.3	7.560	12.2780	0.3	5.036	-0.2080	8.393	110.491
51	10:54:50	0.3	7.660	12.2740	0.3	5.136	-0.2120	8.560	110.491
52	11:07:35	0.3	7.762	12.2740	0.3	5.238	-0.2120	8.730	110.491
53	11:20:17	0.3	7.862	12.2720	0.3	5.338	-0.2140	8.897	110.491
54	11:32:28	0.3	7.962	12.2720	0.3	5.438	-0.2140	9.063	110.491
55	11:45:14	0.3	8.064	12.2700	0.3	5.540	-0.2160	9.233	110.491
56	11:58:01	0.3	8.166	12.2700	0.3	5.642	-0.2160	9.403	110.491
57	12:10:56	0.3	8.266	12.2680	0.3	5.742	-0.2180	9.570	110.491
58	12:23:45	0.3	8.366	12.2680	0.3	5.842	-0.2180	9.737	110.491
59	12:36:46	0.3	8.468	12.2640	0.3	5.944	-0.2220	9.907	110.491
60	12:49:39	0.3	8.568	12.2640	0.3	6.044	-0.2220	10.073	110.491
61	13:02:10	0.3	8.668	12.2640	0.3	6.144	-0.2220	10.240	110.491
62	13:14:43	0.3	8.768	12.2620	0.3	6.244	-0.2240	10.407	110.491
63	13:27:30	0.3	8.868	12.2620	0.3	6.344	-0.2240	10.573	110.491
64	13:40:04	0.3	8.968	12.2620	0.3	6.444	-0.2240	10.740	110.491
65	13:53:03	0.3	9.070	12.2600	0.3	6.546	-0.2260	10.910	110.491
66	14:06:05	0.3	9.170	12.2600	0.3	6.646	-0.2260	11.077	110.491
67	14:18:47	0.3	9.270	12.2580	0.3	6.746	-0.2280	11.243	110.491
68	14:31:19	0.3	9.370	12.2580	0.3	6.846	-0.2280	11.410	108.236
69	14:44:02	0.3	9.470	12.2580	0.3	6.946	-0.2280	11.577	108.236
70	14:56:14	0.3	9.570	12.2540	0.3	7.046	-0.2320	11.743	108.236
71	15:08:52	0.3	9.672	12.2540	0.3	7.148	-0.2320	11.913	108.236
72	15:21:38	0.3	9.772	12.2540	0.3	7.248	-0.2320	12.080	108.236
73	15:34:00	0.3	9.872	12.2520	0.3	7.348	-0.2340	12.247	108.236
74	15:46:23	0.3	9.972	12.2520	0.3	7.448	-0.2340	12.413	108.236
75	15:59:13	0.3	10.072	12.2500	0.3	7.548	-0.2360	12.580	108.236
76	16:11:35	0.3	10.172	12.2500	0.3	7.648	-0.2360	12.747	108.236
77	16:24:15	0.3	10.274	12.2500	0.3	7.750	-0.2360	12.917	108.236
78	16:36:56	0.3	10.374	12.2460	0.3	7.850	-0.2400	13.083	108.236
79	16:49:10	0.3	10.474	12.2460	0.3	7.950	-0.2400	13.250	108.236
80	17:01:26	0.3	10.574	12.2440	0.3	8.050	-0.2420	13.417	108.236
81	17:14:00	0.3	10.674	12.2440	0.3	8.150	-0.2420	13.583	108.236
82	17:26:27	0.3	10.774	12.2440	0.3	8.250	-0.2420	13.750	108.236
83	17:38:59	0.3	10.876	12.2440	0.3	8.352	-0.2420	13.920	108.236
84	17:51:36	0.3	10.976	12.2420	0.3	8.452	-0.2440	14.087	108.236
85	18:04:01	0.3	11.076	12.2420	0.3	8.552	-0.2440	14.253	108.236
86	18:16:06	0.3	11.176	12.2420	0.3	8.652	-0.2440	14.420	108.236
87	18:28:40	0.3	11.276	12.2420	0.3	8.752	-0.2440	14.587	108.236
88	18:40:40	0.3	11.376	12.2400	0.3	8.852	-0.2460	14.753	108.236
89	18:53:13	0.3	11.478	12.2400	0.3	8.954	-0.2460	14.923	108.236
90	19:05:44	0.3	11.578	12.2400	0.3	9.054	-0.2460	15.090	108.236
91	19:18:06	0.3	11.678	12.2360	0.3	9.154	-0.2500	15.257	103.727
92	19:30:49	0.3	11.780	12.2360	0.3	9.256	-0.2500	15.427	103.727
93	19:43:31	0.3	11.882	12.2340	0.3	9.358	-0.2520	15.597	103.727
94	19:56:13	0.3	11.982	12.2340	0.3	9.458	-0.2520	15.763	103.727
95	20:08:39	0.3	12.082	12.2340	0.3	9.558	-0.2520	15.930	103.727
96	20:21:16	0.3	12.184	12.2320	0.3	9.660	-0.2540	16.100	103.727
97	20:33:55	0.3	12.284	12.2320	0.3	9.760	-0.2540	16.267	103.727
98	20:46:14	0.3	12.384	12.2300	0.3	9.860	-0.2560	16.433	103.727
99	20:58:44	0.3	12.484	12.2300	0.3	9.960	-0.2560	16.600	103.727
100	21:11:30	0.3	12.584	12.2300	0.3	10.060	-0.2560	16.767	103.727
101	21:24:01	0.3	12.684	12.2260	0.3	10.160	-0.2600	16.933	103.727
102	21:36:53	0.3	12.786	12.2260	0.3	10.262	-0.2600	17.103	103.727

103	21:49:33	0.3	12.886	12.2240	0.3	10.362	-0.2620	17.270	103.727
104	22:02:04	0.3	12.986	12.2240	0.3	10.462	-0.2620	17.437	103.727
105	22:14:14	0.3	13.086	12.2240	0.3	10.562	-0.2620	17.603	103.727
106	22:26:57	0.3	13.186	12.2240	0.3	10.662	-0.2620	17.770	103.727
107	22:39:27	0.3	13.286	12.2220	0.3	10.762	-0.2640	17.937	103.727
108	22:52:26	0.3	13.388	12.2220	0.3	10.864	-0.2640	18.107	103.727
109	23:05:32	0.3	13.488	12.2220	0.3	10.964	-0.2640	18.273	103.727
110	23:18:09	0.3	13.588	12.2180	0.3	11.064	-0.2680	18.440	103.727
111	23:30:43	0.3	13.688	12.2180	0.3	11.164	-0.2680	18.607	103.727
112	23:38:38	0.3	13.748	12.2180	0.3	11.224	-0.2680	18.707	103.727

GEOTECHNICAL INVESTIGATION REPORT

February 24, 2017

Appendix E Slope Stability Outputs



Name: Sheared Zone Model: Mohr-Coulomb Unit Weight: 20 kN/m³ Cohesion: 0 kPa Phi: 14 ° Piezometric Line: 1 B-bar: 0 Add Weight: No
 Name: Softened Bedrock Model: Undrained (Phi=0) Unit Weight: 21 kN/m³ Cohesion: 100 kPa Piezometric Line: 1 B-bar: 0 Add Weight: No
 Name: Competent Bedrock (Infinite Strength) Model: Bedrock (Impenetrable) Piezometric Line: 1 B-bar: 0 Add Weight: No
 Name: Upper Competent Bedrock Model: Undrained (Phi=0) Unit Weight: 21 kN/m³ Cohesion: 200 kPa Piezometric Line: 1 B-bar: 0 Add Weight: No
 Name: Disturbed Bedrock Model: Undrained (Phi=0) Unit Weight: 21 kN/m³ Cohesion: 75 kPa Piezometric Line: 1 B-bar: 0 Add Weight: No
 Name: Alluvial Deposit Model: Mohr-Coulomb Unit Weight: 18 kN/m³ Cohesion: 0 kPa Phi: 25 ° Piezometric Line: 1 B-bar: 0 Add Weight: No

A2
 After Excavation
 15 m Shear Key at 624 m

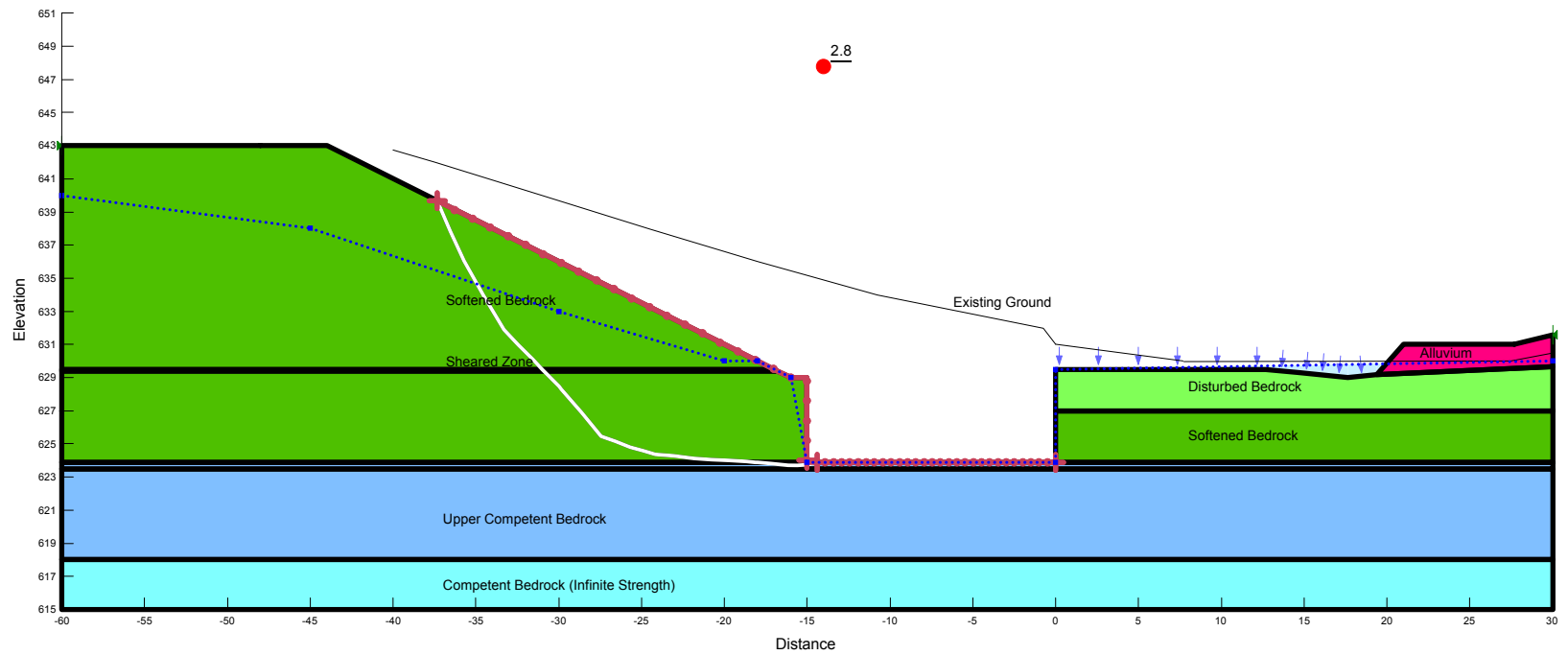

A3
 After Excavation
 16 m Shear Key at 624 m

Name: Clay Till Model: Undrained (Phi=0) Unit Weight: 20 kN/m³ Cohesion: 50 kPa Piezometric Line: 1 B-bar: 0 Add Weight: No
 Name: Disturbed Bedrock Model: Undrained (Phi=0) Unit Weight: 21 kN/m³ Cohesion: 75 kPa Piezometric Line: 1 B-bar: 0 Add Weight: No
 Name: Competent Bedrock (Infinite Strength) Model: Bedrock (Impenetrable) Piezometric Line: 1 B-bar: 0 Add Weight: No
 Name: Colluvium (Clay) Model: Undrained (Phi=0) Unit Weight: 18 kN/m³ Cohesion: 30 kPa Piezometric Line: 1 B-bar: 0 Add Weight: No
 Name: Alluvium Deposits Model: Mohr-Coulomb Unit Weight: 18 kN/m³ Cohesion: 0 kPa Phi: 25° Piezometric Line: 1 B-bar: 0 Add Weight: No
 Name: Softened Bedrock Model: Undrained (Phi=0) Unit Weight: 21 kN/m³ Cohesion: 100 kPa Piezometric Line: 1 B-bar: 0 Add Weight: No
 Name: Sheared Zone Model: Mohr-Coulomb Unit Weight: 21 kN/m³ Cohesion: 0 kPa Phi: 14° Piezometric Line: 1 B-bar: 0 Add Weight: No
 Name: Upper Competent Bedrock Model: Undrained (Phi=0) Unit Weight: 21 kN/m³ Cohesion: 200 kPa Piezometric Line: 1 B-bar: 0 Add Weight: No

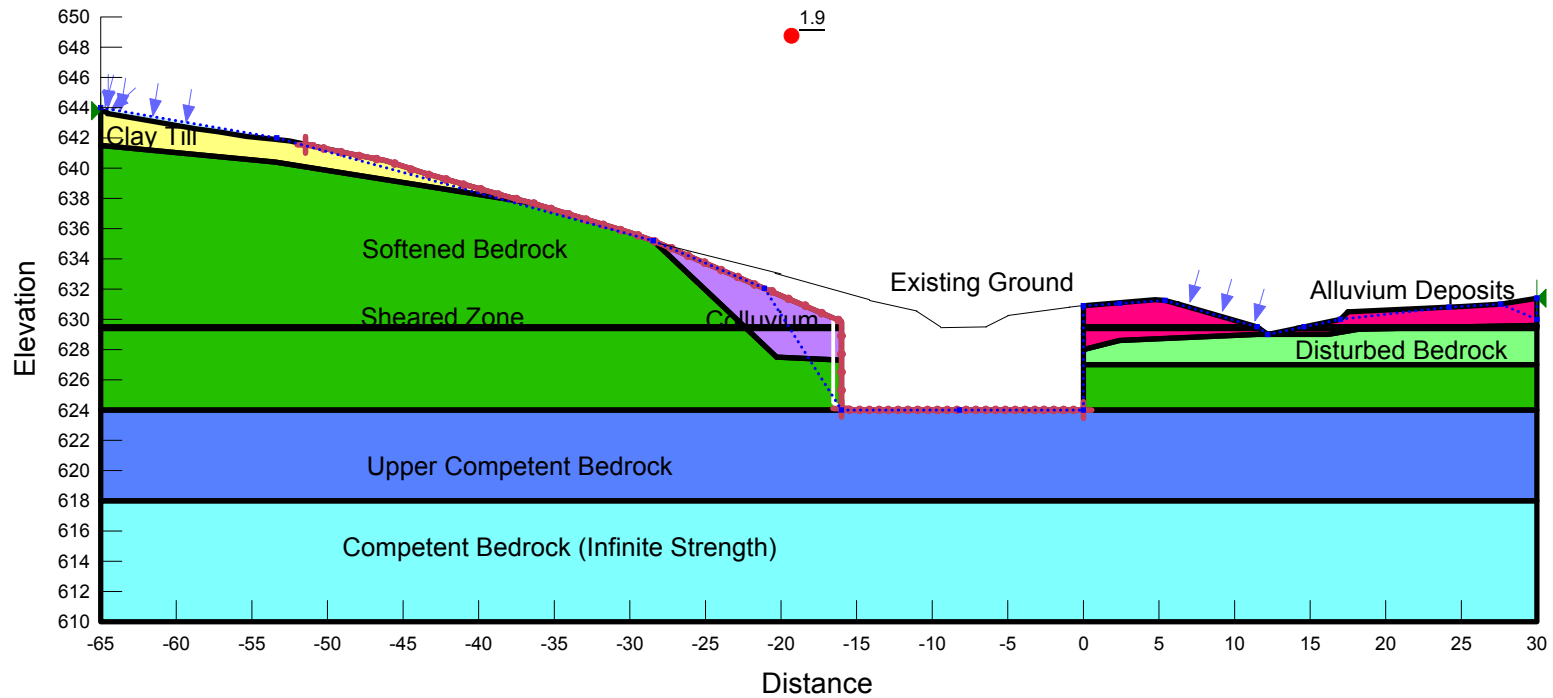

Color	Name	Model	Unit Weight (kN/m³)	Cohesion (kPa)	Piezometric Line	B-bar	Add Weight	Cohesion' (kPa)	Phi' (°)
Yellow	Clay Till	Undrained (Phi=0)	20	50	1	0	No		
Light Green	Disturbed Bedrock	Undrained (Phi=0)	21	75	1	0	No		
Dark Green	Softened Bedrock	Mohr-Coulomb	21		1	0	No	100	25
Light Blue	Upper Competent Bedrock	Mohr-Coulomb	21		1	0	No	200	25
Dark Blue	Sheared Zone	Mohr-Coulomb	20		1	0	No	0	14

B1
After Excavation
16 m Key at 626 m

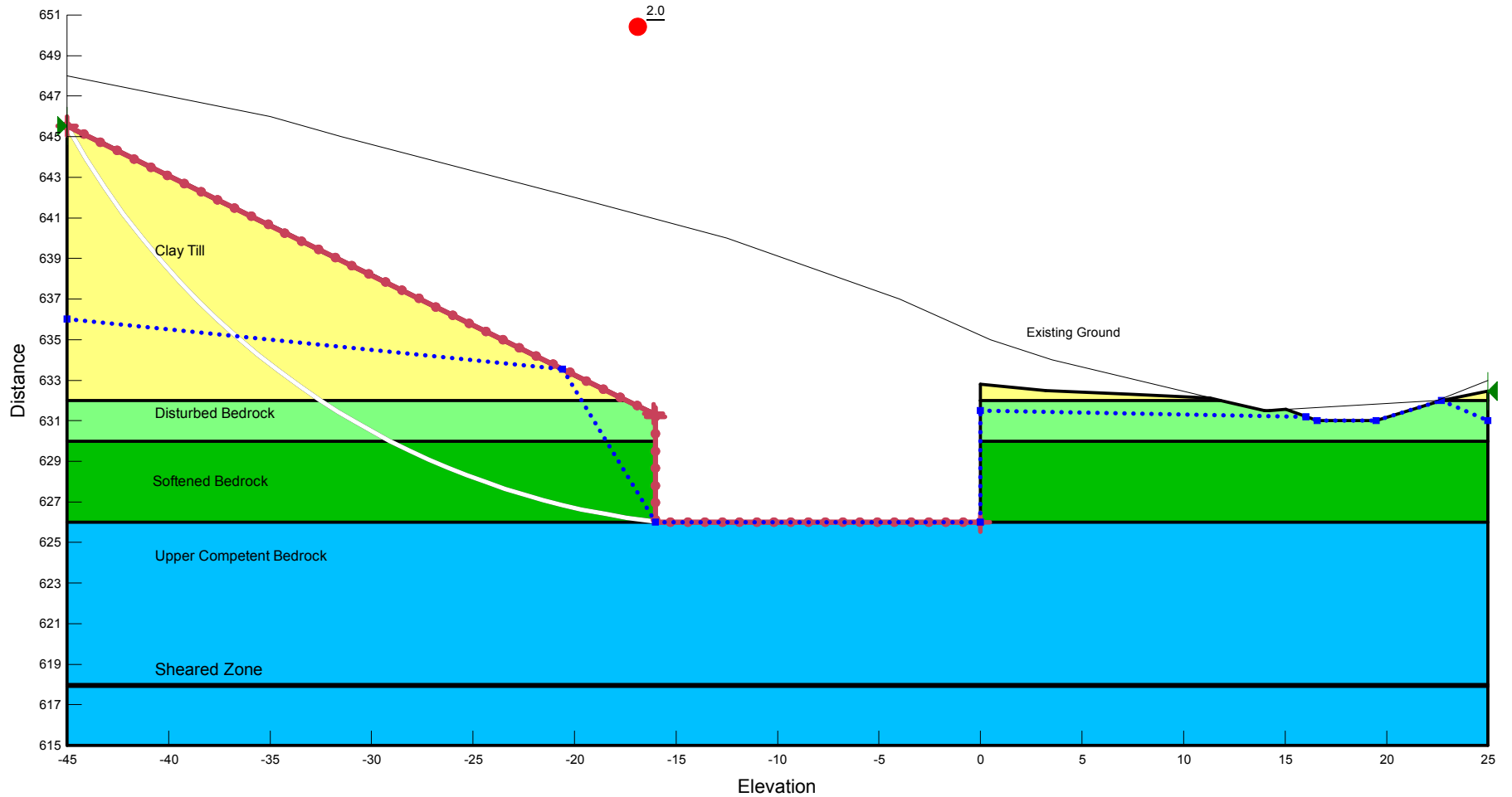

Color	Name	Model	Unit Weight (kN/m ³)	Cohesion (kPa)	Piezometric Line	Cohesion' (kPa)	Phi' (°)
Yellow	Clay Till	Undrained (Phi=0)	20	50	1		
Light Green	Disturbed Bedrock	Undrained (Phi=0)	21	75	1		
Light Blue	Upper Competent Bedrock	Undrained (Phi=0)	21	200	1		
Purple	Colluvium (Clay)	Undrained (Phi=0)	18	30	1		
Pink	Alluvium Deposits	Undrained (Phi=0)	18	30	1		
Dark Green	Softened Bedrock	Undrained (Phi=0)	21	100	1		
Light Blue	Sand (SP-SM)	Mohr-Coulomb	20		1	0	32
Dark Blue	Sheared Zone	Mohr-Coulomb	20		1	0	14

B2
After Excavation
15 m Shear Key at 630 m

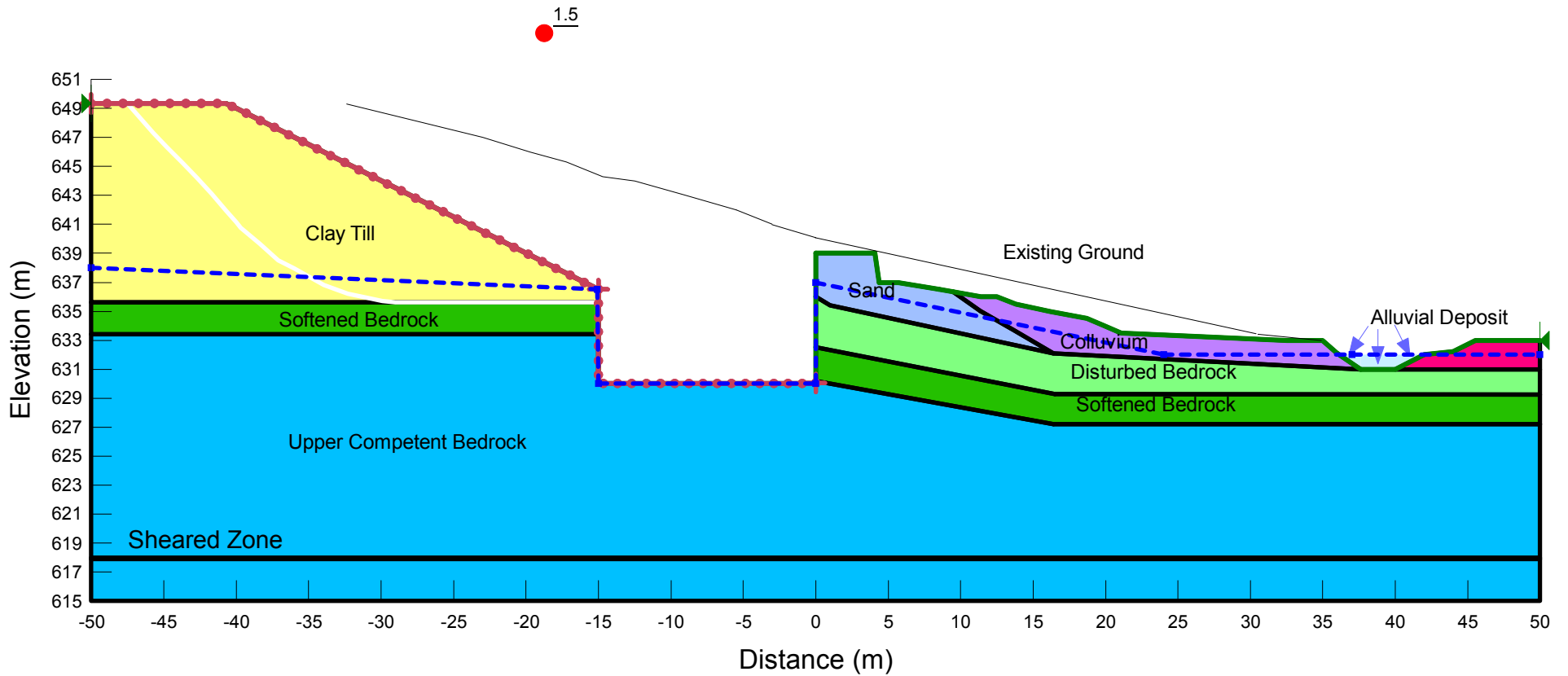

Color	Name	Model	Unit Weight (kN/m ³)	Cohesion (kPa)	Piezometric Line	B-bar	Add Weight
Light Green	Disturbed Bedrock	Undrained (Phi=0)	21	75	1	0	No
Dark Green	Softened Bedrock	Undrained (Phi=0)	21	100	1	0	No
Blue	Upper Competent Bedrock	Undrained (Phi=0)	21	200	1	0	No
Purple	Colluvium (Clay)	Undrained (Phi=0)	18	30	1	0	No

C3
 After Excavation
 14 m Shear Key at 626 m

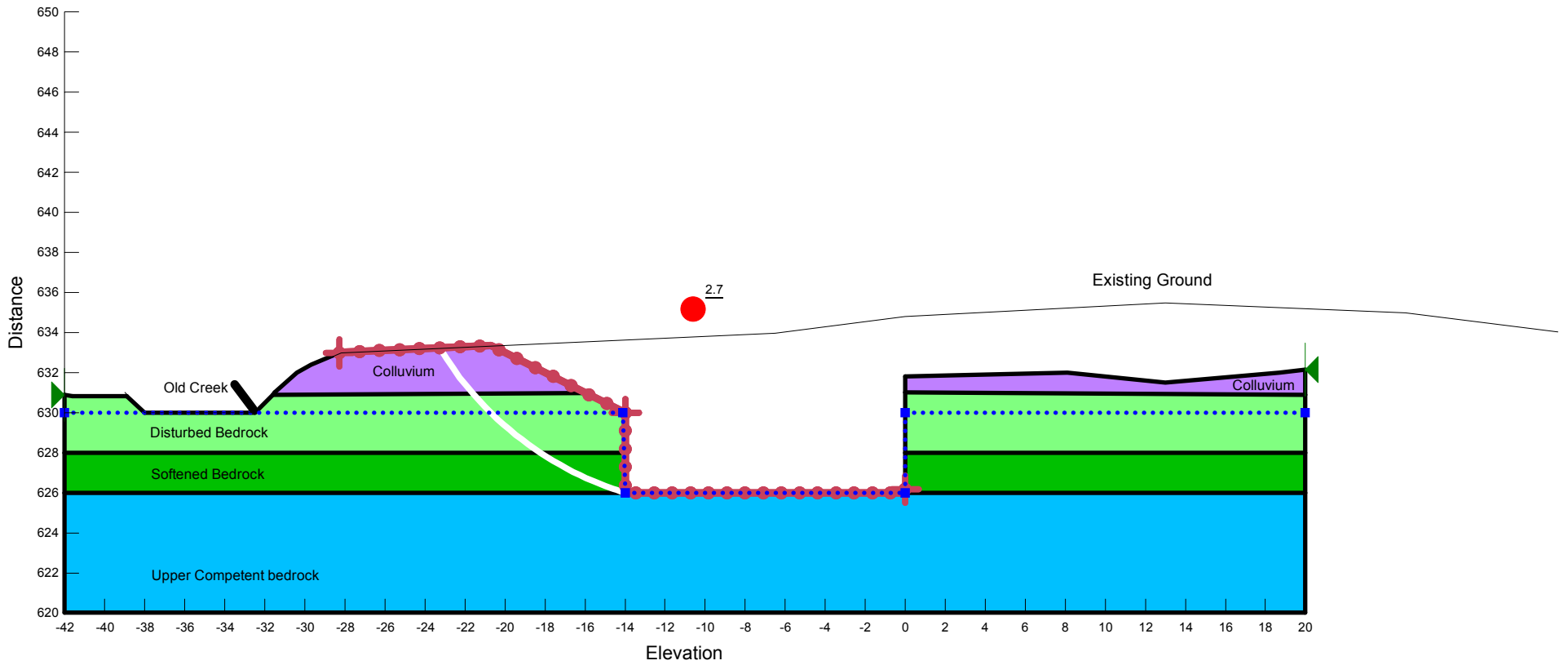

Color	Name	Model	Unit Weight (kN/m ³)	Cohesion (kPa)	Piezometric Line	B-bar	Add Weight	Cohesion' (kPa)	Phi' (°)
Yellow	Clay Till	Undrained (Phi=0)	20	50	1	0	No		
Light Green	Clay Fill	Mohr-Coulomb	20			0	Yes	5	28
Light Green	Disturbed Bedrock	Undrained (Phi=0)	21	75	1	0	No		
Blue	Upper Competent Bedrock	Undrained (Phi=0)	21	200	1	0	No		
Green	Softened Bedrock	Undrained (Phi=0)	21	100	1	0	No		
Dark Blue	Sheared Zone	Mohr-Coulomb	21		1	0	No	0	14

D1
After Excavation
13 m shear key at 626 m

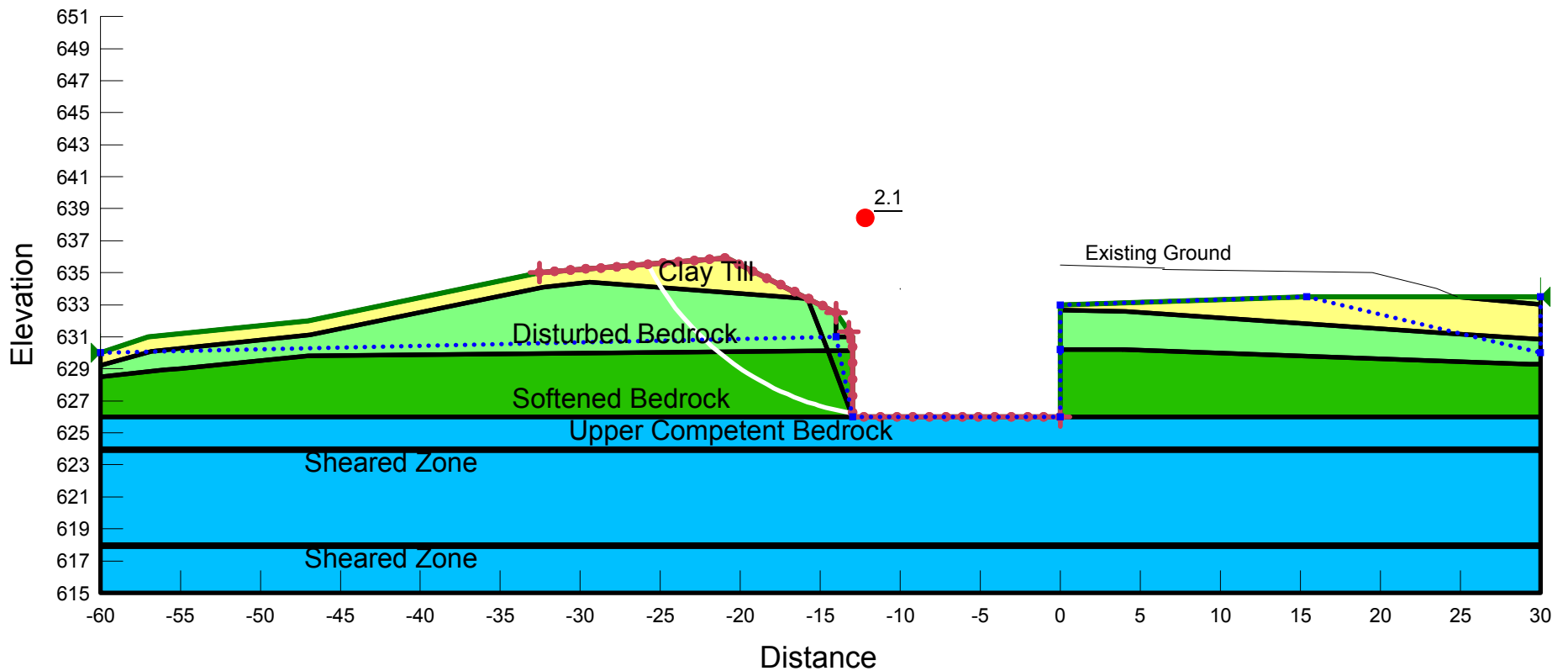

Color	Name	Model	Unit Weight (kN/m ³)	Cohesion (kPa)	Phi (°)	Piezometric Line	B-bar	Add Weight
Yellow	Clay Till	Mohr-Coulomb	20	5	28	1	0.2	No
Light Green	Clay Fill	Mohr-Coulomb	20	5	28	1	0.2	Yes
Green	Disturbed Bedrock	Mohr-Coulomb	21	0	14	1	0.4	No
Dark Green	Softened Bedrock	Mohr-Coulomb	21	0	25	1	0.4	No
Blue	Upper Competent Bedrock	Mohr-Coulomb	21	50	25	1	0.4	No
Purple	Colluvium (Clay)	Mohr-Coulomb	18	0	25	1	0.4	No
Pink	MSE Wall Fill	Mohr-Coulomb	20	200	30	1	0	Yes
Orange	Shear Key	Mohr-Coulomb	20	0	35	1	0	No
Dark Blue	Sheared Zone	Mohr-Coulomb	20	0	14	1	0	No
Magenta	Alluvial Deposit	Mohr-Coulomb	18	0	25	1	0	No
Cyan	Intermediate Bedrock	Mohr-Coulomb	21	25	25	1	0.4	No

A1
EOC
10 m Wall at 636 m
10 m Key at 634 m
1.5 m Embedment

3 Piles
Shear Force = 500 kN
Shear Reduction Factor = 0.7
Spacing = 3.5 m

1.9

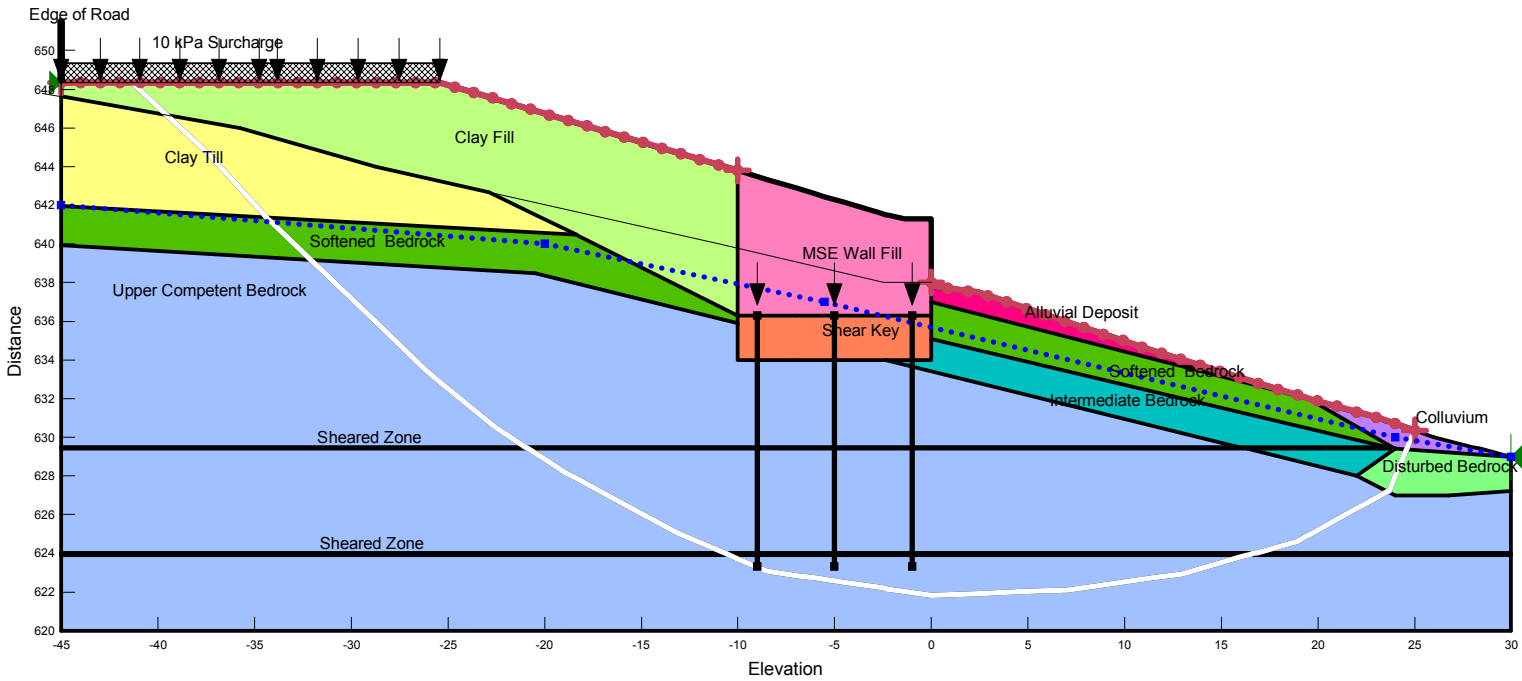

Color	Name	Model	Unit Weight (kN/m ³)	Cohesion' (kPa)	Phi' (°)	Piezometric Line
Yellow	Clay Till	Mohr-Coulomb	20	5	28	1
Light Green	Clay Fill	Mohr-Coulomb	20	5	28	1
Light Green	Disturbed Bedrock	Mohr-Coulomb	21	0	14	1
Dark Green	Softened Bedrock	Mohr-Coulomb	21	0	25	1
Blue	Upper Competent Bedrock	Mohr-Coulomb	21	50	25	1
Purple	Colluvium (Clay)	Mohr-Coulomb	18	0	25	1
Pink	MSE Wall Fill	Mohr-Coulomb	20	200	30	1
Orange	Shear Key	Mohr-Coulomb	20	0	35	1
Dark Blue	Sheared Zone	Mohr-Coulomb	20	0	14	1
Magenta	Alluvial Deposit	Mohr-Coulomb	18	0	25	1
Cyan	Intermediate Bedrock	Mohr-Coulomb	21	25	25	1

A1
 LT
 10 m Wall at 636 m
 10 m Key at 634 m
 1.5 m Embedment
 Increased GWT

3 Piles
 Shear Force = 500 kN
 Shear Reduction Factor = 0.7
 Spacing = 3.5 m

2.0

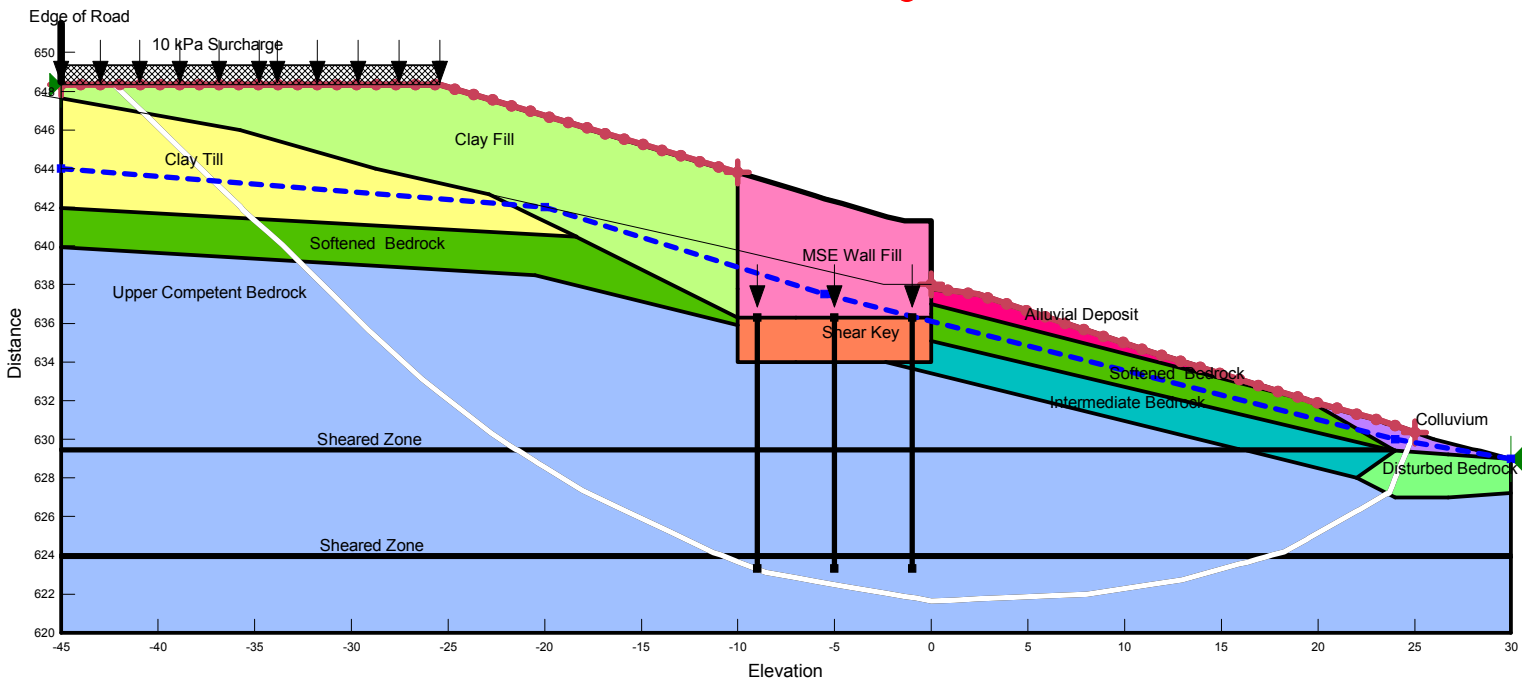

Color	Name	Model	Unit Weight (kN/m ³)	Cohesion (kPa)	Phi (°)	Piezometric Line	B-bar	Add Weight
Light Green	Clay Fill	Mohr-Coulomb	20	5	28	1	0.2	Yes
Dark Blue	Sheared Zone	Mohr-Coulomb	20	0	14	1	0.4	No
Green	Softened Bedrock	Mohr-Coulomb	21	0	25	1	0.4	No
Cyan	Competent Bedrock (Infinite Strength)	Bedrock (Impenetrable)				1	0.4	No
Light Blue	Upper Competent Bedrock	Mohr-Coulomb	21	50	25	1	0.4	No
Pink	MSE Wall Fill	Mohr-Coulomb	20	200	30	1	0	Yes
Light Green	Disturbed Bedrock	Mohr-Coulomb	21	0	14	1	0.4	No
Orange	Shear Key	Mohr-Coulomb	20	0	35	1	0	No
Magenta	Alluvial Deposit	Mohr-Coulomb	18	0	25	1	0	No

A2
EOC
16 m Wide Wall at 629 m
15 m Shear Key at 624 m
5 m embedment

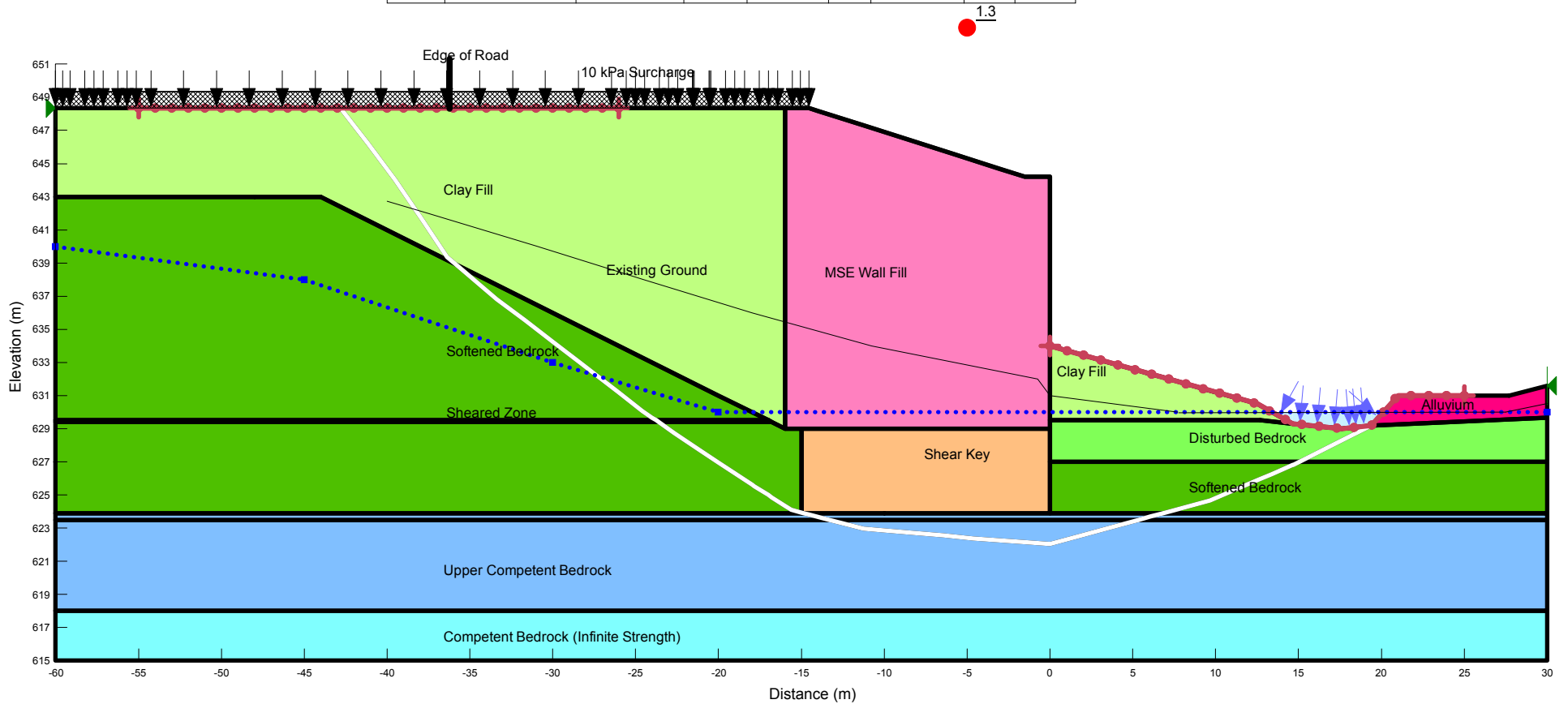

Color	Name	Model	Unit Weight (kN/m ³)	Cohesion (kPa)	Phi (°)	Piezometric Line
Light Green	Clay Fill	Mohr-Coulomb	20	5	28	1
Dark Blue	Sheared Zone	Mohr-Coulomb	20	0	14	1
Dark Green	Softened Bedrock	Mohr-Coulomb	21	0	25	1
Cyan	Competent Bedrock (Infinite Strength)	Bedrock (Impenetrable)				1
Light Blue	Upper Competent Bedrock	Mohr-Coulomb	21	50	25	1
Pink	MSE Wall Fill	Mohr-Coulomb	20	200	30	1
Light Green	Disturbed Bedrock	Mohr-Coulomb	21	0	14	1
Orange	Shear Key	Mohr-Coulomb	20	0	35	1
Magenta	Alluvial Deposit	Mohr-Coulomb	18	0	25	1

A2
 LT
 16 m Wide Wall at 629 m
 15 m Shear Key at 624 m
 5 m embedment
 Increased GWT

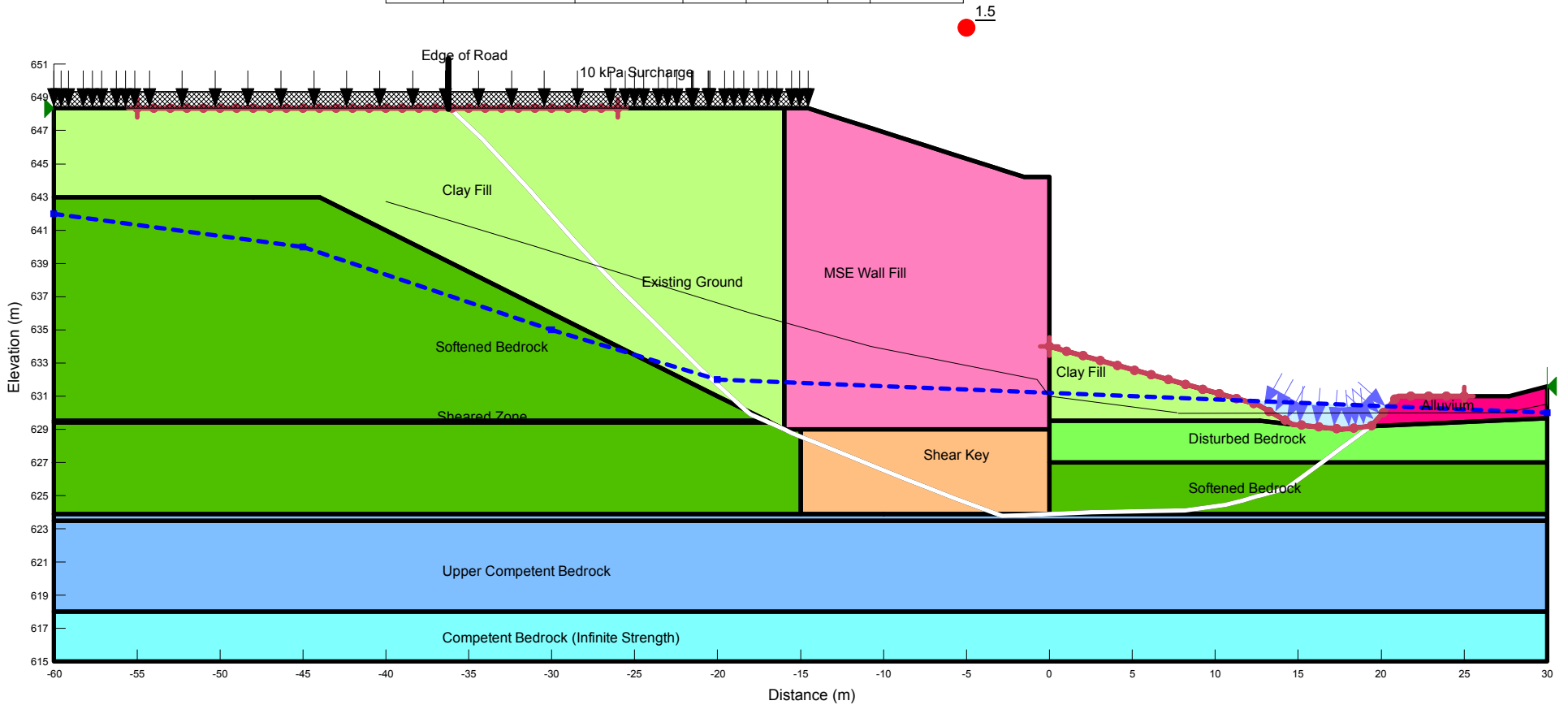

Color	Name	Model	Unit Weight (kN/m ³)	Cohesion' (kPa)	Phi' (°)	Piezometric Line	B-bar	Add Weight
Yellow	Clay Till	Mohr-Coulomb	20	5	28	1	0.2	No
Light Green	Disturbed Bedrock	Mohr-Coulomb	21	0	14	1	0.4	No
Cyan	Competent Bedrock (Infinite Strength)	Bedrock (Impenetrable)				1	0.4	No
Orange	Shear Key	Mohr-Coulomb	21	0	35	1	0	No
Purple	Colluvium (Clay)	Mohr-Coulomb	18	0	25	1	0.4	No
Pink	MSE Wall Fill	Mohr-Coulomb	20	200	30	1	0	Yes
Magenta	Alluvium Deposits	Mohr-Coulomb	18	0	25	1	0	No
Dark Green	Softened Bedrock	Mohr-Coulomb	21	0	25	1	0.4	No
Dark Blue	Sheared Zone	Mohr-Coulomb	21	0	14	1	0.4	No
Blue	Upper Competent Bedrock	Mohr-Coulomb	21	50	25	1	0	No
Light Green	Clay Fill	Mohr-Coulomb	20	5	28	1	0.2	No

A3
 EOC
 16 m MSE Wall at 629 m
 16 m Shear Key at 624 m
 3 m embedment

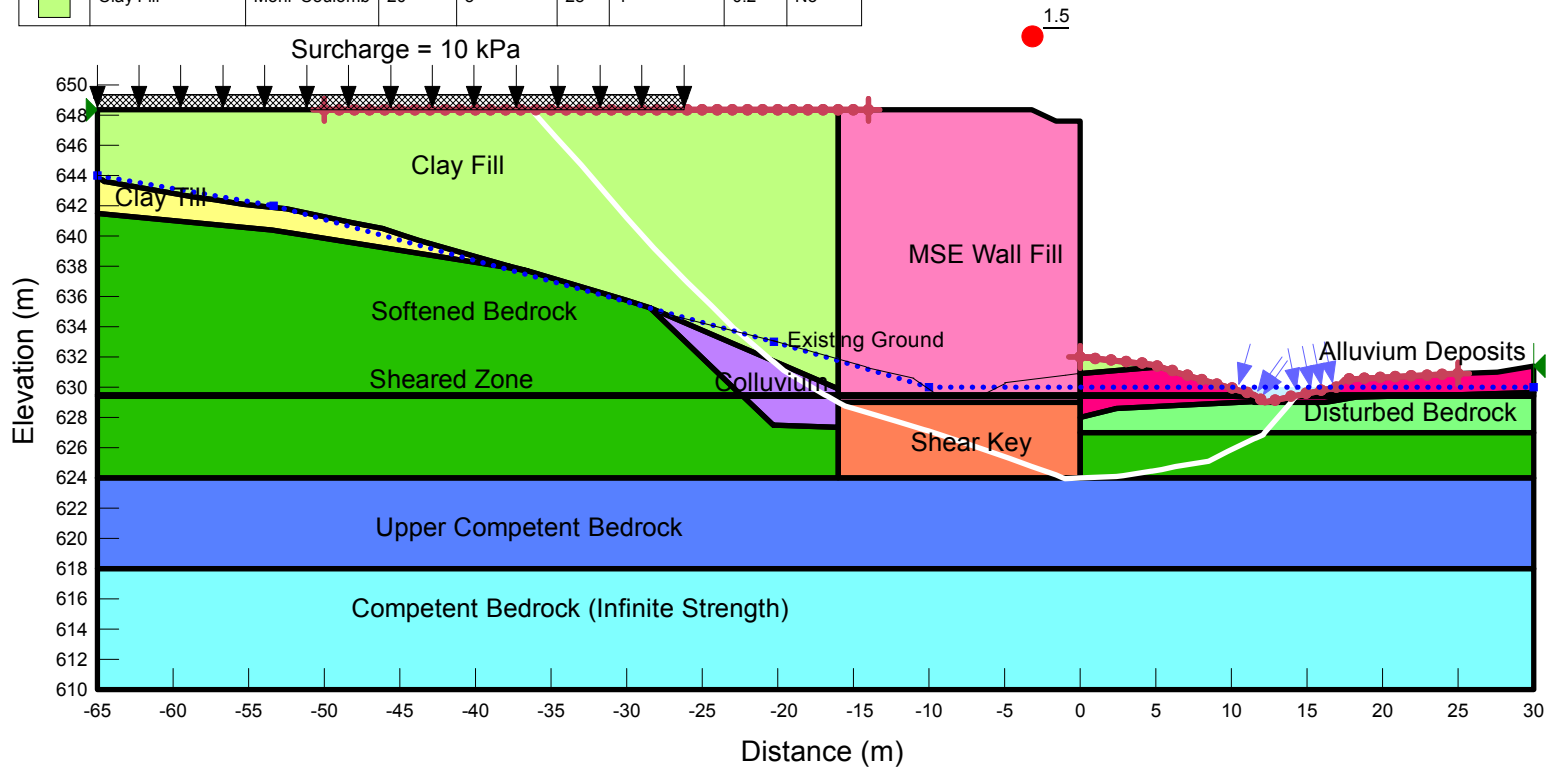

Color	Name	Model	Unit Weight (kN/m ³)	Cohesion' (kPa)	Phi' (°)	Piezometric Line
Yellow	Clay Till	Mohr-Coulomb	20	5	28	1
Light Green	Disturbed Bedrock	Mohr-Coulomb	21	0	14	1
Cyan	Competent Bedrock (Infinite Strength)	Bedrock (Impenetrable)				1
Orange	Shear Key	Mohr-Coulomb	21	0	35	1
Purple	Colluvium (Clay)	Mohr-Coulomb	18	0	25	1
Pink	MSE Wall Fill	Mohr-Coulomb	20	200	30	1
Magenta	Alluvium Deposits	Mohr-Coulomb	18	0	25	1
Dark Green	Softened Bedrock	Mohr-Coulomb	21	0	25	1
Blue	Upper Competent Bedrock	Mohr-Coulomb	21	50	25	1
Light Green	Clay Fill	Mohr-Coulomb	20	5	28	1

A3
 LT
 16 m MSE Wall at 629 m
 16 m Shear Key at 624 m
 3 m embedment
 Increased GWT

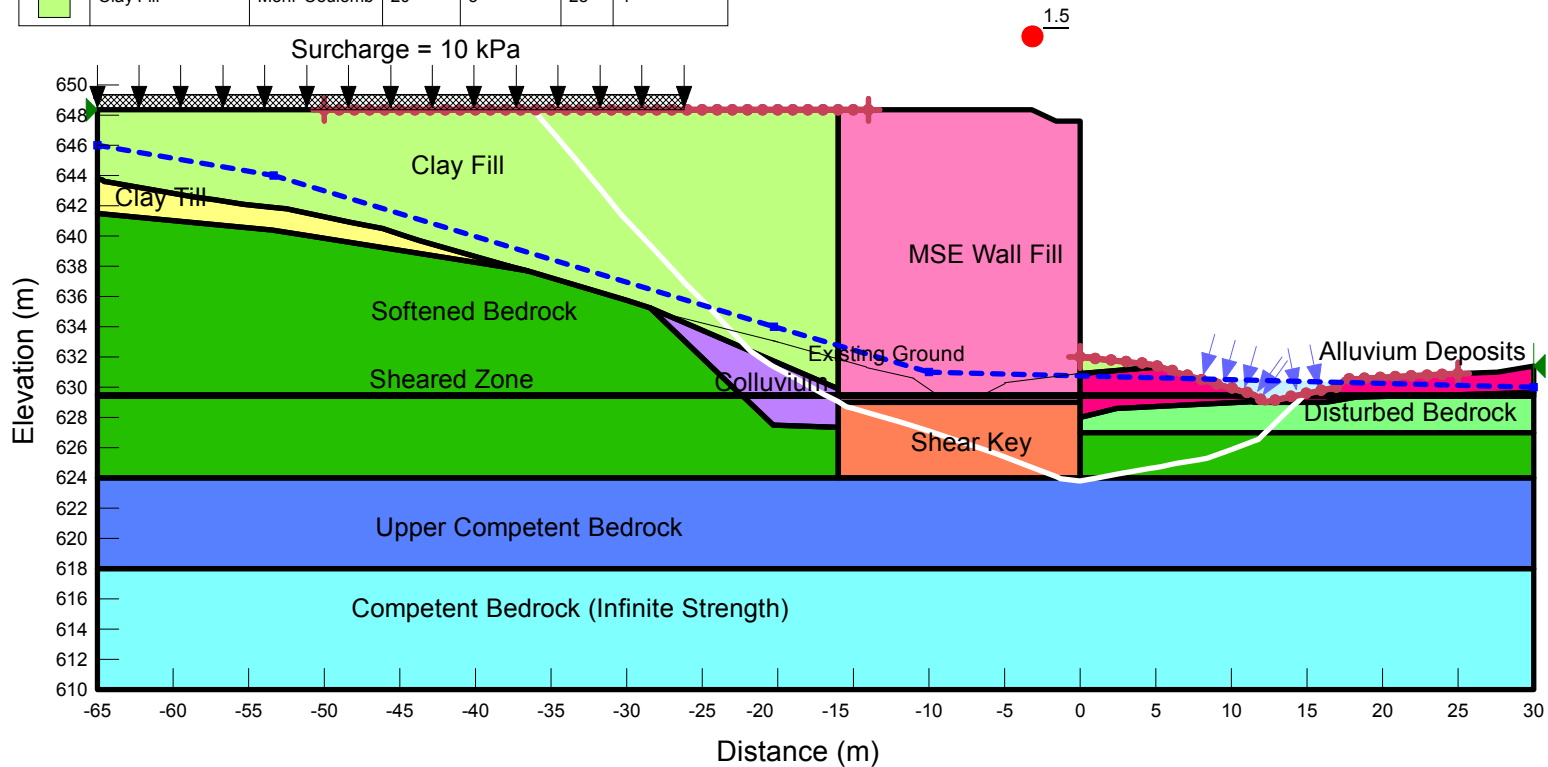

Name: Clay Till Model: Mohr-Coulomb Unit Weight: 20 kN/m³ Cohesion: 5 kPa Phi: 28 ° Piezometric Line: 1 B-bar: 0.2 Add Weight: No
 Name: Clay Fill Model: Mohr-Coulomb Unit Weight: 20 kN/m³ Cohesion: 5 kPa Phi: 28 ° Piezometric Line: 1 B-bar: 0.2 Add Weight: Yes
 Name: Disturbed Bedrock Model: Mohr-Coulomb Unit Weight: 21 kN/m³ Cohesion: 0 kPa Phi: 14 ° Piezometric Line: 1 B-bar: 0.4 Add Weight: No
 Name: Softened Bedrock Model: Mohr-Coulomb Unit Weight: 21 kN/m³ Cohesion: 0 kPa Phi: 25 ° Piezometric Line: 1 B-bar: 0.4 Add Weight: No
 Name: Upper Competent Bedrock Model: Mohr-Coulomb Unit Weight: 21 kN/m³ Cohesion: 50 kPa Phi: 25 ° Piezometric Line: 1 B-bar: 0.4 Add Weight: No
 Name: MSE Wall Fill Model: Mohr-Coulomb Unit Weight: 20 kN/m³ Cohesion: 200 kPa Phi: 30 ° Piezometric Line: 1 B-bar: 0 Add Weight: Yes
 Name: Shear Key Model: Mohr-Coulomb Unit Weight: 20 kN/m³ Cohesion: 0 kPa Phi: 35 ° Piezometric Line: 1 B-bar: 0 Add Weight: No
 Name: Sheared Zone Model: Mohr-Coulomb Unit Weight: 20 kN/m³ Cohesion: 0 kPa Phi: 14 ° Piezometric Line: 1 B-bar: 0 Add Weight: No

B1
 EOC
 16 m Wide Wall
 Wall base at 631 m
 16 m Key at 626 m
 1.5 m embedment

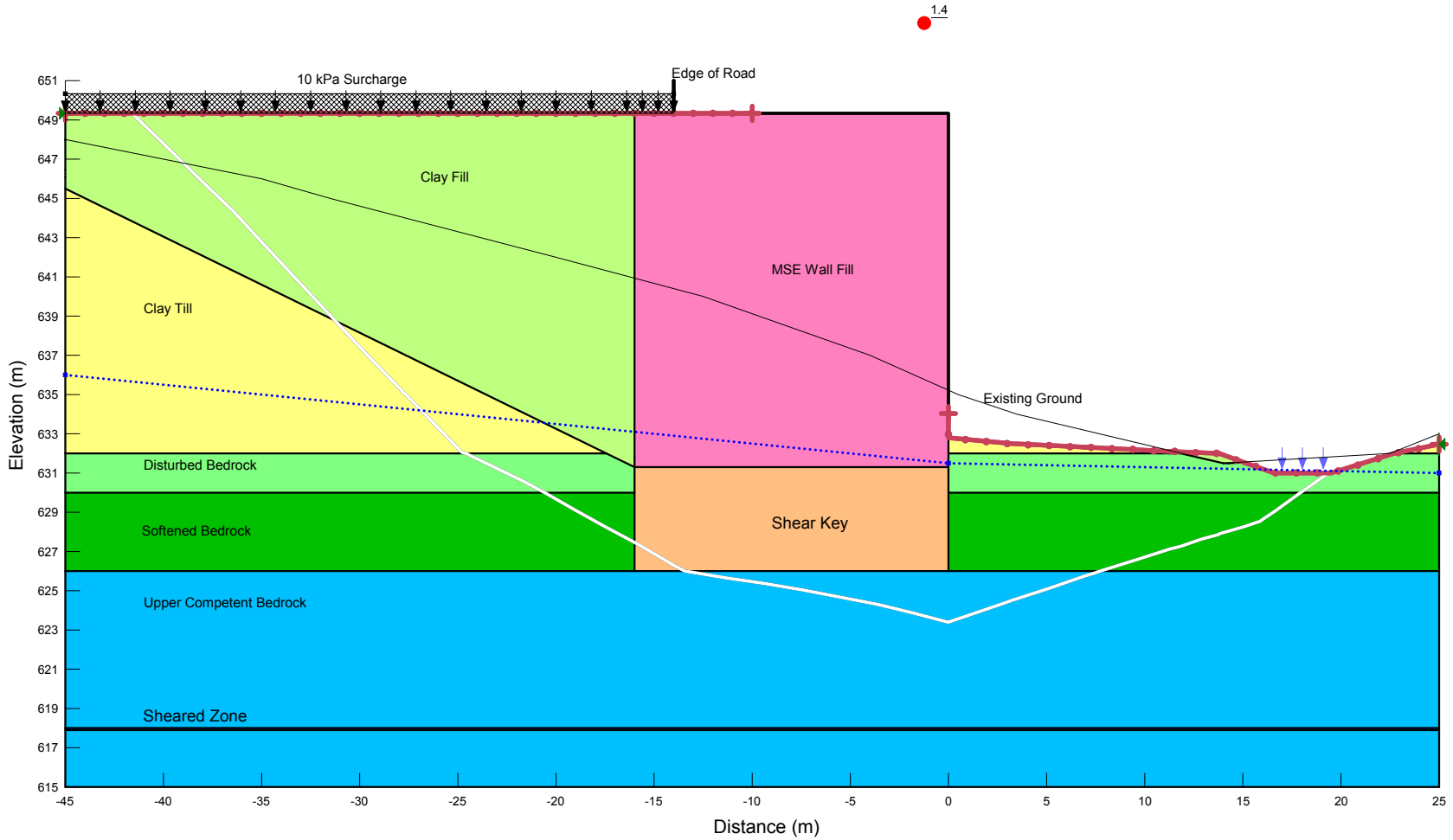

Name: Clay Till Model: Mohr-Coulomb Unit Weight: 20 kN/m³ Cohesion: 5 kPa Phi: 28 ° Piezometric Line: 1
 Name: Clay Fill Model: Mohr-Coulomb Unit Weight: 20 kN/m³ Cohesion: 5 kPa Phi: 28 ° Piezometric Line: 1
 Name: Disturbed Bedrock Model: Mohr-Coulomb Unit Weight: 21 kN/m³ Cohesion: 0 kPa Phi: 14 ° Piezometric Line: 1
 Name: Softened Bedrock Model: Mohr-Coulomb Unit Weight: 21 kN/m³ Cohesion: 0 kPa Phi: 25 ° Piezometric Line: 1
 Name: Upper Competent Bedrock Model: Mohr-Coulomb Unit Weight: 21 kN/m³ Cohesion: 50 kPa Phi: 25 ° Piezometric Line: 1
 Name: MSE Wall Fill Model: Mohr-Coulomb Unit Weight: 20 kN/m³ Cohesion: 200 kPa Phi: 30 ° Piezometric Line: 1
 Name: Shear Key Model: Mohr-Coulomb Unit Weight: 20 kN/m³ Cohesion: 0 kPa Phi: 35 ° Piezometric Line: 1
 Name: Sheared Zone Model: Mohr-Coulomb Unit Weight: 20 kN/m³ Cohesion: 0 kPa Phi: 14 ° Piezometric Line: 1

B1
 LT
 16 m Wide Wall
 Wall base at 631 m
 16 m Key at 626 m
 1.5 m embedment
 Increased GWT

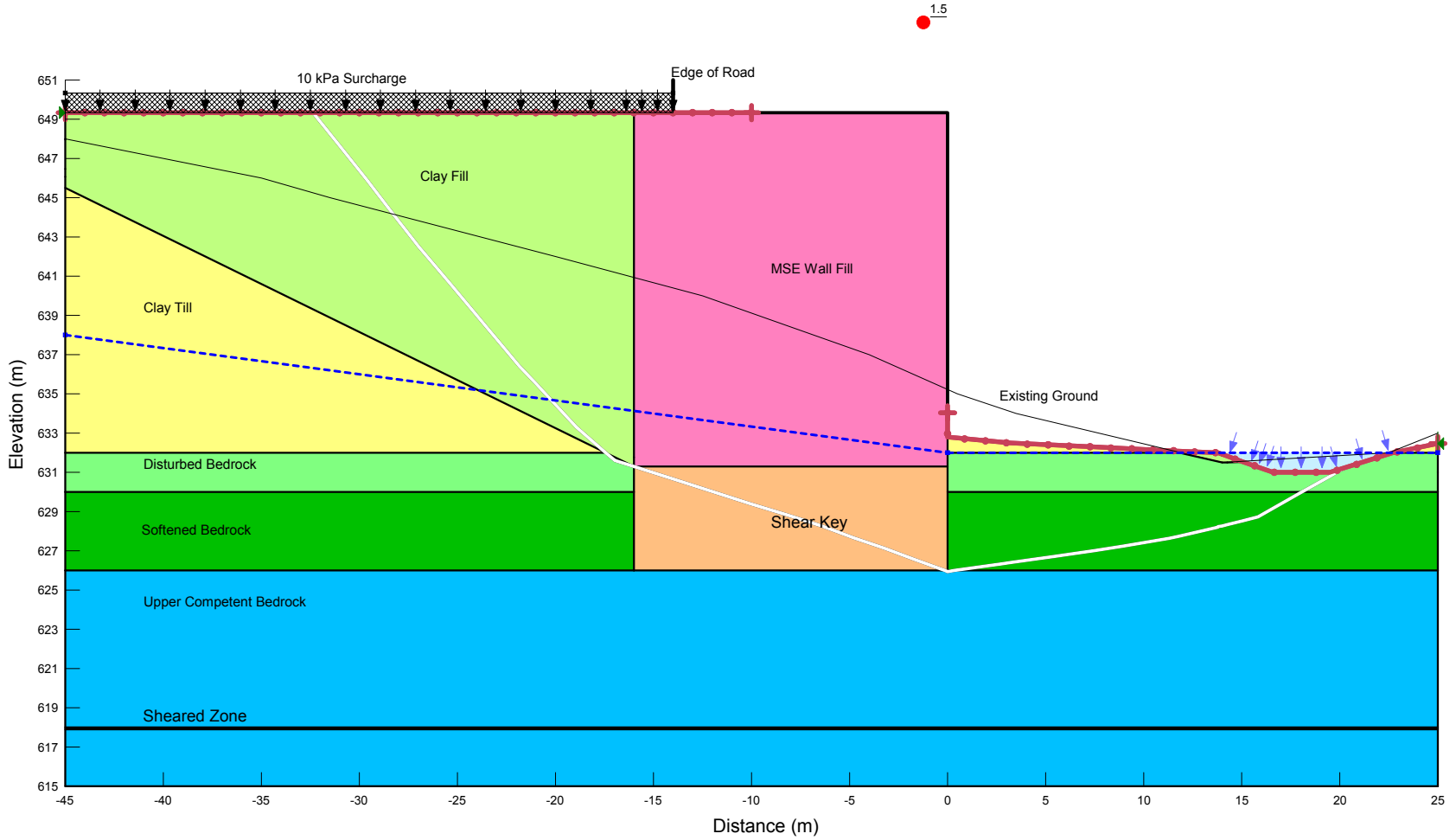

B2
 EOC
 15 m MSE Wall at 636 m
 15 m Shear Key at 630 m
 3 m embedment

Name: Clay Till	Model: Mohr-Coulomb	Unit Weight: 20 kN/m ³	Cohesion': 5 kPa	Phi': 28 °	Piezometric Line: 1	B-bar: 0.2	Add Weight: No
Name: Clay Fill	Model: Mohr-Coulomb	Unit Weight: 20 kN/m ³	Cohesion': 5 kPa	Phi': 28 °	B-bar: 0.2	Add Weight: Yes	
Name: Disturbed Bedrock	Model: Mohr-Coulomb	Unit Weight: 21 kN/m ³	Cohesion': 0 kPa	Phi': 14 °	Piezometric Line: 1	B-bar: 0.4	Add Weight: No
Name: Upper Competent Bedrock	Model: Mohr-Coulomb	Unit Weight: 21 kN/m ³	Cohesion': 50 kPa	Phi': 25 °	Piezometric Line: 1	B-bar: 0.4	Add Weight: No
Name: Colluvium (Clay)	Model: Mohr-Coulomb	Unit Weight: 18 kN/m ³	Cohesion': 0 kPa	Phi': 25 °	Piezometric Line: 1	B-bar: 0.4	Add Weight: No
Name: MSE Wall Fill	Model: Mohr-Coulomb	Unit Weight: 20 kN/m ³	Cohesion': 200 kPa	Phi': 30 °	Piezometric Line: 1	B-bar: 0	Add Weight: Yes
Name: Alluvium Deposits	Model: Mohr-Coulomb	Unit Weight: 18 kN/m ³	Cohesion': 0 kPa	Phi': 25 °	Piezometric Line: 1	B-bar: 0	Add Weight: No
Name: Softened Bedrock	Model: Mohr-Coulomb	Unit Weight: 21 kN/m ³	Cohesion': 0 kPa	Phi': 25 °	Piezometric Line: 1	B-bar: 0.4	Add Weight: No
Name: Shear Key	Model: Mohr-Coulomb	Unit Weight: 20 kN/m ³	Cohesion': 0 kPa	Phi': 35 °	Piezometric Line: 1	B-bar: 0	Add Weight: No
Name: Sand (SP-SM)	Model: Mohr-Coulomb	Unit Weight: 20 kN/m ³	Cohesion': 0 kPa	Phi': 32 °	Piezometric Line: 1	B-bar: 0	Add Weight: No
Name: Sheared Zone	Model: Mohr-Coulomb	Unit Weight: 20 kN/m ³	Cohesion': 0 kPa	Phi': 14 °	Piezometric Line: 1	B-bar: 0	Add Weight: No

1.5

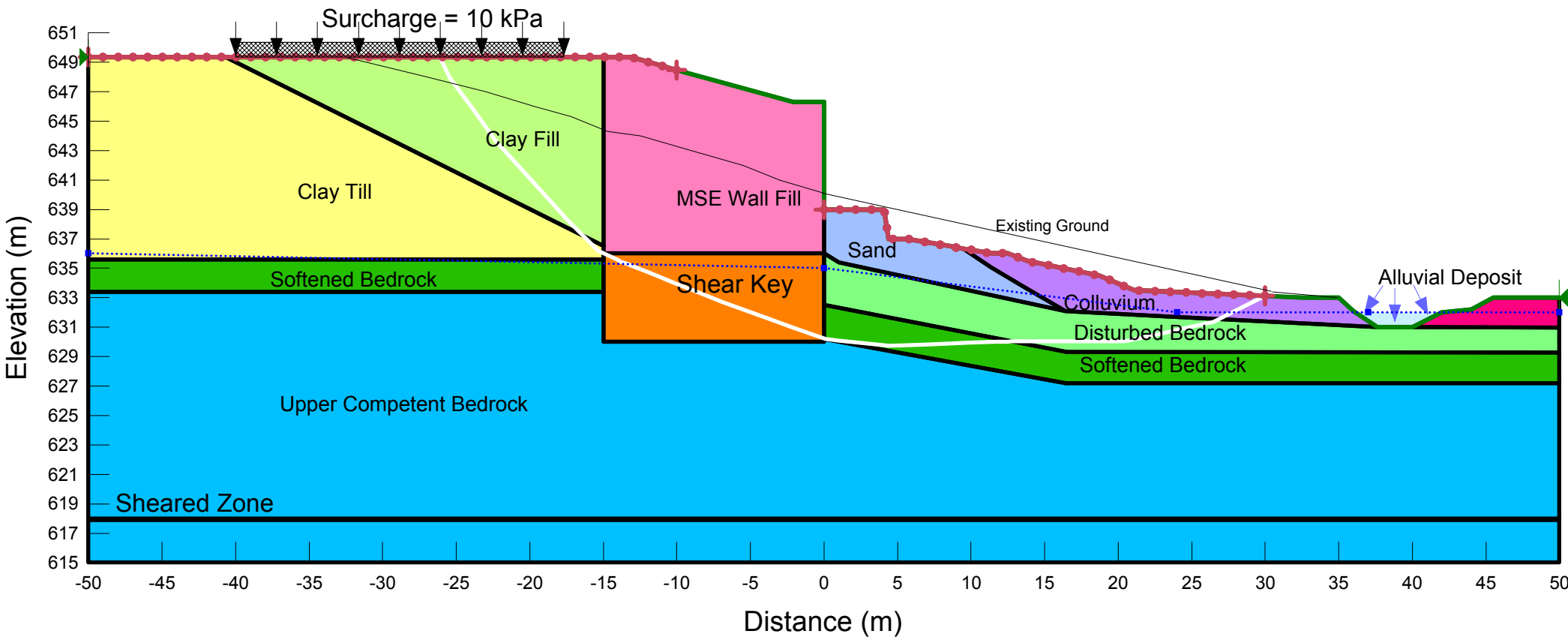

B2
 LT
 15 m MSE Wall at 636 m
 15 m Shear Key at 630 m
 3 m embedment
 GWT Increased

Name: Clay Till Model: Mohr-Coulomb Unit Weight: 20 kN/m³ Cohesion: 5 kPa Phi: 28 ° Piezometric Line: 1
 Name: Clay Fill Model: Mohr-Coulomb Unit Weight: 20 kN/m³ Cohesion: 5 kPa Phi: 28 °
 Name: Disturbed Bedrock Model: Mohr-Coulomb Unit Weight: 21 kN/m³ Cohesion: 0 kPa Phi: 14 ° Piezometric Line: 1
 Name: Upper Competent Bedrock Model: Mohr-Coulomb Unit Weight: 21 kN/m³ Cohesion: 50 kPa Phi: 25 ° Piezometric Line: 1
 Name: Colluvium (Clay) Model: Mohr-Coulomb Unit Weight: 18 kN/m³ Cohesion: 0 kPa Phi: 25 ° Piezometric Line: 1
 Name: MSE Wall Fill Model: Mohr-Coulomb Unit Weight: 20 kN/m³ Cohesion: 200 kPa Phi: 30 ° Piezometric Line: 1
 Name: Alluvium Deposits Model: Mohr-Coulomb Unit Weight: 18 kN/m³ Cohesion: 0 kPa Phi: 25 ° Piezometric Line: 1
 Name: Softened Bedrock Model: Mohr-Coulomb Unit Weight: 21 kN/m³ Cohesion: 0 kPa Phi: 25 ° Piezometric Line: 1
 Name: Shear Key Model: Mohr-Coulomb Unit Weight: 20 kN/m³ Cohesion: 0 kPa Phi: 35 ° Piezometric Line: 1
 Name: Sand (SP-SM) Model: Mohr-Coulomb Unit Weight: 20 kN/m³ Cohesion: 0 kPa Phi: 32 ° Piezometric Line: 1
 Name: Sheared Zone Model: Mohr-Coulomb Unit Weight: 20 kN/m³ Cohesion: 0 kPa Phi: 14 ° Piezometric Line: 1

1.5

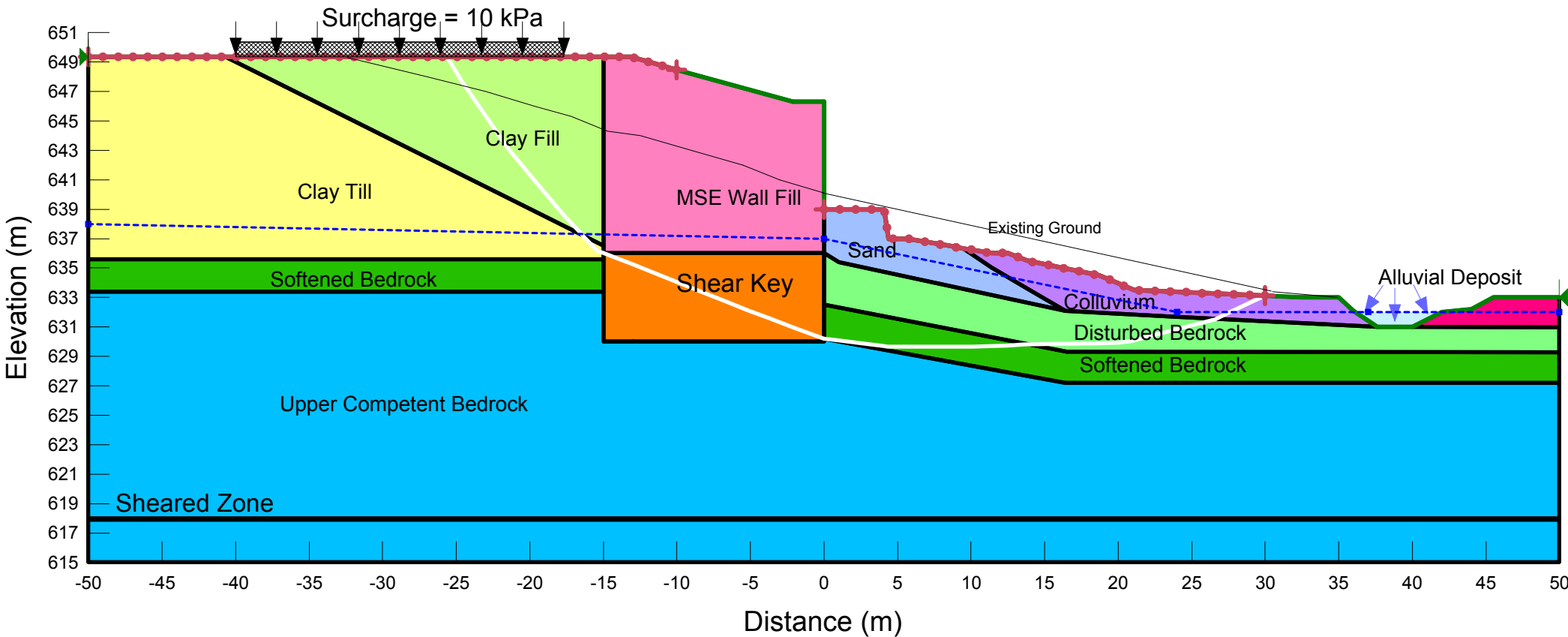

B3
 EOC
 12 m Wall, base at 640 m
 12 m Shear Key, base at 636 m
 1.5 m embedment

Name: Clay Till	Model: Mohr-Coulomb	Unit Weight: 20 kN/m ³	Cohesion: 5 kPa	Phi: 28 °	Piezometric Line: 1	B-bar: 0.2	Add Weight: No
Name: Clay Fill	Model: Mohr-Coulomb	Unit Weight: 20 kN/m ³	Cohesion: 5 kPa	Phi: 28 °	B-bar: 0.2	Add Weight: Yes	
Name: Disturbed Bedrock	Model: Mohr-Coulomb	Unit Weight: 21 kN/m ³	Cohesion: 0 kPa	Phi: 14 °	Piezometric Line: 1	B-bar: 0.4	Add Weight: No
Name: Upper Competent Bedrock	Model: Mohr-Coulomb	Unit Weight: 21 kN/m ³	Cohesion: 50 kPa	Phi: 25 °	Piezometric Line: 1	B-bar: 0.4	Add Weight: No
Name: Colluvium (Clay)	Model: Mohr-Coulomb	Unit Weight: 18 kN/m ³	Cohesion: 0 kPa	Phi: 25 °	Piezometric Line: 1	B-bar: 0.4	Add Weight: No
Name: MSE Wall Fill	Model: Mohr-Coulomb	Unit Weight: 20 kN/m ³	Cohesion: 200 kPa	Phi: 30 °	Piezometric Line: 1	Add Weight: Yes	
Name: Softened Bedrock	Model: Mohr-Coulomb	Unit Weight: 21 kN/m ³	Cohesion: 0 kPa	Phi: 25 °	Piezometric Line: 1	B-bar: 0.4	Add Weight: No
Name: Shear Key	Model: Mohr-Coulomb	Unit Weight: 20 kN/m ³	Cohesion: 0 kPa	Phi: 35 °	Piezometric Line: 1	Add Weight: No	
Name: Sand (SP-SM)	Model: Mohr-Coulomb	Unit Weight: 20 kN/m ³	Cohesion: 0 kPa	Phi: 32 °	Piezometric Line: 1	Add Weight: No	
Name: Sheared Zone	Model: Mohr-Coulomb	Unit Weight: 20 kN/m ³	Cohesion: 0 kPa	Phi: 14 °	Piezometric Line: 1	B-bar: 0	Add Weight: No

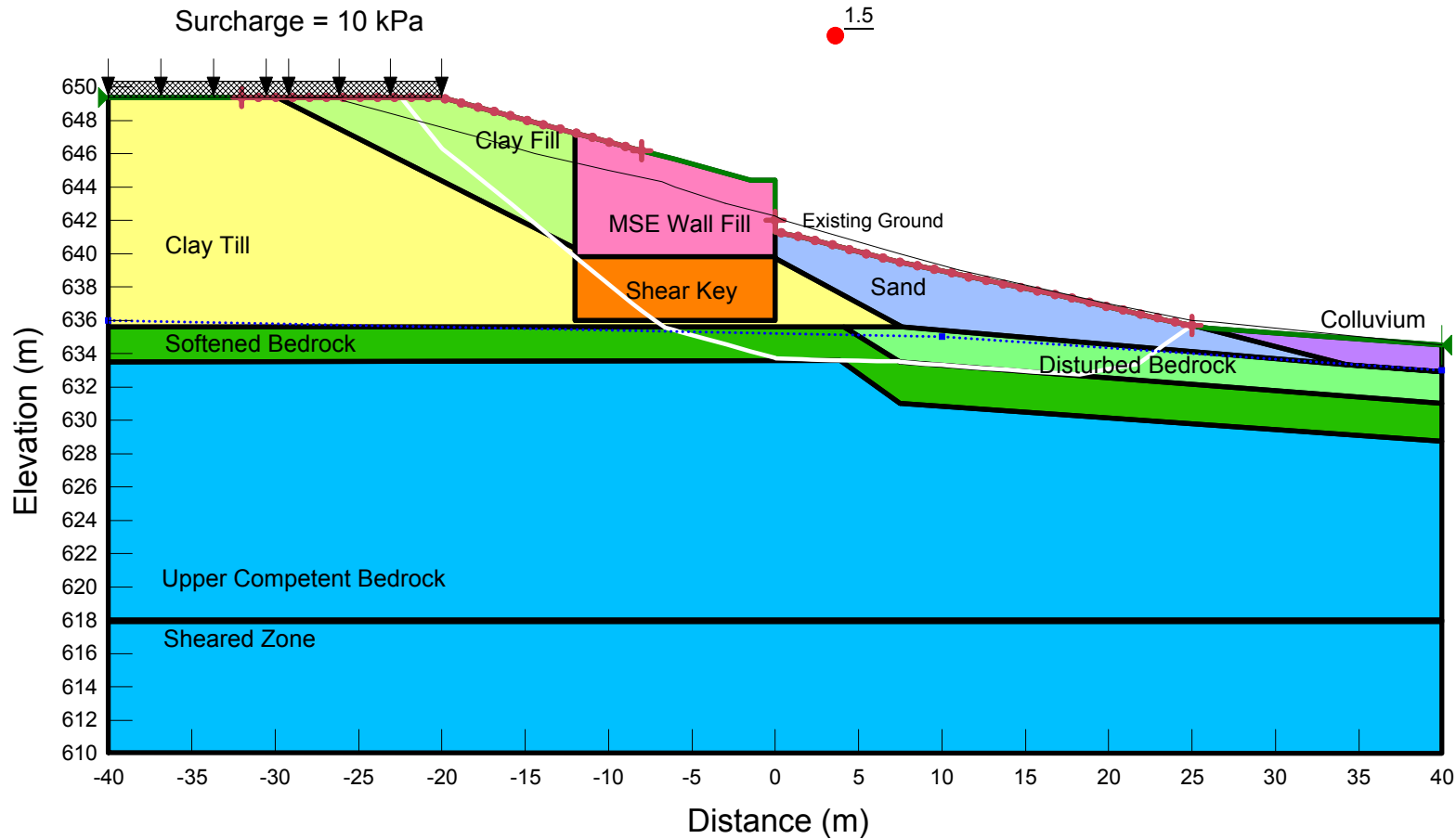

B3
 LT
 12 m Wall, base at 640 m
 12 m Shear Key, base at 636 m
 1.5 m embedment
 Increased GWT

Name: Clay Till Model: Mohr-Coulomb Unit Weight: 20 kN/m³ Cohesion: 5 kPa Phi: 28 ° Piezometric Line: 1
 Name: Clay Fill Model: Mohr-Coulomb Unit Weight: 20 kN/m³ Cohesion: 5 kPa Phi: 28 °
 Name: Disturbed Bedrock Model: Mohr-Coulomb Unit Weight: 21 kN/m³ Cohesion: 0 kPa Phi: 14 ° Piezometric Line: 1
 Name: Upper Competent Bedrock Model: Mohr-Coulomb Unit Weight: 21 kN/m³ Cohesion: 50 kPa Phi: 25 ° Piezometric Line: 1
 Name: Colluvium (Clay) Model: Mohr-Coulomb Unit Weight: 18 kN/m³ Cohesion: 0 kPa Phi: 25 ° Piezometric Line: 1
 Name: MSE Wall Fill Model: Mohr-Coulomb Unit Weight: 20 kN/m³ Cohesion: 200 kPa Phi: 30 ° Piezometric Line: 1
 Name: Softened Bedrock Model: Mohr-Coulomb Unit Weight: 21 kN/m³ Cohesion: 0 kPa Phi: 25 ° Piezometric Line: 1
 Name: Shear Key Model: Mohr-Coulomb Unit Weight: 20 kN/m³ Cohesion: 0 kPa Phi: 35 ° Piezometric Line: 1
 Name: Sand (SP-SM) Model: Mohr-Coulomb Unit Weight: 20 kN/m³ Cohesion: 0 kPa Phi: 32 ° Piezometric Line: 1
 Name: Sheared Zone Model: Mohr-Coulomb Unit Weight: 20 kN/m³ Cohesion: 0 kPa Phi: 14 ° Piezometric Line: 1

Surcharge = 10 kPa

1.5

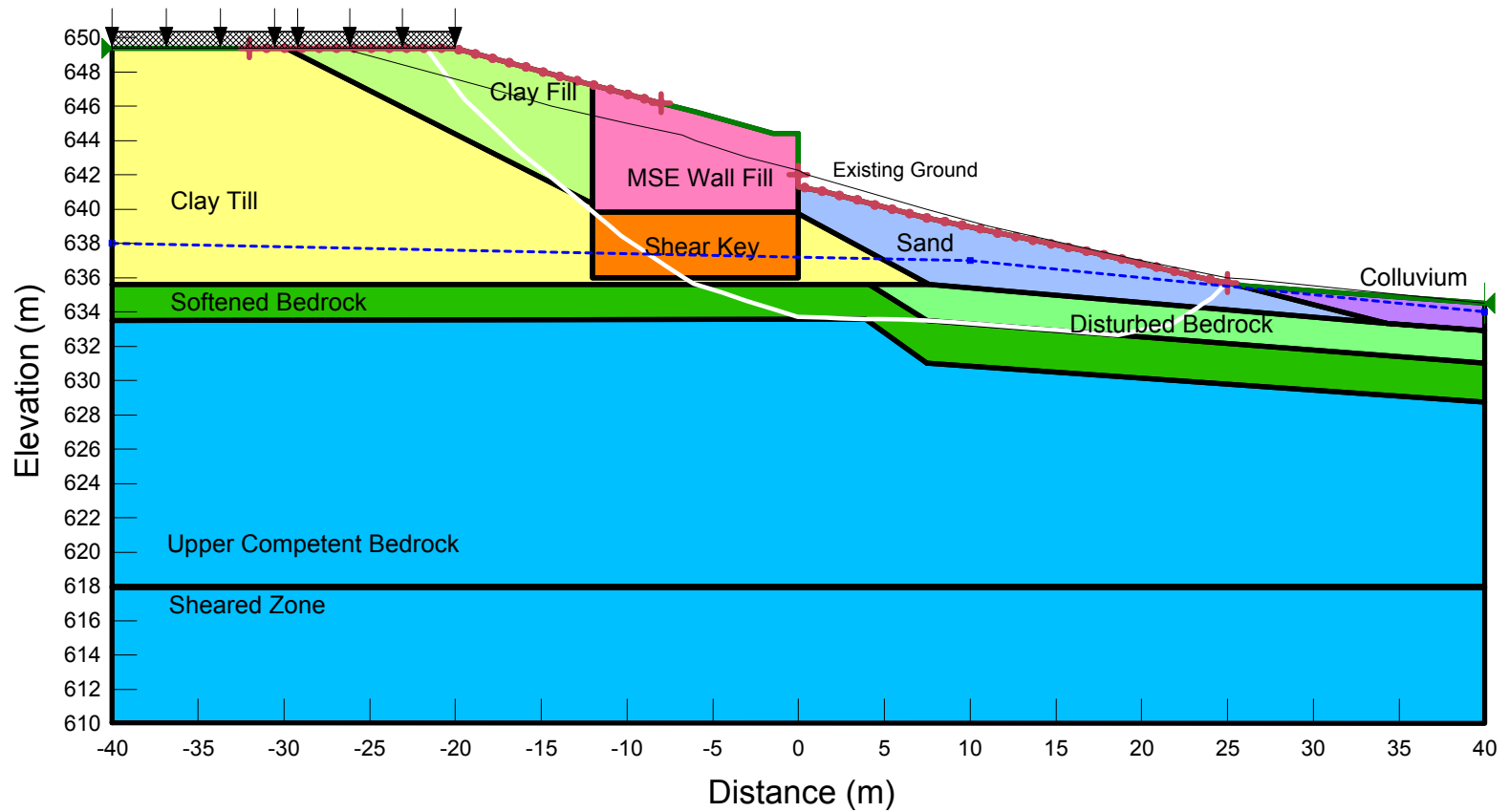

B4
 EOC
 14 m Wall
 Wall base at 635 m
 14 m Key at 632 m
 1.5 m embedment

Name: Clay Till Model: Mohr-Coulomb Unit Weight: 20 kN/m³ Cohesion: 5 kPa Phi: 28 ° Piezometric Line: 1 B-bar: 0.2 Add Weight: No
 Name: Clay Fill Model: Mohr-Coulomb Unit Weight: 20 kN/m³ Cohesion: 5 kPa Phi: 28 ° B-bar: 0.2 Add Weight: Yes
 Name: Disturbed Bedrock Model: Mohr-Coulomb Unit Weight: 21 kN/m³ Cohesion: 0 kPa Phi: 14 ° Piezometric Line: 1 B-bar: 0.4 Add Weight: No
 Name: Upper Competent Bedrock Model: Mohr-Coulomb Unit Weight: 21 kN/m³ Cohesion: 50 kPa Phi: 25 ° Piezometric Line: 1 B-bar: 0.4 Add Weight: No
 Name: Colluvium (Clay) Model: Mohr-Coulomb Unit Weight: 18 kN/m³ Cohesion: 0 kPa Phi: 25 ° Piezometric Line: 1 B-bar: 0.4 Add Weight: No
 Name: MSE Wall Fill Model: Mohr-Coulomb Unit Weight: 20 kN/m³ Cohesion: 200 kPa Phi: 30 ° Piezometric Line: 1 B-bar: 0 Add Weight: Yes
 Name: Softened Bedrock Model: Mohr-Coulomb Unit Weight: 21 kN/m³ Cohesion: 0 kPa Phi: 25 ° Piezometric Line: 1 B-bar: 0.4 Add Weight: No
 Name: Shear Key Model: Mohr-Coulomb Unit Weight: 20 kN/m³ Cohesion: 0 kPa Phi: 35 ° Piezometric Line: 1 B-bar: 0 Add Weight: No
 Name: Sheared Zone Model: Mohr-Coulomb Unit Weight: 20 kN/m³ Cohesion: 0 kPa Phi: 14 ° Piezometric Line: 1 B-bar: 0 Add Weight: No

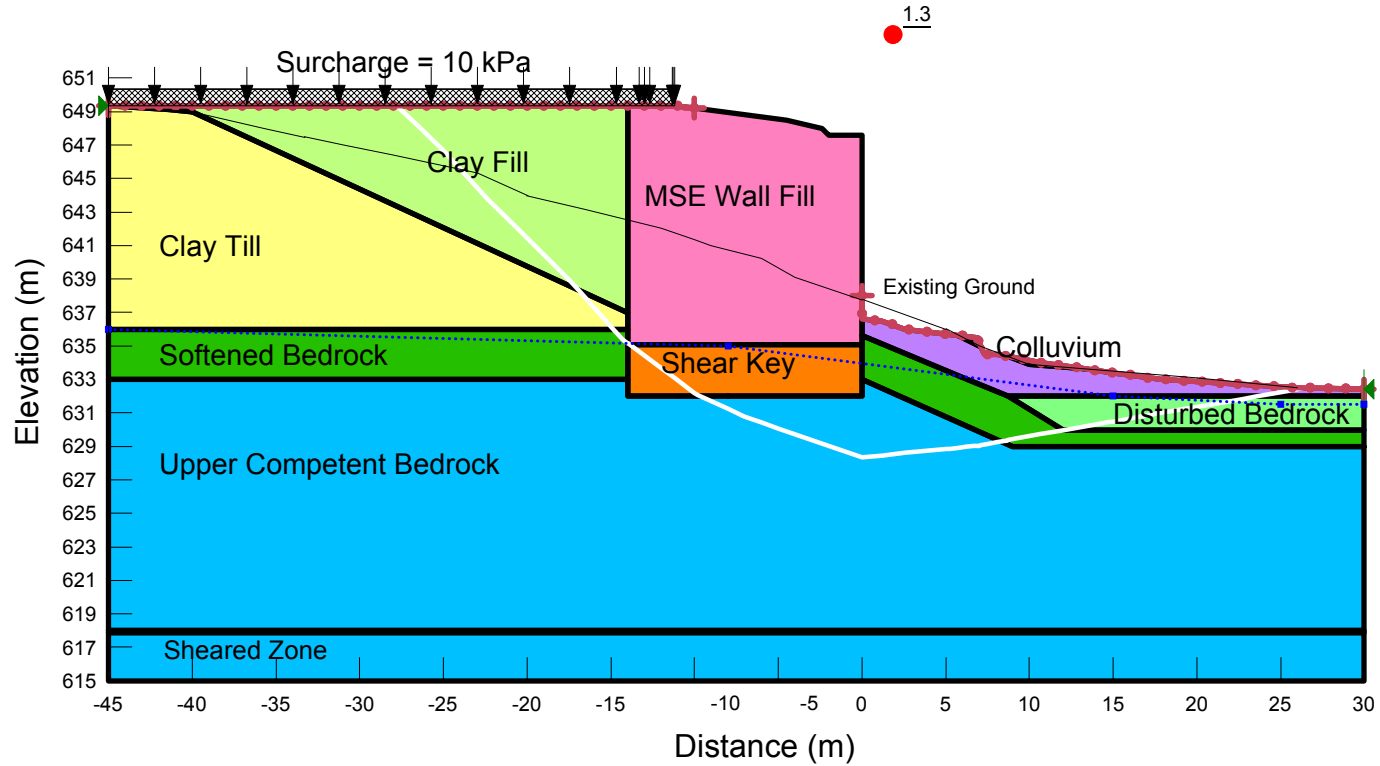

B4
14 m Wall at 635 m
14 m Key at 632 m
1.5 m embedment
Increased GWT

Name: Clay Till	Model: Mohr-Coulomb	Unit Weight: 20 kN/m ³	Cohesion': 5 kPa	Phi': 28 °	Piezometric Line: 1
Name: Clay Fill	Model: Mohr-Coulomb	Unit Weight: 20 kN/m ³	Cohesion': 5 kPa	Phi': 28 °	
Name: Disturbed Bedrock	Model: Mohr-Coulomb	Unit Weight: 21 kN/m ³	Cohesion': 0 kPa	Phi': 14 °	Piezometric Line: 1
Name: Upper Competent Bedrock	Model: Mohr-Coulomb	Unit Weight: 21 kN/m ³	Cohesion': 50 kPa	Phi': 25 °	Piezometric Line: 1
Name: Colluvium (Clay)	Model: Mohr-Coulomb	Unit Weight: 18 kN/m ³	Cohesion': 0 kPa	Phi': 25 °	Piezometric Line: 1
Name: MSE Wall Fill	Model: Mohr-Coulomb	Unit Weight: 20 kN/m ³	Cohesion': 200 kPa	Phi': 30 °	Piezometric Line: 1
Name: Softened Bedrock	Model: Mohr-Coulomb	Unit Weight: 21 kN/m ³	Cohesion': 0 kPa	Phi': 25 °	Piezometric Line: 1
Name: Shear Key	Model: Mohr-Coulomb	Unit Weight: 20 kN/m ³	Cohesion': 0 kPa	Phi': 35 °	Piezometric Line: 1
Name: Sheared Zone	Model: Mohr-Coulomb	Unit Weight: 20 kN/m ³	Cohesion': 0 kPa	Phi': 14 °	Piezometric Line: 1

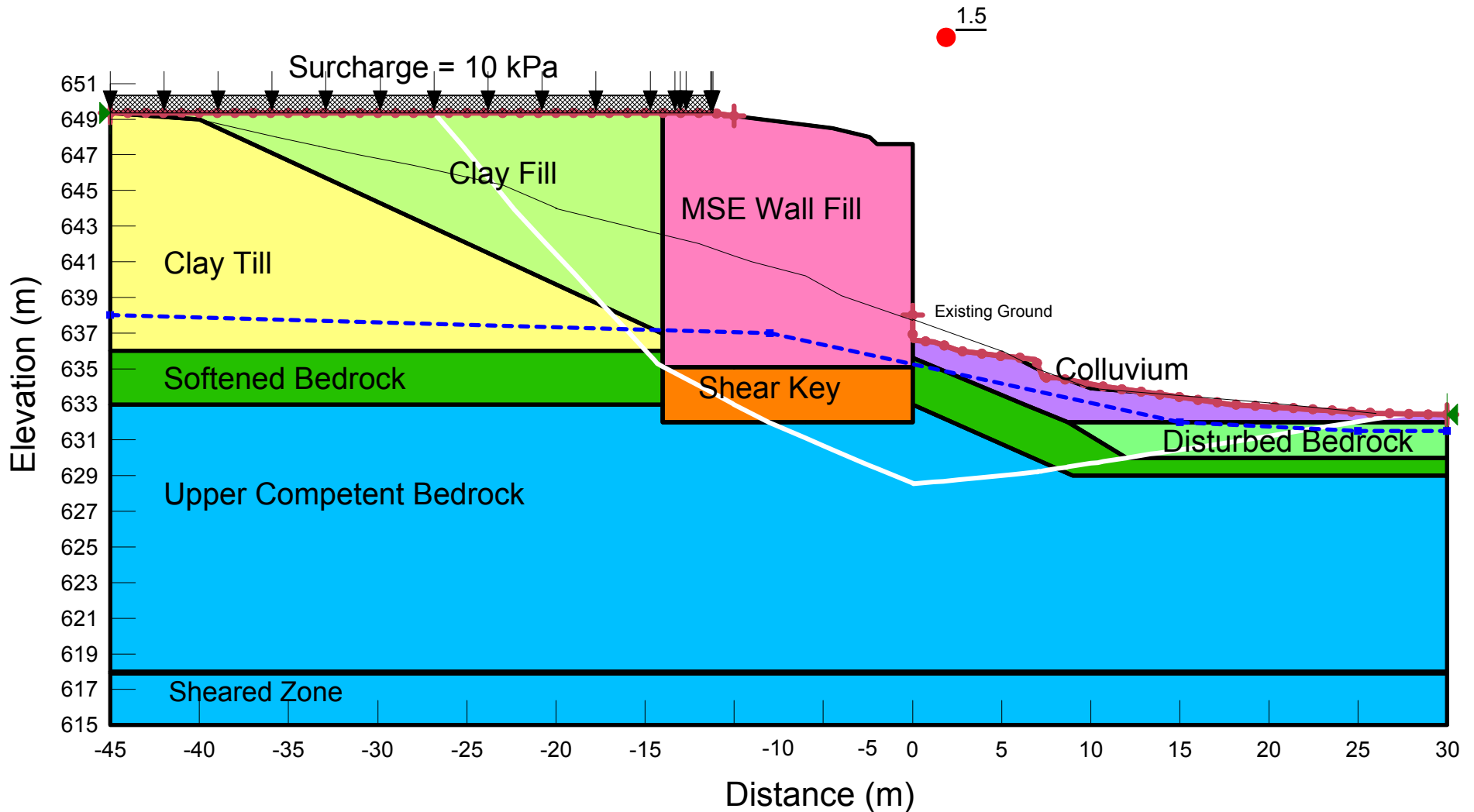

Color	Name	Model	Unit Weight (kN/m ³)	Cohesion (kPa)	Phi (°)	Piezometric Line	B-bar	Add Weight
Yellow	Clay Till	Mohr-Coulomb	20	5	28	1	0.2	No
Light Green	Clay Fill	Mohr-Coulomb	20	5	28	1	0.2	Yes
Dark Green	Softened Bedrock	Mohr-Coulomb	21	0	25	1	0.4	No
Blue	Upper Competent Bedrock	Mohr-Coulomb	21	50	25	1	0.4	No
Pink	MSE Wall Fill	Mohr-Coulomb	20	200	30	1	0	Yes
Orange	Shear Key	Mohr-Coulomb	20	0	35	1	0	No



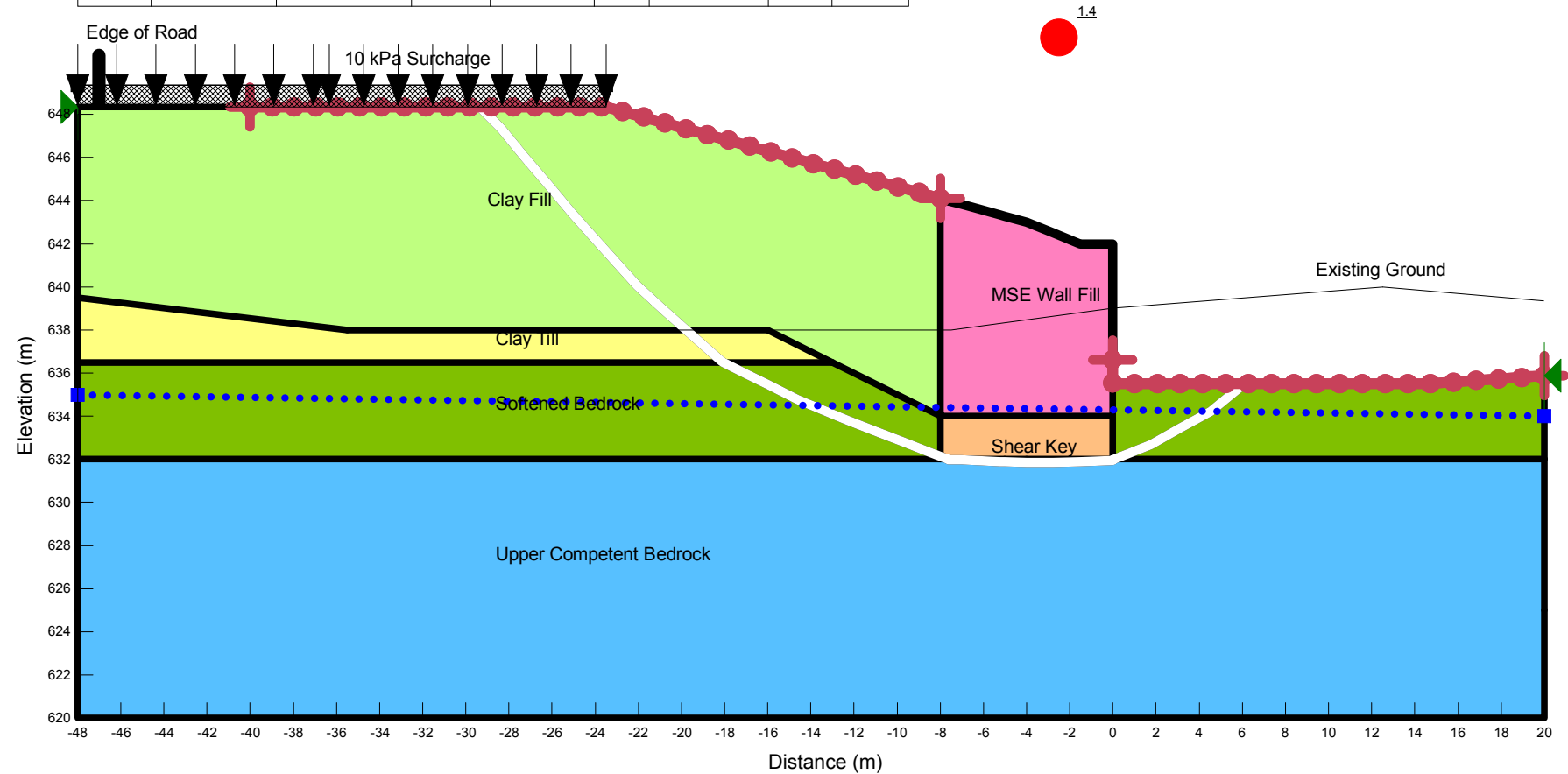



C1
EOC
8 m wall
Wall base at 634 m
8 m Key at 632 m
1.5 m embedment

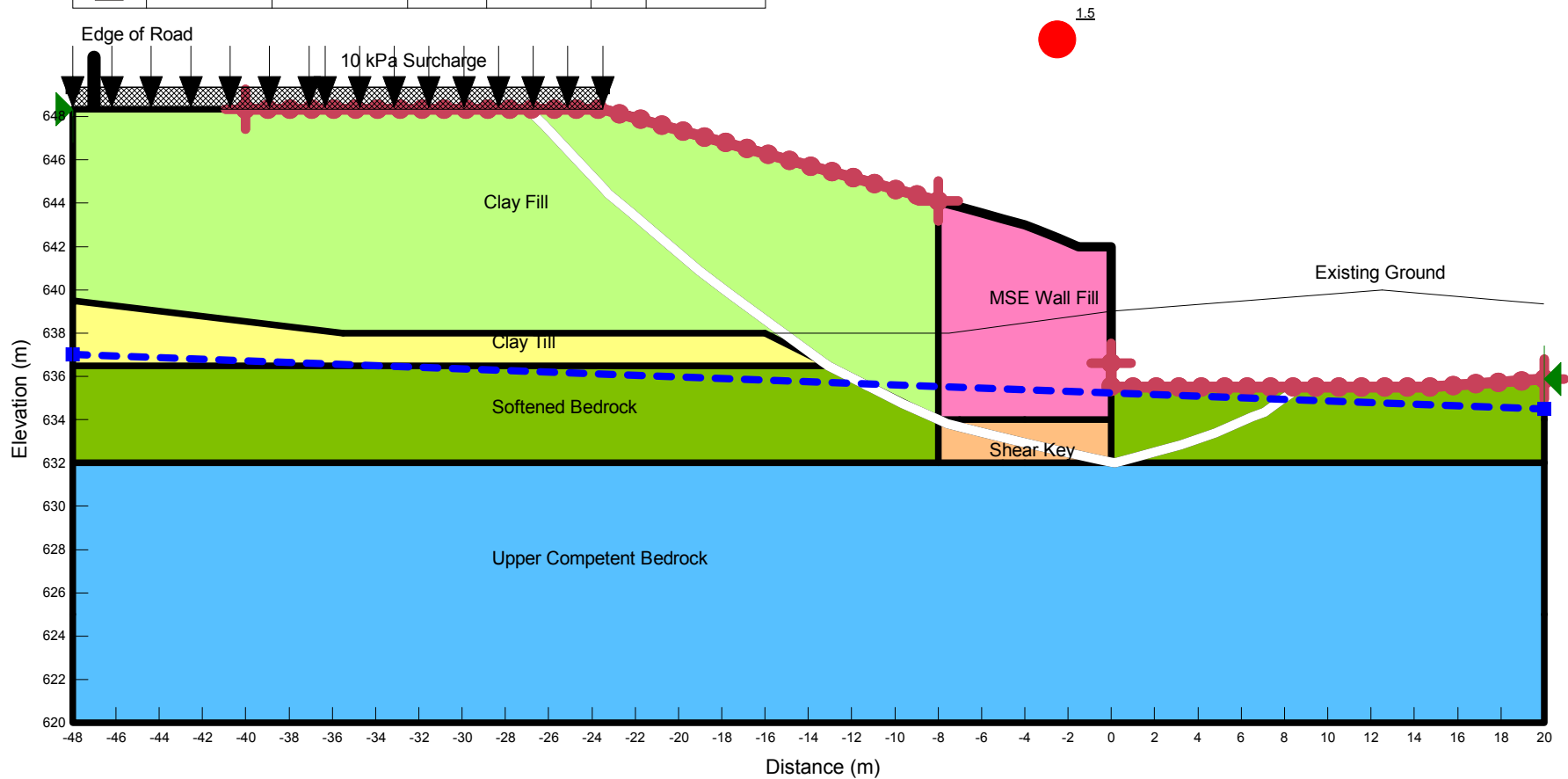

Color	Name	Model	Unit Weight (kN/m ³)	Cohesion (kPa)	Phi (°)	Piezometric Line
Yellow	Clay Till	Mohr-Coulomb	20	5	28	1
Light Green	Clay Fill	Mohr-Coulomb	20	5	28	1
Dark Green	Softened Bedrock	Mohr-Coulomb	21	0	25	1
Blue	Upper Competent Bedrock	Mohr-Coulomb	21	50	25	1
Pink	MSE Wall Fill	Mohr-Coulomb	20	200	30	1
Orange	Shear Key	Mohr-Coulomb	20	0	35	1







C1
 LT
 8 m wall
 Wall base at 634 m
 8 m Key at 632 m
 1.5 m embedment
 Increased GWT

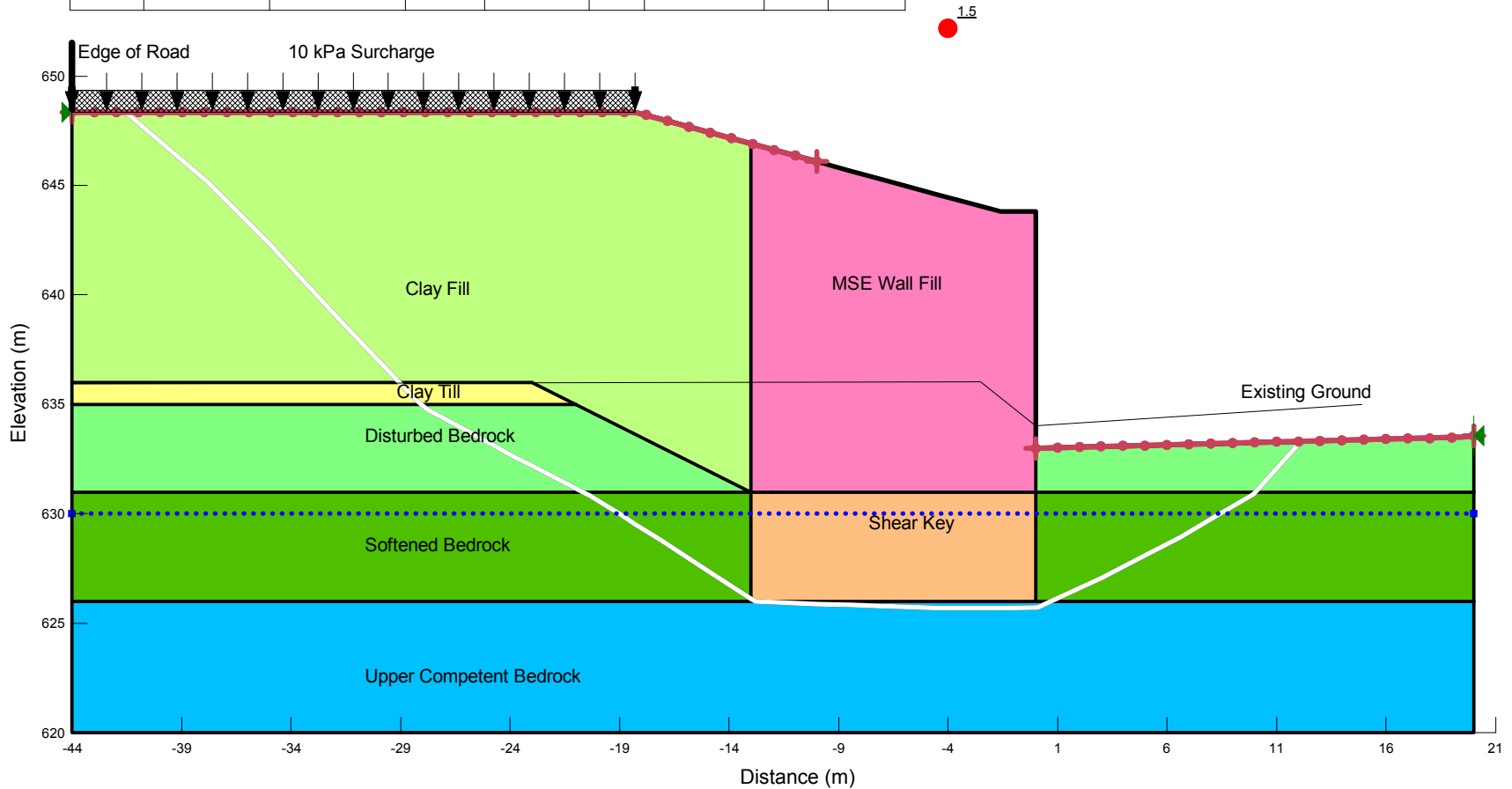

Color	Name	Model	Unit Weight (kN/m ³)	Cohesion' (kPa)	Phi' (°)	Piezometric Line	B-bar	Add Weight
	Clay Till	Mohr-Coulomb	20	5	28	1	0.2	No
	Clay Fill	Mohr-Coulomb	20	5	28	1	0.2	Yes
	Disturbed Bedrock	Mohr-Coulomb	21	0	14	1	0.4	No
	Upper Competent Bedrock	Mohr-Coulomb	21	50	25	1	0.4	No
	MSE Wall Fill	Mohr-Coulomb	20	200	30	1	0	Yes
	Shear Key	Mohr-Coulomb	20	0	35	1	0	No
	Softened Bedrock	Mohr-Coulomb	21	0	25	1	0.4	No

C2
 EOC
 13 m wide wall
 Wall base at 631 m
 13 m Key at 626 m
 2 m embedment



Color	Name	Model	Unit Weight (kN/m ³)	Cohesion' (kPa)	Phi' (°)	Piezometric Line
	Clay Till	Mohr-Coulomb	20	5	28	1
	Clay Fill	Mohr-Coulomb	20	5	28	1
	Disturbed Bedrock	Mohr-Coulomb	21	0	14	1
	Upper Competent Bedrock	Mohr-Coulomb	21	50	25	1
	MSE Wall Fill	Mohr-Coulomb	20	200	30	1
	Shear Key	Mohr-Coulomb	20	0	35	1
	Softened Bedrock	Mohr-Coulomb	21	0	25	1

C2
 LT
 13 m wide wall
 Wall base at 631 m
 13 m Key at 626 m
 2 m embedment
 GWT Increased

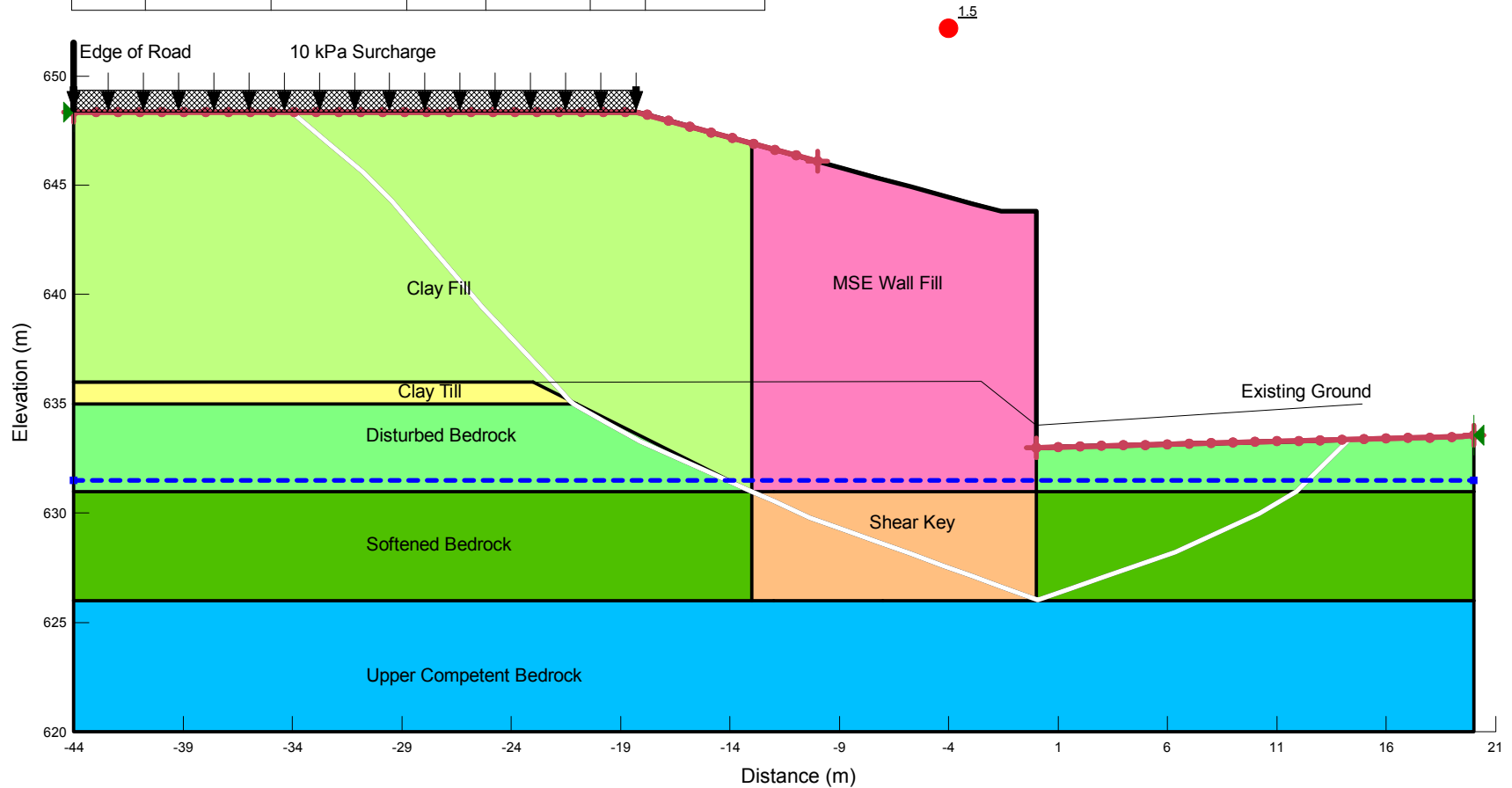

Color	Name	Model	Unit Weight (kN/m ³)	Cohesion' (kPa)	Phi' (°)	Piezometric Line	B-bar	Add Weight
Light Green	Clay Fill	Mohr-Coulomb	20	5	28	1	0.2	Yes
Light Green	Disturbed Bedrock	Mohr-Coulomb	21	0	14	1	0.4	No
Dark Green	Softened Bedrock	Mohr-Coulomb	21	0	25	1	0.4	No
Light Blue	Upper Competent Bedrock	Mohr-Coulomb	21	50	25	1	0.4	No
Purple	Colluvium (Clay)	Mohr-Coulomb	18	0	25	1	0	No
Pink	MSE Wall Fill	Mohr-Coulomb	20	200	30	1	0	Yes
Orange	Shear Key	Mohr-Coulomb	20	0	35	1	0	No

C3
EOC
14 m wall at 630 m
14 m Shear Key at 626 m
1.8 m embedment

1.4

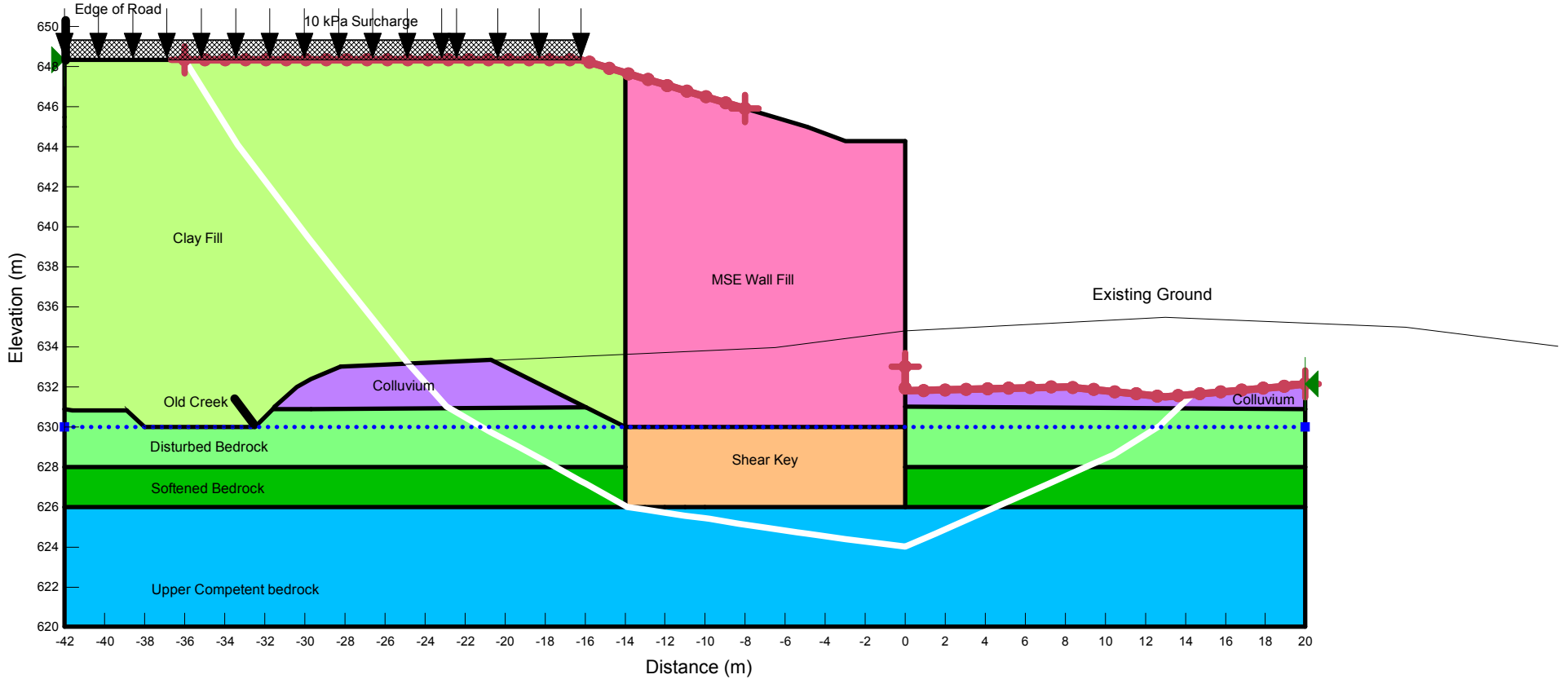
Color	Name	Model	Unit Weight (kN/m³)	Cohesion' (kPa)	Phi' (°)	Piezometric Line
Light Green	Clay Fill	Mohr-Coulomb	20	5	28	1
Light Green	Disturbed Bedrock	Mohr-Coulomb	21	0	14	1
Dark Green	Softened Bedrock	Mohr-Coulomb	21	0	25	1
Light Blue	Upper Competent Bedrock	Mohr-Coulomb	21	50	25	1
Purple	Colluvium (Clay)	Mohr-Coulomb	18	0	25	1
Pink	MSE Wall Fill	Mohr-Coulomb	20	200	30	1
Orange	Shear Key	Mohr-Coulomb	20	0	35	1

C3
 LT
 14 m wall at 630 m
 14 m Shear Key at 626 m
 1.8 m embedment
 Increased GWT

1.5

Color	Name	Model	Unit Weight (kN/m ³)	Cohesion' (kPa)	Phi' (°)	Piezometric Line	B-bar	Add Weight
Yellow	Clay Till	Mohr-Coulomb	20	5	28	1	0.2	No
Light Green	Clay Fill	Mohr-Coulomb	20	5	28		0.2	Yes
Light Green	Disturbed Bedrock	Mohr-Coulomb	21	0	20	1	0.4	No
Blue	Upper Competent Bedrock	Mohr-Coulomb	21	50	25	1	0.4	No
Pink	MSE Wall Fill	Mohr-Coulomb	20	200	30	1	0	Yes
Dark Green	Softened Bedrock	Mohr-Coulomb	21	0	25	1	0.4	No
Orange	Shear Key	Mohr-Coulomb	20	0	35	1	0	No
Blue	Sheared Zone	Mohr-Coulomb	21	0	14	1	0.4	No

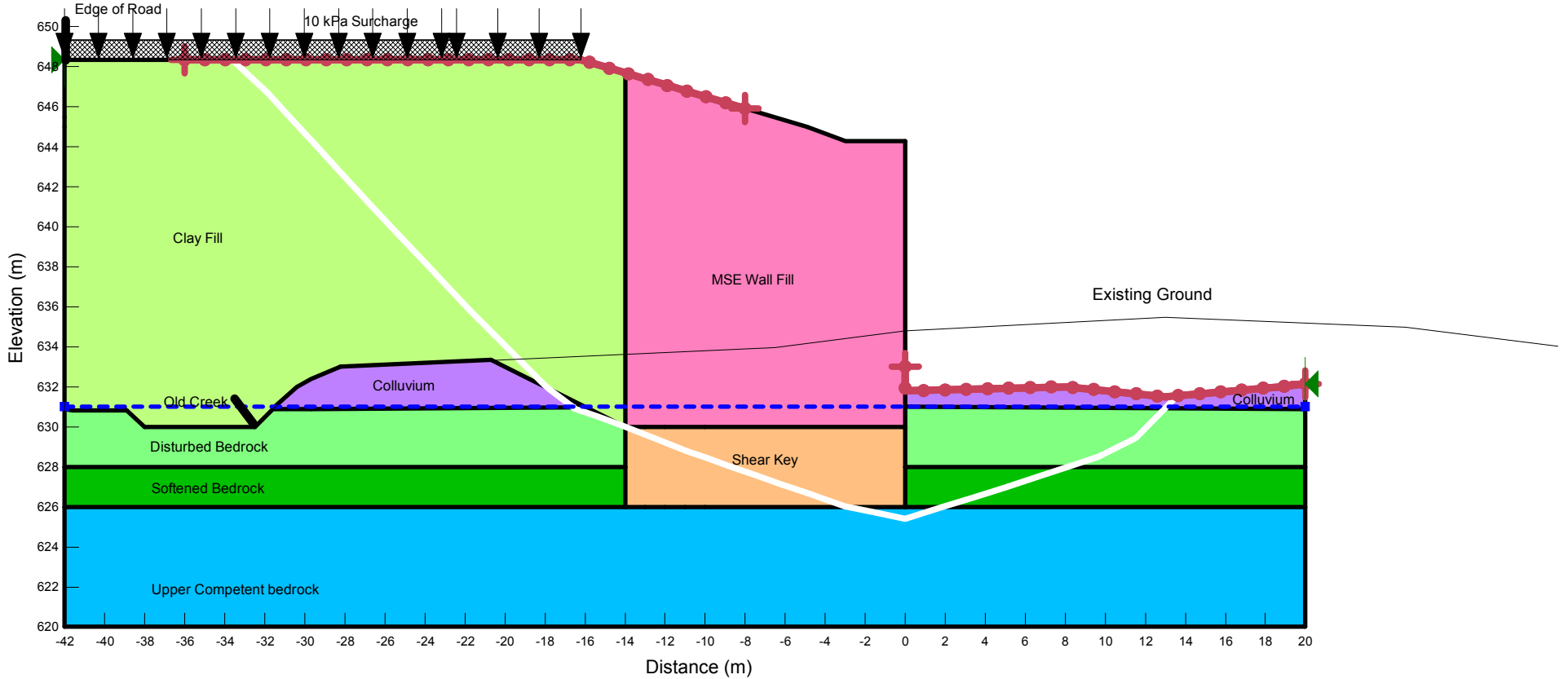
D1
EOC
14 m wall at 631m
13 m shear key at 626 m
2 m embedment

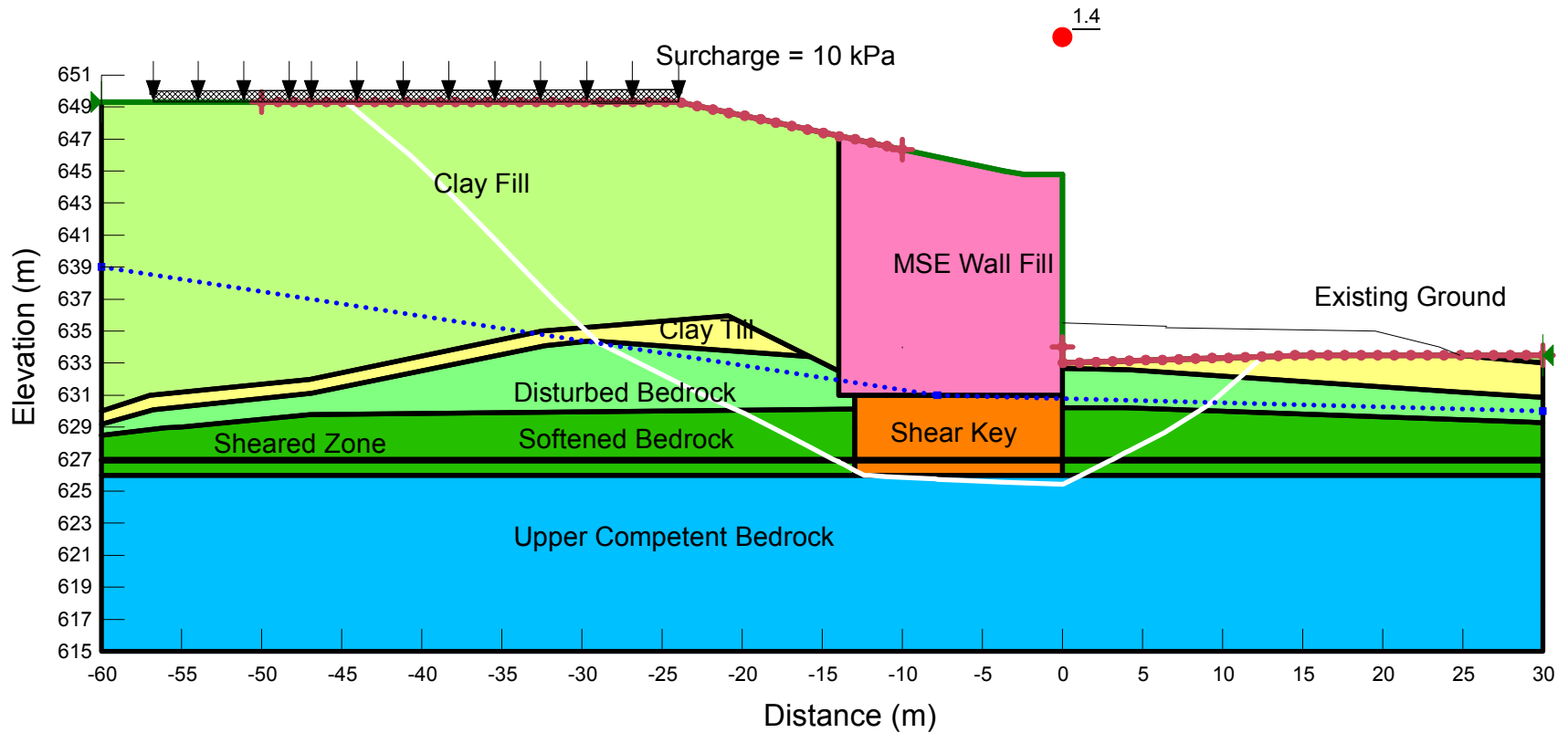

Color	Name	Model	Unit Weight (kN/m ³)	Cohesion' (kPa)	Phi' (°)	Piezometric Line
Yellow	Clay Till	Mohr-Coulomb	20	5	28	1
Light Green	Clay Fill	Mohr-Coulomb	20	5	28	
Green	Disturbed Bedrock	Mohr-Coulomb	21	0	20	1
Blue	Upper Competent Bedrock	Mohr-Coulomb	21	50	25	1
Pink	MSE Wall Fill	Mohr-Coulomb	20	200	30	1
Dark Green	Softened Bedrock	Mohr-Coulomb	21	0	25	1
Orange	Shear Key	Mohr-Coulomb	20	0	35	1
Dark Blue	Sheared Zone	Mohr-Coulomb	21	0	14	1

D1
 LT
 14 m wall at 631m
 13 m shear key at 626 m
 2 m embedment
 Increased GWT

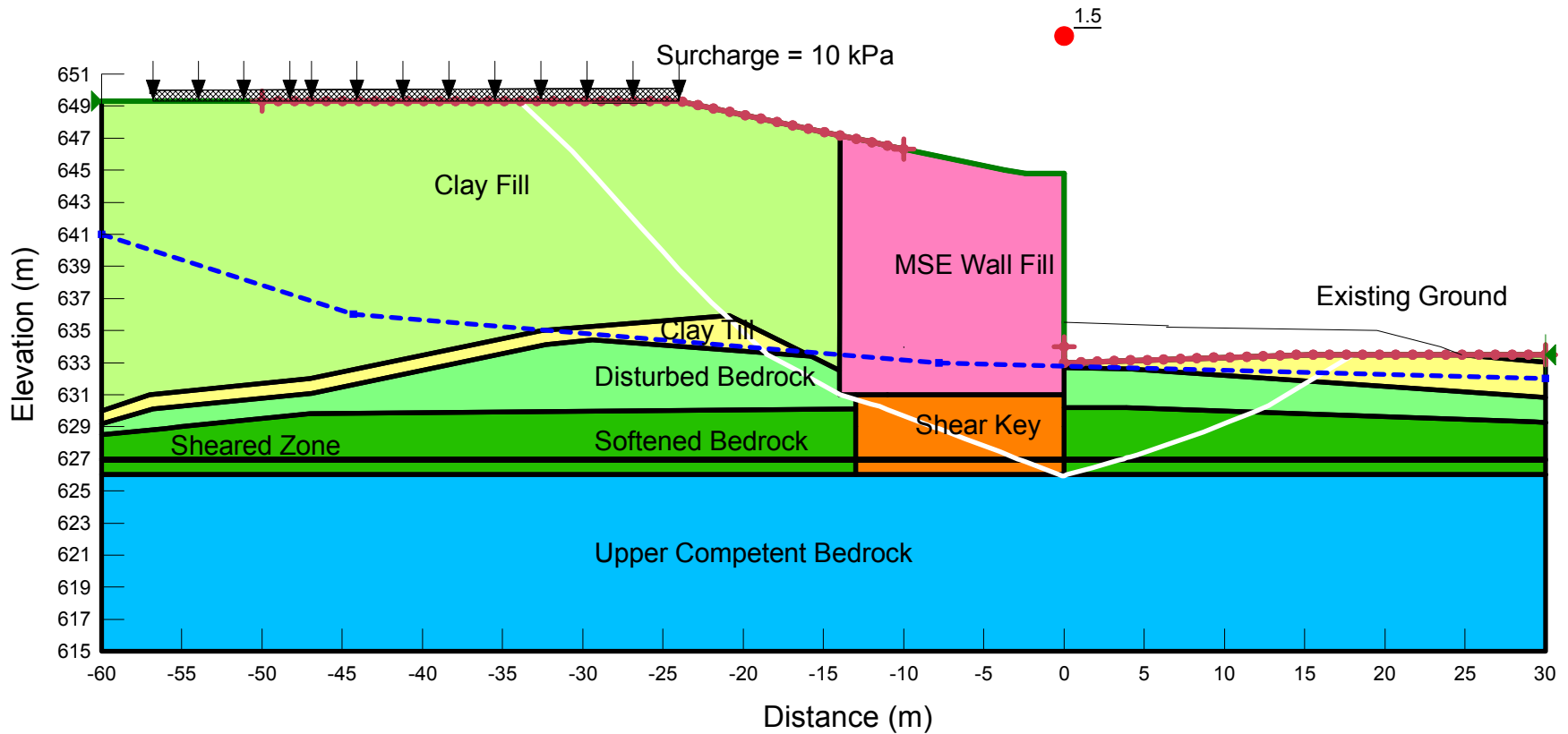

Color	Name	Model	Unit Weight (kN/m ³)	Cohesion' (kPa)	Phi' (°)	Piezometric Line	B-bar	Add Weight
Yellow	Clay Till	Mohr-Coulomb	20	5	28	1	0.2	No
Light Green	Clay Fill	Mohr-Coulomb	20	5	28		0.2	Yes
Blue	Upper Competent Bedrock	Mohr-Coulomb	21	50	25	1	0.4	No
Pink	MSE Wall Fill	Mohr-Coulomb	20	200	30	1	0	Yes
Green	Softened Bedrock	Mohr-Coulomb	21	0	25	1	0.4	No
Orange	Shear Key	Mohr-Coulomb	20	0	35	1	0	No
Blue	Sheared Zone	Mohr-Coulomb	21	0	14	1	0.4	No

D2
 EOC
 6 m MSE Wall at 636 m
 6 m Key at 633
 1.8 m embedment

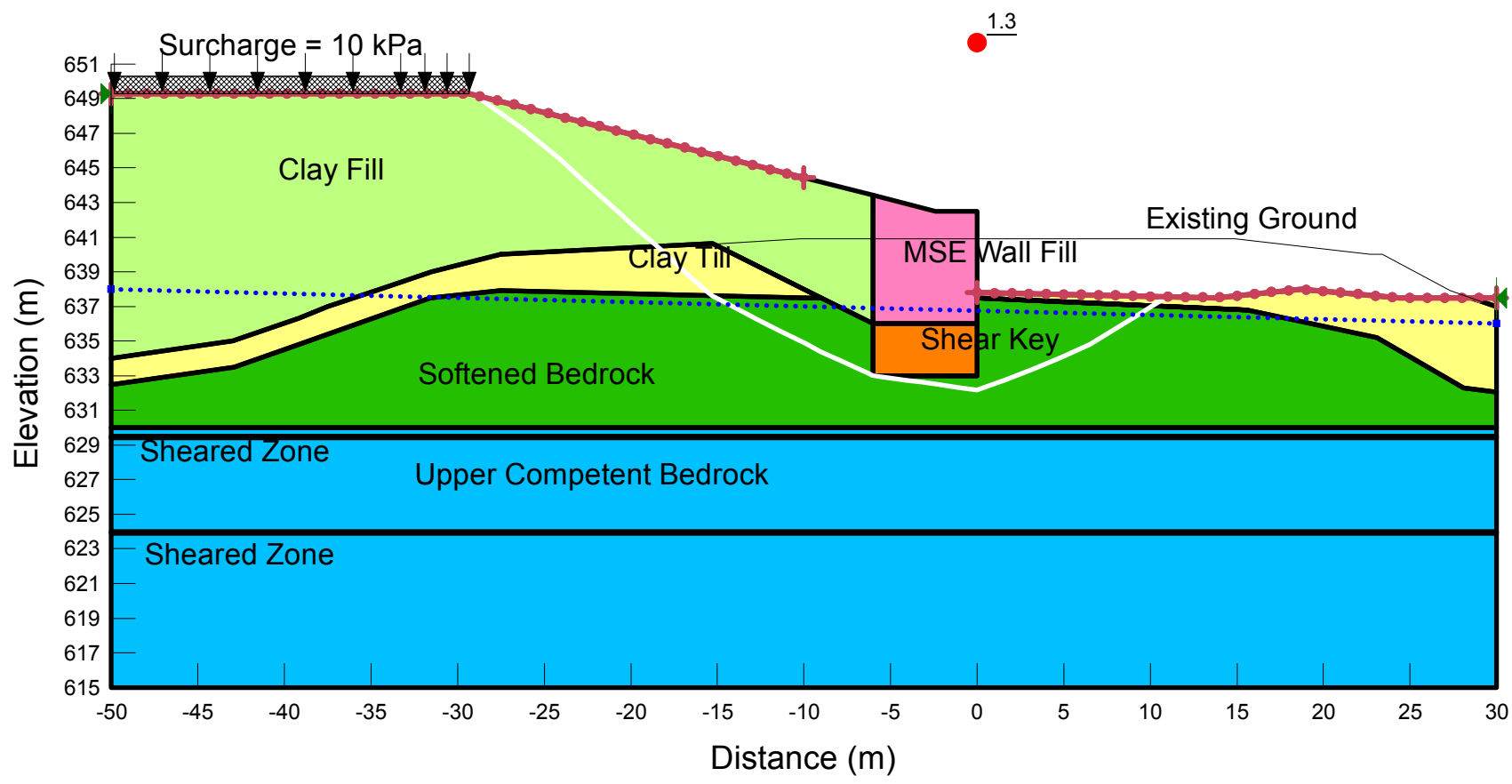

Color	Name	Model	Unit Weight (kN/m ³)	Cohesion' (kPa)	Phi' (°)	Piezometric Line
Yellow	Clay Till	Mohr-Coulomb	20	5	28	1
Light Green	Clay Fill	Mohr-Coulomb	20	5	28	
Blue	Upper Competent Bedrock	Mohr-Coulomb	21	50	25	1
Pink	MSE Wall Fill	Mohr-Coulomb	20	200	30	1
Green	Softened Bedrock	Mohr-Coulomb	21	0	25	1
Orange	Shear Key	Mohr-Coulomb	20	0	35	1
Dark Blue	Sheared Zone	Mohr-Coulomb	21	0	14	1

D2
 LT
 6 m MSE Wall at 636 m
 6 m Key at 633
 1.8 m embedment
 Increased GWT

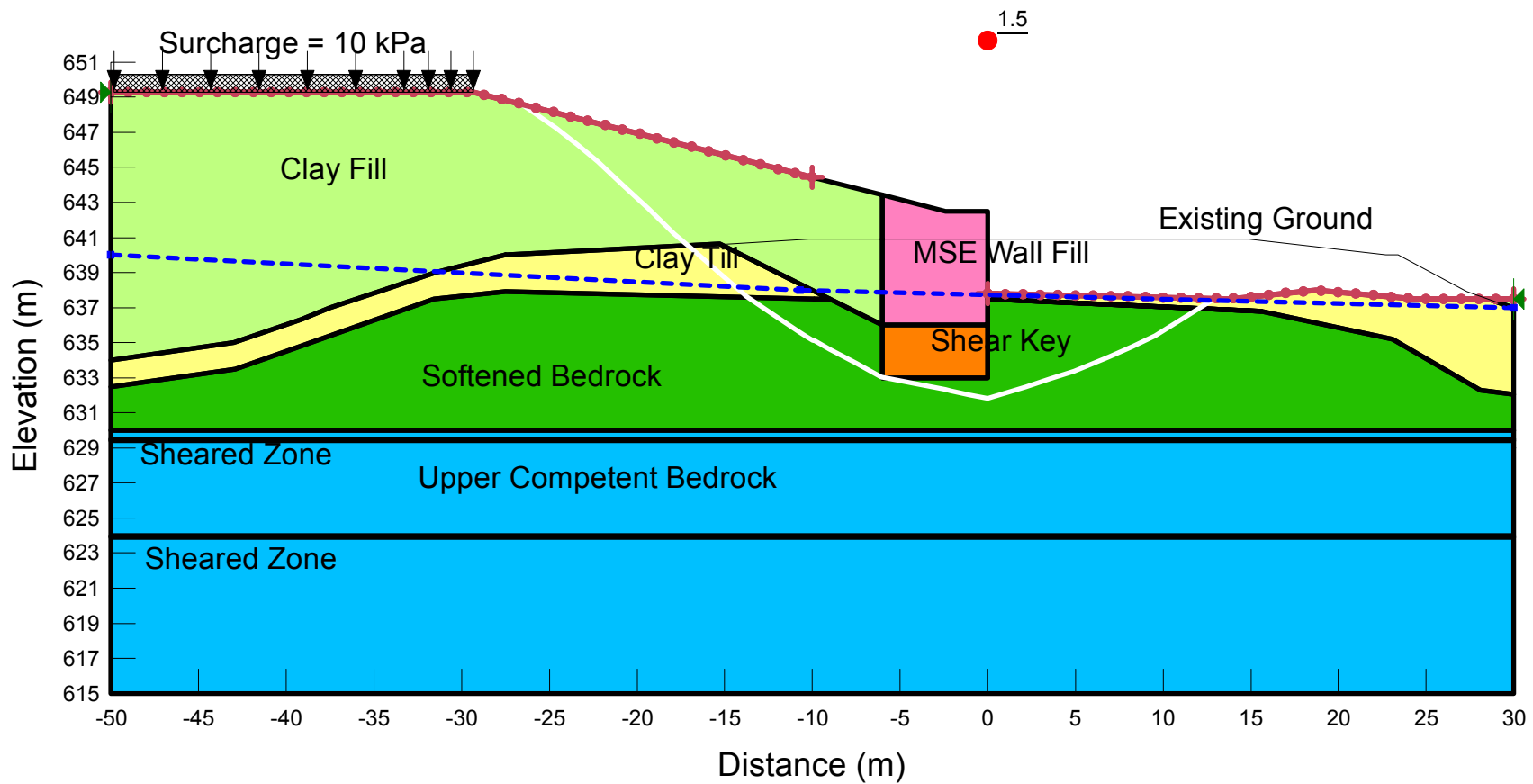

Color	Name	Model	Unit Weight (kN/m ³)	Cohesion' (kPa)	Phi' (°)	Piezometric Line	B-bar	Add Weight
Yellow	Clay Till	Mohr-Coulomb	20	5	28	1	0.2	No
Light Green	Clay Fill	Mohr-Coulomb	20	5	28	1	0.2	Yes
Light Green	Disturbed Bedrock	Mohr-Coulomb	21	0	14	1	0.4	No
Dark Green	Softened Bedrock	Mohr-Coulomb	21	0	25	1	0.4	No
Light Blue	Upper Competent Bedrock	Mohr-Coulomb	21	50	25	1	0.4	No
Pink	MSE Wall Fill	Mohr-Coulomb	20	200	30	1	0	Yes
Orange	Shear Key	Mohr-Coulomb	20	0	35	1	0	No
Blue	Sheared Zone	Mohr-Coulomb	21	0	14	1	0.4	No

D3
EOC
14 m Wall at 633 m
14 m Key at 628.9 m
(Shear Key through sheared zone)

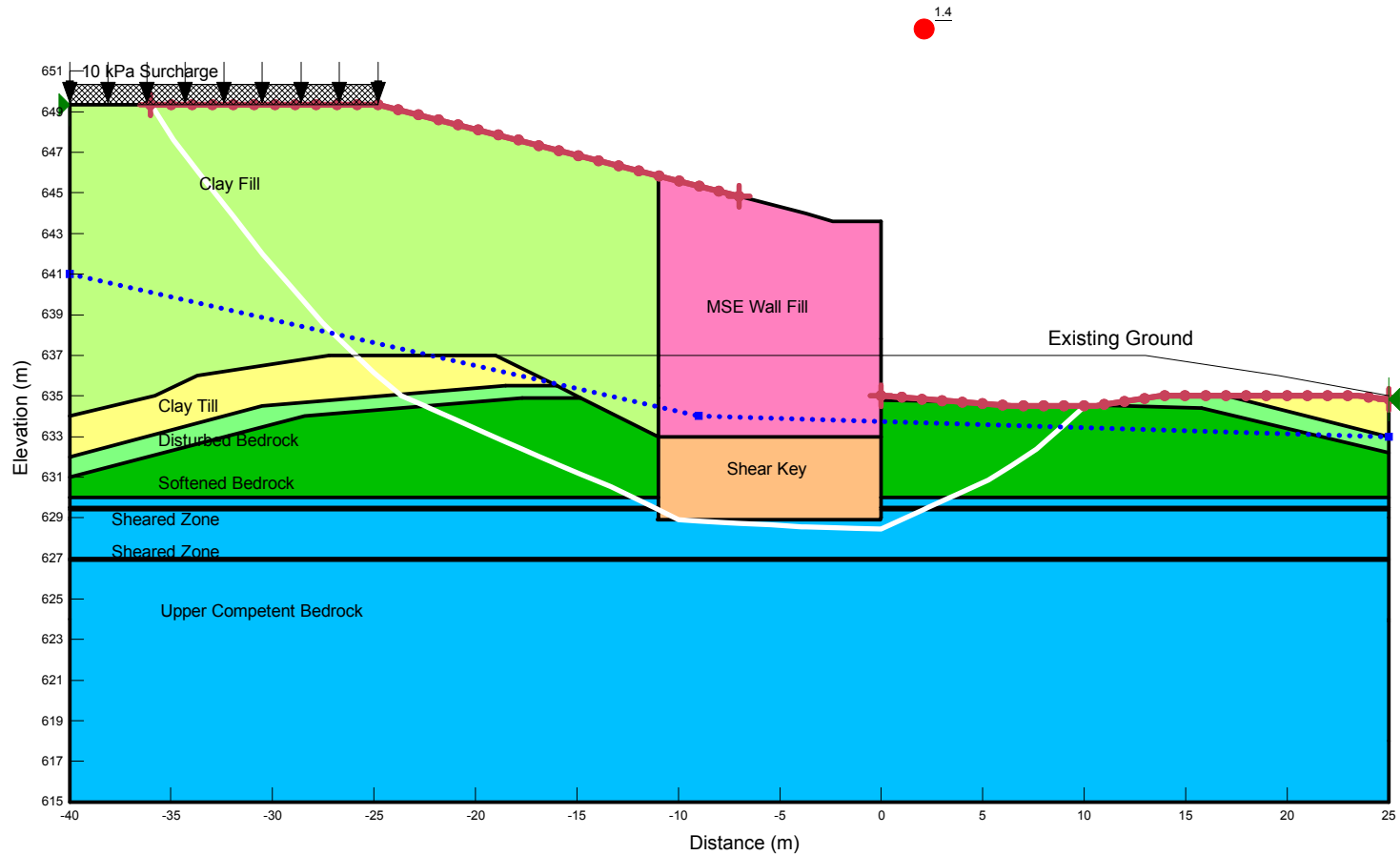

Color	Name	Model	Unit Weight (kN/m ³)	Cohesion' (kPa)	Phi' (°)	Piezometric Line
Yellow	Clay Till	Mohr-Coulomb	20	5	28	1
Light Green	Clay Fill	Mohr-Coulomb	20	5	28	1
Light Green	Disturbed Bedrock	Mohr-Coulomb	21	0	14	1
Dark Green	Softened Bedrock	Mohr-Coulomb	21	0	25	1
Light Blue	Upper Competent Bedrock	Mohr-Coulomb	21	50	25	1
Pink	MSE Wall Fill	Mohr-Coulomb	20	200	30	1
Orange	Shear Key	Mohr-Coulomb	20	0	35	1
Blue	Sheared Zone	Mohr-Coulomb	21	0	14	1

D3
 LT
 14 m Wall at 633 m
 14 m Key at 628.9 m
 (Shear Key through sheared zone)
 2 m embedment
 Increased GWT

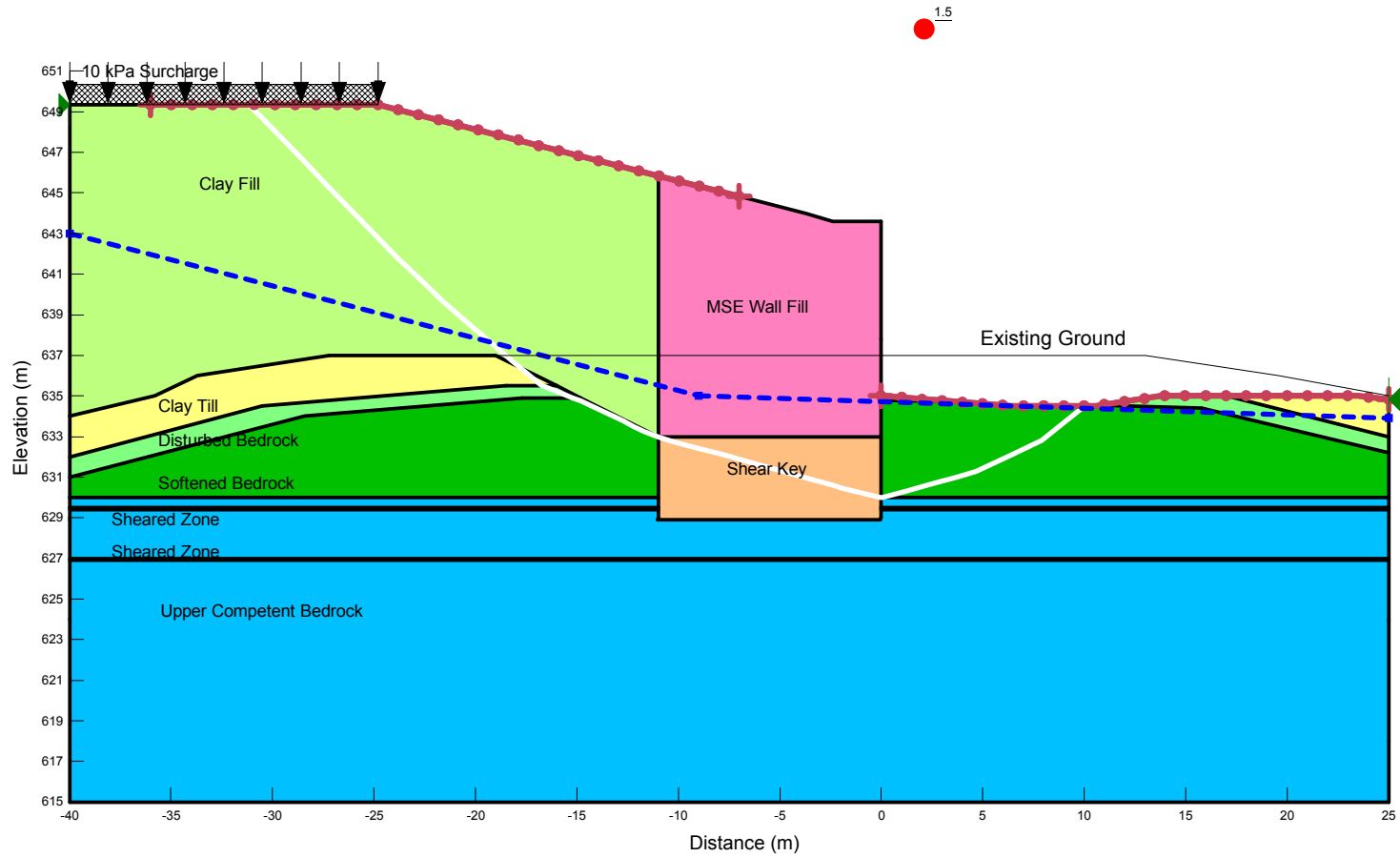

Color	Name	Model	Unit Weight (kN/m ³)	Cohesion' (kPa)	Phi' (°)	Piezometric Line	B-bar	Add Weight
Yellow	Clay Till	Mohr-Coulomb	20	5	28	1	0.2	No
Light Green	Clay Fill	Mohr-Coulomb	20	5	28	1	0.2	Yes
Green	Disturbed Bedrock	Mohr-Coulomb	21	0	14	1	0.4	No
Grey	Competent Bedrock Infinite Strength	Bedrock (Impenetrable)				1	0.4	No
Dark Green	Softened Bedrock	Mohr-Coulomb	21	0	25	1	0.4	No
Blue	Upper Competent Bedrock	Mohr-Coulomb	21	50	25	1	0.4	No
Purple	Colluvium (Clay)	Mohr-Coulomb	18	0	25	1	0.4	No
Pink	MSE Wall Fill	Mohr-Coulomb	20	200	30	1	0	Yes
Orange	Shear Key	Mohr-Coulomb	20	0	35	1	0	No
Dark Blue	Sheared Zone	Mohr-Coulomb	20	0	14	1	0	No
Magenta	Alluvial Deposit	Mohr-Coulomb	18	0	25	1	0	No
Cyan	Intermediate Bedrock	Mohr-Coulomb	21	25	25	1	0.4	No

A1
EOC
10 m Wall at 636 m
10 m Key at 634 m
1.5 m Embedment

3 Piles
Shear Force = 500 kN
Shear Reduction Factor = 0.7
Spacing = 3.5 m

1.47

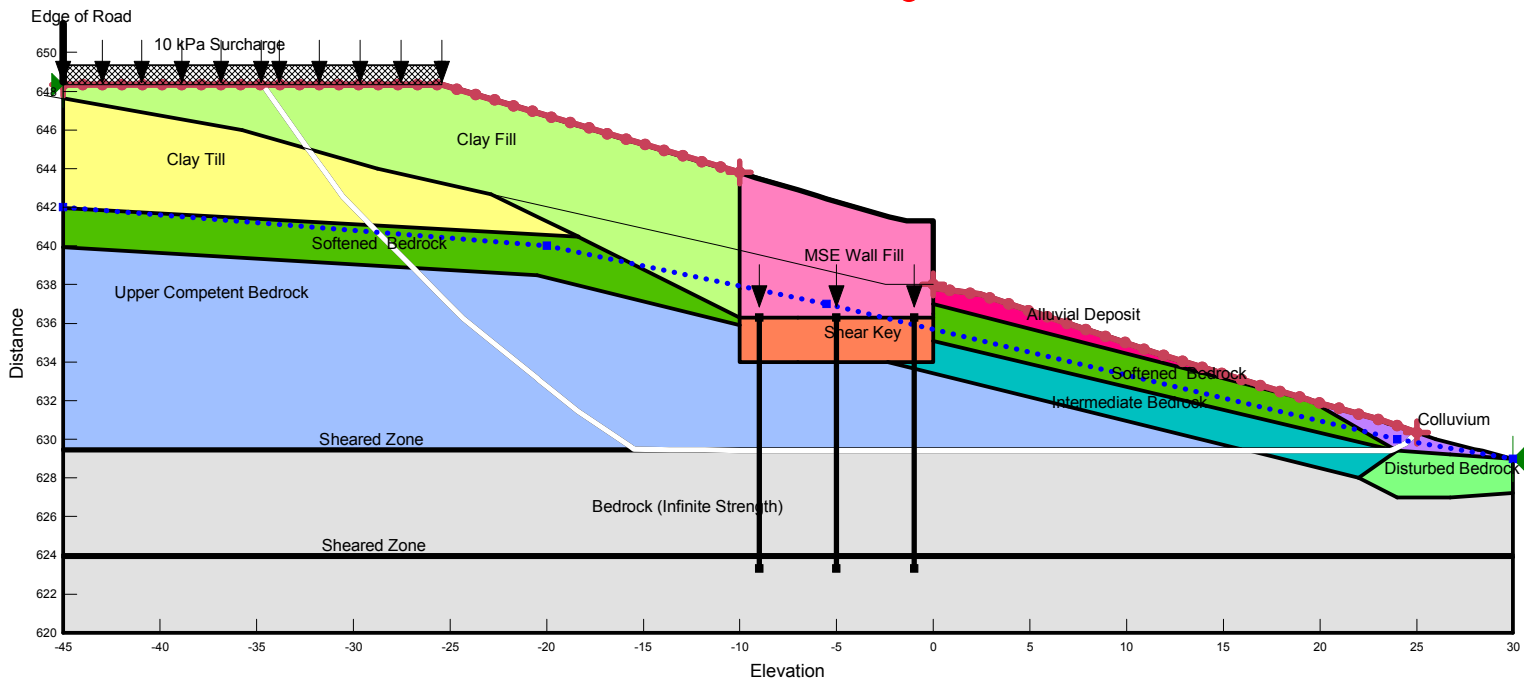

Color	Name	Model	Unit Weight (kN/m ³)	Cohesion' (kPa)	Phi' (°)	Piezometric Line
Yellow	Clay Till	Mohr-Coulomb	20	5	28	1
Light Green	Clay Fill	Mohr-Coulomb	20	5	28	1
Green	Disturbed Bedrock	Mohr-Coulomb	21	0	14	1
Grey	Competent Bedrock Infinite Strength	Bedrock (Impenetrable)				1
Dark Green	Softened Bedrock	Mohr-Coulomb	21	0	25	1
Blue	Upper Competent Bedrock	Mohr-Coulomb	21	50	25	1
Purple	Colluvium (Clay)	Mohr-Coulomb	18	0	25	1
Pink	MSE Wall Fill	Mohr-Coulomb	20	200	30	1
Orange	Shear Key	Mohr-Coulomb	20	0	35	1
Dark Blue	Sheared Zone	Mohr-Coulomb	20	0	14	1
Magenta	Alluvial Deposit	Mohr-Coulomb	18	0	25	1
Cyan	Intermediate Bedrock	Mohr-Coulomb	21	25	25	1

A1
 LT
 10 m Wall at 636 m
 10 m Key at 634 m
 1.5 m Embedment
 Increased GWT

3 Piles
 Shear Force = 500 kN
 Shear Reduction Factor = 0.7
 Spacing = 3.5 m

1.53

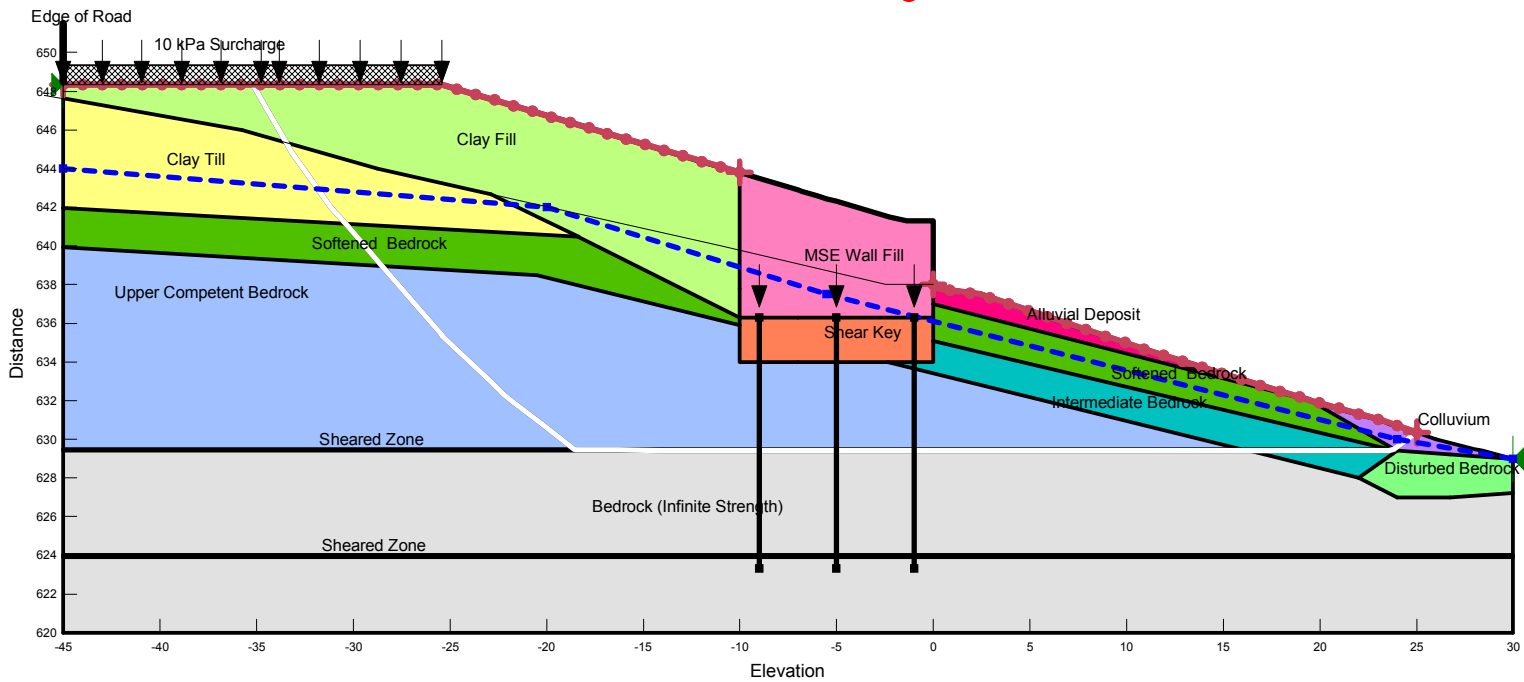

GEOTECHNICAL INVESTIGATION REPORT

February 24, 2017

Appendix F

LPILE Outputs



Lateral Deflection vs Lateral Load (Fixed Head)

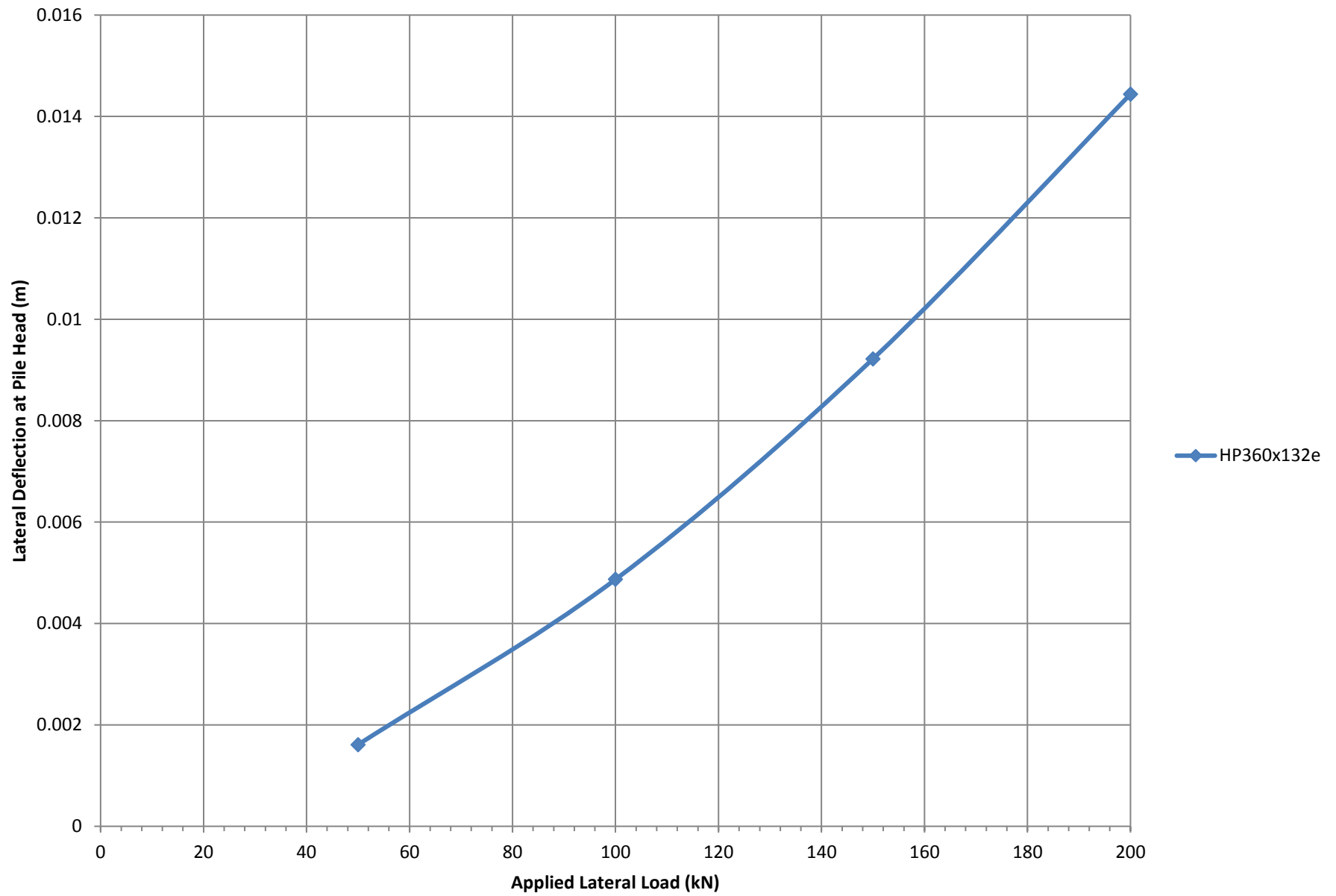

Maximum Bending Moment vs Lateral Load (Fixed Head)

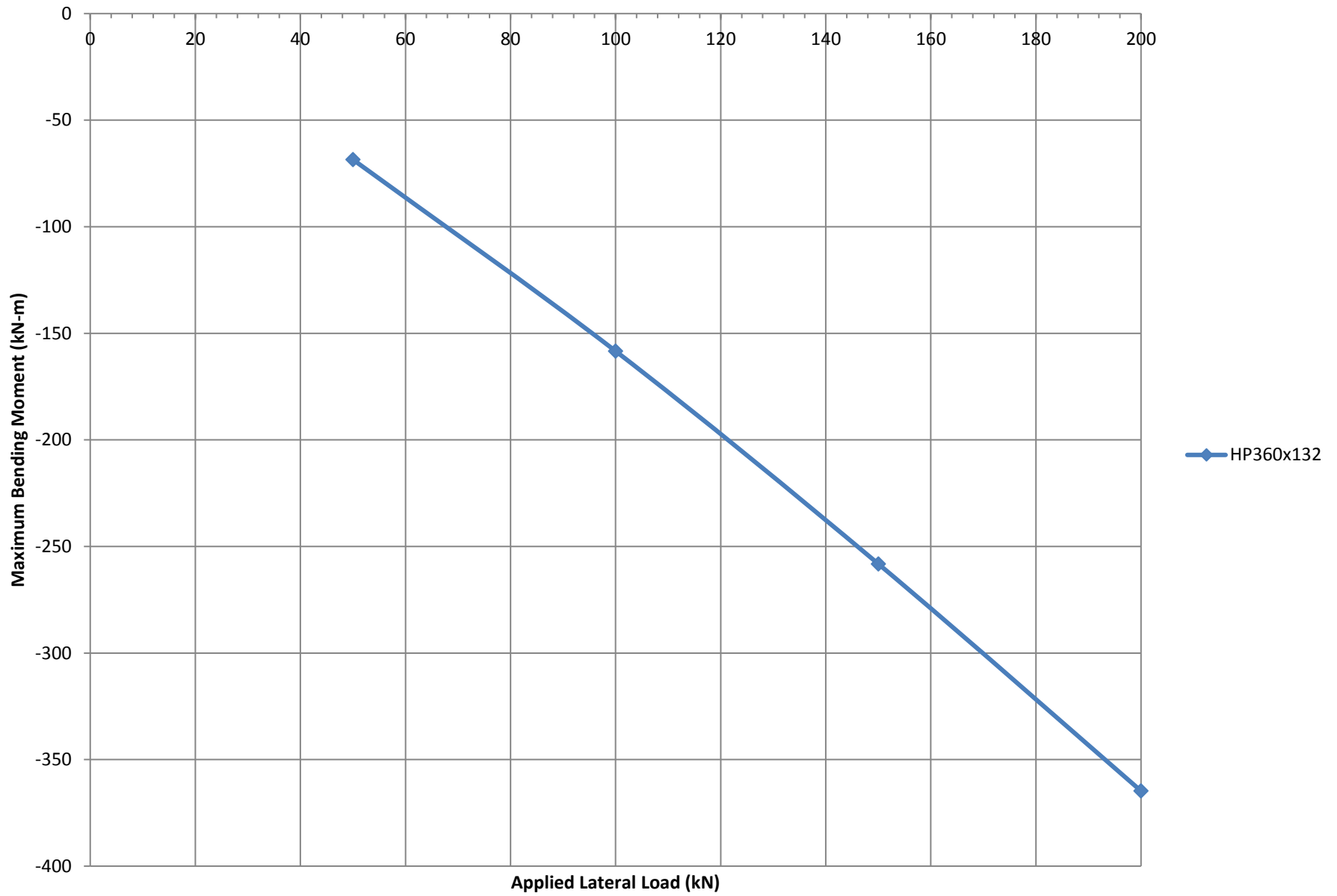

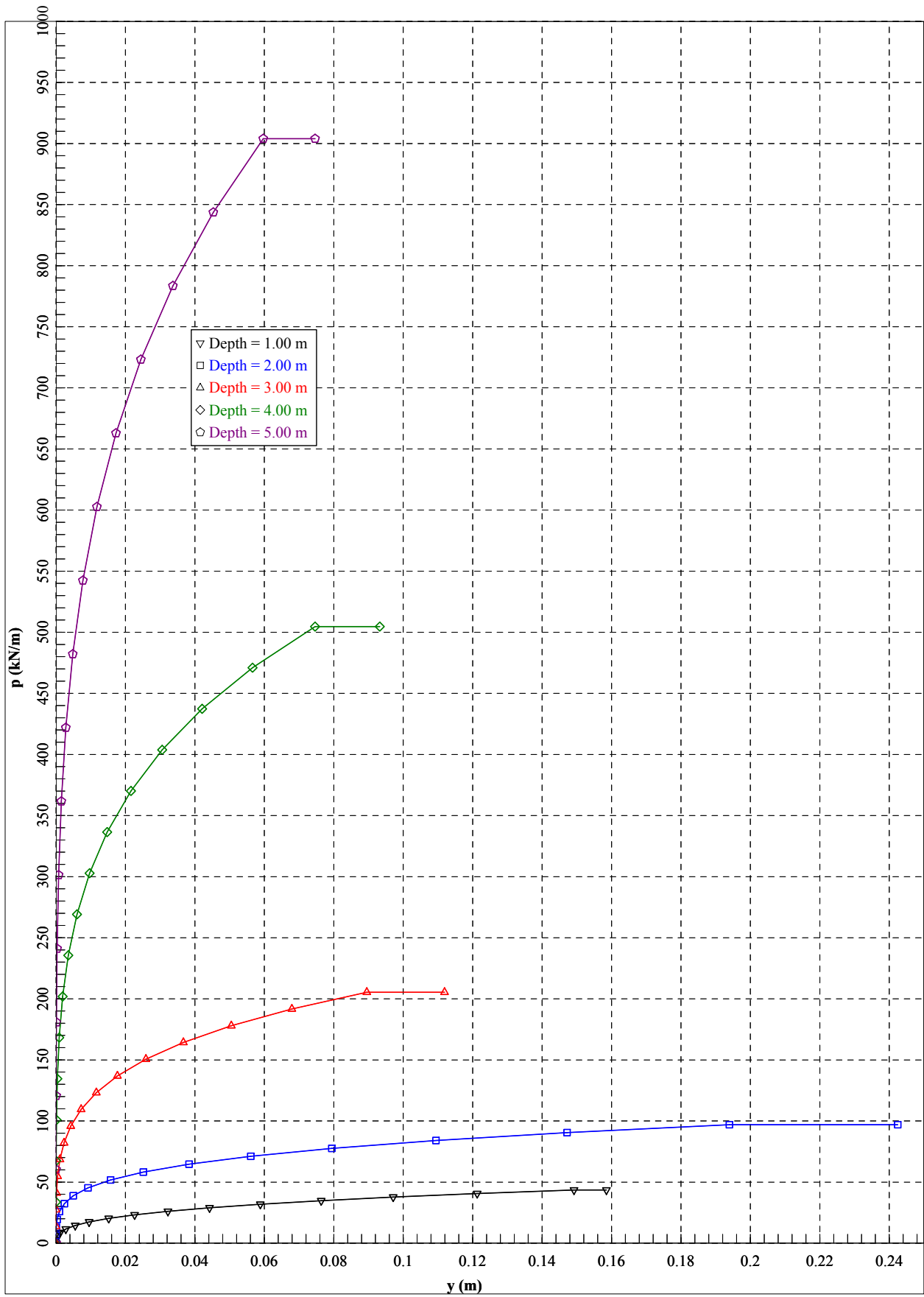

Lateral Pile Deflection vs Depth
Lateral Pile Deflection (meters)

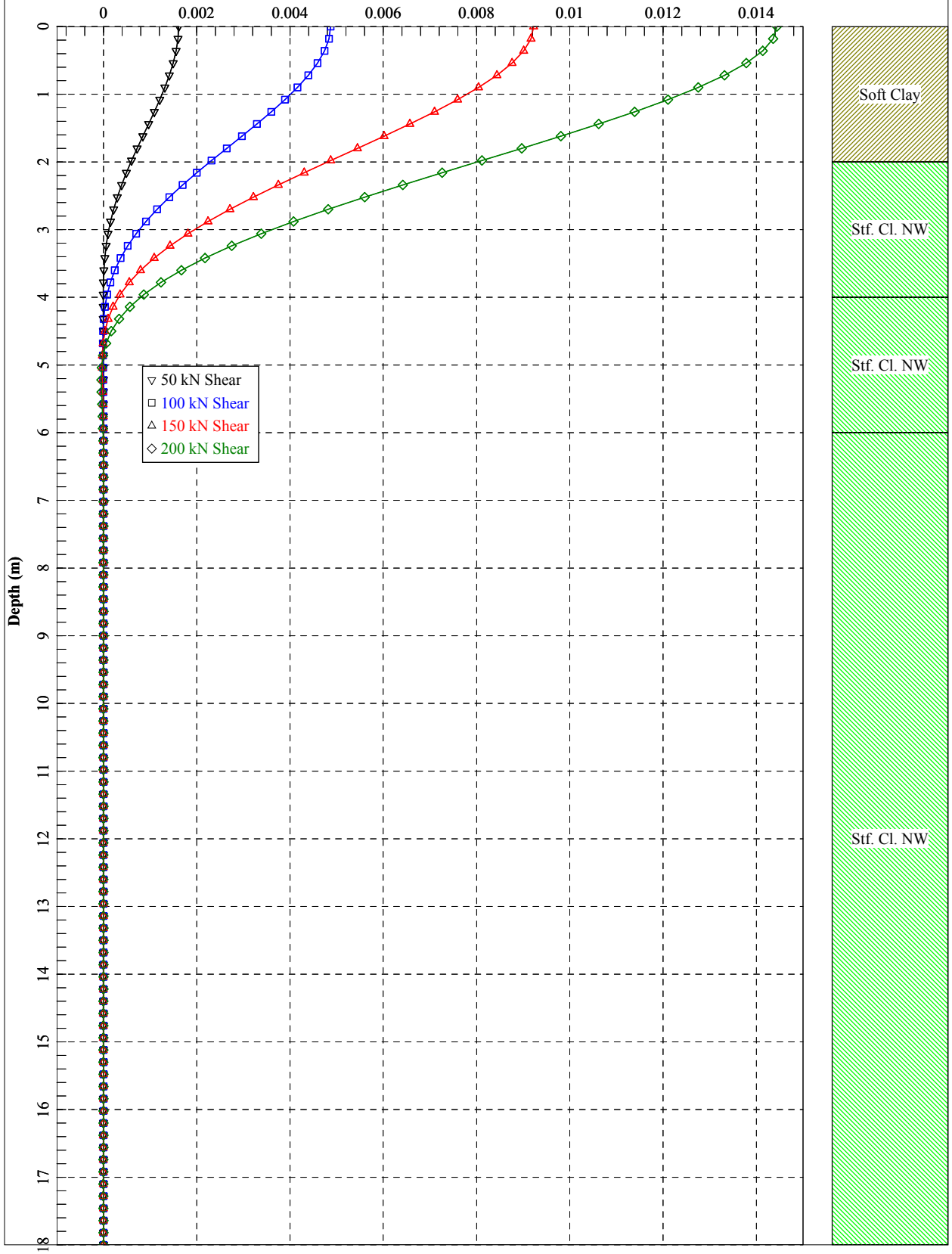

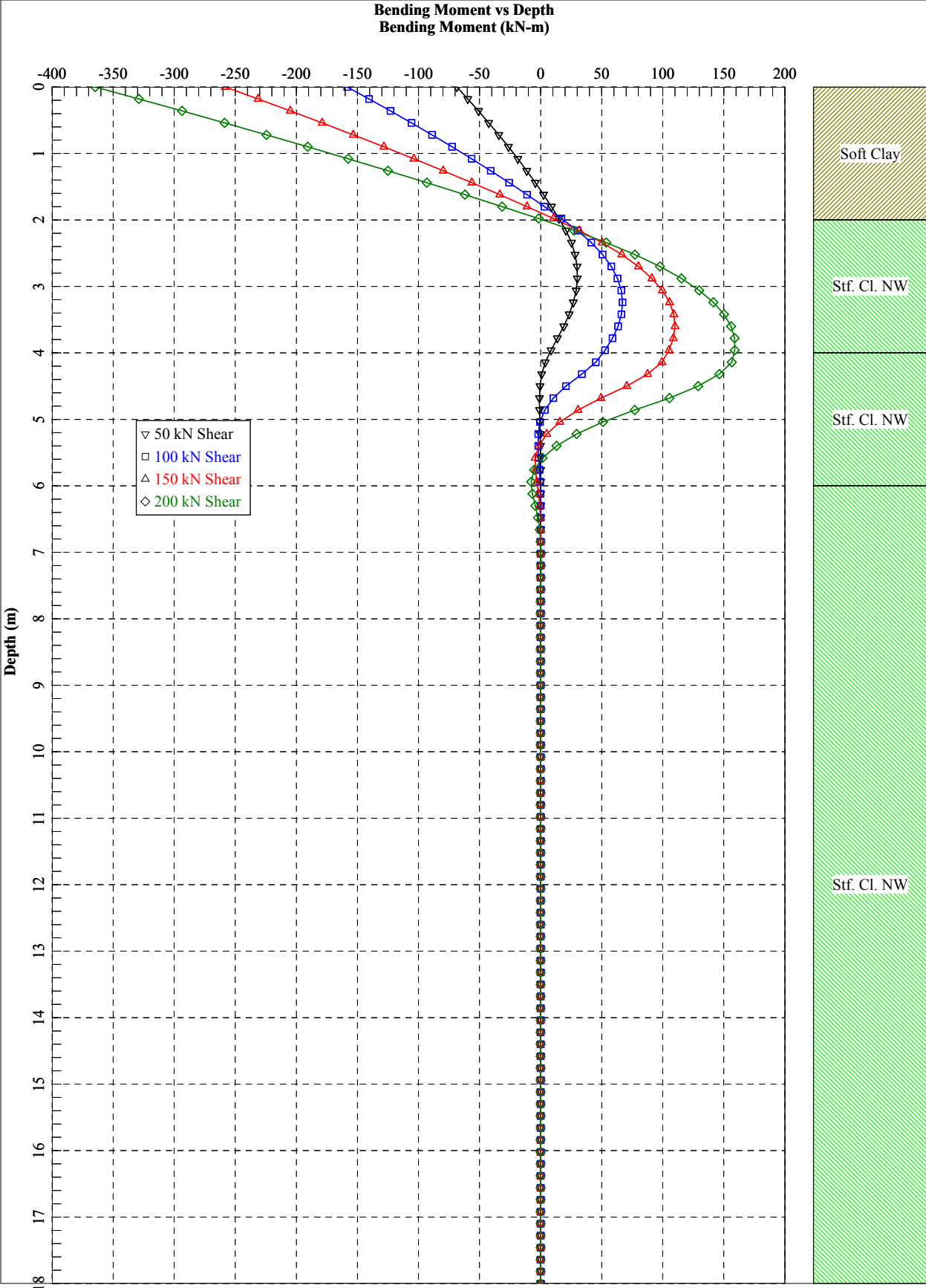

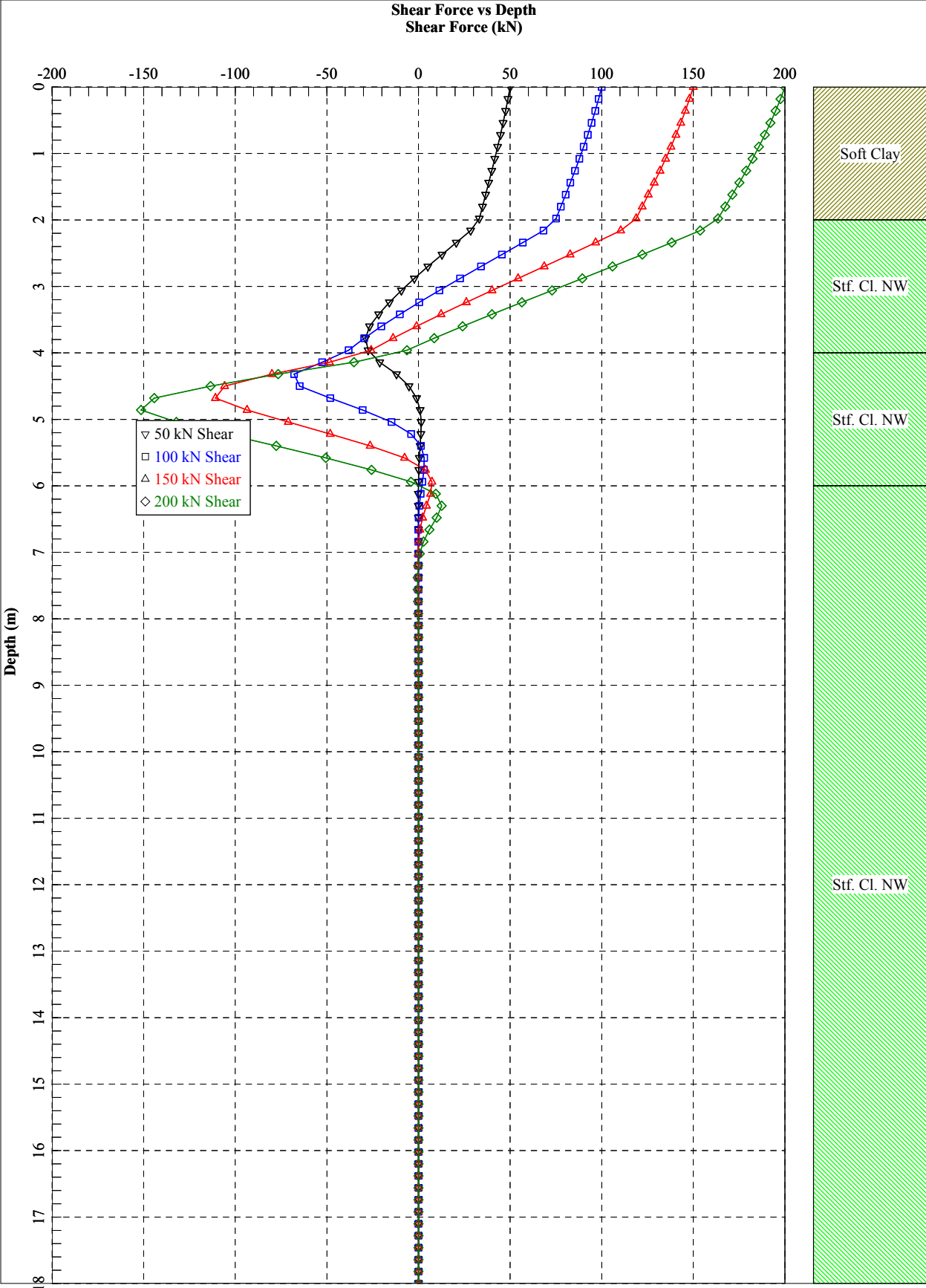

APPENDIX F
EROSION AND SEDIMENT CONTROL PLAN

Aurum Energy Park Stage 7

Aurum Road Arch Culvert Project

Environmental Construction
Methodology Report



Prepared for:
Focus Equities Inc.

Prepared by:
Stantec Consulting Ltd.

File No.: 11611104130

January 4, 2017

Revision Record							
Revision	Description	Prepared By		Checked By		Approved By	

Sign-off Sheet

This document entitled Environmental Construction Methodology Report, Aurum Energy Park Stage 7, Aurum Road Arch Culvert Project, has been prepared by Stantec Consulting Ltd. ("Stantec") for the account of Focus Equities Inc. (the "Client"). Any reliance on this document by any third party is strictly prohibited. The material in it reflects Stantec's professional judgment in light of the scope, schedule and other limitations stated in the document and in the contract between Stantec and the Client. The opinions in the document are based on conditions and information existing at the time the document was published and do not take into account any subsequent changes. In preparing the document, Stantec did not verify information supplied to it by others. Any use which a third party makes of this document is the responsibility of such third party. Such third party agrees that Stantec shall not be responsible for costs or damages of any kind, if any, suffered by it or any other third party as a result of decisions made or actions taken based on this document.

Prepared by : _____

(signature)

David Price

Reviewed by: _____
obaid
(signature)

Obaid Rizvi

Table of Contents

1.0	OVERVIEW	1
1.1	INTRODUCTION.....	1
1.2	PROJECT LOCATION.....	1
2.0	ENVIRONMENTAL PROTECTION DEVELOPMENT STAGES	2
2.1	STAGE 1 – SITE CONSTRUCTION ACCESS, LAYDOWN AREAS AND TREE REMOVAL.....	4
2.1.1	Scope	4
2.1.2	Proposed Timing	4
2.1.3	Environmental Construction Techniques.....	4
2.1.4	Erosion and Sediment Control (ESC) Measures.....	5
2.2	STAGE 2 – SITE CONTAINMENT / DELINEATION MEASURES	6
2.2.1	Scope	6
2.2.2	Timing	6
2.2.3	Environmental Construction Techniques.....	6
2.2.4	Erosion and Sediment Control (ESC) Measures.....	6
2.3	STAGE 3 – CREEK DIVERSION	6
2.3.1	Scope	6
2.3.2	Timing	7
2.3.3	Environmental Construction Techniques.....	7
2.3.4	Erosion and Sediment Control (ESC) Measures.....	8
2.4	STAGE 4 – ARCH CULVERT CONSTRUCTION	10
2.4.1	Scope	10
2.4.2	Timing	10
2.4.3	Environmental Construction Techniques.....	10
2.4.4	Erosion and Sediment Control (ESC) Measures.....	11
2.5	STAGE 5 – CREEK RE-ALIGNMENT	11
2.5.1	Scope	11
2.5.2	Timing	12
2.5.3	Environmental Construction Techniques.....	12
2.5.4	Erosion and Sediment Control (ESC) Measures.....	12
2.6	STAGE 6 – FINAL SITE RESTORATION	13
2.6.1	Scope	13
2.6.2	Timing	13
2.6.3	Environmental Construction Techniques.....	13
2.6.4	Erosion and Sediment Control (ESC) Measures.....	14
2.7	SITE MONITORING AND MAINTENANCE	14
3.0	CONCLUSION.....	15

January 4, 2017

1.0 OVERVIEW

1.1 INTRODUCTION

This report and attachments outlines the overall Environmental Construction Methodology that has been developed to mitigate potential environmental impacts to Aurum Energy Park Stage 7- Arch Culvert Project (Arch Culvert), during and immediately following the period of active construction.

Both the General Contractor (the Contractor) and all Sub-Contractors are to meet or exceed the minimum acceptable environmental mitigation and reclamation measures as outlined in the Project's Tender Documentation, this report (including Attachments), and in any subsequent meetings, discussions held between the Contractor, Sub-Contractors, Aurum Energy Park Ltd. (the Developer), and Stantec Consulting Ltd. (Stantec). This also includes any formal environmental approvals issued by municipal, provincial, and federal government bodies.

If site conditions change due to construction operation, adverse climatic conditions, etc., the Contractor, in conjunction with Stantec, shall update the information included in this plan. As such, this is referred to as a "living" document. It will be within the contractual obligations of the Contractor to maintain environmental protection by minimizing the occurrence of erosion, controlling the movement of sediment off-site, and to reduce the risk of other impacts to the environment that could occur due to the potential failure of interim Erosion and Sediment Control (ESC) measures that will be put in place during construction.

1.2 PROJECT LOCATION

The proposed project is in Northeast Edmonton, within the North Saskatchewan River Valley. This entire valley area has previously been identified by the City as an environmentally sensitive area (North Saskatchewan River Area Redevelopment (Bylaw 7188)). Therefore, it is critical that robust interim and permanent ESC measures be implemented to prevent the release of sediment and/or contamination from inadvertently entering the Creek.

1.3 HEALTH, SAFETY, SECURITY AND ENVIRONMENT (HSSE)

Stantec is committed to providing and maintaining a healthy and safe workplace for its employees and contractors and to responsibly manage all environmental aspects of its business. Several robust procedures with respect

ENVIRONMENTAL CONSTRUCTION METHODOLOGY REPORT

January 4, 2017

to HSSE are imbedded as part of Stantec's project activities. These procedures include the preparation of an initial Risk Management Strategy at the outset of a project, completion of daily on-site Field Level Risk Assessments and regular tool box safety meetings between Stantec's site representatives and Contractors. As part of Stantec's HSSE program, a comprehensive documentation process for each process is in place and must be followed.

The General Contractor for the project is also expected to have an HSSE Risk Management Plan (including Emergency Response) in place that will incorporate all construction activities. Copies of this document are to be forwarded to Stantec and the developer prior to project initiation.

The Stantec field representative(s) will attend weekly Contractor tool box safety meetings and will forward meeting notes to the Project Manager for inclusion in the project file. In addition, Stantec will also conduct internal HSSE meetings with respect to the project and these will also be filed accordingly.

In advance preparation to undertake this project, several municipal, provincial, and federal approvals (regulatory and non-regulatory) are required. The Contractor's Risk Management Plans, Emergency Contact numbers and copies of all regulatory approvals are to be posted in construction site offices. In addition, the Stantec Field Representative(s) will also have copies of all government approvals available in case officials from responsible municipal, provincial, or federal agencies undertake on-site inspections.

2.0 ENVIRONMENTAL PROTECTION DEVELOPMENT STAGES

The Aurum Energy Park Stage 7 Arch Culvert Project (Arch Culvert) will encompass the following six stages of development that will required environmental protection:

- (1) Site Construction Access, Laydown Areas, and Tree Removal
- (2) Site Containment / Delineation
- (3) Creek Diversion
- (4) Arch Culvert Construction
- (5) Creek Re-alignment
- (6) Site Restoration

Each of these stages is outlined below in terms of scope, proposed timing, environmental construction techniques, and interim ESC measures. It is noted that

January 4, 2017

each stage is not necessary sequential, and therefore timing of stages will at times overlap.

General Protection Requirements for all Stages:

- Health and Safety procedures are paramount and must be adhered to AT ALL TIMES.
- Ensure motorized equipment is in good working order and follow proper procedures for maintenance, fueling, etc. Any equipment requiring the use of fuel, lubricants, or any other hydrocarbon based products require spill kits. Any storage tanks, generators, pumps etc. that are required to be set-up in proximity to the Creek or other water bodies are required to have secondary containment.
- The General Contractor is to carry out the dust control program and noise attenuation procedures that were prepared at the outset of construction activities to minimize potential impacts to adjacent properties.
- -The use of snow fence for site delineation purposes will be minimized to allow movement through the area by mammals (e.g. snowshoe hare, deer, coyotes, etc.).
- Good housekeeping practices are to be used for construction activities including collection and containment of construction debris in appropriate waste and recycling containers, proper storage of fuels, lubricants, etc.
- The General Contractor is to prepare and carry out a waste minimization program including appropriate disposal and recycling of materials.
- The General Contractor is to monitor the site on a daily basis especially during the period of active construction and repair and/or implement any required ESC installations to restrict surface water flow beyond the site limits, especially adjacent to the Creek.
- The ESC plan as developed by Stantec and implemented by the General Contractor will be monitored daily during the construction period.
- Any changes to the ESC plan implemented on-site will be recorded and documented. The Contractor will be required to update Stantec, Drainage Services (City of Edmonton) and applicable authorities with any changes to the ESC measures.
- Daily ESC inspection reports will be undertaken by the General Contractor, and submitted to both Stantec's Field Representative and to the Project Manager.

ENVIRONMENTAL CONSTRUCTION METHODOLOGY REPORT

January 4, 2017

Weekly summary ESC Inspection reports are also required to be filed to Drainage Services (City of Edmonton) and to Stantec's Project Manager.

- The Stantec Field Representative will also provide daily notes and photographic evidence with regards to the status of construction and any installed ESC measures to the Project Manager and other appropriate members of the Stantec Project team.

2.1 STAGE 1 – SITE CONSTRUCTION ACCESS, LAYDOWN AREAS AND TREE REMOVAL

2.1.1 Scope

The objective for protection during stage 1 of the ESC work is to protect the existing creek from potential impacts of erosion, sedimentation, and debris during the construction of the site access, laydown areas and during any required tree felling and/or removal.

Trees to be felled within the access road, construction material laydown area(s), and the arch culvert construction area will also be delineated. Any trees that are required to be felled within the limit of work area must be approved by the Stantec Site Representative prior to commencement of the work. The preferred option will be agreed to prior to felling or removal.

Topsoil stripped for the access road construction that is deemed suitable for site restoration will be stockpiled in an acceptable manner and protected from contamination or supplemental dumping until needed for restoration.

2.1.2 Proposed Timing

February 1st - April 15th, 2017 pending environmental approvals.

2.1.3 Environmental Construction Techniques

General:

- The site construction access will be located within the Aurum Road Development boundary.
- The limit of work boundary is identified on Drawing Number: L100 -001.
- The limit of work boundary is to be delineated by snow fence, ESC measures and/or flagging on both sides to restrict construction activity and to minimize impact to the surrounding environment.

ENVIRONMENTAL CONSTRUCTION METHODOLOGY REPORT

January 4, 2017

Tree Removal:

- A qualified avian biologist must be retained to conduct a nest survey for trees that are to be felled during the period March 15 to August 15.
- Trees must be felled within 7 days of conducting nest surveys, provided no active nesting birds are found.
- If nests are found to be present in trees that will require felling, a mitigation plan will be developed to address potential impacts and the subsequent timing of tree felling.
- Tree felling and grubbing will be restricted to the limit of work boundary as defined on drawing L100 -001 and verified by field reconnaissance and surveying.
- ESC measures will be reviewed during and after tree felling for compliance. If required, any additional recommended ESC measures will be installed as soon as possible for protection of the ravine and creek.

2.1.4 Erosion and Sediment Control (ESC) Measures

ESC measures shall include:

- Protection of the existing creek from erosion, sedimentation, and/or debris. Minimum measures include silt fencing and straw wattles on both sides and along the entire length of the creek where potential impacts may occur.
- Felled trees and mulch will be left in place to act as erosion control measures until the site access and construction laydown areas are constructed and until site grading commences.
- Trees that are required to be felled for safety concerns outside the limit of work boundary will have their stumps left intact (approximately 5m outside the limits) to avoid excess soil disturbance, particularly in erosion prone areas, including side slopes, cut and fill areas, etc.
- Suitable topsoil is to be stripped and set aside in a stockpile for future use should be protected by a blade cut around the entire perimeter, and followed by the installation of silt fence, to restrict and offsite sediment release during spring melt or periods of heavy precipitation events.

January 4, 2017

2.2 STAGE 2 – SITE CONTAINMENT / DELINEATION MEASURES

2.2.1 Scope

The objective for protection during stage 2 is the installation of ESC and safety measures along the limit of work boundary to delineate the limit of work, restrict construction activity and to minimize impact to the surrounding environment.

2.2.2 Timing

April 1st – April 15th, 2017

2.2.3 Environmental Construction Techniques

General:

- The limit of work boundary is identified on Drawing Number: L100 -001.
- Construction is to commence only when ESC measures are in place and have been inspected by Stantec personnel (or designated ESC specialists).
- Implement wet weather restrictions to construction activity as appropriate.
- Restrict construction activity to limit of work area previously defined and surveyed.

2.2.4 Erosion and Sediment Control (ESC) Measures

- Silt fence and straw wattles are to be installed along the limit of work boundary for project as outlined on Drawing Number: L100 -002 and for any other areas that may be impacted by construction.
- ESC measures parallel to the creek must be implemented prior to any work that may impact water quality. This will serve as a proactive procedure in minimizing environmental impacts caused by minor or major climatic events.

2.3 STAGE 3 – CREEK DIVERSION

2.3.1 Scope

Temporary creek diversion measures will be required to construct the arch culvert, retaining walls, creek channel re-alignment, wildlife passage and environmental restoration.

ENVIRONMENTAL CONSTRUCTION METHODOLOGY REPORT

January 4, 2017

2.3.2 Timing

May 15th to June 15th, 2017

2.3.3 Environmental Construction Techniques

General:

- The creek diversion will occur within the limit of work line established in Stage 2. The recommended creek diversion requirements are identified in Drawing Number: L100 -003.
- The General Contractor will advise, document and communicate to the Stantec Representative when work is occurring at the limit of work boundary line.
- The creek diversion will consist of 2 Phases. Phase 1 will include the installation of a temporary diversion pipe (Pipe A) to isolate the area for the installation of the interim diversion pipe (Pipe B) which will redirect the flow of the creek during the construction of the arch culvert, retaining walls and the creek re-alignment.
- During the installation of the temporary diversion Pipe A and the interim diversion Pipe B along the north side of the creek, the Contractor must have an ESC specialist present to ensure that debris does not enter the creek. The Stantec ESC specialist will be updated daily with the progress of the work and contacted when measures are being installed and/or revised.
- Creek turbidity should be monitored upstream and downstream of the limit of work area during the installation diversion pipes. Once the interim diversion Pipe B is installed, turbidity readings should also be taken daily, to ensure that construction debris does not enter the pipe or the creek.
- As part of the interim diversion Pipe B installation, containment berms are to be constructed (approximate 3m in height) both upstream and downstream of the construction zone, and capped with a rubber membrane (or other similar material). The intent of the berms will be to mitigate, contain and protect the active construction area and downstream creek bed from peak climatic events.
- Rip-rap is to be placed at both the upstream and downstream berms. The rip-rap at the upstream berm is to be constructed as part of a forebay that will permit surface water to settle, prior to entering the interim diversion Pipe B. The rip-rap adjacent to the downstream berm is also to be in a settling basin, that will dissipate energy of the surface water exiting the interim diversion Pipe B and entering the undisturbed creek downstream of the construction zone.

ENVIRONMENTAL CONSTRUCTION METHODOLOGY REPORT

January 4, 2017

- A contingency plan will be in place as a precaution in case of diversion pipe failure (e.g. construction activity causes a break in the pipe, or heavy precipitation results in surface water overflowing the upstream berm). Such a plan will include the on-site storage of pumping equipment and hoses that can be used to direct the surface water around the site to the creek, downstream of the active construction zone.
- If a failure of a diversion pipe occurs, turbidity readings of the stream must be taken, and if acceptable turbidity levels are exceeded, Alberta Environment and Parks must be notified via the Environment Emergency Hotline and followed up with the required written communication (i.e. "7 Day Letter").
- As the sections of the creek in the active construction zone are dewatered, a Qualified Aquatic Environmental Specialist (QAES) must be present to capture and record fish prior to release (a requirement of the Code of Practice for Stream Crossings under *The Water Act*). The pumping equipment used to dewater this section of the creek must be equipped with appropriate fish screens.
- Construction is to commence only when ESC measures are in place and have been inspected by Stantec personnel (or designated ESC specialists).
- Implement wet weather restrictions to construction activity as appropriate.
- Restrict construction activity to working area previously defined and surveyed.

2.3.4 Erosion and Sediment Control (ESC) Measures

- Maintain silt fencing and straw wattles adjacent to edge of creek. Adjust any ESC measures to adapt to the work during the installation of the creek diversion Pipe A and Pipe B.

Temporary Diversion Pipe A:

- Install isolation structures to divert creek within the existing creek bed at the upstream and downstream limits of temporary diversion Pipe A to divert the stream prior to installation of the temporary pipe.
- Install the temporary diversion Pipe A and protect the upstream and downstream pipe areas with riprap to mitigate potential erosion when pipe is conveying the creek.
- Adjust the isolation structures at the downstream end of the pipe to allow flow prior to adjusting the upstream isolation structures to allow the creek to flow through the pipe. Additional stabilization and diversion material may be required

ENVIRONMENTAL CONSTRUCTION METHODOLOGY REPORT

January 4, 2017

at the upstream end of the pipe to ensure the creek is fully diverted through the temporary diversion Pipe A.

- While the diverted section of the creek is dewatering, a Qualified Aquatic Environmental Specialist (QAES) must be present to capture and record fish prior to release (a requirement of the Code of Practice for Stream Crossings under *The Water Act*). The pumping equipment used to dewater this section of the creek must be equipped with appropriate fish screens.
- Following dewatering the contractor will adjust any ESC measures to protect the remaining creek and temporary diversion Pipe A during the installation of the interim diversion Pipe B.

Interim Diversion Pipe B:

- Install isolation structures within the existing creek bed at the upstream and downstream interim Pipe B limits to divert the stream prior to installation of the interim diversion pipe.
- Install the interim diversion Pipe B and protect the upstream and downstream pipe areas with riprap to mitigate potential erosion when pipe is conveying the creek. It is recommended that half of the 3.0m berm adjacent to the bank be constructed over the upstream and downstream ends of the interim diversion Pipe B to the limit of the isolation structure to provide pipe stability and to minimize the ESC work required and probability of siltation when the creek is diverted.
- Adjust the isolation structures at the downstream end of Pipe B to allow flow prior to adjusting the upstream isolation structures to allow the creek to flow through the pipe. Additional stabilization and diversion material may be required at the upstream end of the pipe to ensure the creek is fully diverted through the interim diversion Pipe B.
- While the diverted section of the creek is dewatering, a Qualified Aquatic Environmental Specialist (QAES) must be present to capture and record fish prior to release (a requirement of the Code of Practice for Stream Crossings under *The Water Act*). The pumping equipment used to dewater this section of the creek must be equipped with appropriate fish screens.
- Completion of the downstream 3.0m containment berm will be required following certification and clearance from the Aquatic Environmental Specialist.
- Once the creek has been fully diverted, both the upstream and downstream reaches of the creek adjacent to the active construction zone should be monitored on a daily basis. Several resident beaver are active in the creek, both

ENVIRONMENTAL CONSTRUCTION METHODOLOGY REPORT

January 4, 2017

upstream and downstream of the construction zone, and any debris resulting from their activity might plug the interim diversion Pipe B. Therefore, it is preferable to install trash racks/gates at both the upstream and downstream openings of the diversion pipe.

- Temporary diversion Pipe A shall be removed once the interim diversion Pipe B is operational and the site shall be reclaimed to allow for future installation of the creek re-alignment.
- Daily inspections of the upstream and downstream berms should be conducted to ensure that they are functioning as designed. Absolutely no construction equipment is to impact these berms or to be near the undisturbed portions of the creek, unless the Stantec Field Representative is notified prior or in the case of a health, safety, or environmental emergency. If this occurs, appropriate regulatory/emergency government officials are to be notified as per the site's emergency response plan.

2.4 STAGE 4 – ARCH CULVERT CONSTRUCTION

2.4.1 Scope

This stage includes construction of a pre-cast concrete arch culvert across the disturbed area of the former creek bed, and ancillary works including concrete wing walls on either side of the culvert, earth berms, and a road structure across the top of the culvert.

2.4.2 Timing

July 1st – August 30th, 2017

2.4.3 Environmental Construction Techniques

General:

- The arch culvert and roadway construction will occur within the limit of work line established in Stage 1. The recommended ESC requirements are identified in Drawing Number: L100 -004.
- The limit of work boundary is identified on Drawing Number: L100 -001.
- Construction is to commence only when ESC measures are in place and have been inspected by Stantec personnel (or designated ESC specialists).
- Environmental Construction Techniques will include the use of silt fencing, straw wattles, diversion swales, dams, sediment forebays and any other measures

January 4, 2017

necessary to mitigate the potential for erosion in and around the work site and creek.

- Implement wet weather restrictions to construction activity as appropriate.
- Restrict construction activity to limit of work area previously defined and surveyed.
- The General Contractor is to carry out the dust control program and noise attenuation procedures that were prepared at the outset of construction activities to minimize potential impacts to adjacent properties.
- Any storage tanks, generators, pumps etc. that are required to be set-up in proximity to the Creek or other water bodies are required to have secondary containment.

2.4.4 Erosion and Sediment Control (ESC) Measures

- Silt fence, straw wattles and diversion ditches shall be installed to divert overland drainage away from active work areas.
- Sediment forebays will be installed at key locations within the limit of work to collect runoff and allow sediment to drop out prior to dewatering.
- The construction of the arch culvert will require the preparation of "shear keys" that will be put in place prior to the forming of the wing walls. This process will necessitate a significant removal of native material. During this process, interim ESC measures must be put in place to mitigate any erosion or sediment from being transported to the valley floor during significant precipitation events. Silt Fence, Straw Wattles, and Check Dams will be installed as required during this stage.
- ESC measures will be adjusted and updated daily to reflect the progress of the work and the conditions of the site.

2.5 STAGE 5 – CREEK RE-ALIGNMENT

2.5.1 Scope

Once the Arch Culvert structure, retaining walls and roadway base have been installed, the former creek will be re-aligned and constructed as per the approved drawings. When creek re-alignment work is complete the creek water will be directed to the new channel to allow for the remaining site reclamation work to commence.

ENVIRONMENTAL CONSTRUCTION METHODOLOGY REPORT

January 4, 2017

2.5.2 Timing

August 15th - September 30th, 2017

2.5.3 Environmental Construction Techniques

General:

- The creek re-alignment work will occur within the limit of work line established in Stage 1. The recommended ESC requirements are identified in Drawing Number: L100 -005.
- The limit of work boundary is identified on Drawing Number: L100 -001.
- Construction is to commence only when ESC measures are in place and have been inspected by Stantec personnel (or designated ESC specialists).
- Environmental Construction Techniques will include the use of silt fencing, straw wattles, diversion ditches, ditch checks, sediment forebays and any other measures necessary to mitigate the potential for erosion in and around the work site and creek.
- Implement wet weather restrictions to construction activity as appropriate.
- Restrict construction activity to limit of work area previously defined and surveyed.
- Any storage tanks, generators, pumps etc. that are required to be set-up in proximity to the Creek or other water bodies are required to have secondary containment.
- ESC measures will be adjusted and updated daily to reflect the progress of the work and the conditions of the site.

2.5.4 Erosion and Sediment Control (ESC) Measures

- The construction of the creek re-alignment will necessitate the significant movement of boulders and rock material. During this process, interim ESC measures must be put in place to mitigate any erosion or sediment from being transported to the valley floor during a significant precipitation event(s). Silt Fence, Straw Wattles, and Check Dams will be installed as required during this stage.
- At the time of the release of the surface water upstream into the realigned creek bed, turbidity readings must be undertaken to ensure that turbidity levels are

January 4, 2017

within acceptable parameters. The release should be regulated, to not cause a sudden “flush” of the water throughout the new stream bed.

2.6 STAGE 6 – FINAL SITE RESTORATION

2.6.1 Scope

The final stage of construction includes the removal of portions of the interim diversion Pipe B, decommissioning of the remainder of diversion Pipe B, restoration of the wildlife passage bench and surrounding slopes, slope reclamation, ESC measures and installation of vegetation as per the approved landscape plans.

2.6.2 Timing

September 2017 and Spring 2018.

2.6.3 Environmental Construction Techniques

General:

- The recommended ESC requirements are identified in Drawing Number: L100 - 006.
- The limit of work boundary is identified on Drawing Number: L100 -001.
- The interim diversion Pipe B removal requirements are identified on Drawing Number: L100 -004.
- Construction is to commence only when ESC measures are in place and have been inspected by Stantec personnel (or designated ESC specialists).
- Environmental Construction Techniques will include the use of silt fencing, straw wattles, brush layering, hydro-seeding, erosion control blankets and any other measures necessary to mitigate the potential for erosion in and around the creek.
- Implement wet weather restrictions to construction activity as appropriate.
- Restrict construction activity to limit of work area previously defined and surveyed.
- The General Contractor is to carry out the dust control program and noise attenuation procedures that were prepared at the outset of construction activities to minimize potential impacts to adjacent properties.

ENVIRONMENTAL CONSTRUCTION METHODOLOGY REPORT

January 4, 2017

- Any storage tanks, generators, pumps etc. that are required to be set-up in proximity to the Creek or other water bodies are required to have secondary containment.
- ESC measures will be adjusted and updated daily to reflect the progress of the work and the conditions of the site.

2.6.4 Erosion and Sediment Control (ESC) Measures

- Silt fence, straw wattles, brush layering, hydro-seeding, erosion blankets, bio-engineering and planting will be implements as per the approved landscape plans.
- The site reclamation work will necessitate a significant movement of soil and soft landscape material. During this process, interim ESC measures must be put in place to mitigate any erosion or sediment from being transported to the valley floor during a significant precipitation event(s). Silt Fence, Straw Wattles, and Check Dams will be installed as required during this stage.
- All areas within the work limits that are to final grade must be hydro-seeded and blanketed immediately following construction. This will enable the area to become vegetated and mitigate the potential for erosion.
- Trees, shrubs, and other plantings identified on the approved landscape drawings are to be planted as soon as appropriate following completion of the site works.
- ESC measures including silt fence and straw wattles are to be removed at time of FAC.

2.7 SITE MONITORING AND MAINTENANCE

- The site will be monitored 7 days per week during the period of active construction and up until the site has been restored. A report, including a photographic record, will be submitted by the contractor to Stantec daily during the construction period. The Stantec field representative will also maintain a daily diary of construction activities and reclamation measures that have been installed by the contractor.
- Close attention will be paid to the site during rainfall and any other major climatic events and all erosion control BMPs will be repaired as necessary.
- If any releases to Aurum Creek occur, Alberta Environment and Parks must be notified via the Toll Free Environment Hot Line at 1-800-222-6514.

ENVIRONMENTAL CONSTRUCTION METHODOLOGY REPORT

January 4, 2017

- During construction, it is recommended that the site have 24-hour security. There have been numerous instances on other job sites in the recent past where construction equipment and fuel were tampered with and either stolen or dumped. Due to this project being in a sensitive valley, and adjacent to the North Saskatchewan River, care must be taken to ensure avoidance of such criminal and potentially environmental harmful activities.

3.0 CONCLUSION

The information presented in this report and attachments has been prepared to minimize the potential for environmental impacts to occur on-site prior to, during and post-construction of the Aurum Stage 7 Arch Culvert. As mentioned previously, this is a “living” document, and as such information will be updated on a continual basis, throughout the span of the project. Communication between all parties including contractors, Stantec, and Focus Equities Inc. will be of utmost importance in ensuring the success of this project.

DRAWINGS

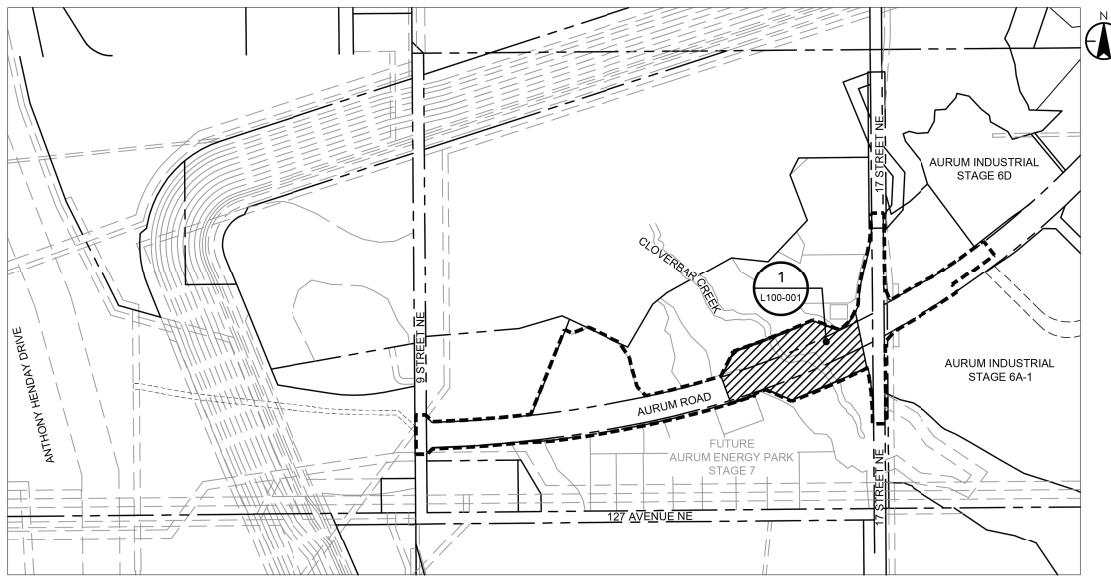

KEY PLAN
SCALE: N.T.S.

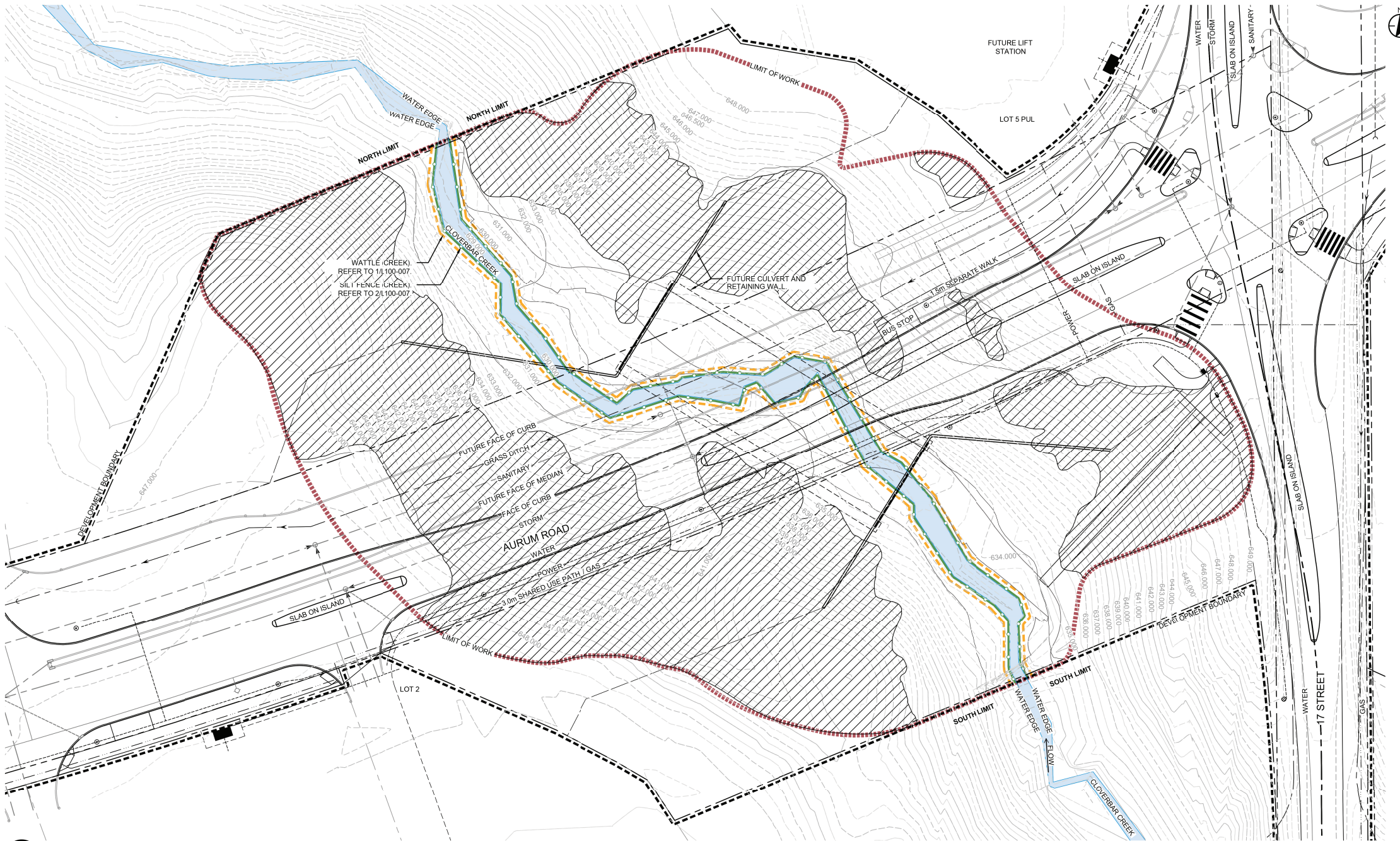

1 STAGE 1 SITE ACCESS / LAYDOWN / TREE REMOVAL - ESC REQUIREMENTS
SCALE: 1:500

LEGEND

GRUBBING CLEARING AND GRUBBING



Stantec Consulting Ltd.
10160 - 112 Street
Edmonton AB Canada
Tel. 780.917.7000
www.stantec.com

Copyright Reserved
The Contractor shall verify and be responsible for all dimensions. DO NOT scale the drawing - any errors or omissions shall be reported to Stantec without delay. The Copyrights to all designs and drawings are the property of Stantec. Reproduction or use for any purpose other than that authorized by Stantec is forbidden.

Legend

- MANHOLE
- ⊙ LIGHT STANDARD
- ⊞ TELEPHONE / VIDEO PEDESTAL
- TRANSFORMER
- ⊕ HYDRANT
- EDGE OF WATER
- - - DEVELOPMENT BOUNDARY
- ▬▬▬▬▬ LIMIT OF WORK
- SILT FENCE
- WATTLE

Notes
UTILITY SETBACKS

LANDSCAPE CONTRACTOR TO CALL 'ALBERTA ONE-CALL' AT 1-800-242-3447 TO HAVE ALL EXISTING SITE UTILITIES LOCATED PRIOR TO CONSTRUCTION AND PLANT NO CLOSER THAN THE FOLLOWING DIMENSIONS FROM THE SERVICES:

1. 1.0m FROM POWER LINES
2. 3.5m FROM ALL POWER HARDWARE
3. 1.8m FROM WATER MAINS, WATER VALVES, MANUAL AIRVENTS, AND SERVICES
4. 2.0m FROM SEWER MAINS, AND MANHOLES
5. 1.8m FROM SEWER SERVICES
6. 1.5m FROM GAS (NO TREES WITHIN EASEMENT)
7. 7.5m FROM STREET CORNERS.
8. 3.5m FROM FIRE HYDRANTS
9. 1.5m FROM DRIVEWAYS
10. 1.5m FROM ALLEY ACCESSES
11. 1.0m FROM SIDEWALKS
- OR AS PER APPROVED ENG. CROSS SECTIONS
12. 3.5m FROM TRANSIT ZONES
13. 3.0m FROM PRIVATE PROPERTY BOUNDARY
14. 1.25m FROM COLLECTOR ROAD CURB FACE
15. 1.25m FROM LOCAL ROAD CURB FACE
16. 2.0m FROM ARTERIAL ROAD CURB FACE
17. 3.5m FROM YIELD AND STOP SIGNS
18. 3.5m FROM BUS STOP SIGNS
19. 2.0m FROM ALL OTHER SIGNS
20. 1.0m FROM OTHER UNDERGROUND UTILITIES
21. 3.5m FROM TELUS PEDESTALS
22. 2.0m FROM TELUS DUCT STRUCTURE
23. 1.0m FROM TELUS CABLE FACILITIES

LANDSCAPE CONTRACTOR IS RESPONSIBLE FOR DAMAGES AND LIABILITIES INCURRED BY DAMAGES TO SITE UTILITIES.

Development Engineer, Sustainable Development			
Approvals			YY.MM.DD
Revision	By	Appd.	YY.MM.DD
1ST ISSUE FOR REVIEW	KM/KH/CB	DP	17.01.13
Issued	By	Appd.	YY.MM.DD
File Name: LA_AurumRivineESC.dwg	Dwn.	Chkd.	Dign.
Permit-Seal			YY.MM.DD



David A. Price

Client/Project
AURUM INDUSTRIAL DEVELOPMENT PARTNERSHIP

AURUM ROAD
17 STREET NE TO 9 STREET NE
Edmonton, AB

Title
STAGE 1 SITE ACCESS / LAYDOWN / TREE REMOVAL ESC REQUIREMENTS

Project No. 1161-104130
Scale 1:500

Drawing No. 1100-001
1 of 8

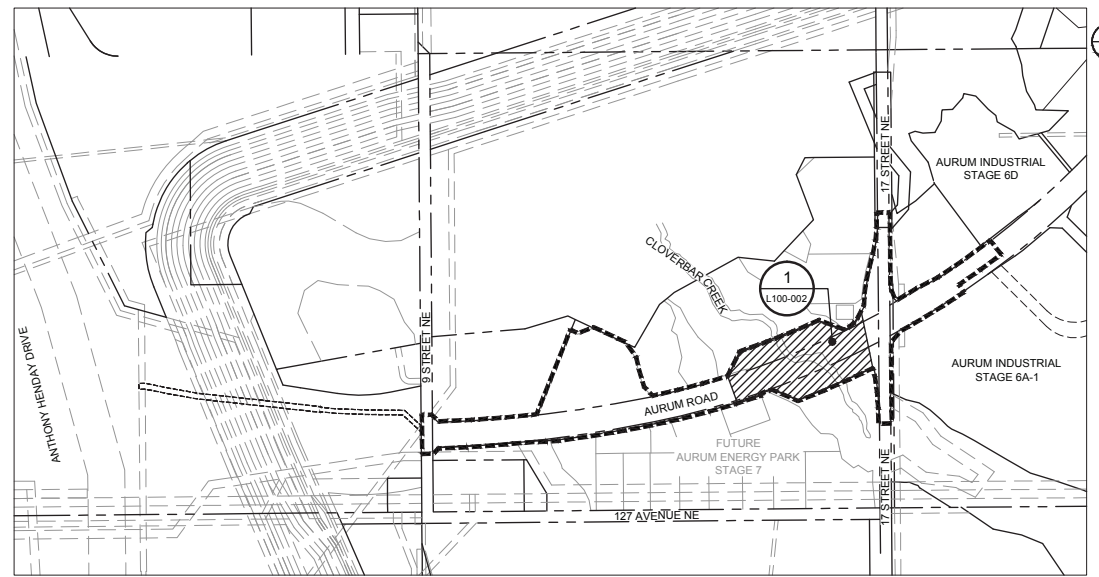

KEY PLAN
SCALE: N.T.S.

NOTES:

- ALL DISTURBED AREAS TO BE TOPSOILED, HYDROSEEDDED, AND PROTECTED WITH SC150NB EROSION CONTROL BLANKET, UNLESS OTHERWISE SPECIFIED
- ALL WATER COLLECTED WITHIN SEDIMENT FOREBAY A & D TO BE PUMPED OUT AFTER ANY STORM EVENT OR AS REQUIRED. WATER TO BE CLEAN AND FREE OF DEBRIS AND SUSPENDED SEDIMENTS PRIOR TO PUMPING. SKIMMERS AND FILTER BAGS WILL BE USED AS REQUIRED TO ENSURE NO SILTATION IN PUMP OUT LOCATION. CLEAN WATER TO BE PUMPED INTO NATURAL/VEGETATED AREAS ADJACENT TO SEDIMENT PONDS.

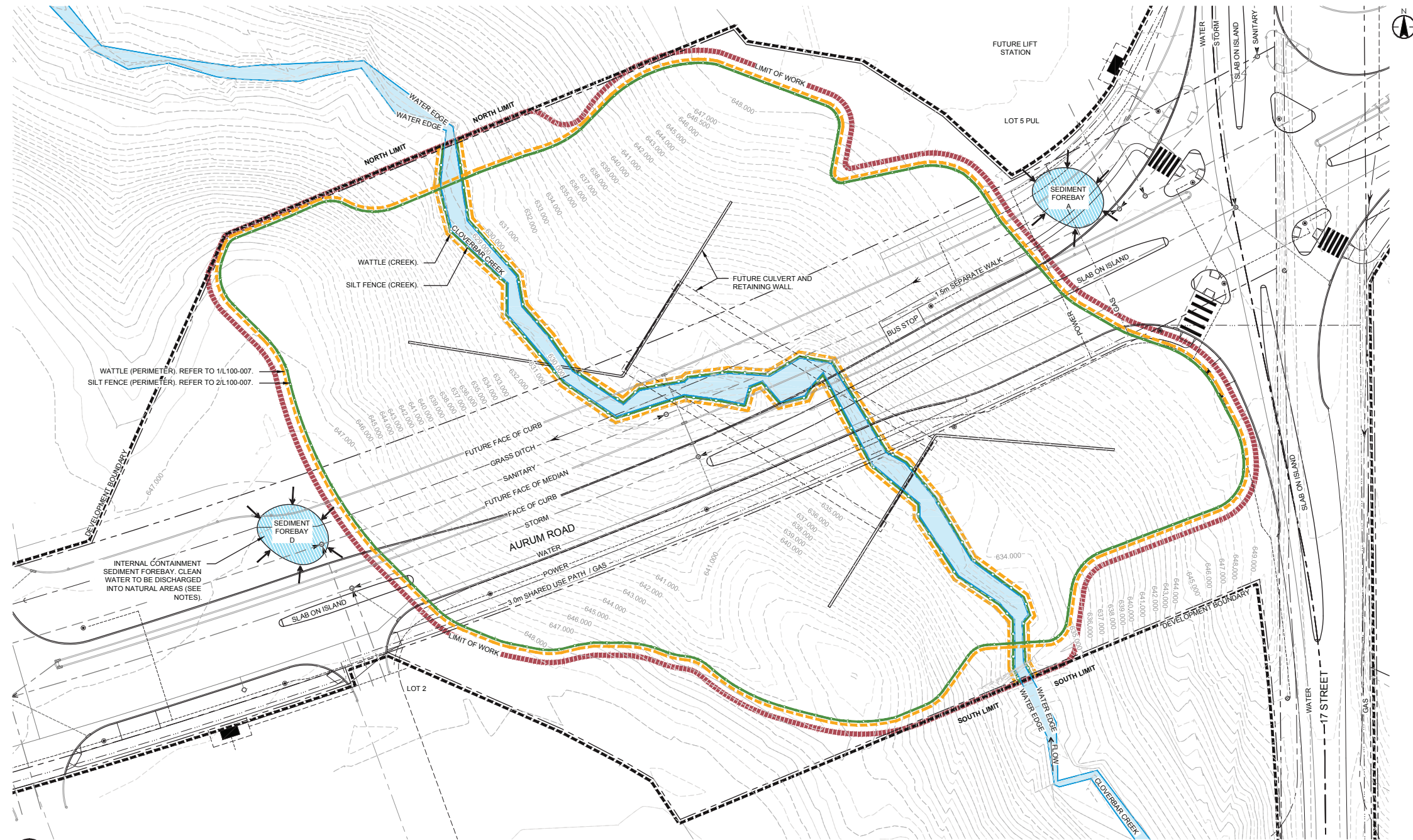

1 STAGE 2 SITE CONTAINMENT / DELINEATION - ESC REQUIREMENTS
SCALE: 1:500



Stantec Consulting Ltd.
10160 - 112 Street
Edmonton AB Canada
Tel. 780.917.7000
www.stantec.com

Copyright Reserved

The Contractor shall verify and be responsible for all dimensions. DO NOT scale the drawing - any errors or omissions shall be reported to Stantec without delay. The Copyrights to all designs and drawings are the property of Stantec. Reproduction or use for any purpose other than that authorized by Stantec is forbidden.

Legend

- MANHOLE
- ⊙ LIGHT STANDARD
- ☎ TELEPHONE / VIDEO PEDESTAL
- TRANSFORMER
- ⊕ HYDRANT
- EDGE OF WATER
- - - DEVELOPMENT BOUNDARY
- ▬▬▬▬▬ LIMIT OF WORK
- SILT FENCE
- WATTLE

Notes

UTILITY SETBACKS

LANDSCAPE CONTRACTOR TO CALL 'ALBERTA ONE-CALL' AT 1-800-242-3447 TO HAVE ALL EXISTING SITE UTILITIES LOCATED PRIOR TO CONSTRUCTION AND PLANT NO CLOSER THAN THE FOLLOWING DIMENSIONS FROM THE SERVICES:

- 1.0m FROM POWER LINES
- 3.5m FROM ALL POWER HARDWARE
- 1.8m FROM WATER MAINS, WATER VALVES, MANUAL AIRVENTS, AND SERVICES
- 2.0m FROM SEWER MAINS, AND MANHOLES
- 1.8m FROM SEWER SERVICES
- 1.5m FROM GAS (NO TREES WITHIN EASEMENT)
- 7.5m FROM STREET CORNERS.
- 3.5m FROM FIRE HYDRANTS.
- 1.5m FROM DRIVEWAYS
- 1.5m FROM ALLEY ACCESSSES
- 1.0m FROM SIDEWALKS
- OR AS PER APPROVED ENG. CROSS SECTIONS
- 3.5m FROM TRANSIT ZONES
- 3.0m FROM PRIVATE PROPERTY BOUNDARY
- 1.25m FROM COLLECTOR ROAD CURB FACE
- 1.25m FROM LOCAL ROAD CURB FACE
- 2.0m FROM ARTERIAL ROAD CURB FACE
- 3.5m FROM YIELD AND STOP SIGNS
- 3.5m FROM BUS STOP SIGNS
- 2.0m FROM ALL OTHER SIGNS
- 1.0m FROM OTHER UNDERGROUND UTILITIES
- 3.5m FROM TELUS PEDESTALS
- 2.0m FROM TELUS DUCT STRUCTURE
- 1.0m FROM TELUS CABLE FACILITIES

LANDSCAPE CONTRACTOR IS RESPONSIBLE FOR DAMAGES AND LIABILITIES INCURRED BY DAMAGES TO SITE UTILITIES.

Development Engineer, Sustainable Development			
Approvals			YY.MM.DD
Revision		By	Appd. YY.MM.DD
1ST ISSUE FOR REVIEW	CM/KH/CB	DP	17.01.13
Issued		By	Appd. YY.MM.DD
File Name: LA_AurumRainESC_cover.dwg	Dwn.	Chkd.	Dgdn.
Permit-Seal			



David A. Price

Client/Project
AURUM INDUSTRIAL DEVELOPMENT PARTNERSHIP

AURUM ROAD
17 STREET NE TO 9 STREET NE
Edmonton, AB

Title
STAGE 2 SITE CONTAINMENT / DELINEATION ESC REQUIREMENTS

Project No. 1161-104130
Scale 1:500

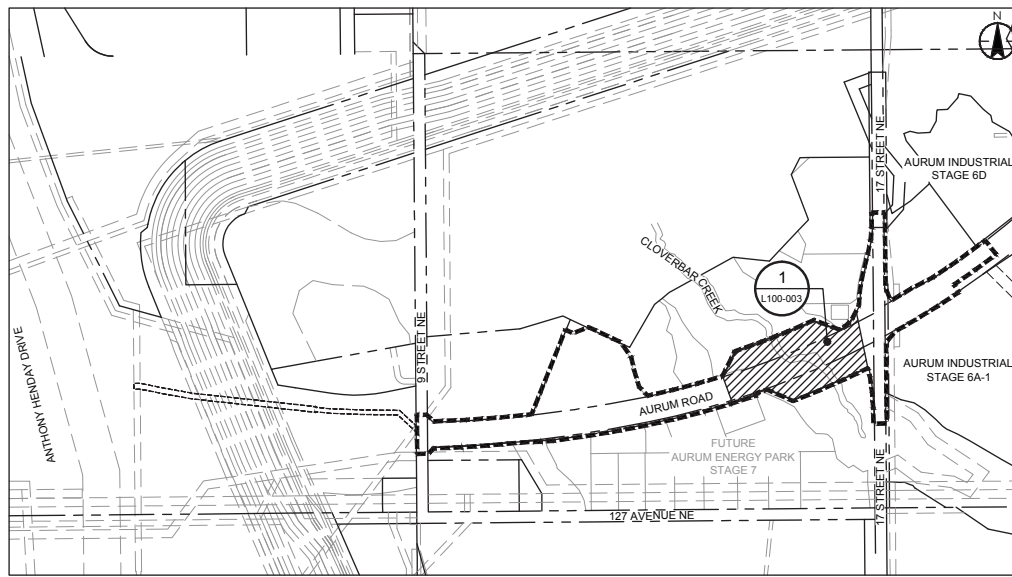

KEY PLAN
SCALE: N.T.S.

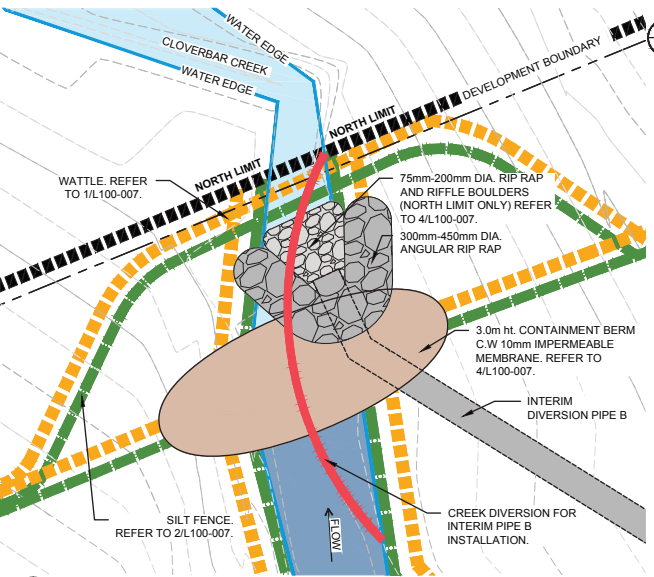

2 NORTH LIMIT BERM DIVERSION ENLARGMENT
SCALE: 1:150

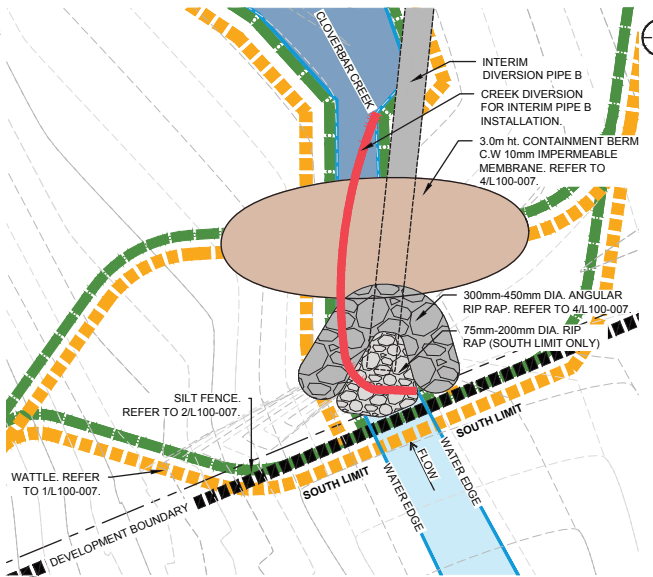

3 SOUTH LIMIT BERM DIVERSION ENLARGMENT
SCALE: 1:150

- NOTES:**
1. ALL DISTURBED AREAS TO BE TOPSOILED, HYDROSEEDED, AND PROTECTED WITH SC150NB EROSION CONTROL BLANKET, UNLESS OTHERWISE SPECIFIED.
 2. ALL WATER COLLECTED WITHIN SEDIMENT FOREBAY A & D TO BE PUMPED OUT AFTER ANY STORM EVENT OR AS REQUIRED. WATER TO BE CLEAN AND FREE OF DEBRIS AND SUSPENDED SEDIMENTS PRIOR TO PUMPING. SKIMMERS AND FILTER BAGS WILL BE USED AS REQUIRED TO ENSURE NO SILTATION IN PUMP OUT LOCATION. CLEAN WATER TO BE PUMPED INTO NATURAL/VEGETATED AREAS ADJACENT TO SEDIMENT POND.
 3. A 10mm IMPERMEABLE MEMBRANE IS TO BE INSTALLED ALONG THE ENTIRE LENGTH OF THE CONTAINMENT BERM. THE IMPERMEABLE MEMBRANE IS TO BE REMOVED ONCE DRILLING OPERATIONS ARE COMPLETED.

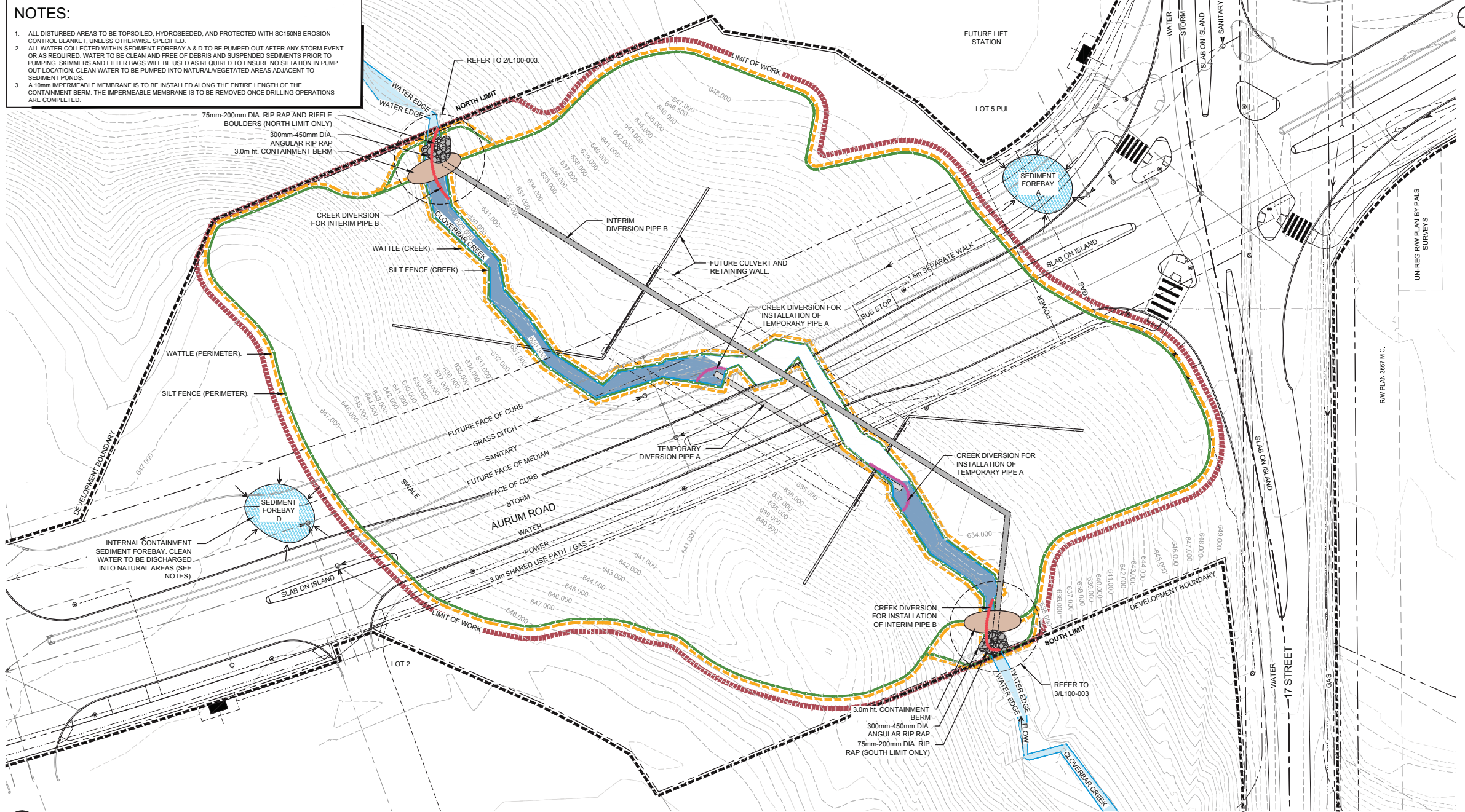

1 STAGE 3 CREEK DIVERSION - ESC REQUIREMENTS
SCALE: 1:500



Stantec Consulting Ltd.
10160 - 112 Street
Edmonton AB Canada
Tel. 780.917.7000
www.stantec.com

Copyright Reserved
The Contractor shall verify and be responsible for all dimensions. DO NOT scale the drawing - any errors or omissions shall be reported to Stantec without delay. The Copyrights to all designs and drawings are the property of Stantec. Reproduction or use for any purpose other than that authorized by Stantec is forbidden.

- Legend**
- MANHOLE
 - LIGHT STANDARD
 - ⊠ TELEPHONE / VIDEO PEDESTAL
 - TRANSFORMER
 - HYDRANT
 - LIMIT OF WORK
 - - - DEVELOPMENT BOUNDARY
 - - - TEMPORARY CREEK DIVERSION PIPE A
 - - - INTERIM CREEK DIVERSION PIPE B
 - SILT FENCE
 - WATTLE
 - EDGE OF WATER

- Notes**
- UTILITY SETBACKS**
- LANDSCAPE CONTRACTOR TO CALL 'ALBERTA ONE-CALL' AT 1-800-242-3447 TO HAVE ALL EXISTING SITE UTILITIES LOCATED PRIOR TO CONSTRUCTION AND PLANT NO CLOSER THAN THE FOLLOWING DIMENSIONS FROM THE SERVICES:
1. 1.0m FROM POWER LINES
 2. 3.5m FROM ALL POWER HARDWARE
 3. 1.8m FROM WATER MAINS, WATER VALVES, MANUAL AIRVENTS, AND SERVICES
 4. 2.0m FROM SEWER MAINS, AND MANHOLES
 5. 1.8m FROM SEWER SERVICES
 6. 1.5m FROM GAS (NO TREES WITHIN EASEMENT)
 7. 7.5m FROM STREET CORNERS.
 8. 3.5m FROM FIRE HYDRANTS.
 9. 1.5m FROM DRIVEWAYS
 10. 1.5m FROM ALLEY ACCESSES
 11. 1.0m FROM SIDEWALKS
 - OR AS PER APPROVED ENG. CROSS SECTIONS
 12. 3.5m FROM TRANSIT ZONES
 13. 3.0m FROM PRIVATE PROPERTY BOUNDARY
 14. 1.25m FROM COLLECTOR ROAD CURB FACE
 15. 1.25m FROM LOCAL ROAD CURB FACE
 16. 2.0m FROM ARTERIAL ROAD CURB FACE
 17. 3.5m FROM YIELD AND STOP SIGNS
 18. 3.5m FROM BUS STOP SIGNS
 19. 2.0m FROM ALL OTHER SIGNS
 20. 1.0m FROM OTHER UNDERGROUND UTILITIES
 21. 3.5m FROM TELUS PEDESTALS
 22. 2.0m FROM TELUS DUCT STRUCTURE
 23. 1.0m FROM TELUS CABLE FACILITIES

LANDSCAPE CONTRACTOR IS RESPONSIBLE FOR DAMAGES AND LIABILITIES INCURRED BY DAMAGES TO SITE UTILITIES.

Development Engineer, Sustainable Development					
Approvals				YY.MM.DD	
Revision		By	Appd.	YY.MM.DD	
1ST ISSUE FOR REVIEW		KM/KH/CB	DP	17.01.13	
Issued		By	Appd.	YY.MM.DD	
File Name:	LA_AurumRainESC_cover.dwg	Dwn.	Chkd.	Dgtr.	YY.MM.DD

Permit-Seal



Client/Project
AURUM INDUSTRIAL DEVELOPMENT PARTNERSHIP
AURUM ROAD
17 STREET NE TO 9 STREET NE
Edmonton, AB

Title
STAGE 3 CREEK DIVERSION ESC REQUIREMENTS

Project No. 1161-104130
Scale 1:500

Drawing No. L100-003
3 of 8

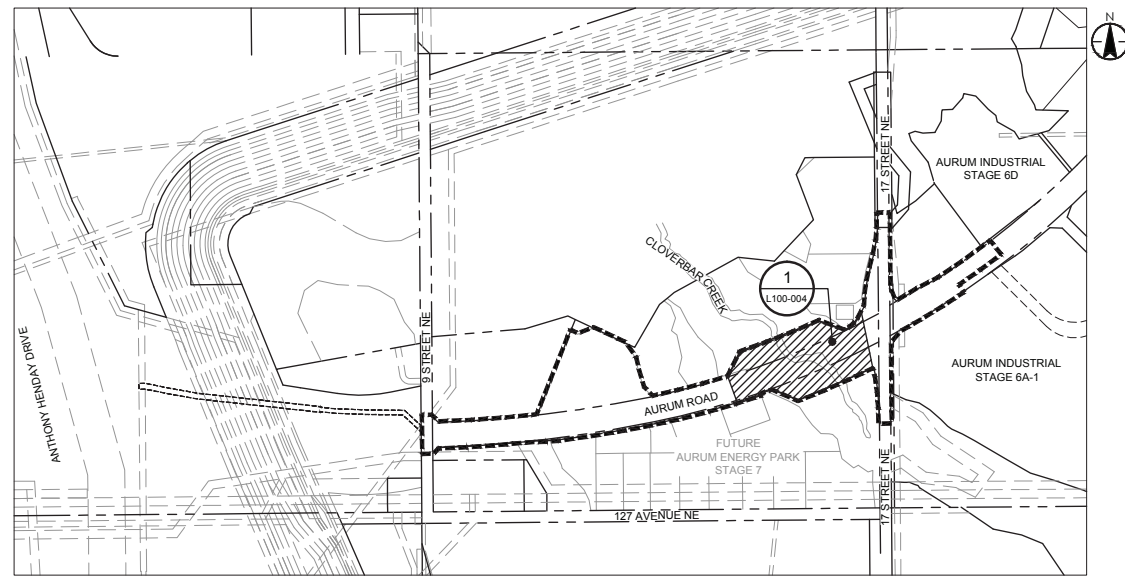

KEY PLAN
SCALE: N.T.S.

NOTES:

1. ALL DISTURBED AREAS TO BE TOPSOILED, HYDROSEEDED, AND PROTECTED WITH SC150NB EROSION CONTROL BLANKET, UNLESS OTHERWISE SPECIFIED.
2. ALL WATER COLLECTED WITHIN SEDIMENT FOREBAY A & D TO BE PUMPED OUT AFTER ANY STORM EVENT OR AS REQUIRED. WATER TO BE CLEAN AND FREE OF DEBRIS AND SUSPENDED SEDIMENTS PRIOR TO PUMPING. SKIMMERS AND FILTER BAGS WILL BE USED AS REQUIRED TO ENSURE NO SILTATION IN PUMP OUT LOCATION. CLEAN WATER TO BE PUMPED INTO NATURAL/VEGETATED AREAS ADJACENT TO SEDIMENT PONDS.
3. ALL WATER COLLECTED WITHIN SEDIMENT FOREBAY B, C, E, & F TO BE PUMPED OUT AFTER ANY STORM EVENT OR AS REQUIRED. WATER TO BE CLEAN AND FREE OF DEBRIS AND SUSPENDED SEDIMENTS PRIOR TO PUMPING. SKIMMERS AND FILTER BAGS WILL BE USED AS REQUIRED TO ENSURE NO SILTATION IN PUMP OUT LOCATION. CLEAN WATER TO BE PUMPED INTO NATURAL/VEGETATED AREAS ADJACENT TO SEDIMENT PONDS.

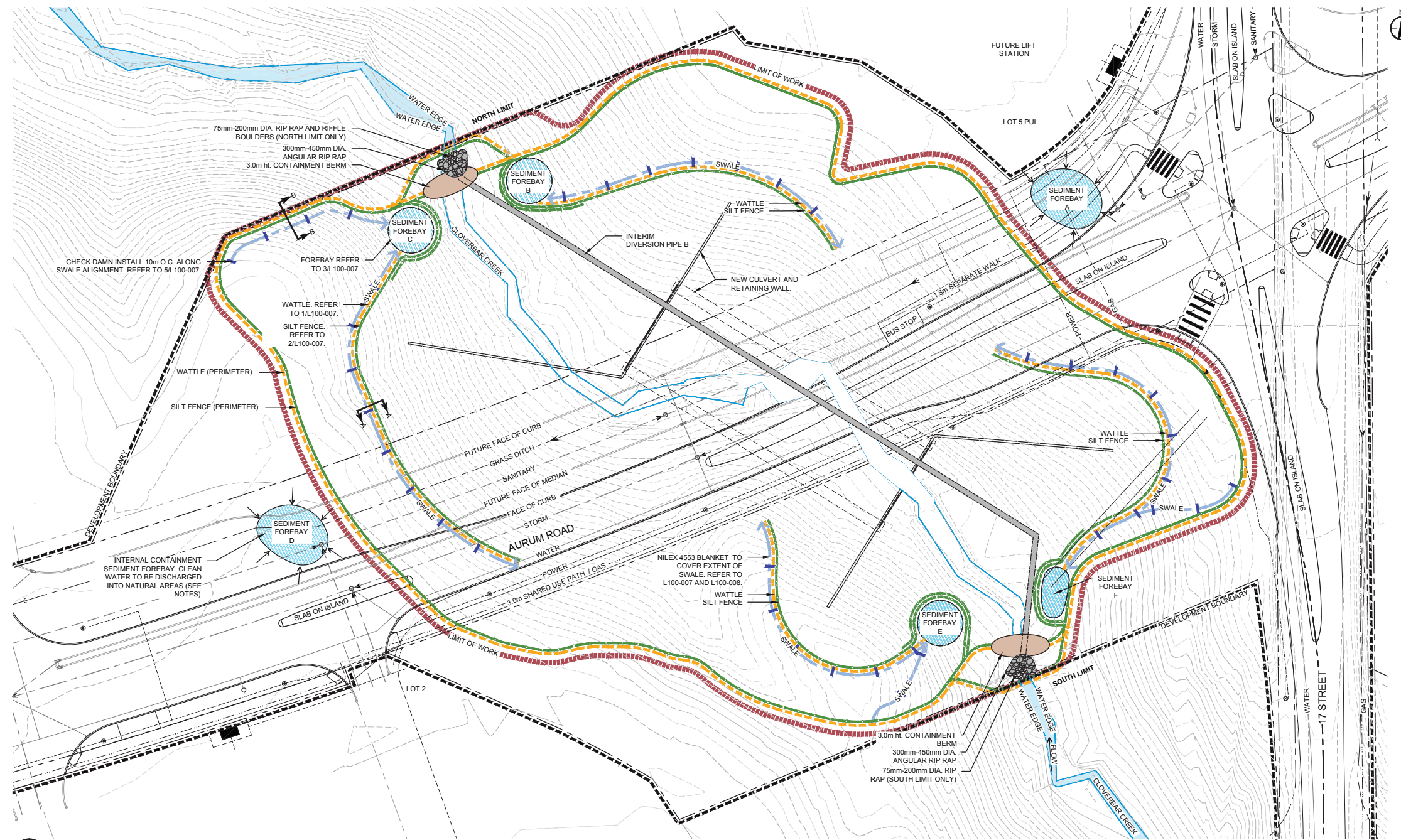

1 STAGE 4 ARCH CULVERT CONSTRUCTION - ESC REQUIREMENTS
SCALE: 1:500



Stantec Consulting Ltd.
10160 - 112 Street
Edmonton AB Canada
Tel. 780.917.7000
www.stantec.com

Copyright Reserved

The Contractor shall verify and be responsible for all dimensions. DO NOT scale the drawing - any errors or omissions shall be reported to Stantec without delay. The Copyrights to all designs and drawings are the property of Stantec. Reproduction or use for any purpose other than that authorized by Stantec is forbidden.

Legend

- MANHOLE
- LIGHT STANDARD
- ⊠ TELEPHONE / VIDEO PEDESTAL
- TRANSFORMER
- HYDRANT
- LIMIT OF WORK
- DEVELOPMENT BOUNDARY
- CHECK DAM
- SILT FENCE
- WATTLE
- EDGE OF WATER

Notes

UTILITY SETBACKS

LANDSCAPE CONTRACTOR TO CALL 'ALBERTA ONE-CALL' AT 1-800-242-3447 TO HAVE ALL EXISTING SITE UTILITIES LOCATED PRIOR TO CONSTRUCTION AND PLANT NO CLOSER THAN THE FOLLOWING DIMENSIONS FROM THE SERVICES:

1. 1.0m FROM POWER LINES
2. 3.5m FROM ALL POWER HARDWARE
3. 1.8m FROM WATER MAINS, WATER VALVES, MANUAL AIRVENTS, AND SERVICES
4. 2.0m FROM SEWER MAINS, AND MANHOLES
5. 1.8m FROM SEWER SERVICES
6. 1.5m FROM GAS (NO TREES WITHIN EASEMENT)
7. 7.5m FROM STREET CORNERS.
8. 3.5m FROM FIRE HYDRANTS.
9. 1.5m FROM DRIVEWAYS
10. 1.5m FROM ALLEY ACCESSES
11. 1.0m FROM SIDEWALKS
- OR AS PER APPROVED ENG. CROSS SECTIONS
12. 3.5m FROM TRANSIT ZONES
13. 3.0m FROM PRIVATE PROPERTY BOUNDARY
14. 1.25m FROM COLLECTOR ROAD CURB FACE
15. 1.25m FROM LOCAL ROAD CURB FACE
16. 2.0m FROM ARTERIAL ROAD CURB FACE
17. 3.5m FROM YIELD AND STOP SIGNS
18. 3.5m FROM BUS STOP SIGNS
19. 2.0m FROM ALL OTHER SIGNS
20. 1.0m FROM OTHER UNDERGROUND UTILITIES
21. 3.5m FROM TELUS PEDESTALS
22. 2.0m FROM TELUS DUCT STRUCTURE
23. 1.0m FROM TELUS CABLE FACILITIES

LANDSCAPE CONTRACTOR IS RESPONSIBLE FOR DAMAGES AND LIABILITIES INCURRED BY DAMAGES TO SITE UTILITIES.

Development Engineer, Sustainable Development			
Approvals			YY.MM.DD
Revision	By	Appd.	YY.MM.DD
1ST ISSUE FOR REVIEW	CM/KH/CB	DP	17.01.13
Issued	By	Appd.	YY.MM.DD
File Name: LA_AurumRainESC_recover.dwg	Dwn.	Chkd.	Dgnd.
			YY.MM.DD

Permit-Seal



David A. Price

Client/Project
AURUM INDUSTRIAL
DEVELOPMENT PARTNERSHIP
AURUM ROAD
17 STREET NE TO 9 STREET NE
Edmonton, AB

Title
STAGE 4
ARCH CULVERT CONSTRUCTION
ESC REQUIREMENTS

Project No. 1161-104130
Scale 1:500

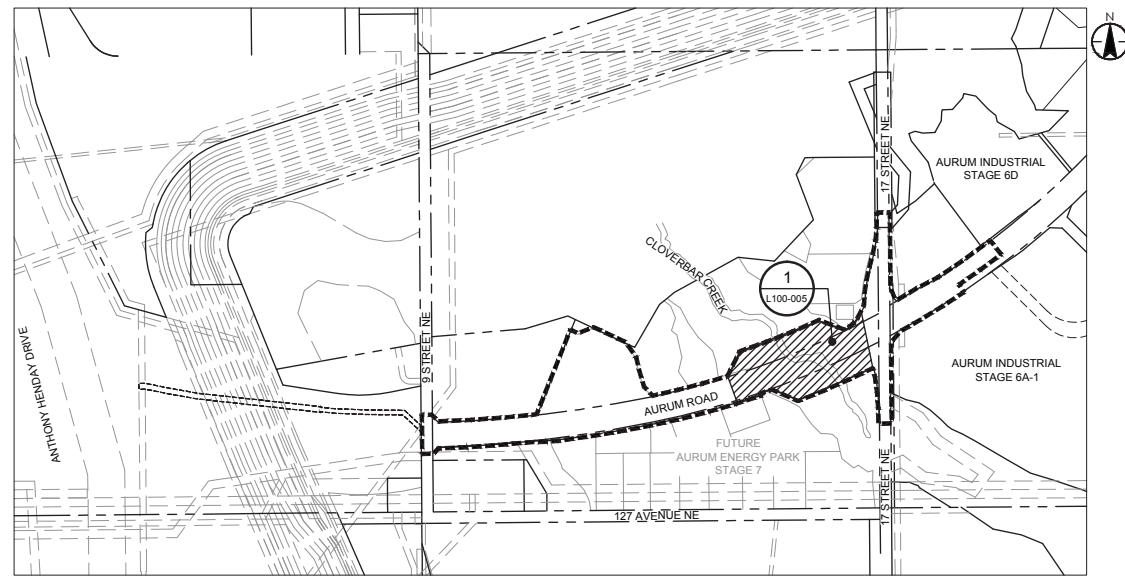

KEY PLAN
SCALE: N.T.S.

NOTES:

1. ALL DISTURBED AREAS TO BE TOPSOILED, HYDROSEED, AND PROTECTED WITH SC150NB EROSION CONTROL BLANKET, UNLESS OTHERWISE SPECIFIED.
2. ALL WATER COLLECTED WITHIN SEDIMENT FOREBAY A & D TO BE PUMPED OUT AFTER ANY STORM EVENT OR AS REQUIRED. WATER TO BE CLEAN AND FREE OF DEBRIS AND SUSPENDED SEDIMENTS PRIOR TO PUMPING. SKIMMERS AND FILTER BAGS WILL BE USED AS REQUIRED TO ENSURE NO SILTATION IN PUMP OUT LOCATION. CLEAN WATER TO BE PUMPED INTO NATURAL/VEGETATED AREAS ADJACENT TO SEDIMENT PONDS.
3. ALL WATER COLLECTED WITHIN SEDIMENT FOREBAY B, C, E, & F TO BE PUMPED OUT AFTER ANY STORM EVENT OR AS REQUIRED. WATER TO BE CLEAN AND FREE OF DEBRIS AND SUSPENDED SEDIMENTS PRIOR TO PUMPING. SKIMMERS AND FILTER BAGS WILL BE USED AS REQUIRED TO ENSURE NO SILTATION IN PUMP OUT LOCATION. CLEAN WATER TO BE PUMPED INTO NATURAL/VEGETATED AREAS ADJACENT TO SEDIMENT PONDS.

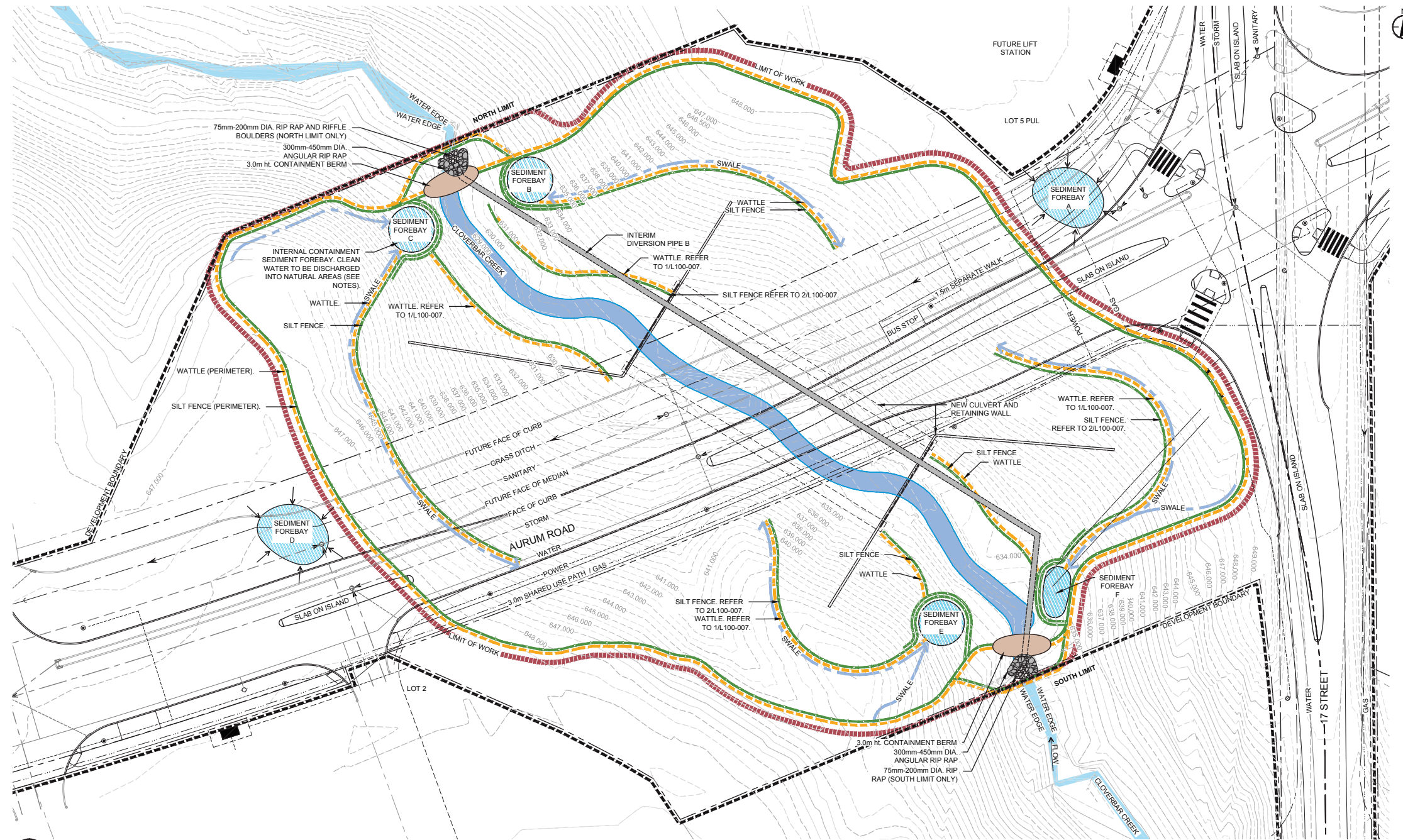

1 STAGE 5 CREEK RE-ALIGNMENT - ESC REQUIREMENTS
SCALE: 1:500



Stantec Consulting Ltd.
10160 - 112 Street
Edmonton AB Canada
Tel. 780.917.7000
www.stantec.com

Copyright Reserved

The Contractor shall verify and be responsible for all dimensions. DO NOT scale the drawing - any errors or omissions shall be reported to Stantec without delay. The Copyrights to all designs and drawings are the property of Stantec. Reproduction or use for any purpose other than that authorized by Stantec is forbidden.

Legend

- MANHOLE
- LIGHT STANDARD
- ⊠ TELEPHONE / VIDEO PEDESTAL
- TRANSFORMER
- HYDRANT
- LIMIT OF WORK
- DEVELOPMENT BOUNDARY
- EDGE OF WATER
- SILT FENCE
- WATTLE

Notes

UTILITY SETBACKS

LANDSCAPE CONTRACTOR TO CALL 'ALBERTA ONE-CALL' AT 1-800-242-3447 TO HAVE ALL EXISTING SITE UTILITIES LOCATED PRIOR TO CONSTRUCTION AND PLANT NO CLOSER THAN THE FOLLOWING DIMENSIONS FROM THE SERVICES:

1. 1.0m FROM POWER LINES
2. 3.5m FROM ALL POWER HARDWARE
3. 1.8m FROM WATER MAINS, WATER VALVES, MANUAL AIRVENTS, AND SERVICES
4. 2.0m FROM SEWER MAINS, AND MANHOLES
5. 1.8m FROM SEWER SERVICES
6. 1.5m FROM GAS (NO TREES WITHIN EASEMENT)
7. 7.5m FROM STREET CORNERS.
8. 3.5m FROM FIRE HYDRANTS.
9. 1.5m FROM DRIVEWAYS
10. 1.5m FROM ALLEY ACCESSES
11. 1.0m FROM SIDEWALKS
- OR AS PER APPROVED ENG. CROSS SECTIONS
12. 3.5m FROM TRANSIT ZONES
13. 3.0m FROM PRIVATE PROPERTY BOUNDARY
14. 1.25m FROM COLLECTOR ROAD CURB FACE
15. 1.25m FROM LOCAL ROAD CURB FACE
16. 2.0m FROM ARTERIAL ROAD CURB FACE
17. 3.5m FROM YIELD AND STOP SIGNS
18. 3.5m FROM BUS STOP SIGNS
19. 2.0m FROM ALL OTHER SIGNS
20. 1.0m FROM OTHER UNDERGROUND UTILITIES
21. 3.5m FROM TELUS PEDESTALS
22. 2.0m FROM TELUS DUCT STRUCTURE
23. 1.0m FROM TELUS CABLE FACILITIES

LANDSCAPE CONTRACTOR IS RESPONSIBLE FOR DAMAGES AND LIABILITIES INCURRED BY DAMAGES TO SITE UTILITIES.

Development Engineer, Sustainable Development			
Approvals			YY.MM.DD
Revision			YY.MM.DD
1ST ISSUE FOR REVIEW	CM/KH/CB	DP	17.01.13
Issued			YY.MM.DD
File Name: LA_AurumRainwESC_cover.dwg	Dwn.	Chkd.	Dgtr.
Permit-Seal			



David A. Price

Client/Project
AURUM INDUSTRIAL DEVELOPMENT PARTNERSHIP
AURUM ROAD
17 STREET NE TO 9 STREET NE
Edmonton, AB

Title
STAGE 5 CREEK RE-ALIGNMENT ESC REQUIREMENTS

Project No. 1161-104130
Scale 1:500

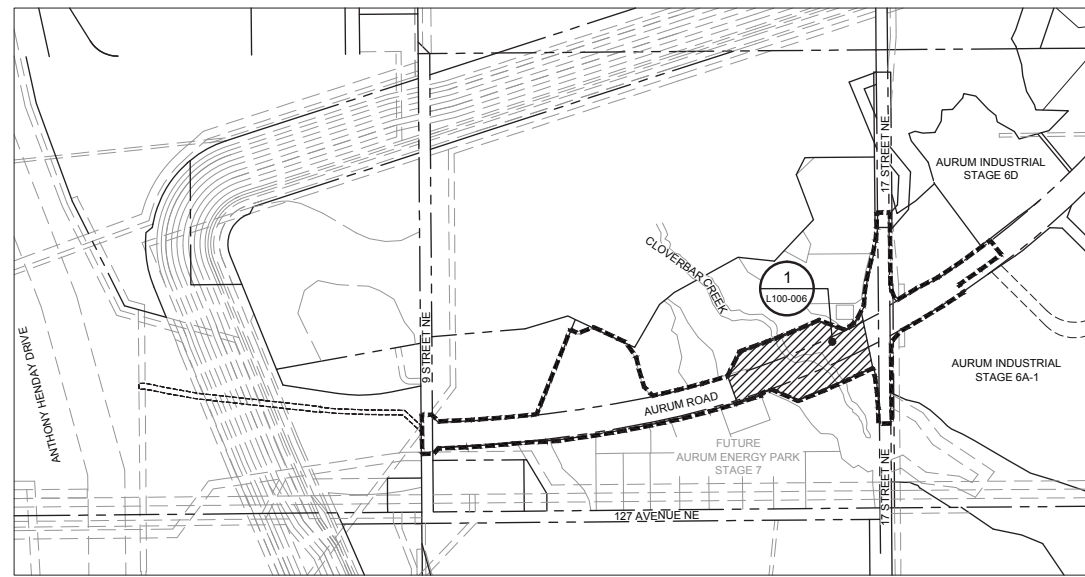

KEY PLAN
SCALE: N.T.S.

NOTES:

1. ALL DISTURBED AREAS TO BE TOPSOILED, HYDROSEEDED, AND PROTECTED WITH SC150NB EROSION CONTROL BLANKET, UNLESS OTHERWISE SPECIFIED.

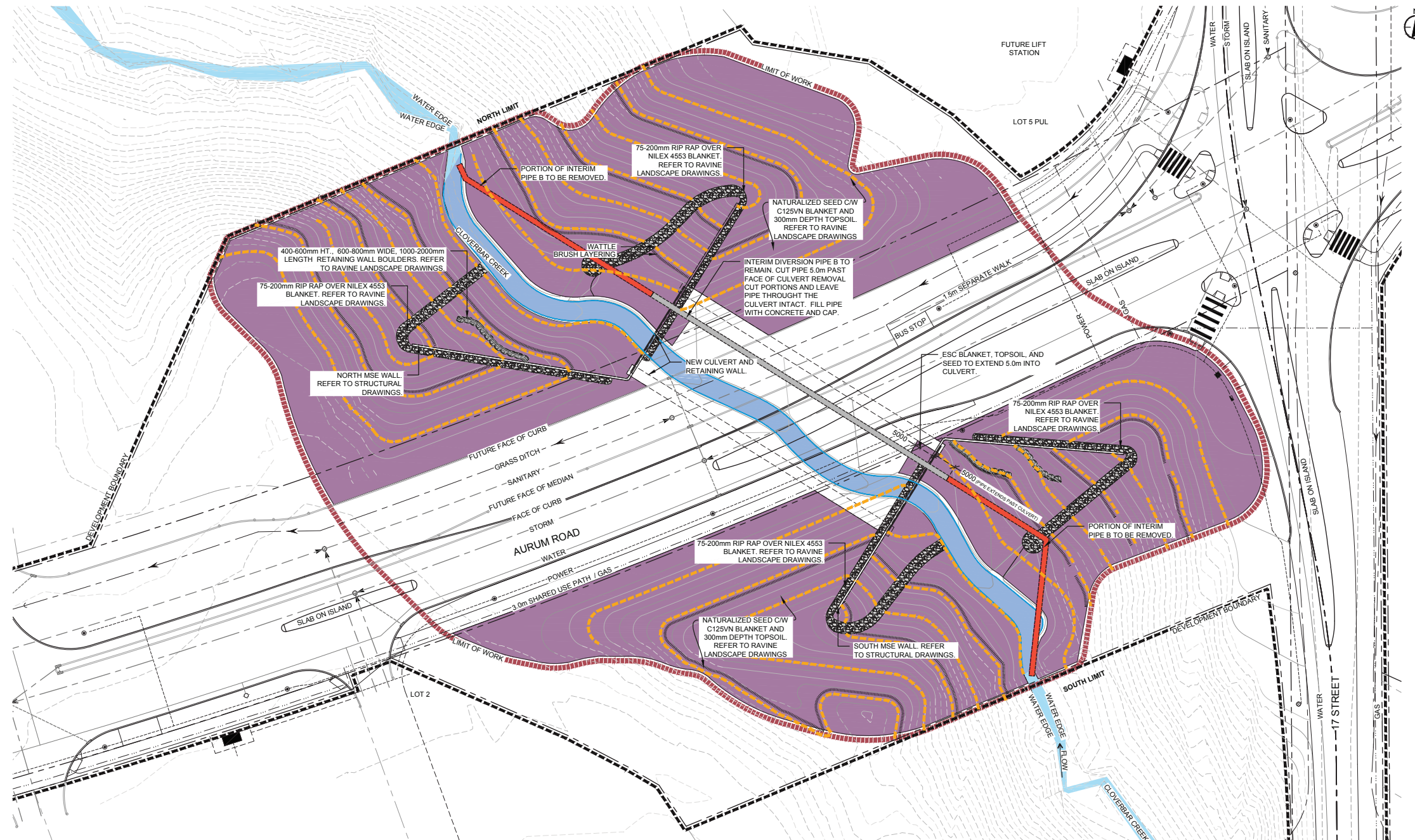

1 STAGE 6 FINAL SITE RESTORATION - ESC REQUIREMENTS
SCALE: 1:500



Stantec Consulting Ltd.
10160 - 112 Street
Edmonton AB Canada
Tel. 780.917.7000
www.stantec.com

Copyright Reserved
The Contractor shall verify and be responsible for all dimensions. DO NOT scale the drawing - any errors or omissions shall be reported to Stantec without delay. The Copyrights to all designs and drawings are the property of Stantec. Reproduction or use for any purpose other than that authorized by Stantec is forbidden.

- Legend**
- MANHOLE
 - ⊙ LIGHT STANDARD
 - ⊕ TELEPHONE / VIDEO PEDESTAL
 - TRANSFORMER
 - ⊕ HYDRANT
- LIMIT OF WORK
- - - DEVELOPMENT BOUNDARY
- - - BRUSH LAYERING
- - - EDGE OF WATER

- Notes**
- UTILITY SETBACKS**
- LANDSCAPE CONTRACTOR TO CALL 'ALBERTA ONE-CALL' AT 1-800-242-3447 TO HAVE ALL EXISTING SITE UTILITIES LOCATED PRIOR TO CONSTRUCTION AND PLANT NO CLOSER THAN THE FOLLOWING DIMENSIONS FROM THE SERVICES:
1. 1.0m FROM POWER LINES
 2. 3.5m FROM ALL POWER HARDWARE
 3. 1.8m FROM WATER MAINS, WATER VALVES, MANUAL AIRVENTS, AND SERVICES
 4. 2.0m FROM SEWER MAINS, AND MANHOLES
 5. 1.8m FROM SEWER SERVICES
 6. 1.5m FROM GAS (NO TREES WITHIN EASEMENT)
 7. 7.5m FROM STREET CORNERS.
 8. 3.5m FROM FIRE HYDRANTS.
 9. 1.5m FROM DRIVEWAYS
 10. 1.5m FROM ALLEY ACCESSSES
 11. 1.0m FROM SIDEWALKS
 - OR AS PER APPROVED ENG. CROSS SECTIONS
 12. 3.5m FROM TRANSIT ZONES
 13. 3.0m FROM PRIVATE PROPERTY BOUNDARY
 14. 1.25m FROM COLLECTOR ROAD CURB FACE
 15. 1.25m FROM LOCAL ROAD CURB FACE
 16. 2.0m FROM ARTERIAL ROAD CURB FACE
 17. 3.5m FROM YIELD AND STOP SIGNS
 18. 3.5m FROM BUS STOP SIGNS
 19. 2.0m FROM ALL OTHER SIGNS
 20. 1.0m FROM OTHER UNDERGROUND UTILITIES
 21. 3.5m FROM TELUS PEDESTALS
 22. 2.0m FROM TELUS DUCT STRUCTURE
 23. 1.0m FROM TELUS CABLE FACILITIES

LANDSCAPE CONTRACTOR IS RESPONSIBLE FOR DAMAGES AND LIABILITIES INCURRED BY DAMAGES TO SITE UTILITIES.

Development Engineer, Sustainable Development			
Approvals			YY.MM.DD
Revision	By	Appd.	YY.MM.DD
1ST ISSUE FOR REVIEW	CM/KH/CB	DP	17.01.13
Issued	By	Appd.	YY.MM.DD
File Name: LA_AurumRavineESC_cover.dwg	Dwn.	Chkd.	Dgtr.
Permit-Seal			



David A. Price

Client/Project
AURUM INDUSTRIAL DEVELOPMENT PARTNERSHIP

AURUM ROAD
17 STREET NE TO 9 STREET NE
Edmonton, AB

Title
STAGE 6 FINAL SITE RESTORATION ESC REQUIREMENTS

Project No. 1161-104130
Scale 1:500



STRAW WATTLE INSTALLATION GUIDE

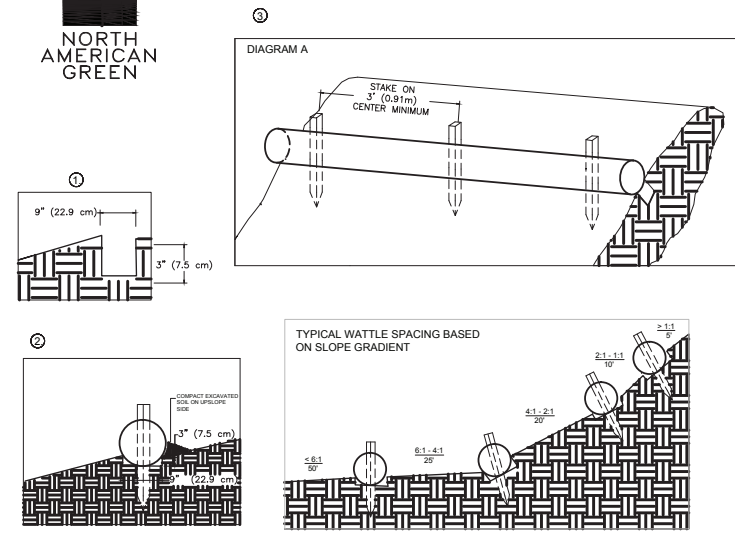

- BEGIN AT THE LOCATION WHERE THE WATTLE IS TO BE INSTALLED BY EXCAVATING A 2-3" (5-7.5 CM) DEEP X 9" (22.9 CM) WIDE TRENCH ALONG THE CONTOUR OF THE SLOPE. EXCAVATED SOIL SHOULD BE PLACED UPSLOPE FROM THE ANCHOR TRENCH.
- PLACE THE WATTLE IN THE TRENCH SO THAT IT CONTOURS TO THE SOIL SURFACE. COMPACT SOIL FROM THE EXCAVATED TRENCH AGAINST THE WATTLE ON THE UPSLOPE SIDE. ADJACENT WATTLES SHOULD TIGHTLY ADJUT.
- SECURE THE WATTLE WITH 18-24" (45-61 CM) STAKES EVERY 3-4' (0.9-1.2 M) AND WITH A STAKE ON EACH END. STAKES SHOULD BE DRIVEN THROUGH THE MIDDLE OF THE WATTLE LEAVING AT LEAST 2-3" (5-7.5 CM) OF STAKE EXTENDING ABOVE THE WATTLE. STAKES SHOULD BE DRIVEN PERPENDICULAR TO THE SLOPE FACE.

North American Green Straw Wattles are a Best Management Practice (BMP) that offers an effective and economical alternative to silt fence and straw bales for sediment control and storm water runoff.

Guidelines are provided to assist in design, installation, and structure spacing. The guidelines may require modification due to variation in soil type, rainfall intensity or duration, and amount of runoff affecting the application site.

To maximize sediment containment with the Straw Wattle, place the initial structure at the top/crest of the slope if significant runoff is expected from above. If no runoff from above is expected, the initial Straw Wattle can be installed at the appropriate distance downhill from the top/crest of the slope. The final structure should be installed at or just beyond the bottom/toe of the slope. Wattles should be installed perpendicular to the primary direction of overland flow.

Straw Wattles are a temporary sediment control device and are not intended to replace rolled erosion control products (RECPs) or hydraulic erosion control products (HECPs). If vegetation is desired for permanent erosion control, North American Green recommends that RECPs or HECPs be used to provide effective immediate erosion control until vegetation is established. Straw Wattles may be used in conjunction with blankets, mats, and mulches as supplemental sediment and runoff control for these applications. Like all sediment control devices, the effectiveness of the Straw Wattle is dependent on storage capacity.

14649 HIGHWAY 41 NORTH, EVANSVILLE, INDIANA 47725
1-800-772-2040 TOLL FREE 812-867-6632
www.nagreen.com

1 STRAW WATTLE TYP. INSTALLATION
SCALE: N.T.S.

- SILT FENCE NOTES**
- SILT FENCE TO BE INSPECTED MONTHLY AND AFTER ANY PRECIPITATION EXCEEDING 40mm OVER A 24 HOUR PERIOD.
 - FABRIC TO BE TRENCHED IN, TIGHT AND CONSISTENT BETWEEN ALL POSTS. ADD ADDITIONAL POSTS AS REQUIRED.
 - OVERALL FENCE INSTALLATION TO BE INSTALLED IN STRATEGIC SEMI-CIRCLES, WITH THE CROWN OF THE CURVE TO BE IN THE DIRECTION OF THE WATER FLOW. THE INTENT IS TO INCREASE STABILIZATION AND EFFECTIVENESS OF THE SILT FENCE.
 - AT FAC ALL POSTS TO BE REMOVED AND FABRIC TO BE CUT FLUSH WITH GROUND - DO NOT PULL FENCE FABRIC FROM TRENCH.
 - SEDIMENT TO BE REMOVED WHEN ACCUMULATION REACHES 50% OF FENCE HEIGHT.
 - SEDIMENT TO BE REMOVED TO AN OFFSITE LOCATION.

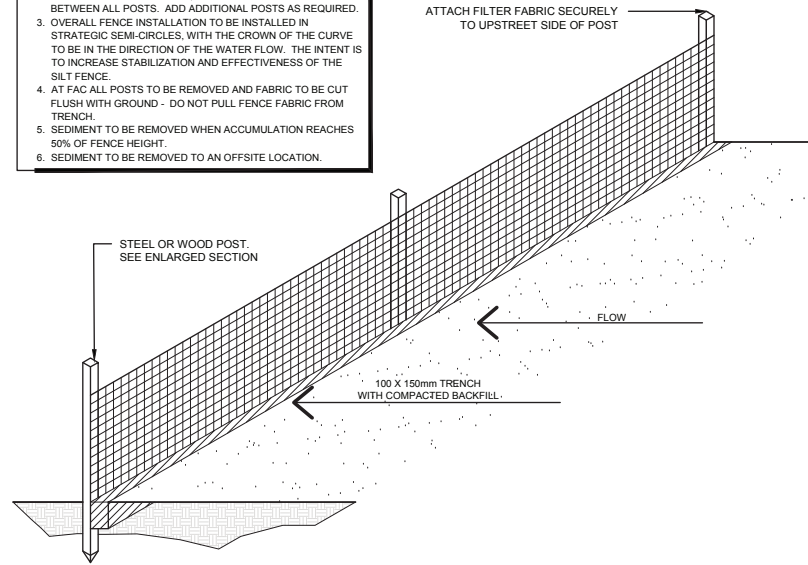

2 SILT FENCE INSTALLATION
SCALE: N.T.S.

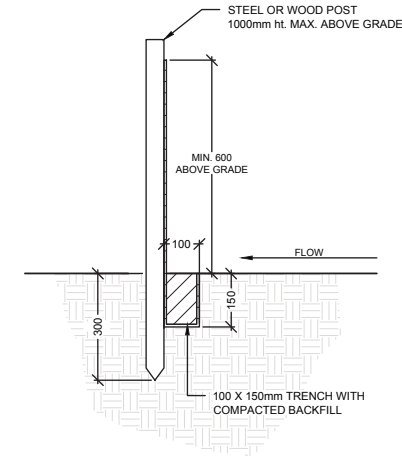

SECTION

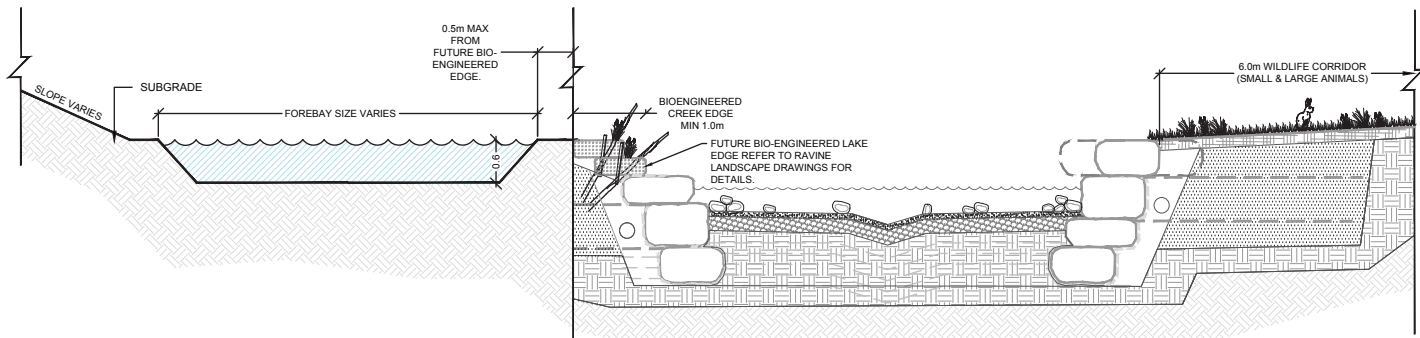

3 FOREBAY
SCALE: 1:50

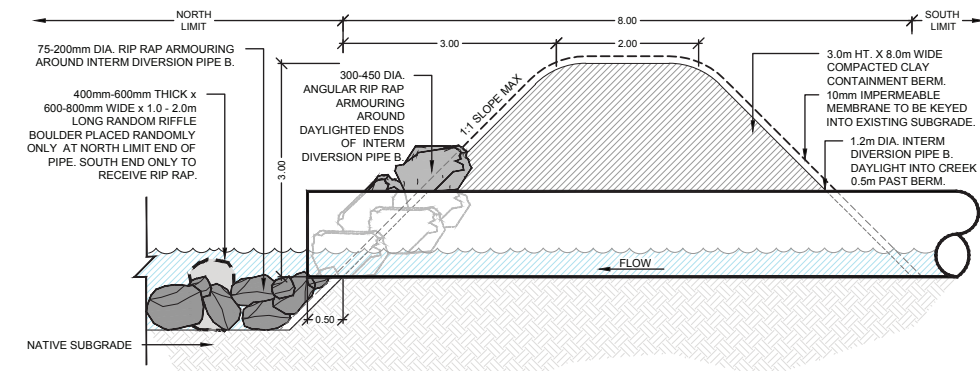

4 3.0m HT. CONTAINMENT BERM
SCALE: 1:50

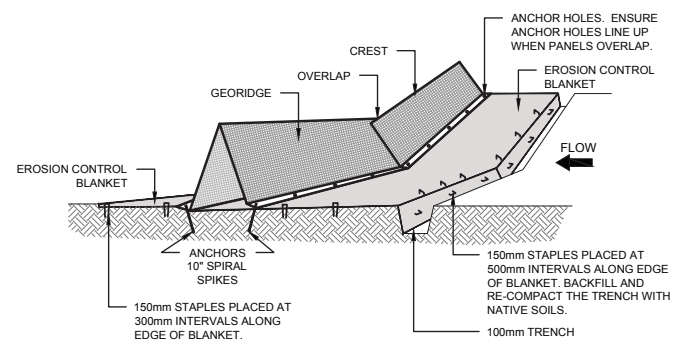

5 CHECK DAM
SCALE: 1:10

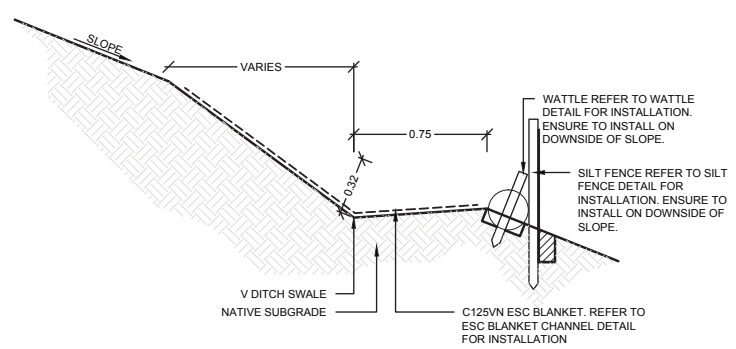

6 ESC SWALE ARMOURING
SCALE: 1:20

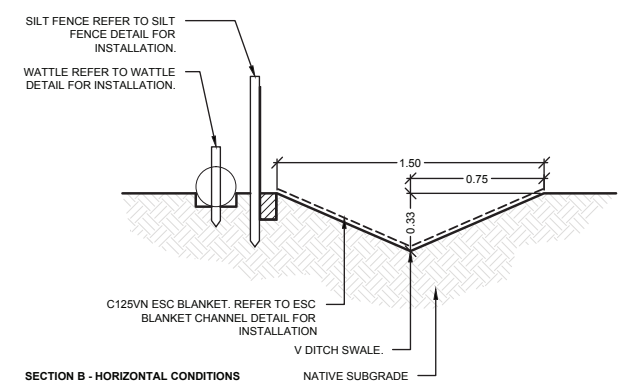

SECTION B - HORIZONTAL CONDITIONS



Stantec Consulting Ltd.
10160 - 112 Street
Edmonton AB Canada
Tel. 780.917.7000
www.stantec.com

Copyright Reserved

The Contractor shall verify and be responsible for all dimensions. DO NOT scale the drawing - any errors or omissions shall be reported to Stantec without delay. The Copyrights to all designs and drawings are the property of Stantec. Reproduction or use for any purpose other than that authorized by Stantec is forbidden.

Legend

Notes

Development Engineer, Sustainable Development			
Approvals			YY.MM.DD
Revision		By	Appd. YY.MM.DD
1ST ISSUE FOR REVIEW		CM/KH/CB	DP 17.01.13
Issued		By	Appd. YY.MM.DD
File Name:	LA_AurumRainwESC_recover.dwg	Dwn.	Chkd.
		Dgtr.	YY.MM.DD

Permit-Seal



David A. Price

Client/Project
AURUM INDUSTRIAL
DEVELOPMENT PARTNERSHIP
AURUM ROAD
17 STREET NE TO 9 STREET NE
Edmonton, AB

Title
ESC DETAILS

Project No. 1161-104130
Scale AS SHOWN

V:\1161\active\1161104130\drawing_Landscape\Aurum Road\LA_AurumRainwESC_recover.dwg
2017-1-13 10:57am BY: NHALONEN 7 of 8
Drawing No. L100-007

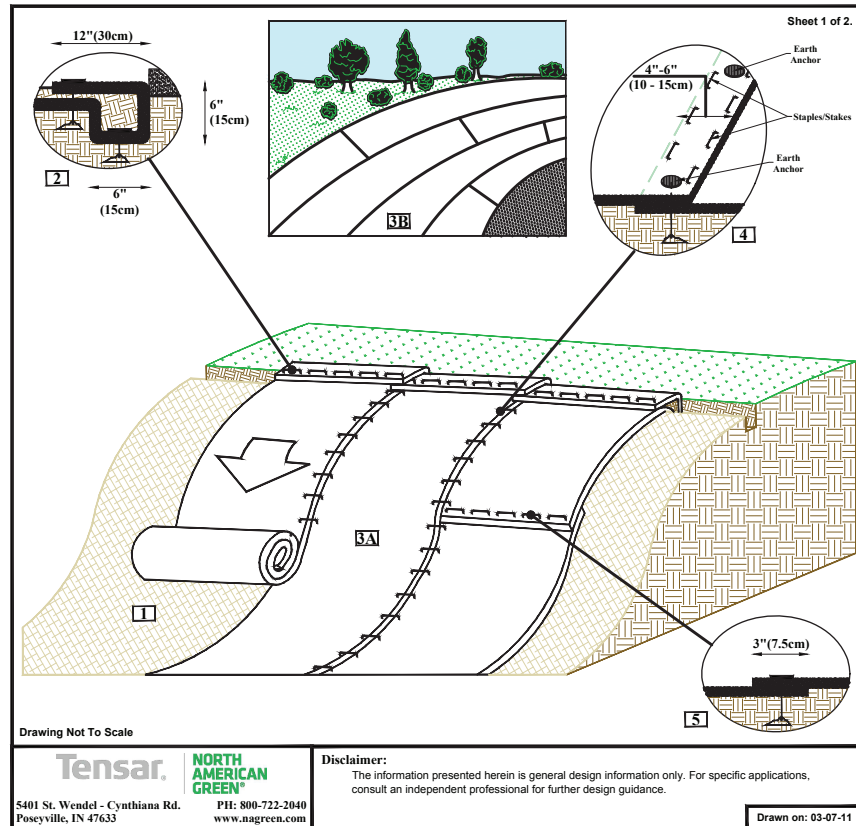

SLOPE INSTALLATION EARTH ANCHOR (EA) DETAIL

1. Prepare soil before installing high-performance turf reinforcement mats (HP-TRMs), including any necessary application of lime, fertilizer, and seed.
2. Begin at the top of the slope by anchoring the HP-TRMs in a 6" (15 cm) deep x 6" (15cm) wide trench with approximately 12" (30 cm) of HP-TRMs extended beyond the up-slope portion of the trench. Anchor the HP-TRMs with a row of staples and anchors approximately 12" (30 cm) apart in the bottom of the trench. Backfill and compact the trench after stapling. Apply seed to compacted soil and fold remaining 12" (30 cm) portion of HP-TRMs back over seed and compacted soil. Secure HP-TRMs over compacted soil with a row of staples/stakes spaced approximately 12" (30 cm) apart across the width of the HP-TRMs.
3. Roll the HP-TRMs (A) down or (B) horizontally across the slope. HP-TRMs will unroll with appropriate side against the soil surface. All HP-TRMs must be securely fastened to soil surface by placing staples/stakes in appropriate locations as shown in the staple pattern guide.
4. The edges of parallel HP-TRMs must be stapled with approximately 2" (5-12.5cm) overlap depending on the HP-TRM type.
5. Consecutive HP-TRMs spliced down the slope must be end over end (Shingle style) with an approximate 3"(7.5cm) overlap. Staple through overlapped area, approximately 12"(30cm) apart across entire HP-TRM width.

NOTE:
In loose soil conditions, the use of staple or stake lengths greater than 6"(15cm) may be necessary to properly secure the HP-TRMs.

Disclaimer:
The information presented herein is general design information only. For specific applications, consult an independent professional for further design guidance.

5401 St. Wendel - Cynthia Rd. Poseyville, IN 47633
PH: 800-722-2040 www.nagreen.com
Drawn on: 03-07-11

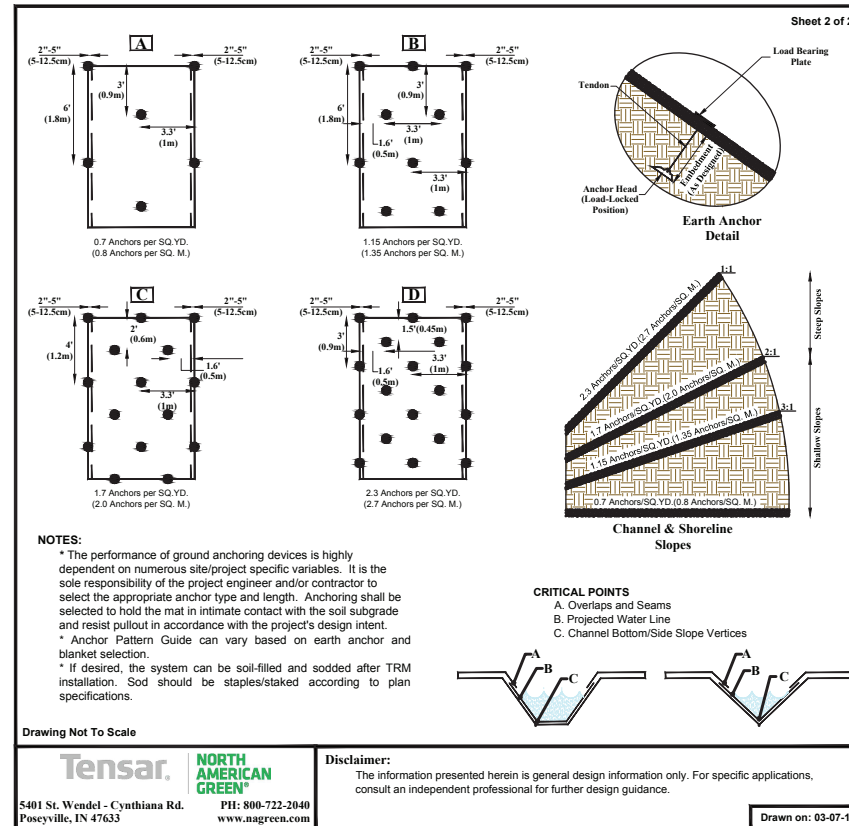

SLOPE INSTALLATION EARTH ANCHOR (EA) DETAIL

1. Prepare soil before installing high-performance turf reinforcement mats (HP-TRMs), including any necessary application of lime, fertilizer, and seed.
2. Begin at the top of the slope by anchoring the HP-TRMs in a 6" (15 cm) deep x 6" (15cm) wide trench with approximately 12" (30 cm) of HP-TRMs extended beyond the up-slope portion of the trench. Anchor the HP-TRMs with a row of staples and anchors approximately 12" (30 cm) apart in the bottom of the trench. Backfill and compact the trench after stapling. Apply seed to compacted soil and fold remaining 12" (30 cm) portion of HP-TRMs back over seed and compacted soil. Secure HP-TRMs over compacted soil with a row of staples/stakes spaced approximately 12" (30 cm) apart across the width of the HP-TRMs.
3. Roll the HP-TRMs (A) down or (B) horizontally across the slope. HP-TRMs will unroll with appropriate side against the soil surface. All HP-TRMs must be securely fastened to soil surface by placing staples/stakes in appropriate locations as shown in the staple pattern guide.
4. The edges of parallel HP-TRMs must be stapled with approximately 2" (5-12.5cm) overlap depending on the HP-TRM type.
5. Consecutive HP-TRMs spliced down the slope must be end over end (Shingle style) with an approximate 3"(7.5cm) overlap. Staple through overlapped area, approximately 12"(30cm) apart across entire HP-TRM width.

NOTE:
In loose soil conditions, the use of staple or stake lengths greater than 6"(15cm) may be necessary to properly secure the HP-TRMs.

Disclaimer:
The information presented herein is general design information only. For specific applications, consult an independent professional for further design guidance.

5401 St. Wendel - Cynthia Rd. Poseyville, IN 47633
PH: 800-722-2040 www.nagreen.com
Drawn on: 03-07-11

1 NILEX 4553 AND C125VN SLOPE AND ANCHOR INSTALLATION
SCALE: N.T.S.

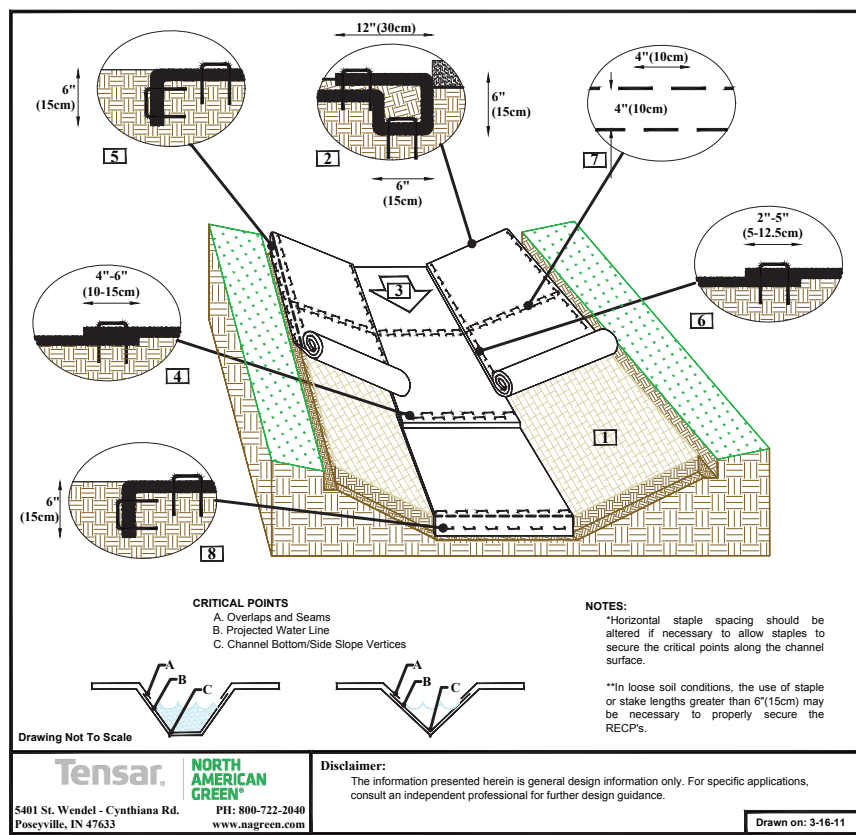

CHANNEL INSTALLATION DETAIL

1. Prepare soil before installing rolled erosion control products (RECPs), including any necessary application of lime, fertilizer, and seed.
2. Begin at the top of the channel by anchoring the RECPs in a 6" (15cm) deep x 6" (15cm) wide trench with approximately 12" (30cm) of RECPs extended beyond the up-slope portion of the trench. Use ShoreMax mat at the channel/curb outlet as supplemental scour protection as needed. Anchor the RECPs with a row of staples/stakes approximately 12" (30cm) apart in the bottom of the trench. Backfill and compact the trench after stapling. Apply seed to the compacted soil and fold the remaining 12" (30cm) portion of RECPs back over the seed and compacted soil. Secure RECPs over compacted soil with a row of staples/stakes spaced approximately 12" apart across the width of the RECPs.
3. Roll center RECPs in direction of water flow in bottom of channel. RECPs will unroll with appropriate side against the soil surface. All RECPs must be securely fastened to soil surface by placing staples/stakes in appropriate locations as shown in the staple pattern guide.
4. Place consecutive RECPs end-over-end (Shingle style) with a 4"-6" overlap. Use a double row of staples staggered 4" apart and 4" on center to secure RECPs.
5. Full length edge of RECPs at top of side slopes must be anchored with a row of staples/stakes approximately 12"(30cm) apart in a 6"(15cm) deep x 6"(15cm) wide trench. Backfill and compact the trench after stapling.
6. Adjacent RECPs must be overlapped approximately 2"-5" (5-12.5cm) (Depending on RECPs type) and stapled.
7. In high flow channel applications a staple check slot is recommended at 30 to 40 foot (9-12m) intervals. Use a double row of staples staggered 4"(10cm) apart and 4"(10cm) on center over entire width of the channel.
8. The terminal end of the RECPs must be anchored with a row of staples/stakes approximately 12" (30cm) apart in a 6"(15cm) deep x 6"(15cm) wide trench. Backfill and compact the trench after stapling.

CRITICAL POINTS
A. Overlaps and Seams
B. Projected Water Line
C. Channel Bottom/Side Slope Vertices

NOTES:
Horizontal staple spacing should be altered if necessary to allow staples to secure the critical points along the channel surface.
**In loose soil conditions, the use of staple or stake lengths greater than 6"(15cm) may be necessary to properly secure the RECPs.

Disclaimer:
The information presented herein is general design information only. For specific applications, consult an independent professional for further design guidance.

5401 St. Wendel - Cynthia Rd. Poseyville, IN 47633
PH: 800-722-2040 www.nagreen.com
Drawn on: 3-16-11

2 NILEX 4553 AND C125VN CHANNEL INSTALLATION
SCALE: N.T.S.



Stantec Consulting Ltd.
10160 - 112 Street
Edmonton AB Canada
Tel. 780.917.7000
www.stantec.com

Copyright Reserved
The Contractor shall verify and be responsible for all dimensions. DO NOT scale the drawing - any errors or omissions shall be reported to Stantec without delay. The Copyrights to all designs and drawings are the property of Stantec. Reproduction or use for any purpose other than that authorized by Stantec is forbidden.

Legend

Notes

Development Engineer, Sustainable Development			
Approvals			YY.MM.DD
Revision	By	Appd.	YY.MM.DD
1ST ISSUE FOR REVIEW	KM/KH/CB	DP	17.01.13
Issued	By	Appd.	YY.MM.DD
File Name:	LA_AurumRavineESC_cover.dwg	Dwn.	Chkd.
Permit-Seal		Dgtr.	YY.MM.DD

The Alberta Association of Landscape Architects

David A. Price

Client/Project

AURUM INDUSTRIAL DEVELOPMENT PARTNERSHIP

AURUM ROAD
17 STREET NE TO 9 STREET NE
Edmonton, AB

Title

ESC DETAILS

Project No. 1161-104130

Scale AS SHOWN

Project No. 1161-104130

Scale AS SHOWN

V:\1161\Active\1161104130\drawing_Landscape\Aurum Road\LA_AurumRavineESC_cover.dwg

2017-1-13 10:58am BY: NHALONEN 8 of 8

Drawing No. L100-008

APPENDIX G
CLOVER BAR CREEK CROSSING AT
AURUM ROAD: EVALUATION OF WILDLIFE
PASSAGE

**Clover Bar Creek Crossing at
Aurum Road: Evaluation of
Wildlife Passage**



Prepared for:
Aurum Industrial Development
Partnership

Prepared by:
Stantec Consulting Ltd
Edmonton, Alberta

December 2016

December 2016

Table of Contents

1.0	BACKGROUND	2
2.0	OBJECTIVES	2
3.0	WILDLIFE USE	2
3.1	OCCURRENCE.....	2
3.2	REGIONAL CONNECTIVITY.....	3
3.3	COLLISION MORTALITY.....	3
4.0	PROPOSED WILDLIFE CROSSING STRUCTURE	4
4.1	STRUCTURAL ATTRIBUTES OF THE WILDLIFE CROSSING STRUCTURE.....	4
4.1.1	Overall Design.....	4
4.1.2	Openness Index.....	8
4.1.3	Line-of-Sight.....	8
4.2	DESIGN ELEMENTS FOR LARGE, MEDIUM, AND SMALL TERRESTRIAL ANIMALS, AND GROUND-DWELLING BIRDS.....	9
4.2.1	Wildlife Path.....	9
4.2.2	Wildlife Exclusion Fencing.....	13
4.2.3	Landscaping.....	13
4.2.4	Lighting.....	13
4.2.5	Noise.....	13
4.2.6	Conclusion.....	14
4.3	DESIGN ELEMENTS FOR AMPHIBIANS AND AQUATIC SPECIES.....	14
4.4	DESIGN ELEMENTS FOR AERIAL MAMMALS, SCAVENGER BIRDS, BIRDS OF PREY, WATER BIRDS, AND OTHER BIRDS.....	15
5.0	CLOSURE	15
6.0	REFERENCES	16

LIST OF FIGURES

FIGURE 1	DRAFT PLAN OF THE LARGE WILDLIFE CROSSING STRUCTURE (S001-001, 5 DEC 2016).....	3
FIGURE 2	DRAFT SIDE ELEVATION OF LARGE WILDLIFE CROSSING STRUCTURE (S001-001, 5 DEC 2016).....	4
FIGURE 3.	MSE WALLS AND ENTRANCES TO THE WILDLIFE CROSSING STRUCTURE (S001-004, 5 DEC 2016).....	5
FIGURE 4	ESTIMATED LINE-OF-SIGHT THROUGH THE CONCRETE ARCH WILDLIFE CROSSING STRUCTURE AT AURUM ROAD.....	8
FIGURE 5	LANDSCAPING CONCEPT PLAN (S001-001, 5 DEC 2016).....	9
FIGURE 6	CREEK ALIGNMENT LANDSCAPE PLAN SHOWING LOCATION OF BRUSH PILES (L001-001, 15 DEC 2016).....	10

December 2016

1.0 BACKGROUND

Stantec Consulting Ltd. (Stantec) was retained by Aurum Industrial Development Partnership (the Client) to provide environmental consulting services and recommendations for wildlife passage as part of the Aurum Road crossing of Clover Bar Creek (the Project). To minimize the impacts on wildlife movement from transportation infrastructure, the City of Edmonton commissioned the development of the Wildlife Passage Engineering Design Guidelines (WPEDG; City of Edmonton 2010). The objective of these guidelines is to reduce human-wildlife conflict through improved awareness, safety, and collision reduction while also aiding in the maintenance of wildlife habitat connectivity and reduced genetic isolation. Stantec used these guidelines to design a wildlife crossing structure that reduces potential adverse effects of the Project on wildlife movement patterns.

As part of the Aurum Industrial Development, Aurum Road will be developed into to a 6-lane arterial roadway. This new roadway has the potential to create a barrier effect on wildlife. For this reason, and to reduce the potential for animal-vehicle collisions, provisions for wildlife movement where Aurum Road crosses the Clover Bar Creek ravine were developed.

The current design for the proposed new road development over Clover Bar Creek includes a large bottomless-arch multi-plate culvert (21 m wide x 8 m high x 67 m long) to accommodate the creek, along with aquatic and terrestrial wildlife species that occur in the area.

2.0 OBJECTIVES

The objective of this report is to evaluate the potential for the proposed wildlife crossing structure to facilitate passage of Ecological Design Groups (EDGs; groupings of species that share characteristics that should be considered in wildlife passage planning and design) predicted to occur in the area.

3.0 WILDLIFE USE

This section briefly discusses wildlife use from three perspectives: occurrence, regional connectivity, and collision mortality

3.1 OCCURRENCE

Spencer Environmental (2014) conducted snow-tracking and remote camera surveys in January, February, and March 2014 and identified eight species of wintering mammals and birds in the Project area, as follows:

- White-tailed deer (*Odocoileus virginianus*)

December 2016

- Coyote (*Canis latrans*)
- Snowshoe hare (*Lepus americanus*)
- Red squirrel (*Tamiasciurus hudsonicus*)
- Porcupine (*Erethizon dorsatum*)
- Weasel (*Mustela* sp.)
- Black-billed magpie (*Pica hudsonia*)
- Common raven (*Corvus corax*)

There are 11 EDGs (City of Edmonton 2010): Large Terrestrial, Medium Terrestrial, Small Terrestrial, Amphibians, Aerial Mammals, Aquatic Species, Scavenger Birds, Birds of Prey, Water Birds, Ground Dwelling Birds, and Other Birds. Since one or more species within all 11 EDGs are expected to occur in the deciduous woodlands, open grassy and shrubby habitats, and wetlands in the Project area, all 11 groups are considered target EDGs for this Project.

3.2 REGIONAL CONNECTIVITY

Clover Bar Creek is a southern tributary of the North Saskatchewan River and Clover Bar Ravine is identified as a Natural Linkage within the City of Edmonton's ecological network (Spencer Environmental 2014). The ravine functions as a wildlife movement corridor that extends from the North Saskatchewan River Valley to as far south as Yellowhead Highway.

Human disturbance has substantially modified the surrounding area, including industrial developments and transportation infrastructure. A potential barrier to wildlife movement exists along Clover Bar Ravine immediately south of the Project area where multiple CN Rail lines intersect the ravine. Areas further south of Yellowhead Highway are predominantly comprised of extensive industrial development. Connectivity to the North Saskatchewan River Valley is also subject to ongoing industrial development, potentially limiting wildlife movement.

3.3 COLLISION MORTALITY

Information regarding collision with vehicles is available for the Large Terrestrial EDG from field study and modelling.

Deer-vehicle collision (DVC) data collected between 2002 and 2007 (Found and Boyce 2011) indicate that up to four collisions were recorded during the survey period at Clover Bar Ravine just south of the Project area. Additionally, modeling of deer-wildlife collision potential in the area indicates that DVC potential is relatively high to the north of the Project area and moderate to moderately-low within Clover Bar Ravine (Found and Boyce 2011).

December 2016

4.0 PROPOSED WILDLIFE CROSSING STRUCTURE

This section provides details on the crossing engineering design (Section 4.1) followed by discussion of details specific to certain EDGs: Section 4.2 for Large Terrestrial, Medium Terrestrial, Small Terrestrial, Ground-dwelling Birds, Amphibians, and Aquatic Species; Section 4.3 for Amphibians and Aquatic Species; and, Section 4.4 for Aerial Mammals, Scavenger Birds, Birds of Prey, Water Birds, and Other Birds.

4.1 STRUCTURAL ATTRIBUTES OF THE WILDLIFE CROSSING STRUCTURE

4.1.1 Overall Design

The current design (December 2016) for the concrete arch culvert has openings that are 21 m wide and 8 m high, and a cross-sectional area of 132 m² (Figure 1, Figure 2, and Figure 3). The total length of the structure is 67 m (Figure 1 and Figure 2). The design of this wildlife crossing structure also includes wing-walls at either end to minimize the total footprint, minimize the length of the structure, and help guide animals to the entrances (Figure 1). These wing-walls will be constructed from mechanically stabilized earth (MSE).

This type of large underpass structure has been shown to be effective for both large wildlife (e.g., deer) and a variety of smaller species (Ruediger and DiGiorgio 2007). The type of wildlife crossing structure is considered a "Class 3 Large Underpass" within Kintsch and Cramer's (2011) *Passage Assessment System* and has the potential to provide passage for the species movement guilds that include the target EDGs at this site. Clevenger and Huijser (2011) have similar species guilds to Kintsch and Cramer (2011), and their "underpass with waterflow" design type has recommended dimensions of >4 m high with a wildlife path >3 m wide. The dimensions of the proposed arch culvert is within the large animal design recommendations for width (>12 m; Clevenger and Huijser 2011), and height (>4 m; Clevenger and Huijser 2011), but not length (<37 m; Cramer 2012).

The length of the structure (67 m) is determined by the width of the paved surface of Aurum Road and the 35-degree skew angle required to follow the orientation of Clover Bar Ravine. Although the 35-degree skew angle increases the overall length of the structure, this potential adverse effect on wildlife permeability was mitigated by increasing the size of the opening to achieve an openness index of 2.0 (see Section 4.1.1 below). This skew angle also improves line-of-sight through the structure (see Section 4.1.2 below), reduces the overall footprint of the Project, and reduces construction disturbance to the banks of Clover Bar Ravine.

CLOVER BAR CREEK CROSSING AT AURUM ROAD: EVALUATION OF WILDLIFE PASSAGE

December 2016

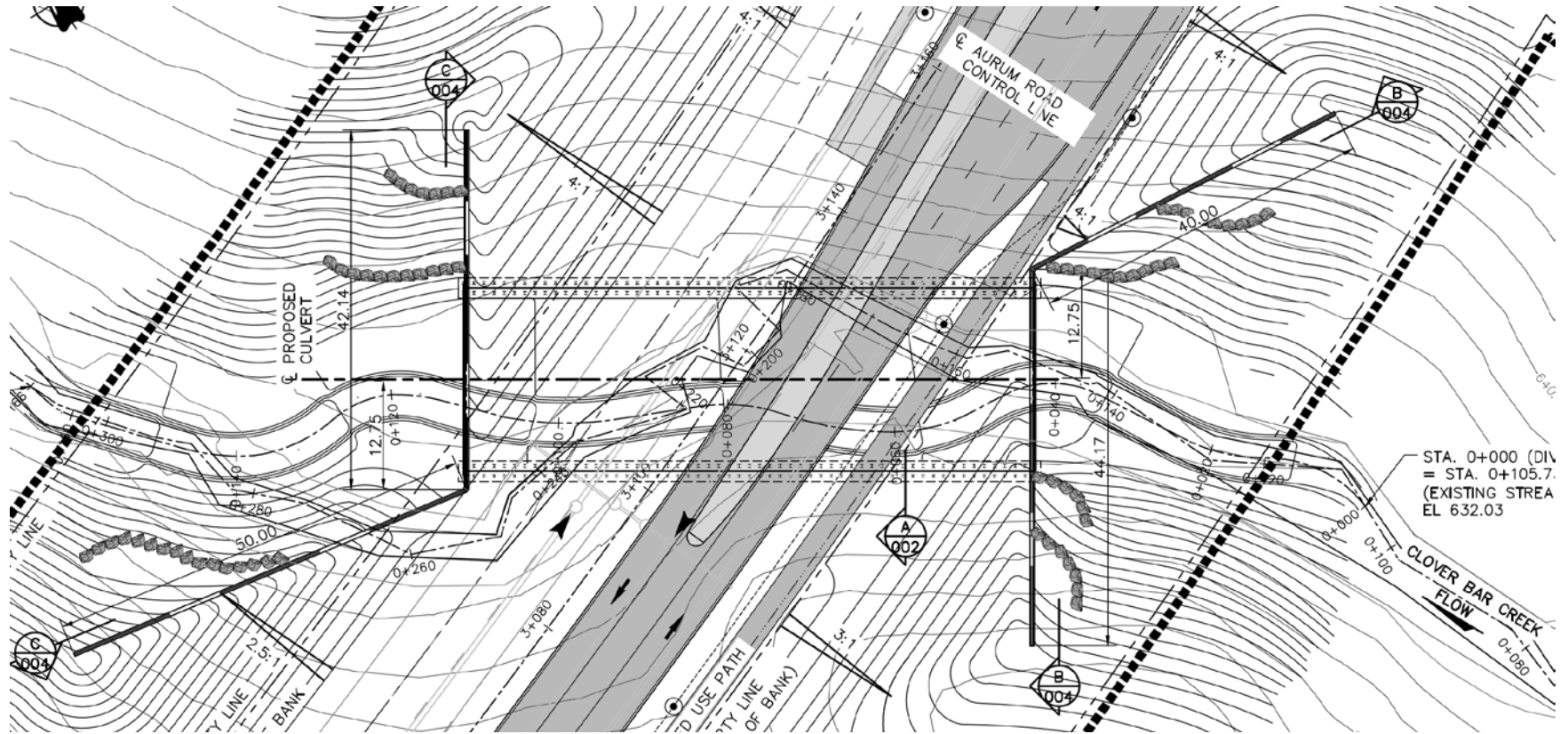

Figure 1 Draft Plan of the Large Wildlife Crossing Structure (S001-001, 5 Dec 2016)

CLOVER BAR CREEK CROSSING AT AURUM ROAD: EVALUATION OF WILDLIFE PASSAGE

December 2016

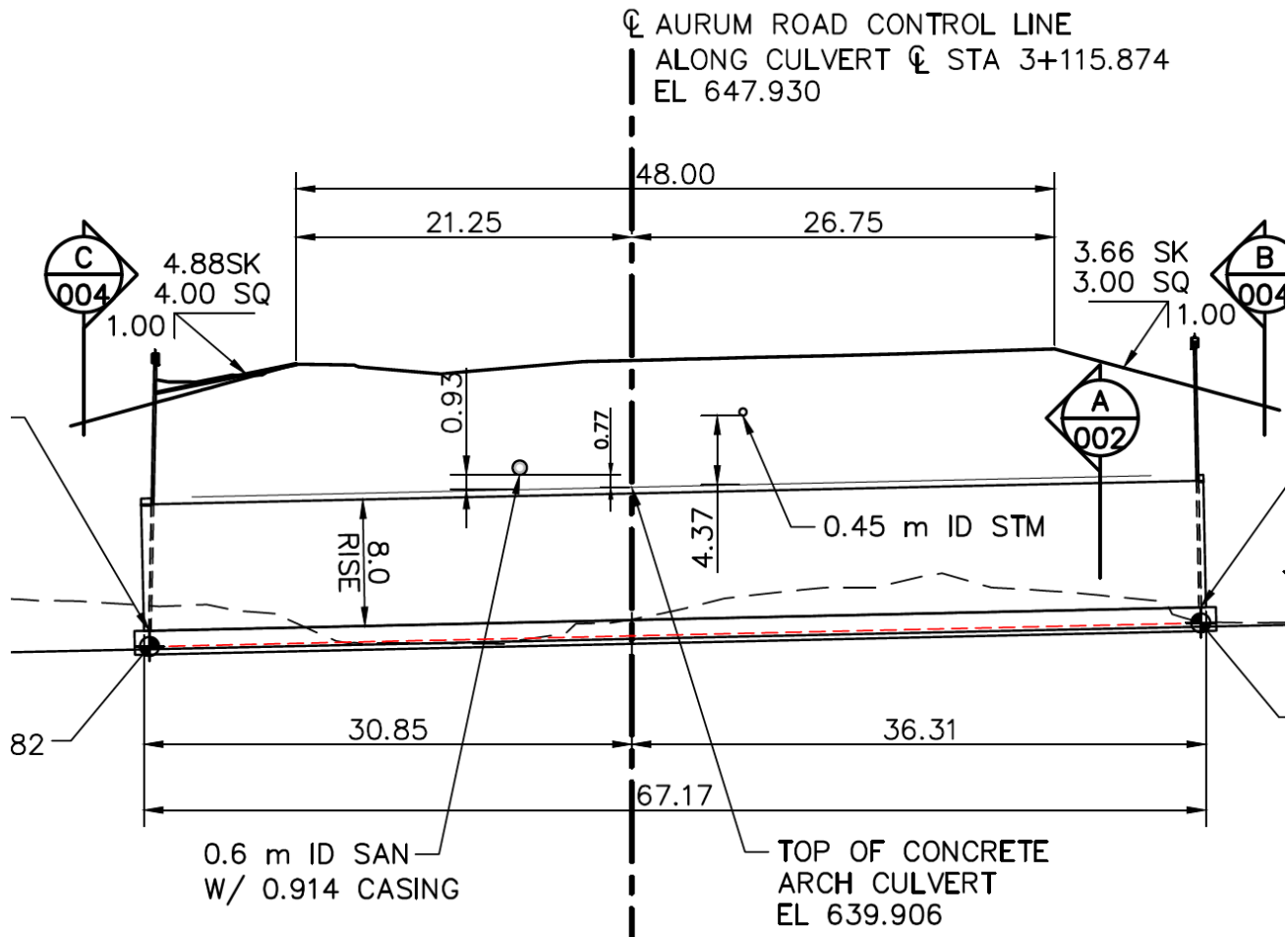

Figure 2 Draft Side Elevation of Large Wildlife Crossing Structure (S001-001, 5 Dec 2016)

CLOVER BAR CREEK CROSSING AT AURUM ROAD: EVALUATION OF WILDLIFE PASSAGE

December 2016

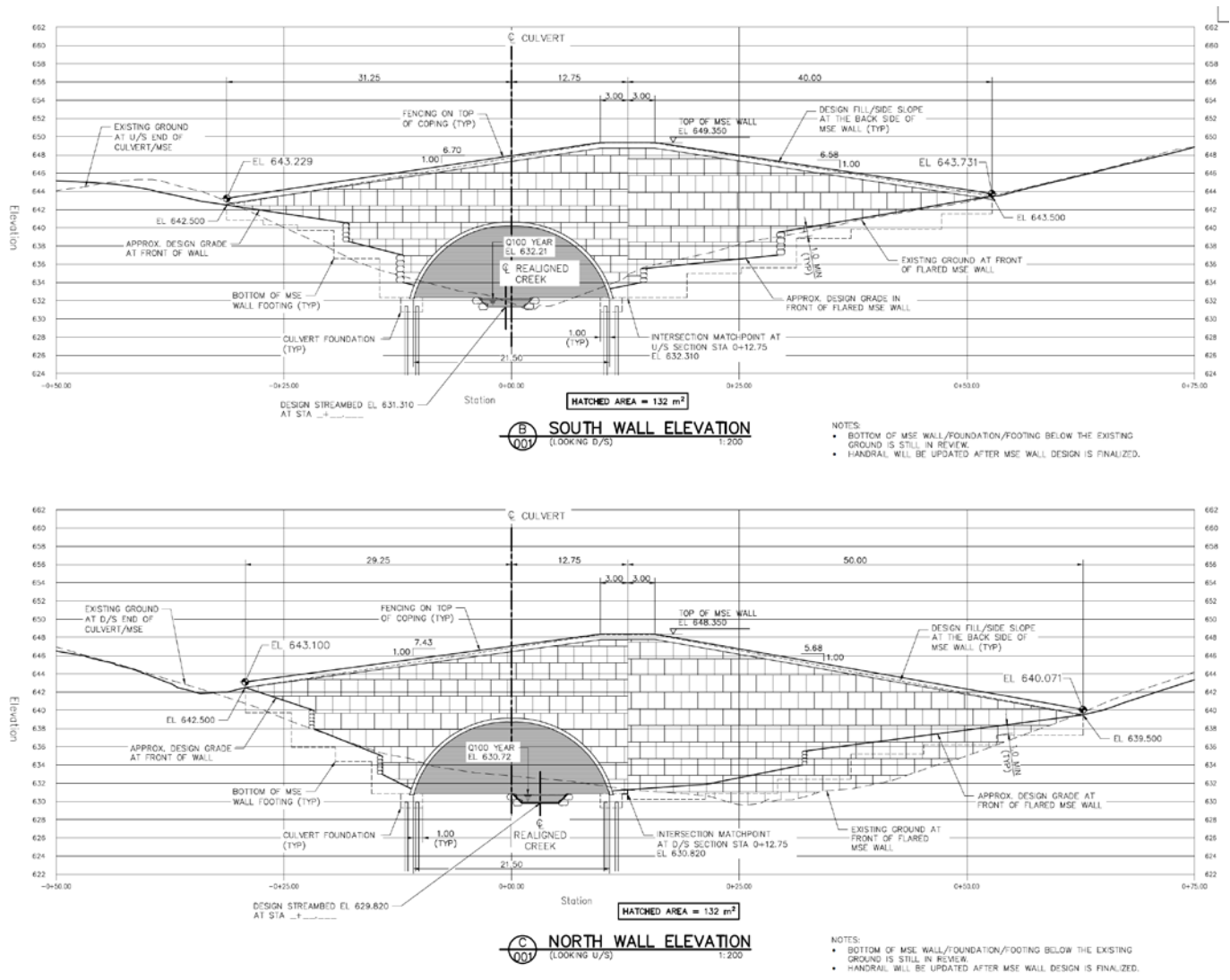

Figure 3. MSE Walls and Entrances to the Wildlife Crossing Structure (S001-004, 5 Dec 2016)

December 2016

4.1.2 Openness Index

The openness index is identified in City of Edmonton (2010) as $[\text{Height} \times \text{Width}] / \text{length}$ of a structure. This metric has been calculated to provide a context for comparison to the WPEDG. The WPEDG indicate an “optimal passage openness” of 1.5 is preferred for the Large Terrestrial EDG. The openness index for the December 2016 design of the concrete culvert crossing structure is 2.0 (rounded off from the exact value of 1.97), based on an area opening of 132 m² and a total length of 67 m, and is above optimal passage openness of 1.5 for the Large Terrestrial EDG as recommended in WPEDG (City of Edmonton 2010).

For larger wildlife (e.g., ungulates), shorter structures are expected to perform better at facilitating animal passage than longer structures. Although structures that exceed 37 m in length are not ideal for facilitating passage by large mammals (Cramer 2012), this does not mean that they cannot work effectively if otherwise properly designed. Remote camera surveys in Virginia, Pennsylvania, and Montana have documented successful use by white-tailed deer of crossing structures that were relatively long (58 to 87 m) with much smaller openings than the proposed structure at Clover Bar Creek (Brudin 2003; Foresman 2004; Donaldson 2005). Donaldson (2005) confirmed effective passage by deer of two culverts in Virginia that were 58 and 59 m in length with openings of 3 x 4 m and 6 x 5 m, respectively. In Montana, white-tailed deer “routinely use” a culvert 3.5 m wide x 3.75 m high x 65 m long (Foresman 2004). Brudin (2003) documented deer use of culverts 72 to 87 m in length with openings of 4 x 3 m and 5 x 3 m in Pennsylvania.

The length of the Clover Bar Creek crossing structure is not expected to deter species in the Medium Terrestrial EDG. The openness index of 2.0 is well above the 0.40 optimal passage openness indicated in Table 4-2 of the WPEDG for the Medium Terrestrial EDG. As well, coyotes in California have successfully used a wide variety of culvert sizes (some as small as 1 m in diameter), including structures between 58 and 145 m long (Ng et al. 2004; Phillips et al. 2012).

4.1.3 Line-of-Sight

Sight lines for animals approaching the structure are maximized since the structure largely follows the existing orientation of Clover Bar Ravine, and the elevation of the wildlife path within the crossing structure is located at near equal elevations (within 1.5 m) at the upstream end (632.75 m) versus the downstream end (631.25 m). Line-of-sight is estimated to be 20 to 50 m beyond the southeast entrance (upstream), and over 100 m beyond the northwest entrance (downstream) (Figure 4).

December 2016

4.2 DESIGN ELEMENTS FOR LARGE, MEDIUM, AND SMALL TERRESTRIAL ANIMALS, AND GROUND-DWELLING BIRDS

4.2.1 Wildlife Path

Wildlife pathways have been used successfully east of Golden, British Columbia to facilitate wildlife approaches to crossing structures on the Trans-Canada Highway. The Washington State Department of Transport include pathways in the “Passage Enhancement Toolbox” to improve the permeability of crossing structures for terrestrial wildlife (Washington Department of Transport 2016). Large, medium, and small animals will use pathways leading to and through wildlife crossing structures when they are properly designed.

The current design (December 2016) includes two animal pathways through the arch culvert to facilitate wildlife use (Figure 5). On the north side of the creek the wildlife path through the arch culvert varies in width between 9.0 and 12.0 m. There is a continuous brush pile against the edge of the culvert to provide hiding cover for small animals (Figure 6). Box culverts will be used to direct run-off from the roadway underneath the wildlife path on the north side of creek to avoid disruption of wildlife movements. Large mammals, as well as small and medium-sized wildlife can effectively use this path. On the south side of the creek the wildlife path varies in width between 1.5 and 4.0 m (Figure 6). Since this path is narrower and has less headroom, it is expected it will be used more frequently by small- and medium-sized wildlife, and less by larger species such as ungulates, which can cross using the path on the north side of the creek.

CLOVER BAR CREEK CROSSING AT AURUM ROAD: EVALUATION OF WILDLIFE PASSAGE

December 2016

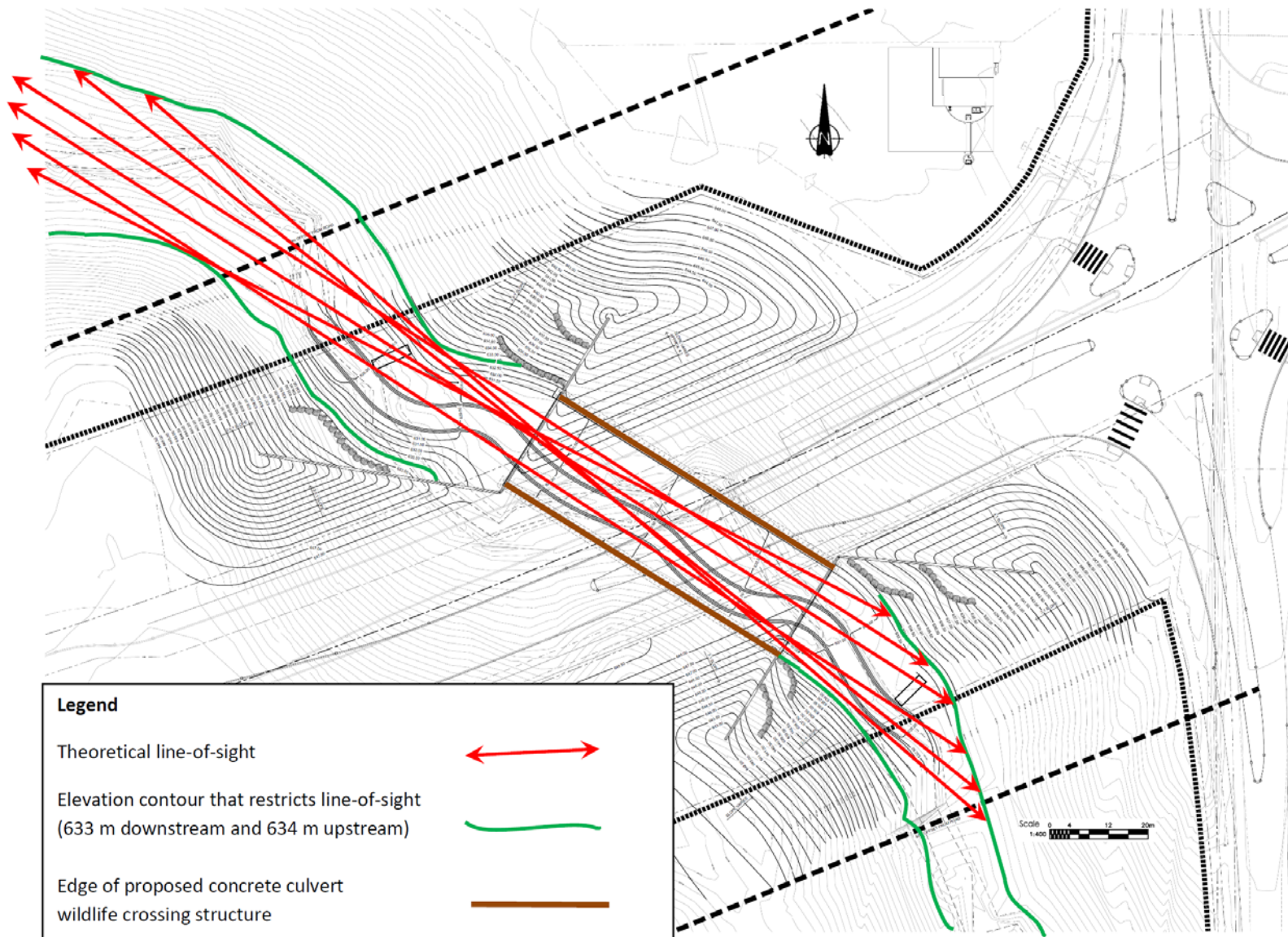

Figure 4 Estimated line-of-sight through the concrete arch wildlife crossing structure at Aurum Road

CLOVER BAR CREEK CROSSING AT AURUM ROAD: EVALUATION OF WILDLIFE PASSAGE

December 2016

Aurum Industrial Development Partnership
Creek Realignment
Concept Plan

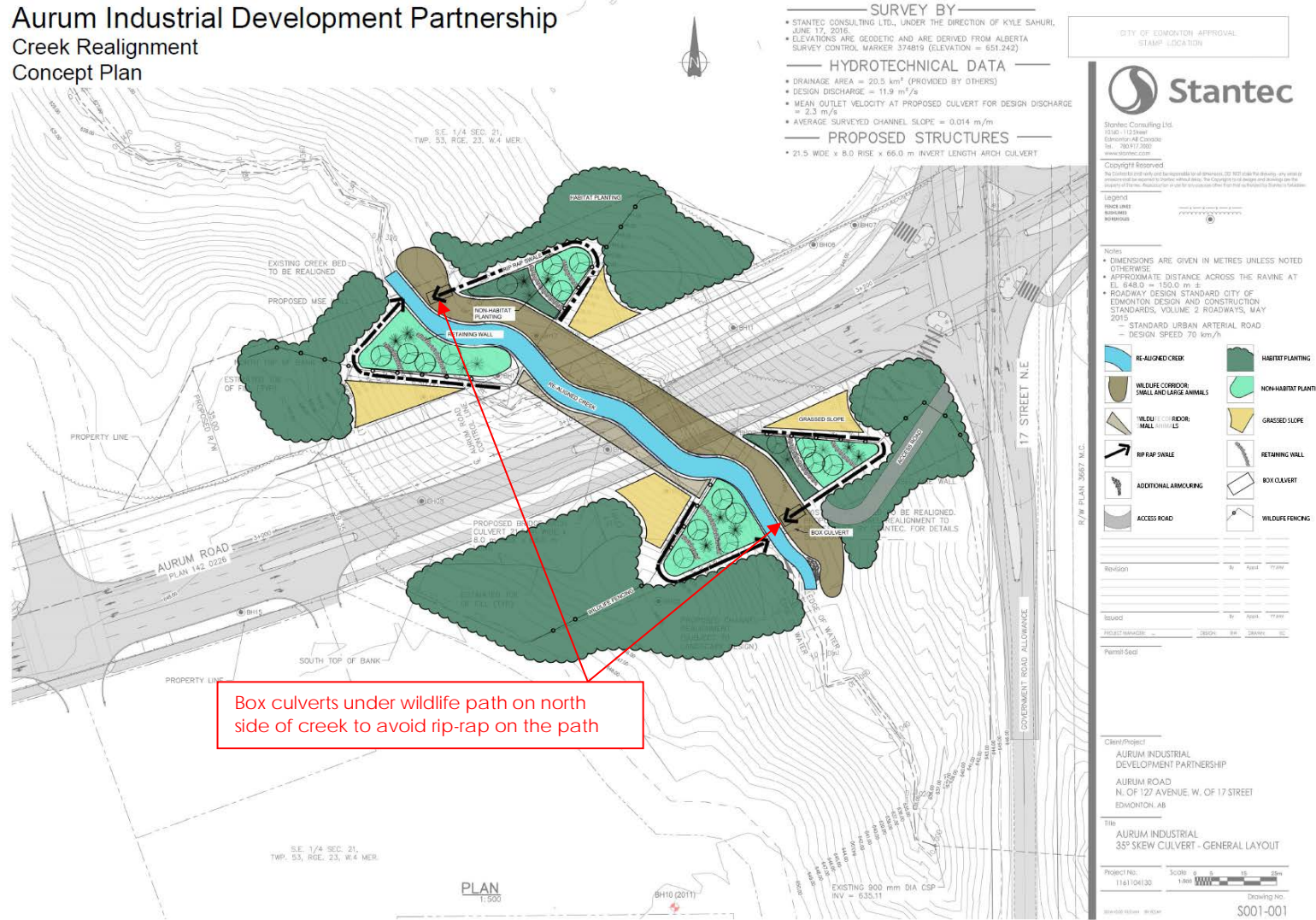

Figure 5 Landscaping Concept Plan (S001-001, 5 Dec 2016)

CLOVER BAR CREEK CROSSING AT AURUM ROAD: EVALUATION OF WILDLIFE PASSAGE

December 2016

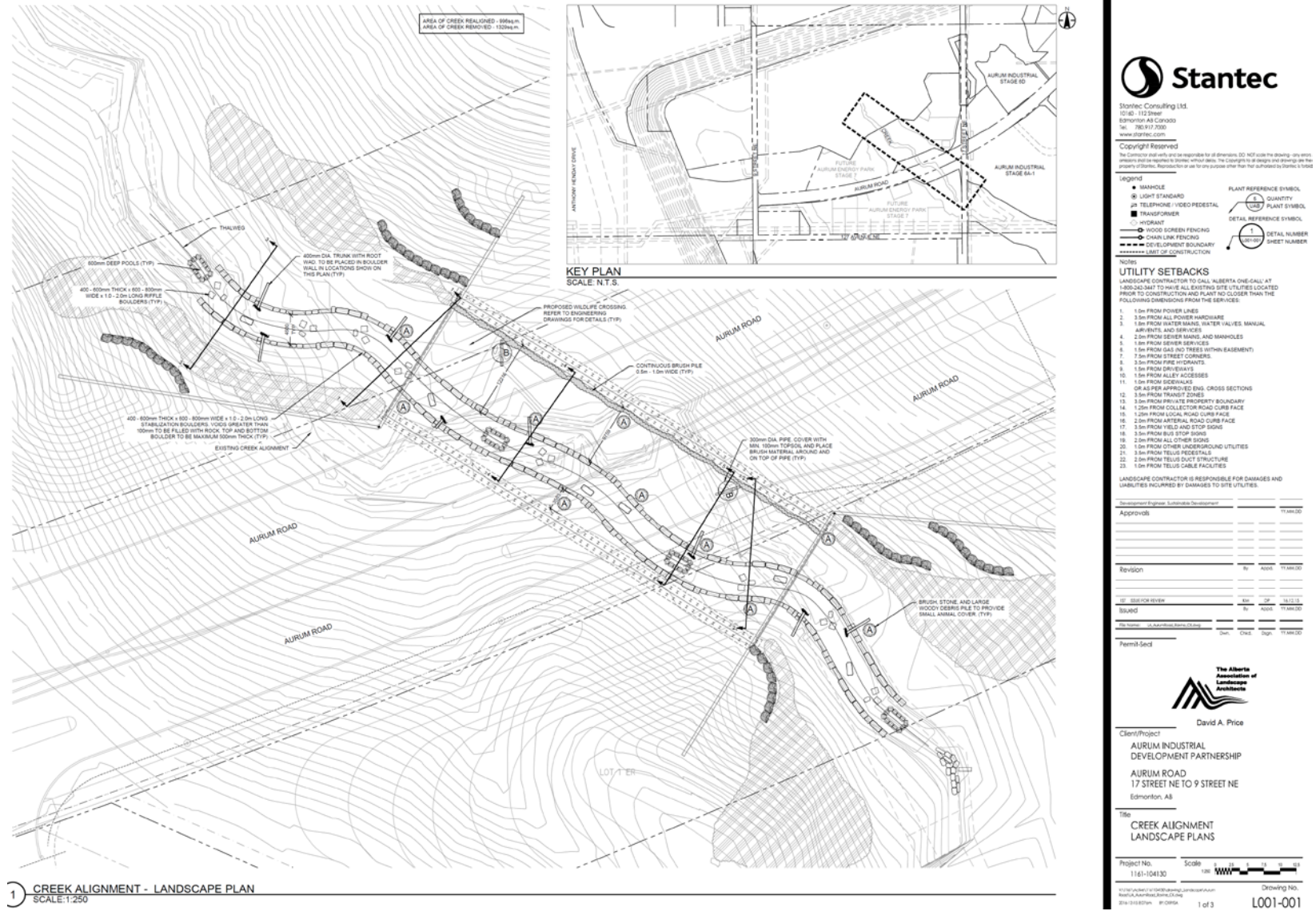

Figure 6 Creek Alignment Landscape Plan Showing Location of Brush Piles (L001-001, 15 Dec 2016)

December 2016

There are brush, stone, and large woody debris piles (a total of 10) to provide hiding cover for small and medium-sized animals on both the north and south wildlife paths. The wider north side wildlife path also has two installations of 300 mm diameter pipe covered with topsoil and brush material to provide additional wildlife hiding cover and improve the permeability of the structure for small- and medium-sized animals (Figure 6).

Stormwater modeling indicates that both wildlife paths will remain dry throughout the year, including during storms and 1:100-year spring snowmelt events.

4.2.2 Wildlife Exclusion Fencing

The location of wildlife fencing has been configured to direct wildlife towards the large concrete arch crossing structure. The ends of the fence will be located as close to the paved surface of Aurum Road as safety tolerances allow. The fence ends will not angle away from the road since this would tend to funnel animals traveling parallel to Aurum Road onto the paved surface and increase the potential for animal-vehicle collisions. A locked gate through the wildlife exclusion fencing will be required on the maintenance access road on the northeast corner of the wildlife crossing structure to minimize human disturbance. The preliminary fence alignments indicated in Figure 5 will be updated to reflect these prescriptions in the final design submission.

4.2.3 Landscaping

As much as possible, natural substrate and native vegetation will be used to landscape the approaches at both ends of the wildlife crossing structure. Landscaping will maintain a balance between sufficient cover for wildlife to feel safe entering, but not so much that there is not good visibility into and through the crossing structure (Kintsch and Cramer 2011).

As discussed earlier (Section 4.2.1), animal hiding cover will be installed within the culvert to provide protection from predators, and encourage use of the structure by small animals (Connolly-Newman 2013). This hiding cover includes stumps, rocks, debris piles and small sections of pipe (Clevenger & Huijser 2011).

4.2.4 Lighting

Wildlife-friendly lighting with reduced spill and glare should be incorporated in the final design of the road. Street lighting used on the road adjacent to the crossing should be directed onto the road surface and should avoid illuminating the entrances of the wildlife crossing structure and nearby natural features (City of Edmonton 2010).

4.2.5 Noise

Although excessive noise levels in wildlife crossing structures have the potential to reduce the crossing frequency of wildlife species, separating this effect from the other environmental characteristics has proven difficult. On the Trans-Canada highway in Banff National Park, noise

December 2016

was not a significant factor in the crossing performance for black bear, wolf, and cougar, but was negatively correlated (explaining between 16 and 28% of the variation in the crossing performance) for grizzly bear, elk, and deer (Clevenger and Waltho 2005). In Spain, the effect of noise on the use of 19 crossing structures by vertebrates was investigated along a major highway (Iglesias et al. 2012). However, the diversity of species using these structures, and the crossing frequencies of lagomorphs and foxes, were not negatively correlated with any of the noise indicators, and the only significant correlations found were positive. Noise levels on Aurum Road are not expected to be as high as the two studies mentioned above, since both traffic frequency and average vehicle speed will be much less than on a major highway. Furthermore, the fill over the concrete arch culvert should be effective at dampening any vehicle noise coming from the roadway above.

4.2.6 Conclusion

Based on the studies and analysis presented above, the current design for this wildlife crossing structure is considered adequate to allow effective passage of the Large Terrestrial, Medium Terrestrial, Small Terrestrial, and Ground Dwelling Birds EDGs.

4.3 DESIGN ELEMENTS FOR AMPHIBIANS AND AQUATIC SPECIES

Aquatic Species EDGs are particularly sensitive to poorly designed crossing structures (City of Edmonton 2010). Issues of increased water velocity and poorly embedded structures can create a barrier to upstream movement of aquatic species. The current stream channel design is sized, positioned, and configured to minimize flow velocities and avoid confining the channel. There will be an increase in coarse substrates (boulders, gravels, and sand) compared to the original stream substrate. Since coarse features are locally limiting in Clover Bar Creek, and these features will not impede passage for fish or amphibian species, they are considered habitat improvements, particularly for fish that require coarse surfaces to spawn on.

During 1:100-year flows, there will be a slight increase in the velocity in the channel (estimated at 10-20%) due to a shortening of the original channel. This slight increase in velocity is mitigated by increasing the "roughness" of the channel with riffles and deep pools. Changes in stream flow velocities during normal stream discharge will likely be less than the 10-20% increase estimated at peak discharge.

Amphibians utilize a mix of aquatic and terrestrial habitat components for juvenile and adult dispersal (Buskirk 2012). This crossing structure has both components, with the aquatic design features discussed above to provide amphibian passage along the creek, and hiding cover for small animals in the terrestrial wildlife paths on both sides of the creek (Section 4.2.1). The current design for this wildlife crossing structure is considered adequate to allow effective passage of Amphibian and Aquatic Species EDGs.

December 2016

4.4 DESIGN ELEMENTS FOR AERIAL MAMMALS, SCAVENGER BIRDS, BIRDS OF PREY, WATER BIRDS, AND OTHER BIRDS

For Aerial Mammals (i.e., bat) and bird EDGs, it is recommended that diversionary methods be incorporated to direct the flight of the birds and bats up and over the road as these species rarely use below grade crossing structures. The following above-grade mitigation measures are recommended to reduce the risk of collisions between vehicles and the Aerial Mammals, Scavenger Birds, Birds of Prey, Water Birds, and Other Birds EDGs as they fly over Aurum Road:

- Use natural vegetation and tree plantings to direct the flight paths of birds and bats higher over the road, above the traffic (Tremblay 2006). This measure will also minimize the reduction in habitat created by the road right-of-way, and maintain the aesthetics of the area. To accomplish this measure, clearing of trees and vegetation should be minimized along Aurum Road and tree plantings should be designed to grow taller than the highest vehicles using the road.
- Consideration should be given to installing taller street lights. Since large numbers of insects typically gather near light sources, installation of taller lights should direct bats to fly higher and thereby avoid vehicle collisions.

5.0 CLOSURE

This evaluation of design for wildlife passage on the Aurum Road crossing of Clover Bar Creek was prepared by Stantec Consulting Ltd for the Aurum Industrial Development Partnership. The material in it reflects Stantec's best judgment, considering the information available to it at the time of preparation. Any use which a third party makes of this report, or any reliance on or decisions made based on it, are the responsibilities of such third parties. Stantec Consulting Ltd. accepts no responsibility for damages, if any, suffered by any third party as a result of decisions made or actions based on this report.

Stantec has endeavored to incorporate the principles of the WPEDG into the Aurum Road wildlife passage design and the constraints associated with the physical site characteristics and available materials. We trust that this information is sufficient to support the submission of the detailed design.

Respectfully submitted,

STANTEC CONSULTING LTD.



William L. Harper, M.Sc., R.P.Bio.
Senior Wildlife Biologist

December 2016

6.0 REFERENCES

- Brudin, C.O. 2003. Wildlife use of existing culverts and bridges in North Central Pennsylvania. In, Proceedings of the 2003 International Conference on Ecology and Transportation (C.L. Irwin, P. Garrett, and K.P. McDermott, eds.) Center for Transportation and the Environment, North Carolina State University, Raleigh, NC. pp. 344-352. Accessed December 15, 2016, from: <http://escholarship.org/uc/item/67f406zv>
- Buskirk, J. 2012. Permeability of the landscape matrix between amphibian breeding sites. *Ecology and Evolution*, 2(12): 3160–3167. Accessed December 15, 2016, from: <https://www.ncbi.nlm.nih.gov/pmc/articles/PMC3539008/>
- City of Edmonton. 2010. Wildlife passage engineering design guidelines. Report prepared by Stantec Consulting Ltd. for the Office of Natural Areas, City of Edmonton, AB. 249 pp. Accessed October 14, 2015, from: http://www.edmonton.ca/city_government/documents/PDF/WPEDG_FINAL_Aug_2010.pdf
- Clevenger, A.P. and N. Waltho. 2005. Performance indices to identify attributes of highway crossing structures facilitating movement of large mammals. *Biological Conservation* 121: 453–464. Accessed on October 14, 2015, from: <http://www.sciencedirect.com/science/article/pii/S0006320704002319>
- Clevenger, A.P. and M.P. Huijser. 2011. Wildlife crossing structure handbook: Design and evaluation in North America. Report FHWA-CFL/TD-11-003 by the Western Transportation Institute, Bozeman, MT for the U.S. Federal Highway Administration, Central Federal Lands Highway Division, Lakewood, CO. 224 pp. Accessed on October 14, 2015, from: http://roadeology.ucdavis.edu/files/content/projects/DOT-FHWA_Wildlife_Crossing_Structures_Handbook.pdf
- Connolly-Newman, H.R., M.P. Huijser, L. Broberg, C.R. Nelson, and W. Camel-Means. 2013. Effect of cover on small mammal movements through wildlife underpasses along us Highway 93 North, Montana, USA. Proceedings of the 2013 International Conference on Ecology and Transportation (ICOET 2013). Accessed on October 14, 2015, from: <http://scholarworks.umt.edu/cgi/viewcontent.cgi?article=1369&context=etd>
- Cramer, P. 2012. Determining wildlife use of wildlife crossing structures under different scenarios. Report No. UT-12.07 prepared by Department of Wildland Resources and Utah Transportation Center, Utah State University, Logan, UT for the Utah Department of Transportation, Salt Lake City, Utah. 181 pp. Accessed on October 14, 2015, from: <http://www.udot.utah.gov/main//uconowner.gfn=10315521671291686>

CLOVER BAR CREEK CROSSING AT AURUM ROAD: EVALUATION OF WILDLIFE PASSAGE

December 2016

Donaldson, B.M. 2005. The use of highway underpasses by large mammals in Virginia and factors influencing their effectiveness. Final report (VTRC 06-R2) to the Virginia Transportation Research Council, Virginia Department of Transportation and the University of Virginia, Charlottesville, Virginia. 38 pp. Accessed on December 14, from: http://www.viriniadot.org/vtrc/main/online_reports/pdf/06-r2.pdf

Foresman, K.R. 2004. The effects of highways on fragmentation of small mammal populations and modifications of crossing structures to mitigate such impacts. Final Report (FHWA/MT-04-005/8161) prepared for the Montana Department of Transportation, Federal Highway Administration. Helena, MT. 45 pp. Accessed December 15, 2016, from: <http://ia802608.us.archive.org/23/items/FE10D49E-23A2-47AA-BF41-B3ACC522265C/FE10D49E-23A2-47AA-BF41-B3ACC522265C.pdf>

Found, R. and M.S. Boyce. 2011. Predicting deer-vehicle collisions in an urban area. *Journal of Environmental Management*. 92:2486-2493.

Iglesias, C., C. Mata and J.E. Malo. 2012. The influence of traffic noise on vertebrate road crossing. *AMBIO* 41: 193-201. Accessed on October 2, 2015, from: <http://www.ncbi.nlm.nih.gov/pmc/articles/PMC3357842/>

Kintsch, J. and P.C. Cramer. 2011. Permeability of existing structures for terrestrial wildlife: A passage assessment system. Research Report No. WA-RD 777.1. Washington State Department of Transportation, Olympia, WA. 188 pp. Accessed on October 14, 2015, from: <http://www.wsdot.wa.gov/research/reports/fullreports/777.1.pdf>

Ng, S.J., J.W. Dole, R.M. Sauvajot, S.P.D. Rieley and T.J. Valone. 2004. Use of highway undercrossings by wildlife in southern California. *Biological Conservation* 115: 499-507. Available: <http://www.elkhornsloughctp.org/uploads/files/1182960903highway%20undercrossings.pdf> Accessed June 13, 2014

Phillips, J., R. Phillips, N. Srinivasan, D. Aso, W. Lao and P. Cornely. 2012. Safe passage for Coyote Valley: a wildlife linkage for the Highway 101 corridor. Kirsch Center for Environmental Studies, De Anza College, Cupertino, CA. 35 pp. Accessed on October 14, 2015, from: <https://www.deanza.edu/es/wildlifecorrproj/Safe%20Passagelowres.pdf>

Ruediger, B. and M. DiGiorgio. 2007. Safe Passage: A User's Guide to Developing Effective Highway crossings for Carnivores and other Wildlife. USDA Forest Service and Wilberforce. 19 pp. Accessed on October 14, 2015, from: <http://www.wildlifeconsultingresources.com/pdf/Carnivore%20Safe%20PassageFinalSMA LL.pdf>

Spencer Environmental Management Services Ltd. 2014. Aurum Road Clover Bar ravine crossing: Wildlife movement and wetland analysis. Draft report prepared for City of Edmonton

CLOVER BAR CREEK CROSSING AT AURUM ROAD: EVALUATION OF WILDLIFE PASSAGE

December 2016

Office of Ecology, under contract to Al-Terra Engineering Ltd (Project Number EP591),
Edmonton, AB. 64 pp.

Tremblay, M. 2006. Assessing functional landscape connectivity for songbirds in an urban environment. In, C. L. Irwin, P. Garrett, and K. P. McDermott (Ed.), Proceedings of the 2005 International Conference on Ecology and Transportation (pp. 563-564). Centre for Transportation and the Environment, North Carolina State University, Raleigh, North Carolina.

Washington Department of Transport. 2016. Passage Enhancement Toolbox (website). Accessed December 14, 2016 from: <http://www.wsdot.wa.gov/NR/rdonlyres/AECC63E5-76FA-411B-9B28-15E1FB9388EF/0/PassageEnhanceToolbox.pdf>

APPENDIX H
GEOMORPHOLOGY - GEOTECHNICAL
TECHNICAL MEMO

To:	Kurtis Fouquette	From:	Ralph Walters
	Stantec 10160 112 Street Edmonton, AB T5K 2L6		Stantec 10160 112 Street Edmonton, AB T5K 2L6
File:	1161104130	Date:	March 6, 2017

Reference: Aurum Road Over Clover Bar Creek and Ravine – Geomorphology – Geotechnical Technical Memo

Background

The existing and proposed development in this area requires that this section of Aurum Road is to provide access to this area and connect to the Anthony Henday Drive to the west and the developed area to the east. A 21.5 m span X 8 m rise precast concrete arch structure, 67.2 m in length, is proposed to meet the requirements for wildlife passageway in this ravine. With the existing meandering pattern of the creek in this reach a 166 m long re-alignment of the creek is required. The width of the meandering pattern of the creek is to be contained within 50% of the arch width so that the required wildlife passageway width can be maintained. (See Drawing S001-00 1 included in Appendix C of Stantec's Preliminary Engineering Design Report submitted to the City of Edmonton on January 13, 2017)

The design of the 166 m creek re-alignment is such that any future works upstream of and at 17 Street as well as any works downstream of the re-alignment section would not be affected by the proposed design of this reach. (See **Attachments 1 and 2**) The hydraulic parameters of the re-aligned creek are designed so they meet the existing channel hydraulic parameters where the channels reconnect. The design intent is that sediment transport in this reach will not be significantly altered by this re-alignment.

Geomorphology-Geotechnical - Summary

The North Saskatchewan River and its tributaries were cut down during the drainage of the Edmonton Glacial Lake some 12,000 years ago. There is little evidence of further down cutting over the past 8,000 years with the river and its tributaries meandering laterally and thus widening its valley width rather than degrading. As this lateral erosion continues the river and its tributary valleys continue to be affected by under cutting and slumping especially at the outside of the meander bends.

The bedrock underlies surficial glaciolacustrine and glacial till deposits. This Horseshoe Canyon Formation is generally comprised of interbedded mudstones (bentonite shales), sandstone and coal seams with occasional bentonite seams. As was identified by the boreholes drilled and logged for this area slickensided seams were present at several locations. This presented stability issues for the ravine walls and the design had to accommodate these concerns. A review of the aerial photographs of the ravine did not indicate any active slumping of the slopes. It is considered that ravines slopes were formed during the down cutting phase of the river valley system and that these slopes are presently inactive-mature movements. These slopes could again be reactivated by

Design with community in mind

Reference: Aurum Road Over Clover Bar Creek and Ravine – Geomorphology – Geotechnical Technical Memo

lateral erosion or grading activities. Constant monitoring by geotechnical personnel, during the construction phase, is proposed.

Several boreholes were drilled to elevations below the creek bed and disturbed material and organic material was encountered approximately 2 m below the bed. The boreholes also revealed a shear plane a few metres below the existing streambed elevation. The ground water elevations varied considerably and any construction activities will need to accommodate the ground water encountered with a drainage system, i.e., trench drains, etc. It appears that the creek cut down to below the present creek level in the geological past, i.e. sometime after the glaciers retreated. The channel bed then aggraded likely through the process of valley wall slumping. The channel bed in this reach appears to have reached equilibrium and little if any down cutting is expected to occur.

As shown on Clover Bar Creek Profile (See **Attachment 2**) the creek is at approximately a 1.62% slope from 17 Street to 940 m downstream and then flattens to a 0.35% slope to 137 Avenue and then again steepens to 2.6% as it drops to meet the North Saskatchewan River. Considerable ditching of Clover Bar Creek has occurred from the reach some 940 m downstream of 17 Street to 137 Avenue. The 166 m re-alignment section within the 940 m reach of Clover Bar Creek has been designed so that any future works downstream and upstream of the proposed re-alignment would not affect fisheries etc.

Fluvial process of streams – streams are conduits of water as well as sediment. Water as it flows over the channel bottom mobilizes sediment and transports it downstream. The rate of sediment transport is dependent upon the availability of sediment and the streams discharge. For this site the rate of sediment is somewhat restricted as the 17 Street embankment and the under sized 900 mm CSP culvert act as a dam. This results with much of the sediment being deposited on the upstream embankment and the availability of sediment is reduced. With this situation the flow, leaving the re-alignment channel and again joining the existing channel, is expected to have a slight deficiency of available sediment. This is comparable to the situation before the re-alignment is constructed.

Clover Bar Creek Hydrology and Hydraulics - Clover Bar creek has a drainage area of 21.0 km² for this site and was determined by UMA/AECOM (See UMA report "City of Edmonton Clover Bar Creek Storm PAC Development", Dated August 2008. The upper drainage area, which is approximately 13.5 km², is in Strathcona County while the lower 7.5 km² is located in the eastern part of the City of Edmonton. Clover Bar creek ultimately discharge into the North Saskatchewan River. The maximum allowable discharge rate for Clover Bar creek basins is 0.004 m³/s/ha. The Clover Bar drainage basin has had major changes to it by development, pipelines, etc. from its original situation say some 100 years ago. These changes have affected the hydrology and hydraulic characteristics of this creek. Upstream of Yellowhead Trail (hwy 16) Clover bar creek mainly originates from storm water ponds which release discharge at a slow rate (i.e. 0.004 m³/s/ha). Based on UMA report the existing capacity, flowing at H/D = 1.5, of culverts 352, 356, 362, 436 and 402 are given below in **Table 1**. **Attachment 1** shows the location of these culverts along Clover Bar creek.

Reference: Aurum Road Over Clover Bar Creek and Ravine – Geomorphology – Geotechnical Technical Memo

Table 1: Hydraulic Capacity of Culverts along Clover Bar Creek (Based on UMA report)

Culvert Number	Culvert Location	Culvert Capacity (m³/s)	Comments
352	Located under Railway Track	1.8	
356	Located under access road	3.2	
362	Located under 17 Street	1.5	Surveyed size of culvert 900 mm. This culvert is approximately 175 upstream of Aurum road proposed crossing
436	Located under 17 Street. This culvert is located downstream of proposed crossing	0.6	See attachment 3 to see site photo
402	Located under 137 Avenue	17	See attachment 3 to see site photo

These culverts presently provide control for flows through Clover Bar Creek. Please see site photos included in **Attachment 3**. Section 3.0 in Preliminary Engineering Design Report submitted to City on January 13, 2017 explains the basis of recommended potential design discharge of 11.9 m³/s. The potential maximum discharge for the basin is estimated without flow controls, such as undersized culverts, ditching, floodplain storage, stormwater ponds, etc. File review/historical discharges, channel hydraulics, channel capacity method and basin runoff potential method with site assessment were utilized to estimate design discharge.

Based on modelling results presented in **Table 2** of the Preliminary Engineering Design Report submitted to the City of Edmonton on January 13, 2017, for design flood, the average channel velocity entering the re-aligned channel at the upstream end is 2.55 m/s, while that of in the natural channel is 2.15 m/s. The proposed re-aligned channel bed width is 4.0 m and is designed with pool and riffles to mitigate flows for fish and provide fish habitat enhancements. The rock riprap and fish habitat enhancement measures (see **Attachment 4**) installed in the realigned channel will increase average roughness of the new channel and by the time flow leaves the realigned channel, the average velocity in the channel will be similar to the downstream natural channel velocity. The average channel velocity in the realigned channel at the downstream end is calculated as 2.08 m/s. In essence, the realigned channel is having minimum change in downstream velocity for design flood. We anticipate low erosion concerns in the natural channel downstream of the realigned channel due to the change in velocity of the realignment of the channel. The re-aligned channel is designed to maintain equilibrium state of the downstream channel similar to prior channel re-alignment.

Aurum road crossing over clover bar creek proposed 21.5 m span x 8 m rise x 67.2 m long open bottom arch structure would be constructed by replacing weak material with engineered granular material, as required, to attain structural stability as per geotech requirement. Erosion control measures along with surface drainage would be designed to arrest sediment transport to creek in project area. These measures would have minimum impact on surface, seepage and ground water flows. In essence there would be little if any impact on surface and ground water hydrology in



March 6, 2017
Kurtis Fouquette
Page 4 of 4

**Reference: Aurum Road Over Clover Bar Creek and Ravine – Geomorphology – Geotechnical
Technical Memo**

project area. Please see Aurum Energy Park Stage 7 report submitted to City on January 13, 2017 to see drainage and sediment erosion control measures installed during several phases of project.

STANTEC CONSULTING LTD.

A handwritten signature in blue ink, appearing to read "Ralph Walters".

Ralph Walters, MSc.,P.Eng.
Sr. Bridge Planning and River Engineer
Phone: (780) 917-7086
Fax: (780) 917-7086
ralph.walters@stantec.com

A handwritten signature in black ink, appearing to read "Arshed Mahmood".

Arshed Mahmood, MSc.,P.Eng.
Bridge Planning and River Engineer
Phone: (780) 917-6958
Fax: (780) 917-7086
arshed.mahmood@stantec.com

Attachment: Attachment 1 - Storm Servicing Concept for the Ultimate Development Condition
Attachment 2 – Clover Bar Creek Profile
Attachment 3 - UMA/AECOM and Stantec Site Photographs
Attachment 4 – Fish Habitat Enhancement Measures

**ATTACHMENT 1
STORM SERVICING CONCEPT
FOR THE ULTIMATE DEVELOPMENT CONDITION**

ISS/REV: E
 UMA FILE NAME: 0083-267-00_01-CWF401_RE.dwg Saved By: chaob
 PLOT: 08/08/26 3:52:10 PM
 B SIZE 11" x 17" (279.4mm x 431.8mm)

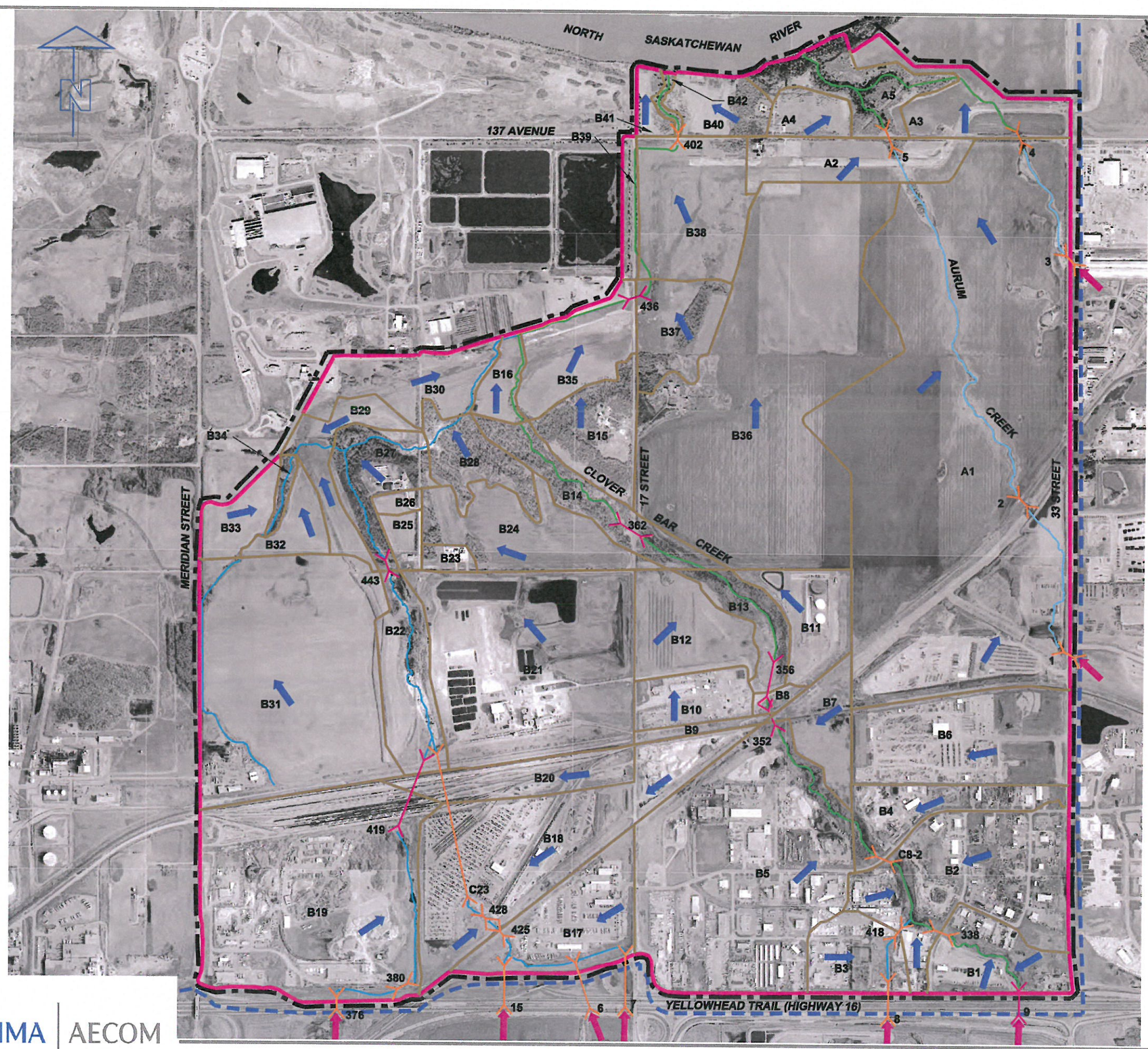

LEGEND

- CITY OF EDMONTON BOUNDARY
- - - STUDY AREA BOUNDARY
- BASIN BOUNDARY
- SUB-CATCHMENT BOUNDARY
- CLOVER BAR CREEK
- AURUM CREEK
- CREEK CHANNEL IMPROVEMENTS
- 376 EXISTING CULVERT c/w NUMBER
- 9 UPGRADED CULVERT c/w NUMBER
- FLOWS FROM STRATHCONA COUNTY
- OVERLAND FLOW DIRECTION
- B1 SUB-CATCHMENT AREA NAME

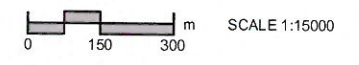

City of Edmonton
 Clover Bar Creek
 Storm PAC Development
**Storm Servicing Concept for the
 Ultimate Development Condition**
 Figure 4.1

**ATTACHMENT 2
CLOVER BAR CREEK PROFILE**

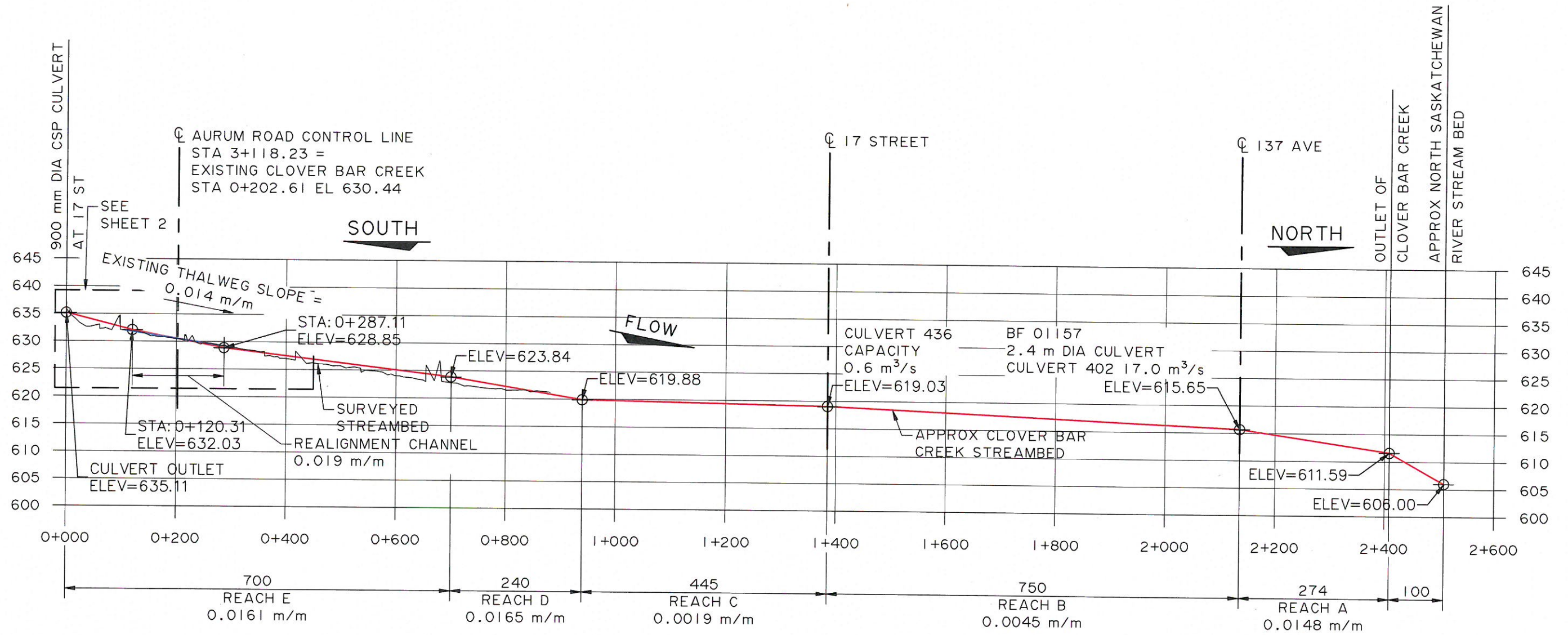

CLOVER BAR CREEK PROFILE

HOR 1:7500
VERT 1:750

SURVEY BY STANTEC CONSULTANT LTD. EDMONTON, ALBERTA UNDER
THE DIRECTION OF KYLE SAHURI, COMPLETED JUNE 17, 2016

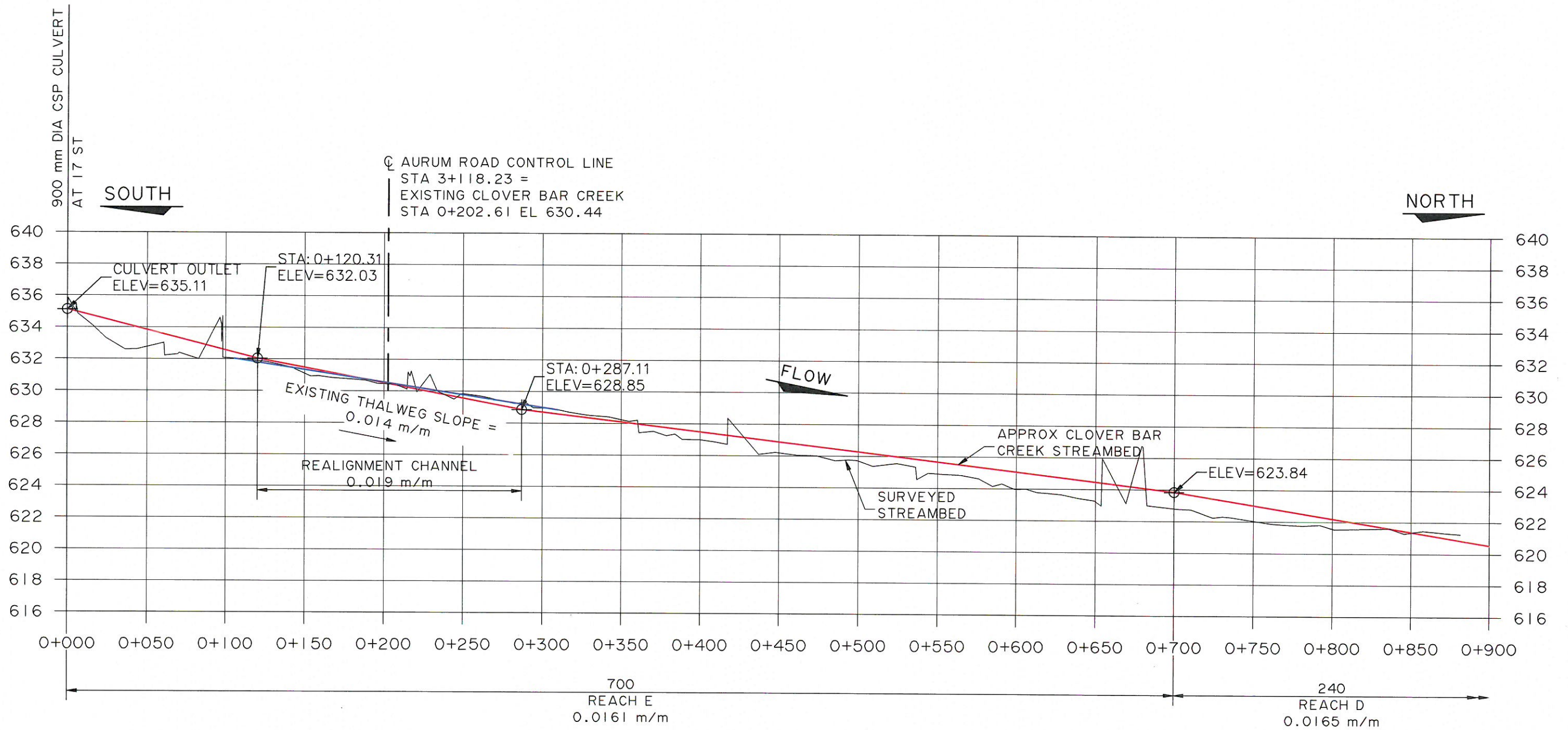

CLOVER BAR CREEK PROFILE

HOR 1:2500
 VERT 1:250

SURVEY BY STANTEC CONSULTANT LTD. EDMONTON, ALBERTA UNDER
 THE DIRECTION OF KYLE SAHURI, COMPLETED JUNE 17, 2016

SHEET 2

**ATTACHMENT 3
UMA/AECOM AND STANTEC SITE PHOTOGRAPHS**



Culvert C8-2 Inlet.

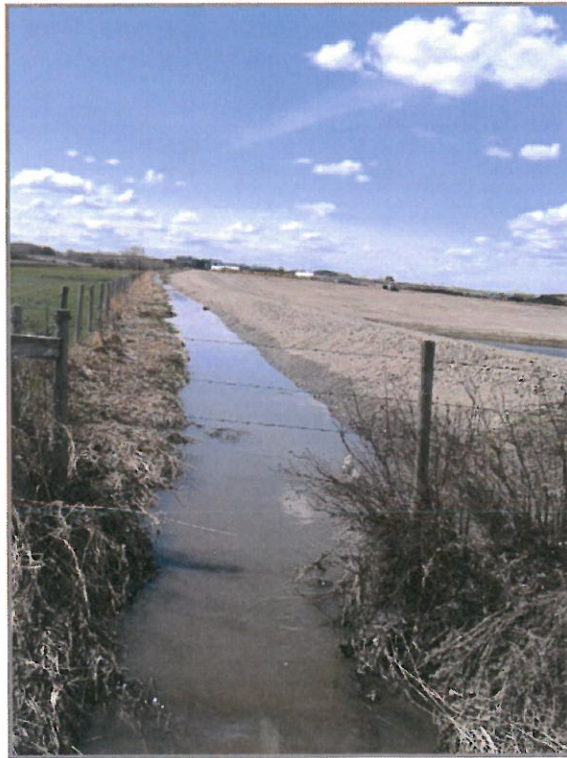

Looking West (Upstream) of Culvert 436.



Culvert 436 Inlet.



Existing Ditch from Culvert 436 to Culvert 402. Looking Downstream (North) of Culvert 436.



Existing Ditch from Culvert 436 to Culvert 402. Looking Upstream (South) of Culvert 402.



Looking North (Downstream) Through Culvert 402.



Clover Bar Creek Downstream of Culvert 402.



Aurum Creek Downstream of Culvert 5.



Photo 1: Looking downstream (north) from downstream of proposed crossing. Note debris.



Photo 2: Looking upstream (south) from downstream of crossing. Note debris.



Photo 3: Looking downstream (north) from approximate crossing centerline.



Photo 4: Looking upstream (south) from approximate crossing centerline.



Photo 5: Looking upstream (south) from upstream of crossing.



Photo 6: Looking downstream (north) from east of crossing.



Photo 7: Looking upstream (south) from upstream of crossing. Note beaver dam and east bank erosion.



Photo 8: Looking at streambed material.



Photo 9: Looking downstream at existing watercourse in vicinity of crossing.



Photo 10: Looking upstream (south) at crossing centerline. Note beaver dam



Photo 11: Looking upstream (south) at upstream of proposed crossing. Note lateral bank erosion.



Photo 12: Looking downstream (north).

**ATTACHMENT 4
FISH HABITAT ENHANCEMENT MEASURES**



Stantec Consulting Ltd.
1016 - 1123 Ave.
Edmonton, AB T6C 2T1
www.stantec.com

Copyright Reserved

This contract and any site specific regulations, conditions, or notes on the drawing, drawings or project of record, shall constitute the entire agreement between the client and the contractor. Reproduction or use for any purpose other than that authorized by Stantec is prohibited.

Legend

- MANHOLE
- ⊕ LIGHT STANDARD
- ☑ TELEPHONE / VIDEO CABINET
- WATER METER
- ▭ HYDRANT

NOTES

UTILITY SETBACKS

- 1. LOCATIONS TO BE MAINTAINED AS IS
- 2. LOCATIONS TO BE MAINTAINED AS IS, EXCEPT FOR THE UTILITIES LOCATED PRIOR TO CONSTRUCTION AND PLANT TO CLARGER THAN THE FOLLOWING DIMENSIONS FROM THE SERVICES:
 1. 5.0m FROM ALL POWER HARDWARE
 - 1.6m FROM ALL SERVICE WATER VALVES, MANHOLE
 - 2.0m FROM SEWER MAINS AND MANHOLES
 - 2.0m FROM GAS AND TRENCHING (WITH EASEMENT)
 - 1.5m FROM STREET LIGHTS
 - 1.5m FROM DRIVEWAYS
 - 1.5m FROM SIDEWALKS
 - 1.0m FROM SIDEWALKS
- 3. GRASSY FRONT YARD CROSSLANE CROSS SECTIONS
- 4. 3.0m FROM PRIVATE PROPERTY BOUNDARY
- 5. 1.20m FROM LOCAL ROAD CURB FACE
- 6. 1.20m FROM LOCAL ROAD CURB FACE
- 7. 1.50m FROM LOCAL ROAD CURB FACE
- 8. 3.0m FROM BUS STOP SIGN
- 9. 1.50m FROM OTHER UNDERGROUND UTILITIES
- 10. 1.50m FROM TRENCH EXPOSURE
- 11. 1.50m FROM TRENCH EXPOSURE
- 12. 1.50m FROM TRENCH EXPOSURE
- 13. 1.50m FROM TRENCH EXPOSURE
- 14. 1.50m FROM TRENCH EXPOSURE
- 15. 1.50m FROM TRENCH EXPOSURE
- 16. 1.50m FROM TRENCH EXPOSURE
- 17. 1.50m FROM TRENCH EXPOSURE
- 18. 1.50m FROM TRENCH EXPOSURE
- 19. 1.50m FROM TRENCH EXPOSURE
- 20. 1.50m FROM TRENCH EXPOSURE
- 21. 1.50m FROM TRENCH EXPOSURE
- 22. 1.50m FROM TRENCH EXPOSURE
- 23. 1.50m FROM TRENCH EXPOSURE

LANDSCAPE CONTRACTOR IS RESPONSIBLE FOR DAMAGES AND LIABILITIES INCURRED BY DAMAGES TO UTILITIES.

DESCRIPTION	BY	DATE	APPVED
APPROVED			
REVISION			
1. TO CLARIFY	12/11/20		
2. TO CLARIFY	12/11/20		
3. TO CLARIFY	12/11/20		
4. TO CLARIFY	12/11/20		
5. TO CLARIFY	12/11/20		
6. TO CLARIFY	12/11/20		
7. TO CLARIFY	12/11/20		
8. TO CLARIFY	12/11/20		
9. TO CLARIFY	12/11/20		
10. TO CLARIFY	12/11/20		
11. TO CLARIFY	12/11/20		
12. TO CLARIFY	12/11/20		
13. TO CLARIFY	12/11/20		
14. TO CLARIFY	12/11/20		
15. TO CLARIFY	12/11/20		
16. TO CLARIFY	12/11/20		
17. TO CLARIFY	12/11/20		
18. TO CLARIFY	12/11/20		
19. TO CLARIFY	12/11/20		
20. TO CLARIFY	12/11/20		
21. TO CLARIFY	12/11/20		
22. TO CLARIFY	12/11/20		
23. TO CLARIFY	12/11/20		
24. TO CLARIFY	12/11/20		
25. TO CLARIFY	12/11/20		



Client/Project
David A. Price
AURUM INDUSTRIAL
DEVELOPMENT PARTNERSHIP

17 STREET NE TO 9 STREET NE
Edmonton, AB

Title
CREEK AND Ravine RESTORATION
Creek ENLARGMENT GRADING AND
LAYOUT
Project No. 1161-04130
Scale: 1:250
Drawing No. L200-002

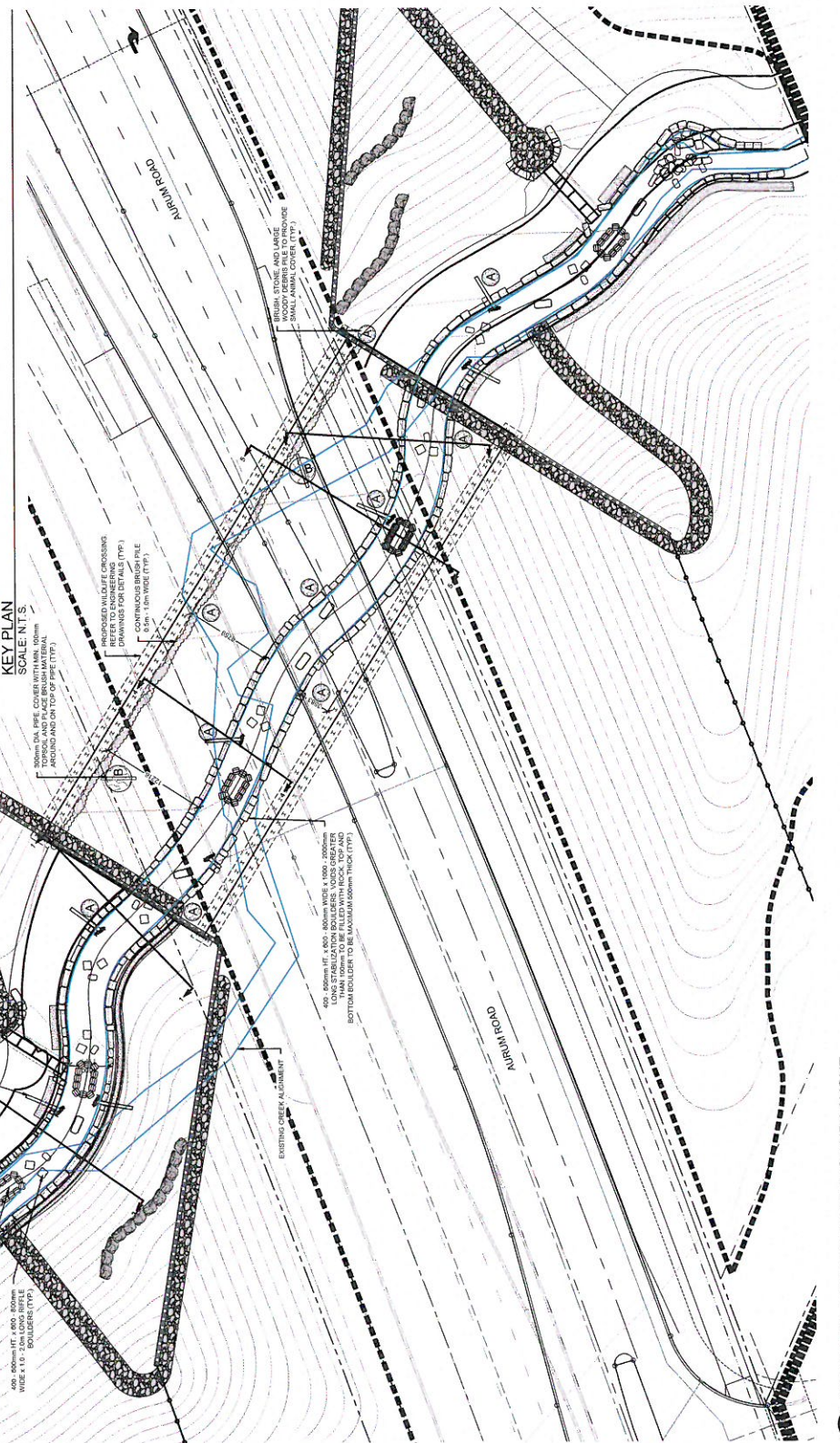
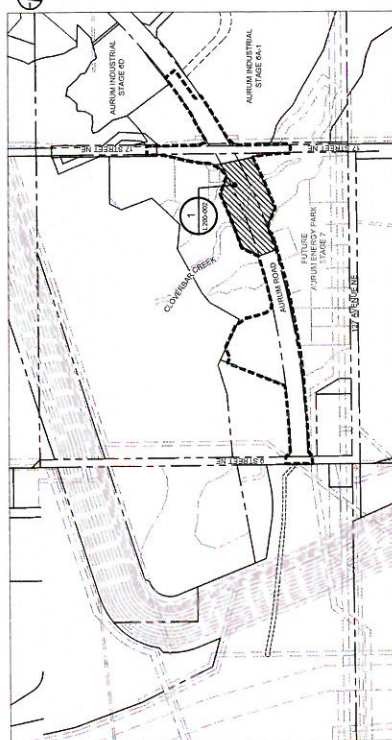

1 CREEK ENLARGMENT GRADING AND LAYOUT SCALE: 1:250