

HANGAR 11 - BLATCHFORD

- HISTORIC BUILDING RECORD
- HISTORIC BUILDING CONDITION ASSESSMENT
- CONSERVATION PLAN

December 20, 2019





A 1945 south-facing view of the U.S. Army Air Base (left) and Hangars T1-T4 (right), on the east side of the Edmonton Municipal Airport. The third hangar in the line, formerly Hangar T3, is the remaining Hangar 11. (City of Edmonton)

COVER PAGE: Northwest Industries Hangar at Edmonton Municipal Airport, 1956.
(Flight Magazine)

PREPARED FOR:

City of Edmonton
Infrastructure, Planning and Design
12th Floor, 10111-104 Avenue NW
Edmonton AB, T5J 1J4

PREPARED BY:

ERA Architects Inc.
#600-625 Church St
Toronto ON, M4Y 2G1
416-963-4497

GEC Architecture
#310, 14055 West Block Dr. NW
Edmonton, AB, T5N 1L8
780-421-8060

TABLE OF CONTENTS

EXECUTIVE SUMMARY

vii

PART I: HISTORIC BUILDING RECORD: HISTORY, CONTEXT & EVALUATION

1	INTRODUCTION	1
1.1	Scope of the Report	
1.2	Site Description and Context	
1.3	Current Heritage Recognition	
1.4	Project Description and Background	
1.4.1	Previous Studies and Reports	
2	SITE HISTORY	7
2.1	Edmonton's Municipal Aerodrome: 1919-1939	
2.2	Blatchford Field during World War II: 1939-1945	
2.4.1	The British Commonwealth Air Training Plan: 1940-1944	
2.4.2	Aircraft Repair Ltd.: 1936-1945	
2.4.3	The U.S. Army Air Force and the Northwest Staging Route: 1942-1944	
2.4.4	Hangar 11 Design and Construction	
2.3	Edmonton Municipal Airport: 1945-2013	
2.4	Key Themes	
2.6.1	Aviation and Civic Identity: Edmonton as the Gateway to the North	
2.6.2	Canada and the War Effort: Infrastructure on the Home Front	
2.6.3	Pioneer Commerce and Industry at Edmonton Municipal Airport	
3	SITE & BUILDING EVOLUTION	25
3.1	Edmonton Municipal Airport: Site Evolution	
3.2	Hangar 11: Building Evolution	

Project # 19-021-01
Prepared by SW / PO / RL / AF /
AC / SR / EA

4	CULTURAL HERITAGE VALUE	32
4.1	Synthesis of Existing Evaluation of Significance and Integrity	
4.1.1	Analysis for Heritage Significance	
4.1.2	Analysis for Integrity	
4.2	Draft Statement of Significance	
5	HERITAGE POLICY REVIEW	40
5.1	Standards and Guidelines for the Conservation of Historic Places in Canada	
5.2	The Way We Grow: Municipal Development Plan (2010)	
5.3	Historic Resources Management Plan (2009) and Policy C450B	
5.4	City Centre Area Redevelopment Plan (2012)	

PART II: HISTORIC BUILDING RECORD: CONDITION ASSESSMENT

6	ASSESSMENT OF EXISTING CONDITION	46
6.1	Overview	
6.2	Building Modifications	
6.3	Existing Condition: Exterior Envelope	
6.3.1	Roof Systems	
6.3.2	Floor & Roof Structure	
6.3.3	Exterior Walls	
6.3.4	Windows	
6.3.5	Doors	
6.4	Existing Condition: Interiors	
6.4.1	Interior Finishes	
6.4.2	Hangar Floor	
6.4.3	Freight Elevator	
6.5	Existing Condition: Ancillary Structures	
6.5.1	Brick Chimney	
6.5.2	Fire Escapes	

PART III: HISTORIC BUILDING RECORD: CONSERVATION PLAN

7	CONSERVATION PLAN	93
7.1	Intent and Objectives	
7.2	Conservation Plan for Stabilization	
7.2.1	Stabilization Methodology	
7.2.2	Stabilization Scope	
7.2.3	Stabilization Follow Up	
7.3	Conservation Plan for Occupancy	
7.3.1	Conservation Methodology	
7.3.2	Primary Conservation Scope	
7.3.3	Secondary Conservation Scope	
7.4	Cost Estimates	
8	MAINTENANCE PLAN	108
9	FUTURE USE OPPORTUNITIES	109
9.1	Zoning for Hangar 11	
9.2	Options for Adaptive Reuse	
10	CONCLUSION	111
11	PROJECT PERSONNEL	112
12	REFERENCES	113
13	APPENDICES	118
A	Blatchford Advanced Assessment & Documentation (GEC Architecture)	
B	Class D Cost Estimate (Hanscomb Quantity Surveyors)	
C	Hangar 11 Conservation Drawing Set (ERA Architects)	
D	Alberta Building Code Review (GEC Architecture)	
E	Structural Testing & Analysis Report (RJC Engineers)	
F	Adaptive Reuse Precedents for Hangar 11 (ERA Architects)	
G	Site History to 1919 (ERA Architects)	



North-facing view of the former U.S. Army Air Force hangars, 1958. Hangar 11 is second from the front. (Photo RP303.1 appears courtesy of the Provincial Archives of Alberta)

EXECUTIVE SUMMARY

This Historic Building Record for Hangar 11 at 11760 109th Street Northwest, contains: a Site History, Context and Heritage Evaluation; an Historic Building Condition Assessment; and, a Conservation Plan.

Site History, Context and Heritage Evaluation

Hangar 11 is an aircraft hangar constructed in 1942-43 for the United States Army Air Force detachment at Edmonton's Blatchford Field. The hangar was used briefly to support the Northwest Staging Route, which systematically transferred aircraft and materials to Alaska to support the war effort on the Eastern Front. Hangar 11 was subsequently used for three decades by Northwest Industries Ltd., a local firm engaged in national military and commercial aircraft repair and development contracts.

Today, Hangar 11 remains at Edmonton's Blatchford Field, the decommissioned Edmonton City Centre Airport. The airport was Canada's first municipal airport, and during the Second World War, was the busiest in North America. Hangar 11 serves as one of the few remaining buildings that can yield evidence of Blatchford Field's local, national, and international heritage value.

Hangar 11 is listed on Edmonton's Inventory of Historic Resources. It is not currently included on Edmonton's Register of designated Municipal Historic Resources. It exists today within a policy context that encourages the City of Edmonton to retain, restore, and designate its historic resources (Historic Resources Management Plan, 2009) and that directs the Blatchford redevelopment to conserve and repurpose hangars on site (City Centre Area Redevelopment Plan, 2012), several of which have since been demolished.

Condition Assessment

Most of Hangar 11's existing supporting structure has been found to be in fair condition, with the exception of several areas, mainly in the west ancillary wing, which are in very poor condition and require extensive structural repairs. While the cladding and finishes

are generally in poor or defective condition, the central features of the building's character are intact with some degradation, including the building's unique timber structural frame and curved wood bowstring trusses. Overall, the building shows high potential for restoration and reuse.

Extensive restoration and rehabilitation work is required to prepare the building for occupancy. Existing non-structural cladding and finish systems will need to be upgraded and/or replaced, as will several building systems required for health/life safety, code compliance and building functionality. There are additional building-envelope breaches that require immediate attention.

Conservation Plan

The Conservation Plan outlines two potential conservation scenarios: one where the building is stabilized to allow for long-term mothballing by the City, and another where the building is prepared for occupancy. Scopes of work and cost estimates are provided in Section 7 for both options. Either option will allow the City of Edmonton to conserve Hangar 11's heritage value in the long term.

Adaptive Reuse Program

The adaptive reuse of Hangar 11 may be possible through a flexible approach to a variety of factors, including:

- Occupancy model - including one large occupant, or multiple smaller occupants;
- Stewardship/ownership model - including the City of Edmonton, an arm's-length agency, a non-profit organization, an educational institution, or a private company; and,
- Phasing model - including phased occupancy, which could allow for (a) reduced up-front costs and (b) opportunities to engage the public and generate broader interest in the building's reuse.

Hypothetical 'model' scenarios and relevant precedents for Hangar 11's adaptive reuse are included in Appendix F.

1 INTRODUCTION

1.1 Scope of the Report

The City has retained GEC Architecture in partnership with heritage consultant ERA Architects to develop an Historic Building Record, Historic Building Condition Assessment, and Conservation Plan for Hangar 11. The building is located at 11760 109th Street Northwest (“the Site”) on the former Edmonton Municipal Airport lands.

This report incorporates the Historic Building Record, Historic Building Condition Assessment, and Conservation Plan with supplementary conservation drawings.

This report was prepared with reference to the following:

- The Alberta Historical Resources Act;
- The Standards and Guidelines for the Conservation of Historic Places in Canada;
- City of Edmonton Policy C450B: To Encourage the Designation and Rehabilitation of Municipal Historic Resources in Edmonton;
- The City of Edmonton Historic Resources Management Plan (2009);
- The April 2017 Heritage Assessment of Hangar 11, by David Murray Architect in association with Next Architecture and Ken Tingley;
- The June 2009 Historic Impact Assessment: A Thematic Overview for City Centre Airport, by Ken Tingley;
- Edmonton Heritage Council letter to the Mayor and City Council (March 23, 2018);
- Edmonton Historical Board letter to the Mayor and City Council (May 1, 2018).

1.2 Site Description and Context

The Site consists of a single wood-frame industrial airplane hangar (Hangar 11), with a 2971 m² central open space covered by a curved roof, bordered on the east and west sides by three storeys of office space. The structure was built under the direction of the United States Army Air Force in 1942-43.

The east side features two single-storey ancillary extensions, one of which functions as a boiler room with an attached masonry chimney. The west side features a single-storey ancillary extension with three (formerly four) loading bays.

The Site is located on the west side of 109th St NW, within the former Edmonton Municipal Airport. The Airport is currently closed and sits as an open field prior to its impending subdivision and redevelopment.

Other remnant industrial airport buildings on the edges of the field include the Alberta Aviation Museum at Hangar 14 (11410 Kingsway NW), a double hangar at the field's west side off 121st St NW, and an industrial building currently serving Northgate Industries Ltd. at 12345 Yellowhead Highway, at the field's north side. Several remnant airport buildings are identified on Edmonton's Inventory of Historic Resources, and are discussed in Section 1.3.

The Northern Alberta Institute of Technology ("NAIT") campus is located immediately east of the Site, across 109th St NW, spanning between 118th Ave NW and the diagonal Princess Elizabeth Avenue.

1.3 Current Heritage Recognition

Hangar 11 is listed on Edmonton's Inventory of Historic Resources. Properties on Edmonton's Inventory of Historic Resources are recognized as meriting conservation, but are not legally protected under the *Alberta Historical Resources Act*.

The City of Edmonton also keeps a Register of Municipal Historic Resources. In contrast to those on the Inventory, Registered properties are legally protected from demolition or inappropriate alteration under Policy C-450B. A property must be designated a Municipal Historic Resource by Edmonton City Council in order to be on the Register. Hangar 11 is currently not included on Edmonton's Register of Municipal Historic Resources.

Nearby Historic Resources

Hangar 14 (the Alberta Aviation Museum) at 11410 Kingsway NW is the only designated Municipal Historic Resource and Provincial Historic Resource within the Site's vicinity. Hangar 14 is listed on Edmonton's Register of Municipal Historic Resources and on the Alberta Register of Historic Places.

There are four sites listed on the Inventory of Historic Resources (i.e. not designated as Municipal Historic Resources) located within the Site's vicinity:

- Hangar 8 (*demolished in 2016*);
- The Stanley Engineering Building at 11752 Kingsway Ave;
- The Northern Alberta Institute of Technology (NAIT) at 11762 106 St NW; and,
- The Northwest Industries Factory at 101 Airport Rd NW (*demolished*).

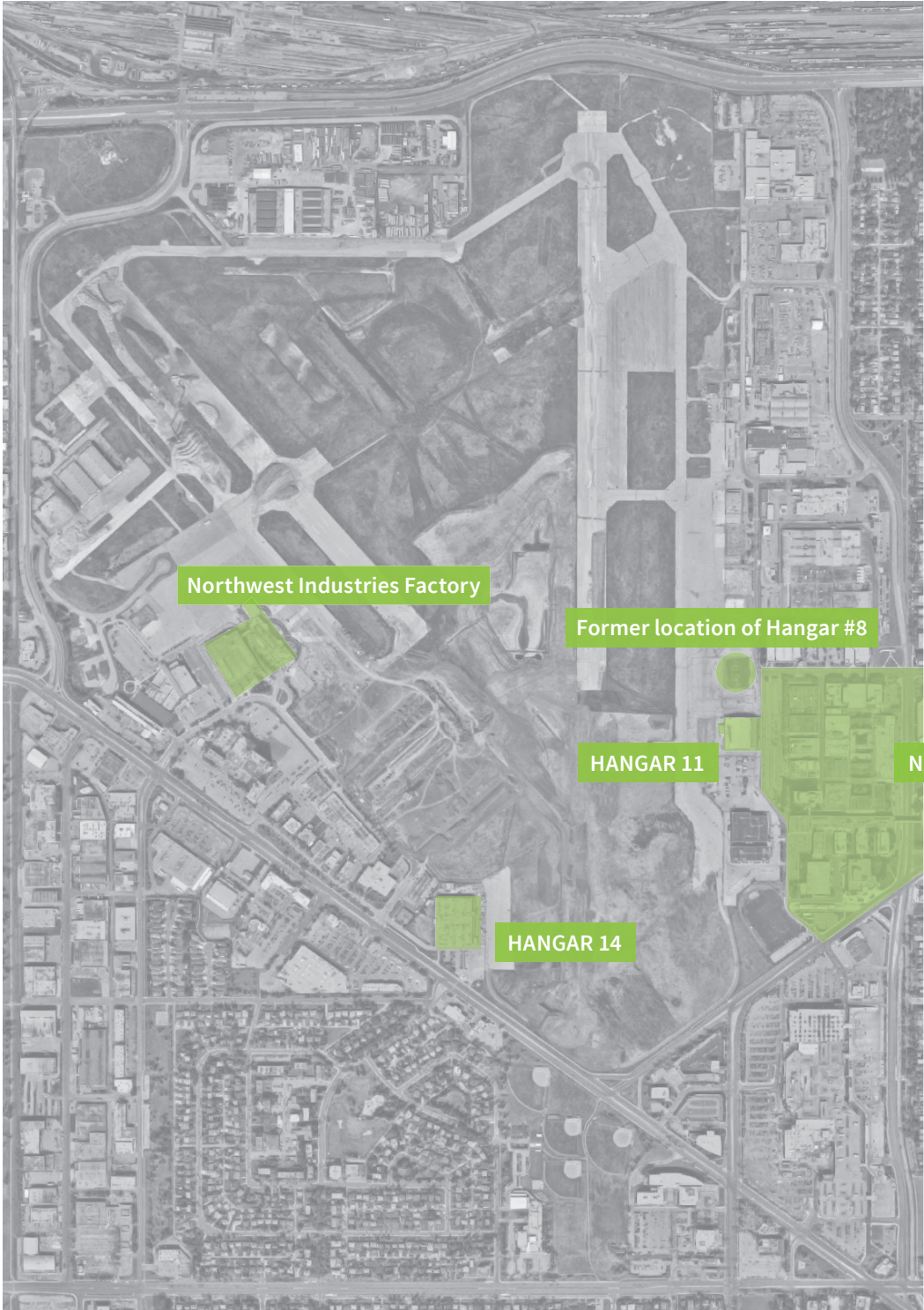

Nearby heritage resources (Google Maps 2019, annotated by ERA)

1.4 Project Description and Background

This report has been prepared in response to a request by Edmonton's City Council to develop an Historic Building Record, an Historic Building Condition Assessment, and a Conservation Plan for Hangar 11. The purpose of these reports is to assist in determining the viability of retaining the building for rehabilitation and future use.

Hangar 11's future has been uncertain since the 2013 closure of the Edmonton City Centre Airport. In 2012, the City of Edmonton released the City Centre Area Redevelopment Plan, which forecasted the redevelopment of the airport lands as a mixed-use neighbourhood.

As the City Centre Area Redevelopment Plan directed that the hangars on site be conserved where appropriate, the City of Edmonton undertook studies to determine Hangar 11's heritage value and existing condition. These studies occurred in early 2017, following the demolition of Hangar 8 in 2016. Hangar 8 had been located immediately to the north of Hangar 11.

While the April 2017 Heritage Assessment concluded that Hangar 11 had significant heritage value, the June 2017 Condition Assessment found that the building was in poor condition and would require conservation and stabilization.

In response to the uncertainty regarding Hangar 11's future and a pending land sale to the adjacent NAIT for its campus expansion, the Edmonton Historical Board and the Edmonton Heritage Council made submissions to Council in Spring 2018 in support of Hangar 11's conservation and adaptive reuse. Both groups provided adaptive reuse precedents involving hangars and similar structures.

On August 27th 2018, Edmonton City Council voted to delay the decision to demolish and sell Hangar 11 until further studies could be completed to clarify its physical condition and prospects for adaptive reuse.

ERA Architects and GEC Architecture have worked in partnership to develop this Historic Building Record, Historic Building Condition Assessment, and Conservation Plan to provide Edmonton City Council with the information required to determine Hangar 11's future.

1.4.1 Previous Studies and Reports

This report incorporates information from previous studies, including:

- *Historical Impact Assessment: A Thematic Overview Narrative for City Centre Airport*, by Ken Tingley (June 2009);
- *Hazardous Building Materials Summary Report*, by Golder Associates (June 2015);
- *Heritage Assessment of Hangar 11 at the former Edmonton Municipal Airport, Alberta*, by David Murray Architect in association with Next Architecture and Ken Tingley (April 2017); and,
- *Condition Assessment Report: Hangar 11*, by S2 Architecture, RJC Consulting Engineers, Smith + Andersen, and SMP Engineering (June 2017).

2 SITE HISTORY

This Site History reviews the context within which Hangar 11 was built, used, and ultimately left vacant following the closure of Edmonton City Centre Airport in 2013.

Throughout the site's history, the terminology used to describe the airport has evolved. Blatchford Field, Edmonton Municipal Airport, and Edmonton City Centre Airport are generally used interchangeably throughout this section.

A history of the site prior to 1919 is included in Appendix G.

2.1 Edmonton's Municipal Aerodrome: 1919-1939

The aftermath of World War One brought flight into Canadian consciousness. Aviation feats in Europe had been reported over the course of the war, and in the years that followed, it became apparent that aviation could serve more than military purposes.

In 1919, the Canadian government enacted the country's first aircraft operation regulations and widely encouraged municipalities to establish local aerodromes. The British Royal Air Force distributed decommissioned war planes throughout the Commonwealth to encourage the development of a culture and understanding of flying.

In Western Canada, like elsewhere throughout the Commonwealth, the earliest adopters were World War One veterans who were already familiar with flight. In Edmonton, Wilfred Reid May (known as "Wop" May) returned home and established May Airplanes Ltd. May had become well-known for his engagement with the German Red Baron, Baron von Richthofen at the Somme. The May brothers rented a Curtiss JN-4 Canuck from the City of Edmonton, and mostly found work in their early days performing aircraft stunts for an admiring public at town and country fairs throughout Alberta.

Captain Keith Tailyour, another celebrated World War One veteran, partnered with "Jock" MacNeill and a few others to establish the Edmonton Aircraft Company. Like May Airplanes Ltd., much of the Edmonton Aircraft Co.'s work came from stunt gigs, but the company was initially envisioned as an "air taxi service", proposing to carry passengers between centres like Edmonton, Calgary, and Lethbridge.

These early aviation firms required takeoff, landing, and aircraft storage facilities. They found ideal locations on farm lots to the city's northwest; these were generally flat, prairie-style fields with ample space.



A young "Wop" May, circa 1920 (Imperial War Museum).

The May brothers rented a farm on the St. Albert Trail, while Tailyour, MacNeill and their partners approached farmer John Hagmann, who owned two quarter sections of farm lot just north of the Hudson’s Bay Company reserve. They proposed to rent two acres of his southeast quarter section —called the New Hagmann estate, for a pre-WWI subdivision that was never built— for \$150 per year. They also paid to construct a 55x60ft hangar on the property. In June 1920, the Edmonton Aircraft Co. was posting ads in the Edmonton Journal inviting tourists to visit its aerodrome at the “top of Portage Avenue”.

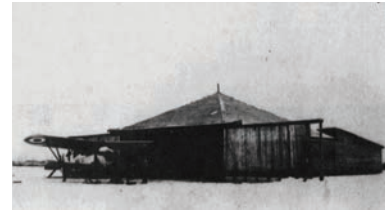

A 1920s photograph of the original hangar constructed at the aerodrome by Jock MacNeill and team (Edmonton Journal).

SEE EDMONTON FROM THE AIR



CAPT. KEITH TAILYOUR, A.F.C., will take up Passengers Daily from 2 to 9 p.m.
Other Trips by Special Arrangement

PHONE 2122 OR 82126
Aerodrome at Top of Portage Avenue.
Come and See the Famous Avro Machine

EDMONTON AIRCRAFT CO. LTD.

An advertisement in the Edmonton Journal on June 8, 1920. (Edmonton Journal).

Blatchford Field: Canada’s First “Public Air Harbour”

In 1924, the City was becoming aware of the need for better-equipped takeoff and landing zones. A 1924 crash by Wop May had prompted his team to petition the City of Edmonton for an appropriate aerodrome. City of Edmonton Mayor Kenneth Blatchford became an early and active proponent for the project.

City officials surveyed a number of sites throughout the city, and ultimately selected the existing private aerodrome established on the New Hagmann estate in 1920. The aerodrome still featured the single hangar built by Tailyour, MacNeill, and partners, and more recently, Wop May had been using the site for flights to and from Grande Prairie. The City acquired the hangar from Imperial Oil Co., which had purchased the building in 1921 for flight expeditions northward to its oil fields at Fort Norman.



Early proponents of aviation at Blatchford Field in 1927. The three men in the centre, from left to right, are A. W. Haddow, Edmonton City Engineer, “Wop” May, and MP Kenneth Blatchford (City of Edmonton Archives EA-10-2622).

On October 13th, 1924, Edmonton's City Council voted to set aside lands on the former New Hagmann estate and raise funds for a municipal aerodrome. On June 16th 1926, the Department of National Defence issued the City of Edmonton an official license to establish a public aerodrome - the first issued to a municipality in Canada.

The Deputy Minister for Defence sent the City an letter, noting that "the example by your city in establishing this flying field is one which I trust will be followed by every other city in the Dominion." The City voted to name the field for former mayor Kenneth Blatchford. The airfield was officially opened on January 8th 1927.

Aviation Activities at Blatchford Field

In the next fifteen years, Blatchford Field was used in various ways as part of the city's growing aviation industry. These ranged from recreation and air-stunt displays to the functional servicing of isolated communities.

The cities of Edmonton and Calgary both established Aero Clubs. In Edmonton, Wop May became the first president of the Edmonton and Northern Alberta Aero Club ("ENAAC"). ENAAC split responsibility with the City for the management of Blatchford Field; the City was responsible for maintenance and construction, while ENAAC managed all aviation activities. The Club functioned much as a recreational extracurricular organization; memberships were \$5 per year, and its goals were to foster an understanding of aeronautical sciences and engineering.

At Blatchford Field, public agencies and private citizens engaged in exploration around the limits of flying. In 1927, the RCAF used Blatchford Field to test winter flying. Between 1928 and 1930, Canada's postal service inaugurated a series of air mail routes, some of which occurred through Blatchford Field. Some of the most significant ventures from Blatchford Field represented Edmonton's emerging role as the "Gateway to the North".

Blatchford Field as the "Gateway to the North"

It had quickly become apparent that aviation offered a remarkable means of connecting places and communities to Canada's existing transportation infrastructure. Notably, various communities north of Edmonton, in the Yukon and the Northwest Territories, were at that time only accessible via weeks-long travel by dogsled.

One of the first attempts to use aircraft to access northern communities was undertaken by the Imperial Oil Company, which sought a more efficient way to access its oil fields at Fort Norman, now Tiluta, in the Northwest Territories. The 1921 journey was ultimately unsuccessful, but the idea took hold that flight could open up the North where it had been almost entirely inaccessible before.

Through the early years, smaller expeditions were able to demonstrate that Edmonton could effectively function as a base from which to service northern and other isolated communities. Examples included early airmail experiments like May-Gorman's stunt

delivery of the Edmonton Journal down to Wetaskiwin in 1919, and Wop May and Vic Horner's delivery of diphtheria medication to an isolated community experiencing an outbreak in 1929.

In the mid 1930s, Wilfred Leigh Brintnell's Mackenzie Air Service Ltd. (established 1931) offered regular transportation service to mining communities and trading posts in the Canadian northwest, from Edmonton to the Arctic. Like Tailyour and May, Brintnell was a World War One air force veteran who had been involved in a series of aviation ventures since his war service, quickly rising to a leadership position with Western Canada Airways in the late 1920s. In 1931, he left Western Canada Airways to establish Mackenzie Air Service, his own firm. At Blatchford Field, Mackenzie Air Service leased the machine shop, and in addition to rent, offered engineering assistance to other aircraft using the field.

Meanwhile, bush pilot Grant McConachie was operating commercial services from Edmonton to Fort St. John, Dawson Creek and Whitehorse, under his firm United Air Transport, later Yukon Southern Air Transport. As he delivered air mail along routes up to Yukon in the late 1930s, he yearned to fly from Edmonton to Shanghai; he imagined that the route would pass through Alaska, over the Bering Sea, and down Siberia's coast to China. Before he had the opportunity to do so, World War Two would begin and his knowledge of northern flight routes would prove useful in northward military ventures such as the Alaska Highway and the Northwest Staging Route.

Airfield Evolution: 1929-1939

In 1929, amidst ongoing pressure from the Edmonton and Northern Alberta Aero Club over the need for larger and improved facilities, City of Edmonton voters elected to fund airfield improvements and expansion. Edmonton City Engineer A. W. Haddow drew up plans which included a new heated hangar and airfield lighting, among other works. City Architect John Martland drew up the replacement hangar, which, while designed to be functional, included stylistic features like roof dormers typical of the period's residential architecture.

The new hangar was built by 1930, on the airfield's west edge just north of Portage Avenue (now Kingsway). The original 1920 hangar was demolished. The airfield's expansion of facilities would necessitate the hiring of a manager, as its operations had grown too large to continue to be managed by the volunteer Aero Club. The City of Edmonton hired Jimmy Bell as airfield manager, who would continue in the role for two decades and would oversee the airport's expansion from a small-scale recreational and commercial airfield to a major centre.

By 1937, Blatchford Field would again reach its capacity, and tenders would be issued for the construction of a second hangar, located immediately north of the first. Shortly afterward, Trans-Canada Airlines ("TCA") commissioned a third hangar, in a separate area off Portage Avenue, southeast of the two municipal hangars, for TCA's exclusive use.

Recently granted a monopoly over Canadian passenger air travel, TCA was making standard improvements to municipal airfields across the country.

As part of TCA's requirements, in 1937 the airfield needed to be expanded beyond its 59 hectares. Edmonton's City Council quickly acquired lands to the north and east of the existing airfield, expanding its borders to roughly the size of the current Blatchford Field area today. The 1937 expansion would prove critical in the war years to follow, when Blatchford Field would become North America's busiest airfield.



An early photo of the 1929 hangar on the west side of Blatchford Field, built 13 years before the U.S. Army Air Force hangars (including Hangar 11) on the airfield's east side (Peel's Prairie Provinces).

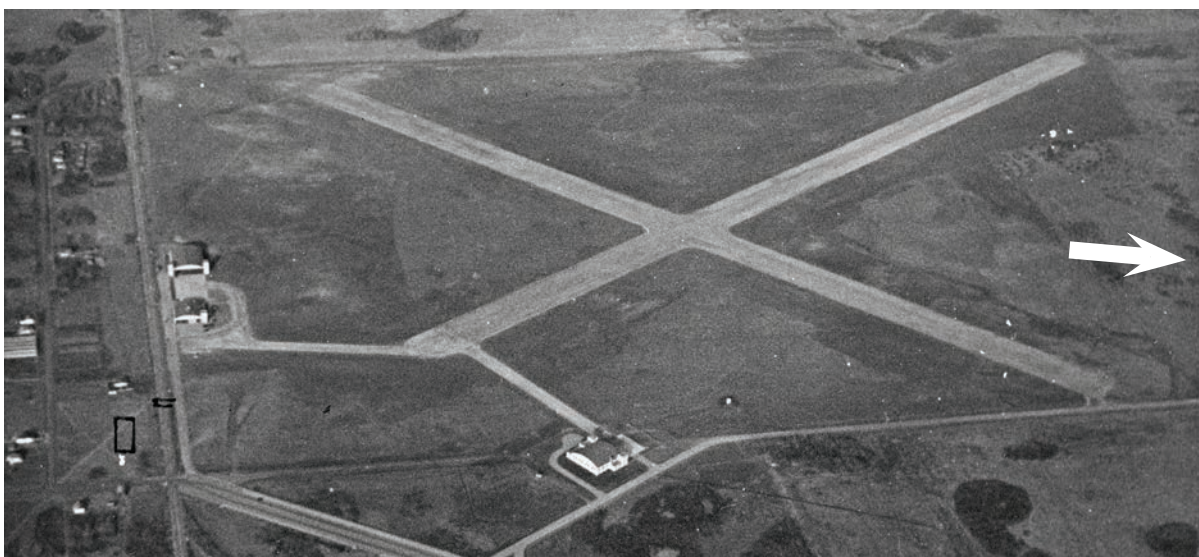

A north-facing aerial photograph circa 1939, showing the three pre-WWII hangars at Blatchford Field. Hangar 11 and the other American hangars would soon be constructed to the east, shown with a white arrow. The British Commonwealth Air Training Plan schools built their campus around the existing TCA hangar, near the bottom of the image. (Photo A11663 appears courtesy of the Provincial Archives of Alberta)

2.2 Blatchford Field during WWII: 1939-1945

When Canada declared war in the fall of 1939, Edmonton was prepared to support the war effort on the home front. The City of Edmonton offered Blatchford Field up to the federal government for its use.

Commercial firms continued to use Blatchford Field through the war years. In particular, TCA supported the RCAF in handling air-mail and passenger requirements, while in 1942, a new firm emerged from Canadian Pacific Rail's purchase of a number small-scale western bush pilots' companies. Grant McConachie would be named president of the new firm, Canada Pacific Airlines, which provided passenger routes between western Canadian centres. The airline would ultimately support the U.S. Army's northward ventures over the course of the war.

Blatchford Field became the main base for three major wartime programs, each located in its own section of the field: the British Commonwealth Air Training Plan schools at the south, Leigh Brintnell's private Aircraft Repair Ltd. at the north, and the U.S. Army Air Force's detachment and hangars at the east.

Below: A 1943 north-facing photo showing the locations of the various war-related activities occurring at Blatchford Field. Today's Hangar 11 is indicated with a white arrow. (City of Edmonton Archives, annotated by ERA)

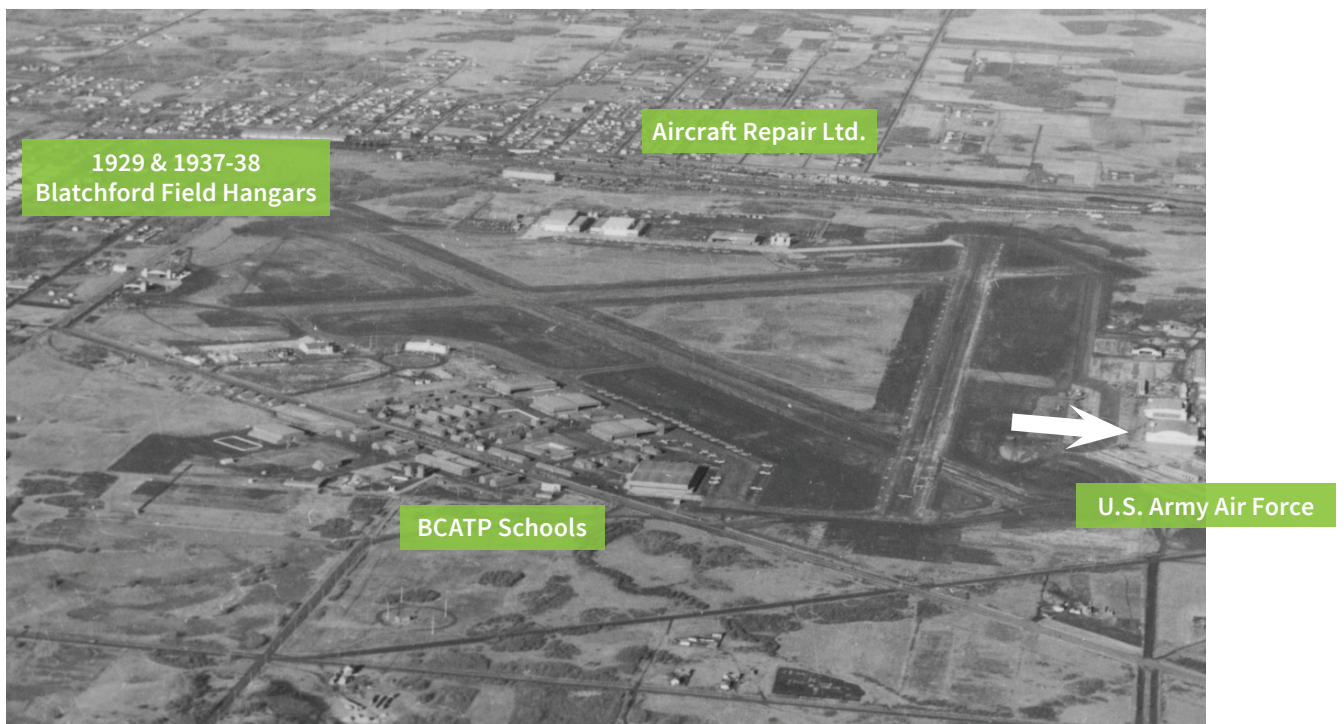

2.2.1 The British Commonwealth Air Training Plan: 1940-1944

In December 1939, the British Commonwealth Air Training Plan was established through a partnership between the Commonwealth countries of Canada, the UK, New Zealand and Australia. Over the course of the war, the program would serve trainees from all four countries and their allied nations.

Edmonton hosted two of the Plan's air schools at Blatchford Field: the No. 2 Air Observers' School, and the No. 16 Elementary Flying School. The Schools required fifteen new buildings and three hangars. These were quickly constructed in a complex at the airport's south end, on Kingsway (previously Portage Avenue) just southeast of the newly-built TCA Hangar.

The No. 2 Air Observers' School ("AOS") and the No. 16 Elementary Flying School ("EFS") offered different training programs: the EFS trained in basic navigation, gunnery, and flight, and the AOS trained navigators in mapping, reconnaissance, photography, meteorology, and wireless communications. The EFS operated at Blatchford until July 1942, while the AOS remained on site for two years longer, closing in July 1944.

When the British Commonwealth Air Training Plan's schools were no longer needed at Blatchford Field in 1944, its facilities would become available for use by the influx of American military personnel in Edmonton. Today, the Alberta Aviation Museum at Hangar 14 serves as a remnant of the British Commonwealth Air Training Plan's campus construction at Blatchford Field.



Aircraft repair at the No. 2 Air Observers' School (Provincial Archives of Alberta).



The Aircraft Repair Ltd. plant at the north end of Blatchford Field in the 1940s (Provincial Archives of Alberta).

2.2.2 Aircraft Repair Ltd.: 1936-1945

In 1936, Leigh Brintnell's firm, Mackenzie Air Service, looked to establish a maintenance facility for its own planes and other firms at Blatchford Field. In 1937, the service was incorporated as Aircraft Repair Ltd.

Two years later, the firm began to receive government contracts as damaged Royal Air Force planes were delivered to western Canada for repair. By 1941, Aircraft Repair Ltd. was in the process of constructing large-scale facilities at Blatchford Field's north end, with easy access to a railway spur from which it could retrieve damaged planes arriving for repair.

Throughout the war, Brintnell's firm employed 3,000 locals, many of whom were women, as the contracts continued to flow in. Aircraft Repair Ltd. was ultimately recognized as the most active repair facility throughout the Commonwealth, and Leigh Brintnell would be awarded the Order of the British Empire for his work in organizing the firm. In 1945, Aircraft Repair Ltd.'s corporate structure would be reorganized as Northwest Industries Ltd.

2.2.3 The U.S. Army Air Force and the Northwest Staging Route: 1942-1944

In August 1940, prior to the United States of America's entrance into the war, Canada and the U.S. announced the establishment of the Permanent Joint Board on Defence, the first overt joint military program between the two countries. While the U.S. was not yet engaged in World War Two, both countries sensed the need to develop a plan for the Western Hemisphere's defence.

It was under the Permanent Joint Board on Defence that a program was established to connect northern American bases up to those in Alaska in order to supply a far-eastern front, and to ensure the North American west coast's defence. This would be carried out through three major programs: the Alaska Highway (a land-based route), the Canol Pipeline (an oil-fields connection), and the Northwest Staging Route (a series of landing strips along the Alaska Highway that would enable the transport of goods, including airplanes, and services by flight).

Edmonton, as the "Gateway to the North", became a major centre in the development of these three routes. American military personnel and two large private firms flowed into the city, which began to serve as the staging zone for all materials headed north. Canada established a Special Commissioner for Defence Projects in the North West, Major-General W. W. Foster, who was tasked with overseeing American operations and ensuring that Canadian sovereignty was not trampled throughout the cooperative process. The influx of American servicemen, officials and contracts caused a strain on Edmonton's housing market, but boosted its agriculture-dependent economy over the course of the war.

The Northwest Staging Route

The Northwest Staging Route functioned as a series of terminals spanning an air distance of 1700 miles between Edmonton and Fairbanks, Alaska. Many of the landing strips pre-dated World War Two and had been used by bush pilots such as Grant McConachie since the mid-1930s. In 1940, the Permanent Joint Board on Defence directed that these airfields be upgraded to support regular and extensive use.

The goal of the Northwest Staging Route was two-fold:

- to supply American air bases in Alaska with the materials and personnel required to defend themselves and to launch military operations; and,
- to shuttle products (airplanes and other weaponry) to the USSR, via Fairbanks as per the terms of the Lend-Lease agreement between the U.S. and the Soviet Union.



Lend-lease planes bound for the Soviet Union in storage at the Aircraft Repair Ltd. plant (Alberta Aviation Museum).

At Blatchford Field, aircraft were staged prior to their shipment up the supply line to Fairbanks. In November 1943, Gordon McCallum reported from Edmonton for the *Globe and Mail*:

Marked with the Red Star of Russia, American-made lease-lend bombers and fighters are being flown to the Eastern front by way of Edmonton, Alaska and Siberia in a growing stream. They pass through here every few days, with guns sticking out of their noses and live ammunition aboard ready to start at once in the task of blasting the Nazis from the land of the Soviets.

U.S. ferry pilots bring the planes from the factories to Edmonton and take them along Northwest Canada's chain of inland airports to Fairbanks, Alaska. There they are taken over by the Russians and flown to a new airport built by the Russians near Fairbanks. The planes are then serviced by Russian women air mechanics and put in shape for the long flight over the Bering Straits and Siberia.

From Edmonton the planes fly to Grande Prairie, Fort St. John, Fort Nelson, Watson Lake, Whitehorse and then on to Fairbanks, Alaska. The distance between fields is comparatively short, providing emergency landing facilities and allowing for short hops by craft with a limited range.

According to reports heard here a great number of the Russian pilots are women.

The new route has cut weeks from the time needed to deliver American-made planes to our Russian allies. Some observers estimate the planes are ready for combat 48 hours after leaving Edmonton.

As far as known, there hasn't been any published indication of the number of airplanes flying the route to Russia. But it is known that United States promises of help to Russia have been extensive, and certainly every man on the street in Edmonton who looks higher than the buildings around him has realized that the assistance to the Allies in the Far East has been great indeed.

Throughout the war, the Northwest Staging Route sent over 7,000 aircraft to the Soviet Union: 2491 in 1943, 3148 in 1944, and 2143 in 1945.

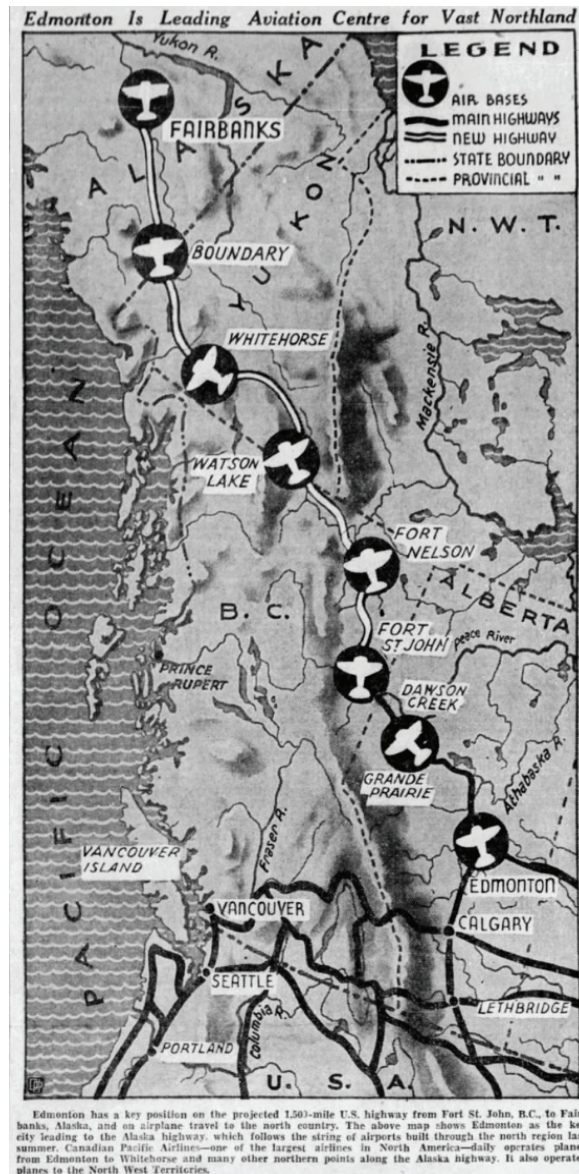

A map of the Northwest Staging Route published in the *Edmonton Journal* on October 20, 1942 (*Edmonton Journal*).

The American Detachment at Blatchford Field

The Northwest Staging Route was lightly used in the first two years of the war, but following the December 1941 Japanese attack on Pearl Harbor, the Americans in Edmonton arrived in significant numbers. Thousands of American military personnel, civilian contractors and government administrators would settle in Edmonton and elsewhere throughout Canada's northwest as they undertook the major projects required to serve the war front.

In 1942, the American North West Service Command established a detachment on the east side of Blatchford Field. The U.S. Army Engineers undertook the urgent construction of four hangars, barracks and quarters for over 2,000 military personnel, training spaces, storage spaces, and other miscellaneous buildings. It was during this rapid phase of development that Hangar 11 was constructed.

The speed with which the complex was developed is indicative of the immediate need for American military accommodations. A 1944 *Edmonton Journal* article reported that the Coast Construction Co. had retroactively taken out a building permit in the name of the United States Engineers for the construction of 53 buildings including hangars, warehouses, and sleeping quarters. The work was valued at \$1,314,000.

By 1944, the Americans' airfield needs had exceeded Blatchford Field's capacity. The U.S. Army Air Force undertook the construction of an air base just outside of the city at Namao. In 1944-45, the American detachment vacated its briefly-used complex of buildings at Blatchford Field, and moved all operations to Namao following its completion in September 1944. After the American detachment's departure, Blatchford Field manager Jimmy Bell was awarded the Medal of Freedom for his management of the airfield through its use by the U.S. Army Air Force for the Northwest Staging Route.



A 1942 photograph shows the general future site of the American detachment (highlighted in green) with only the first few buildings constructed. The future site of Hangar 11 is indicated with a white arrow (City of Edmonton Archives, annotated by ERA).

2.2.4 Hangar 11 Design and Construction

The 53 buildings at the American detachment at Blatchford Field were constructed between 1942 and 1943. They included four hangars located on the west side of 109th Street Northwest. The hangars were identified on a map of the Blatchford base, from north to south, as Hangars T1, T2, T3 and T4. Hangar 11 was originally known as Hangar T3.

All four hangars were constructed with ancillary wings and a central open hangar space, but they were not built identically. Hangars T1, T3 (Hangar 11), and T4 all featured arched roofs, while Hangar T2 featured a low-pitched roof. Other hangars built concurrently at Blatchford Field and elsewhere featured flat roofs. The arched roof style was consistent with the 1929 and 1937-38 hangars built at the west side of Blatchford Field.

While the U.S. Army Air Force directed that the detachment's hangars be constructed of steel, there was an understanding that time constraints and wartime supply limits might require the use of alternative materials. Ultimately the American hangars were constructed of structural timber.

Archival photos indicate that these first two hangars were Hangars T2 and T3 - the centre two in the line of four. They also indicate that the hangars were built office-wings first, followed by the construction of the central hangar space.

Hangar T3 (Hangar 11) was built with two ancillary single-storey extensions on its east side, which extended beyond the east office wing. The northern ancillary wing, at the building's northeast corner, was built as a boiler room with a masonry chimney. This appears to have been a unique feature among the four American hangars. A control tower was installed atop what appears to be the freight elevator overrun in Hangar 11's west office wing.

Around the time when Hangar 11 was transferred to Northwest Industries Ltd. following the 1944 departure of the American detachment (see Section 2.5), a four-car loading bay would be constructed off the building's west (airfield-facing) side, with an ancillary single-storey pitched-roof extension attached to the loading bay.

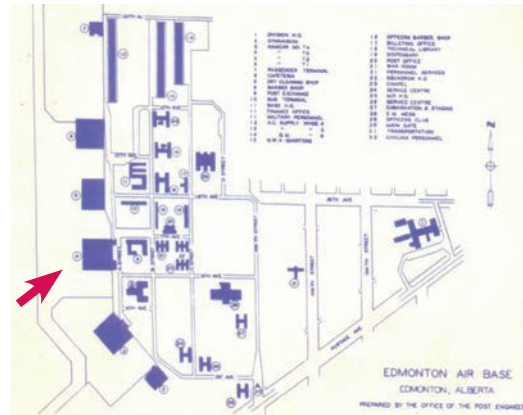

A map provided to American servicemen and women upon their arrival at the U.S. Army Air Force Base at Blatchford Field in the early 1940s. Today's Hangar 11 is indicated with a red arrow. (From Tony Cashman's *Gateway to the North*, annotated by ERA).



A south-facing photograph of the American military detachment on the east edge of Blatchford Field, c. 1945. Today's Hangar 11 is indicated with a red arrow (City of Edmonton, annotated by ERA).



A 1943 photo shows Hangars T2 and T3 constructed, and the office wings for Hangars T1 and T4 already in place. Hangar T3 (Hangar 11) is indicated with a red arrow. (City of Edmonton).

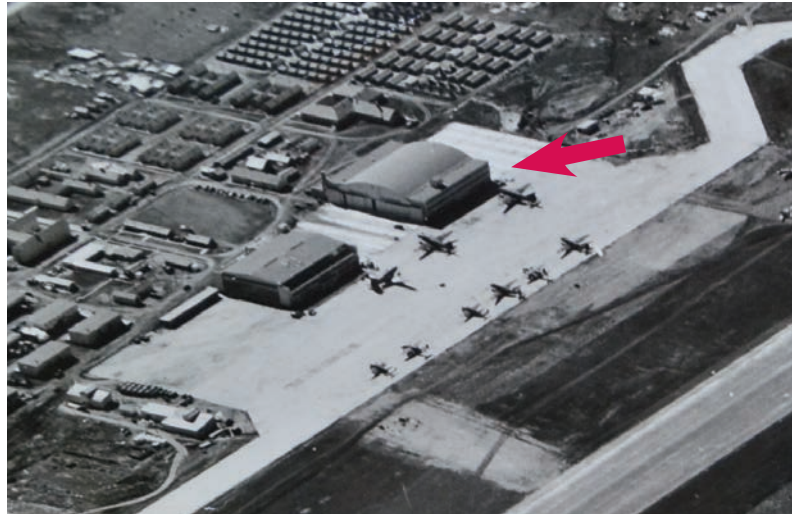

A southeastward-facing aerial view of the first two hangars constructed at the American detachment: Hangars T2 and T3 (now Hangar 11). Hangar 11 is indicated with a red arrow. (City of Edmonton, annotated by ERA).



A westward-facing aerial view of Hangars T2, T3 (Hangar 11) and T4 in 1943. Hangar T1 not yet constructed. Hangar 11 is indicated with a white arrow. (City of Edmonton, annotated by ERA).

Hangar 11 Architect

Earlier reports have noted that Hangar 11 was designed by local Edmonton architect George Heath MacDonald, and constructed by contractor H. G. MacDonald.

There is inconclusive evidence that George Heath MacDonald designed the four American hangars. The only primary-source reference to MacDonald as the architect for the U.S. Army Air Force projects is a July 17 1942 report at *Library and Archives Canada*, described as follows in Tingley's 2009 *Historical Impact Assessment for City Centre Airport*:

“G. L. McGee, Supervising Engineer of Aerodromes, visited Edmonton on 26 June 1942, and visited H. G. MacDonald, the architect and building contract for the US Army projects [note that the architect G. H. MacDonald and the contractor H. G. MacDonald appear to be conflated here]. After inspecting the building site, McGee arranged for MacDonald to lay out the work.”

There is no confirmation that MacDonald designed the four hangars on site. The Coast Construction Company would ultimately take out the retroactive building permit for the construction of the 53 buildings at the American detachment in 1944, perhaps indicating that Coast Construction served as the contractor rather than H. G. MacDonald.

Hangar T2 (immediately north of Hangar T3/Hangar 11), one of the first two to be constructed, also features a distinctly different design from the other three American hangars, with a low-pitched roof rather than an arched roof. This may have been a question of functionality, but may also be the mark of a different designer. George Heath MacDonald may have designed this first hangar, and not the following three.

The *April 2017 Heritage Assessment of Hangar 11* notes that George Heath MacDonald designed Hangar 11 by citing City of Edmonton Building Permit #1841, dated to November 17 1941. This was a Dominion Government permit for Assembly Plant Buildings to be built at the Airfield, with G. H. MacDonald as architect and H.S. MacDonald as contractor. In light of the Coast Construction Co.'s building 1944 permit for the American detachment buildings, however, it seems unlikely that Building Permit #1841 for Assembly Plant Buildings refers to the American hangars.

George Heath MacDonald and H.G. MacDonald were responsible for other war-era buildings at Blatchford Field; they are recorded in the R.A.I.C. Journal as architect and contractor for a 1941 major addition to the Assembly and Repair Shops at Aircraft Repair Ltd (which may be the construction referenced in Building Permit #1841), and in the *Edmonton Journal* as architect and contractor for the No. 2 Air Observers' School extension at 119th St. and Kingsway (the southwest corner of the airport).

2.3 Edmonton Municipal Airport: 1945-2013

At the end of the Second World War, the federal Department of Transport and the City of Edmonton reclaimed the facilities built for the war effort. The City of Edmonton resumed administration of Blatchford Field, by then called the Edmonton Municipal Airport.

Northwest Industries Ltd.

Aircraft Repair Ltd. continued to operate its facilities at the airport's north end, but in 1945, Leigh Brintnell's company was reorganized as Northwest Industries Ltd. The company continued to receive military contracts to manufacture, repair and modify aircraft over the next several decades.

In 1956, Northwest Industries expanded its business to introduce a Commercial Aircraft Service, which would supplement its military aircraft work by providing "full maintenance, repair, overhaul, servicing, modification and conversion facilities for the many civil operators whose base or port of call is Edmonton. These include oil and pipeline operators, owners of executive aircraft, commercial airlines and freight carriers to the far North..." (Flight Magazine, August 24 1956).

To house its Commercial Aircraft Service and expand its services, Northwest Industries acquired the hangars on the east side of the airfield which the Americans had built adjacent to their complex during the war. It may have been Northwest Industries, in the late 1940s, that constructed the single-storey loading bay additions on the hangar's west side which were not original to the building. In 1956, the hangar also temporarily accommodated the operations of Northwest Industries' instruments and electronics laboratory in its ancillary office spaces following a fire at their facility.

Below: A view of the west (airfield-facing) side of Northwest Industries' newly-acquired hangar on the Edmonton Municipal Airport's east side, today known as Hangar 11 (Flight Magazine).

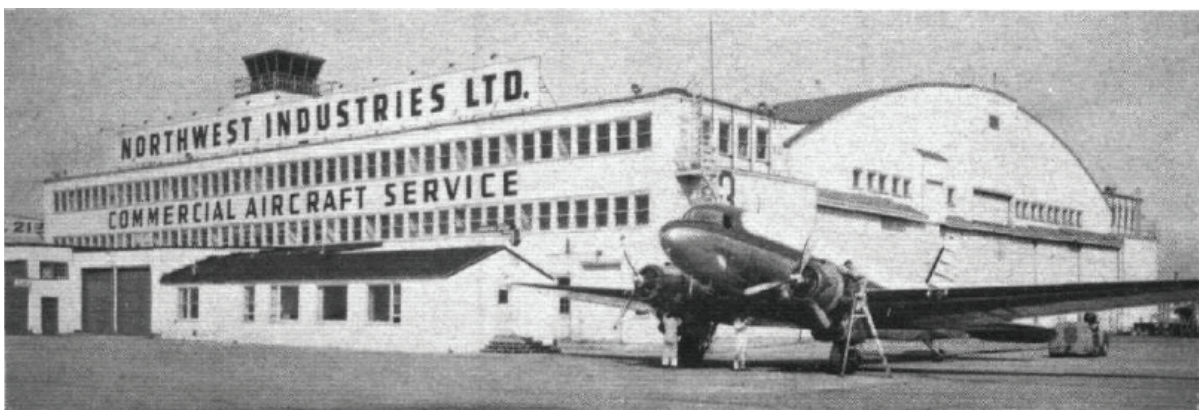

By the mid-1950s, Northwest Industries' presidency had passed from Leigh Brintnell to Francis G. Winspear, an Albertan business mogul who served as president/CEO for at least 19 businesses over his mid-20th-century career.

Winspear played an instrumental role in the firm's economic resurrection following a post-war decline. In 1961, under his direction, Northwest Industries proposed to offer commercial air services beyond its manufacturing functions, proposing to take over several existing Trans-Canada Airlines and Pacific Western Airlines routes between cities throughout the Prairies.

The following year, Northwest Industries was sold to Canadian Aviation Electronics Ltd. of Montreal, but would continue to operate as Northwest Industries Ltd. well into the 1990s. In 1982, under president Larry Prokop, Northwest Industries moved from its facilities at the Edmonton Municipal Airport to the Edmonton International Airport, which had been constructed in the 1950s. Northwest Industries would briefly return to the Municipal Airport in the early 1990s, in an expansion from the International Airport. After the 1980s, however, its large-scale facilities were no longer used by the company.

In 1999, airplane kit businessman Art Breier purchased the vacant Hangar 11 from the City Centre Airport Authority. Over the course of the next four years, he rented space to 42 small businesses, the majority of which were aviation related, but also included paintball and holistic healing services.



An undated view of Hangar 11 (foreground) and the hangar to the south, both occupied by Northwest Industries (City of Edmonton).

Decline of the Edmonton Municipal Airport

In the early 1950s, the City of Edmonton broke ground on a new International Airport. Through the 1950s, large modern airplanes had started to land at Namao Air Base because the runways at the Municipal Airport were too small, but there was limited room for runway expansion at the Municipal Airport.

The Municipal Airport continued to be used for short- and medium-range routes, and for commercial freight services. In the early 1960s, it was renamed the Edmonton Industrial Airport, and three decades later would be renamed once again as the Edmonton City Centre Airport.

The early 1960s saw Pacific Western Airlines offering \$11 flights to and from Calgary, which operated much like bus services; travellers could arrive at the airport, purchase a ticket, and fly between cities. By the mid-1970s, it had become clear that this convenience was allowing local travellers to bypass Edmonton's International Airport and was funnelling passengers to use Calgary's international services instead. Edmonton, a major early aviation centre, was declining in significance along international flight routes.

By the 21st century, Edmonton City Centre Airport was barely in use, and the City of Edmonton in 2008 conducted a study on reuse potential for the Blatchford Field lands. Debate ensued over the next several years, ultimately resulting in the airport's phased closure, concluding in 2013.

Today, the historic Blatchford Field lands are in the process of redevelopment as a mixed-use neighbourhood.

2.4 Key Themes

2.4.1 Aviation and Civic Identity: Edmonton as the Gateway to the North

Throughout its history, Blatchford Field/the Edmonton Municipal Airport played a key role in Edmonton’s position as the “Gateway to the North”. Hangar 11 directly served the war effort as it was constructed to support the Northwest Staging Route.

As the largest municipality on the edge of Canada’s northern communities, Edmonton served as the point of departure for north-facing operations, including basic deliveries (e.g. airmail, medications), northward expeditions, and military operations.

The establishment of Blatchford Field between 1919-1926 is connected to the post-World War One democratization of aviation and a growing awareness of its potential to address geographical isolation.

World War Two solidified Edmonton’s role as the “Gateway to the North”, as the city was used as the southern base for operations of the Permanent Joint Board of Defence that connected Alaska’s western boundary to the military action in Europe and Asia. Edmonton was engaged as the base for the Alaska Highway, the Canol Pipeline, and the air-based Northwest Staging Route.

In the half-century that followed World War Two, as commercial aviation was modernized and local and intercontinental passenger routes developed, Edmonton continued to serve as a layover city on routes to northern communities. It continues to serve this function today.

As one of four hangars built for the WWII-era American detachment at Blatchford Field, Hangar 11 is representative of Edmonton’s role serving the north in the decades before northern communities became more accessible by modern flight. The hangar was used for staging of airplanes and materials to be sent northward to Alaska to serve the eastern front.



A sign in Edmonton marking the start of the Alaska Highway, c. 1940s (Provincial Archives of Alberta).

2.4.2 Canada and the War Effort: Infrastructure on the Home Front

During both World Wars, as Canadian communities sent the majority of their young men and some women to the European front, those left at home organized en masse to support the war effort on the home front. Blatchford Field during World War Two became the centre of activities supporting the Allied war effort. These activities included:

- Military training at the No. 2 Air Observers' School and the No. 16 Elementary Flying School;
- Aircraft maintenance and repairs at Aircraft Repair Ltd.;
- The establishment of an Edmonton base for the joint Canadian-American Northwest Staging Route; and,
- The field's use as a base for both commercial aviation firms like Canadian Pacific Airlines and Trans-Canada Airlines enlisted to assist with the war effort, and for initiatives like Wop May's aircraft rescue service intended to assist along the Northwest Staging Route.

Like elsewhere on the home front, Blatchford Field saw local women engaged in manufacturing and repair work while the men who would have historically worked their jobs were enlisted abroad.

The American military complex at Blatchford Field was established to urgently provide staging space and administrative support for the transfer of aircraft to the USSR at Fairbanks, Alaska. Much of the American detachment's construction is indicative of this urgency: the building permit for its 53 structures was awarded retroactively, the buildings were constructed over less than a year's time, and notably, they were constructed of wood which was immediately available, rather than using preferred building materials like steel.

Hangar 11 is representative of Canada's role in the war effort on the home front. Its construction is indicative of the urgency with which the U.S. Army Air Force developed facilities in Edmonton, and it served a critically important wartime role staging aircraft on their way to Alaska in service of a greater intercontinental military operation between the Americans, Canadians, and the Soviet Union.



A north-facing aerial view of the American detachment at Blatchford Field in 1943. Two hangars are completed, with a third to the north under construction; Hangar 11 is the furthest south, at the right edge of the photo, and is indicated with a red arrow. (City of Edmonton, annotated by ERA)

2.4.3 Pioneer Commerce and Industry at the Edmonton Municipal Airport

From its establishment in 1919-1920 to the final years of the Edmonton Municipal Airport, Blatchford Field and Hangar 11 served as the base for industrious local commercial activity by aviation pioneers and those that followed.

The airport was initially established by groups of aviation pioneers looking for places to take off, land, and store their aircraft. These groups successfully lobbied the City of Edmonton to establish Blatchford Field in 1926 as Canada's first municipal airport and supported its early operations via volunteer management as the Edmonton and Northern Alberta Aero Club.

Aviation pioneers like Wop May and Grant McConachie laid the groundwork for Edmonton's role as the World War Two "Gateway to the North". The routes employed by the Northwest Staging Route had been first established by innovators like McConachie on their travels north through the 1930s.

Edmonton's early aviation pioneers were widely involved in the World War Two effort on the home front, assisting with commercial transport, Air Observers' School training, aircraft repair and Northwest Staging Route rescues, all based out of the Edmonton Municipal Airport.

Following World War Two, the newly-built Hangar 11 was used to support similarly industrious home-grown commercial activity. Soon after Leigh Brintnell's Aircraft Repair Ltd. became Northwest Industries Ltd., the company acquired the American hangars on the airfield's east side, and used them as a base for a Commercial Aircraft Service, expanding beyond military contracts to provide repairs and modifications for aircraft owned by commercial firms.

In its use by Northwest Industries Ltd. for over three decades following the Second World War, Hangar 11 represented a long-standing tradition at the Edmonton Municipal Airport of local, home-grown aviation firms playing major roles on the national and international stage.



Grant McConachie's Yukon Southern Air Transport infrastructure can be seen set up outside the 1929 hangar, at Blatchford Field's west side, in the 1930s (Photo A5305 appears courtesy of the Provincial Archives of Alberta).

3 SITE & BUILDING EVOLUTION

3.1 Edmonton Municipal Airport Site Evolution

1926: Blatchford Field is licensed as Canada's first municipal airport.

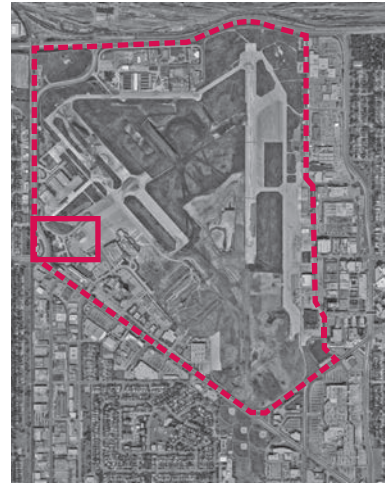

Above: Contemporary aerial showing the 1926 aerodrome property in red, and the complete former Edmonton Municipal Airport boundary in dashed red. (Google Maps, annotated by ERA)

Left: 1926 map showing the aerodrome. (Peel's Prairie Provinces)

c. 1939: Blatchford Field has been expanded to 3 hangars and well-kept runways.



c. 1939 photo showing the three hangars constructed in 1929 and 1937-38. (Provincial Archives of Alberta)



Contemporary aerial showing the 1939 aerodrome property in red, and the complete former Edmonton Municipal Airport boundary in dashed red. (Google Maps, annotated by ERA)

1942: The British Commonwealth Air Training Plan schools have been established on the north side of Kingsway, at the airfield's south end, and Aircraft Repair Ltd. has built a plant at the airfield's north end, adjacent to the railway.



1942 northwest-facing aerial photograph. Several hangars have been added to the airfield at the British Commonwealth Air Training Plan school and the Aircraft Repair Ltd. plant (City of Edmonton Archives)



Contemporary aerial showing the 1942 airport in red, and the complete former Edmonton Municipal Airport boundary in dashed red. (Google Maps, annotated by ERA)

1942-43: The U.S. Army Air Force's North West Service Command has built a detachment at the airport's east edge, which includes 4 hangars, barracks and support buildings.



1943 north-facing aerial photograph, with a red arrow indicating Hangar 11, visible for the first time. (City of Edmonton Archives)



Contemporary aerial showing the 1943 airport in red, and the complete former Edmonton Municipal Airport boundary in dashed red. (Google Maps, annotated by ERA)

1945: The North West Service Command's buildings remain, but the U.S. Army Air Force has relocated operations to its new air base at Namao, north of the city.



1945 northwest-facing aerial photograph (City of Edmonton Archives EA-160-260)



Contemporary aerial showing the 1945 airport in red, and the complete former Edmonton Municipal Airport boundary in dashed red. (Google Maps, annotated by ERA)

1948: Edmonton Municipal Airport takes on its current proportions and fulfills post-war commercial airport needs.



1948 north-facing aerial photograph (City of Edmonton Archives EA-10-2344)



Contemporary aerial showing the 1948 airport in red, and the complete former Edmonton Municipal Airport boundary in dashed red. (Google Maps, annotated by ERA)

1960: Edmonton Municipal Airport continues to evolve and be maintained as a contemporary municipal airport.



1960 northeast-facing aerial photograph (City of Edmonton Archives EA-10-3135)



Contemporary aerial showing the 1960 airport in red, and the complete former Edmonton Municipal Airport boundary in dashed red. (Google Maps, annotated by ERA)

3.2 Hangar 11 Building Evolution

The following diagrams demonstrate Hangar 11's physical evolution. Sections are highlighted in green when they exist during the corresponding time period, while sections in white have not yet been built, or have since been demolished.

1942-43: Newly Constructed. The building does not yet feature a control tower, boomtown-style signage, nor loading bays on its east side.

Southeastward View

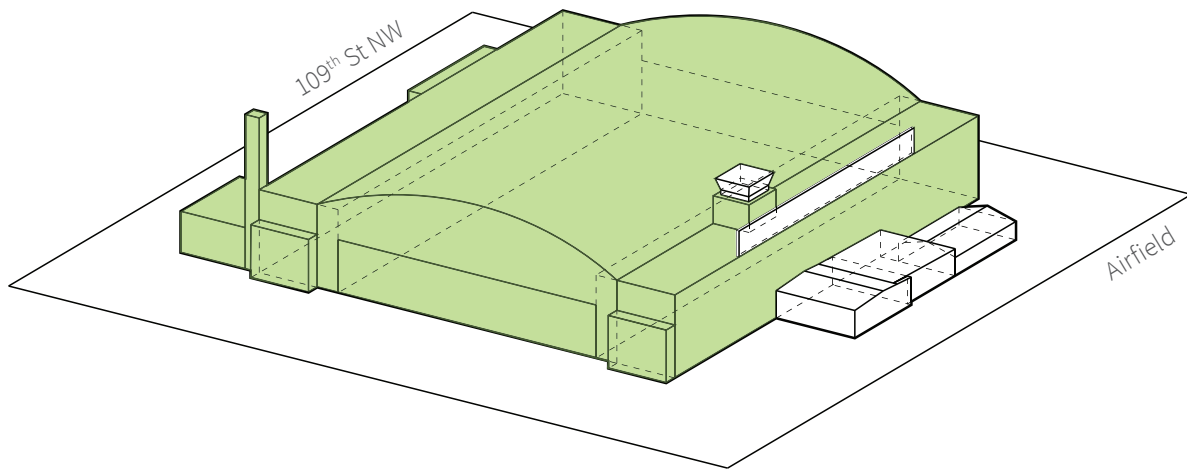

Northwestward View

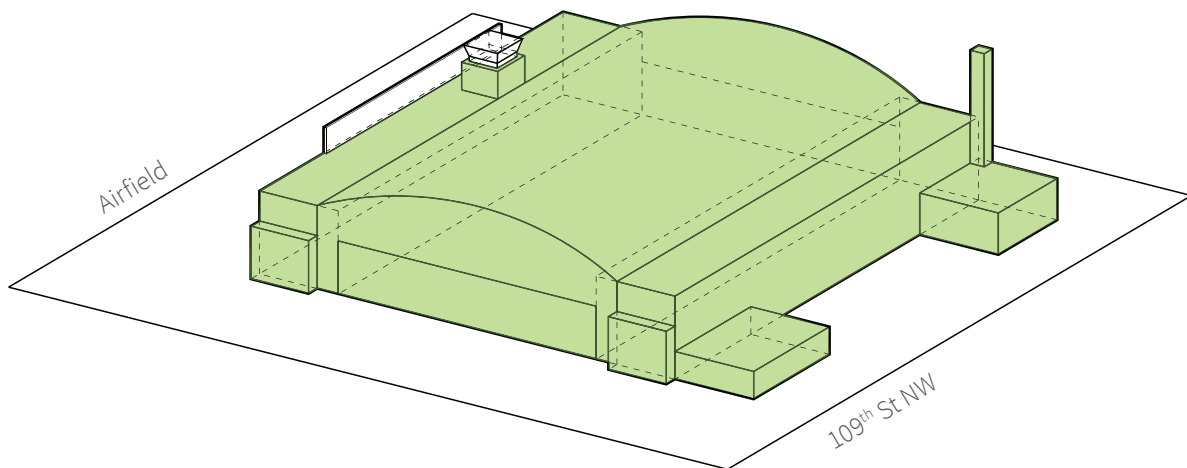

Late 1940s: Transfer to Northwest Industries Ltd. Features installed include a four-car loading bay and extension, a control tower atop what appears to be a mechanical penthouse, and a boomtown front-style Northwest Industries sign.

Southeastward View

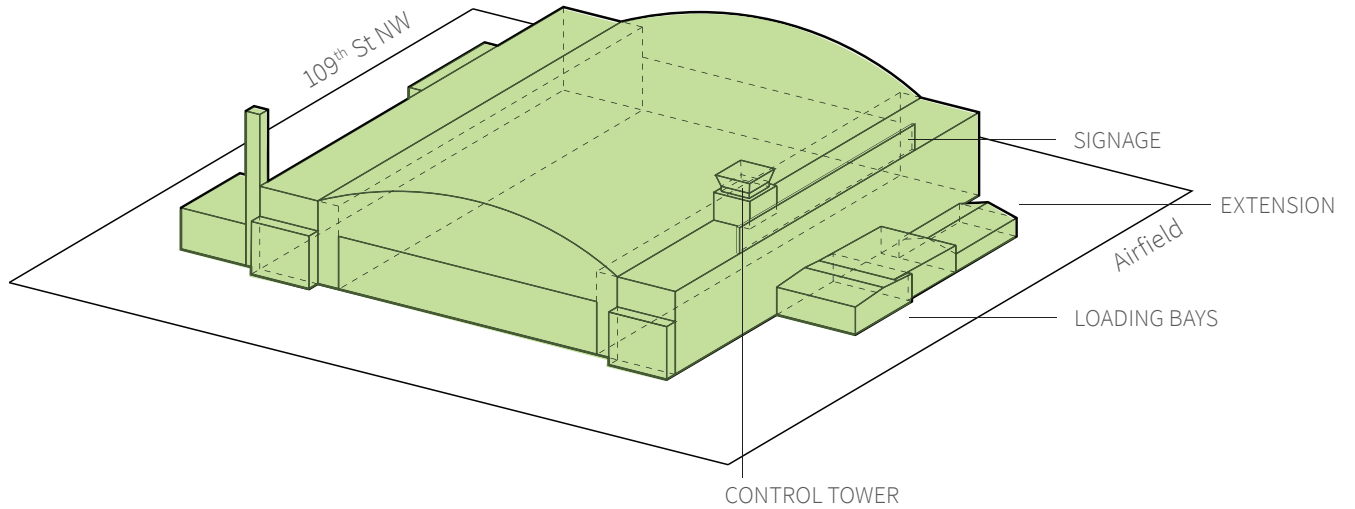

Northwestward View

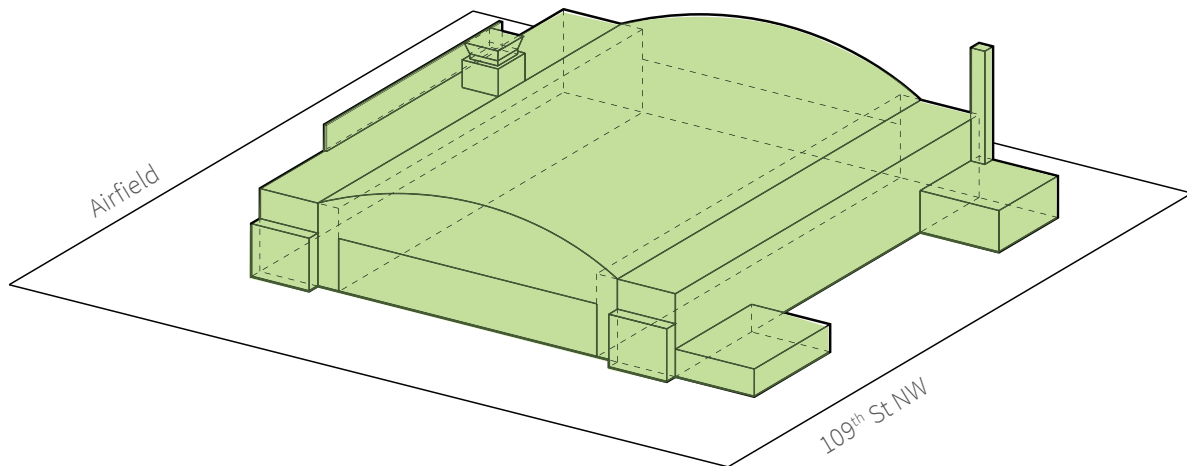

Present Day: Vacant. Signage, control tower, and extension on the loading bay have been removed.

Southeastward View

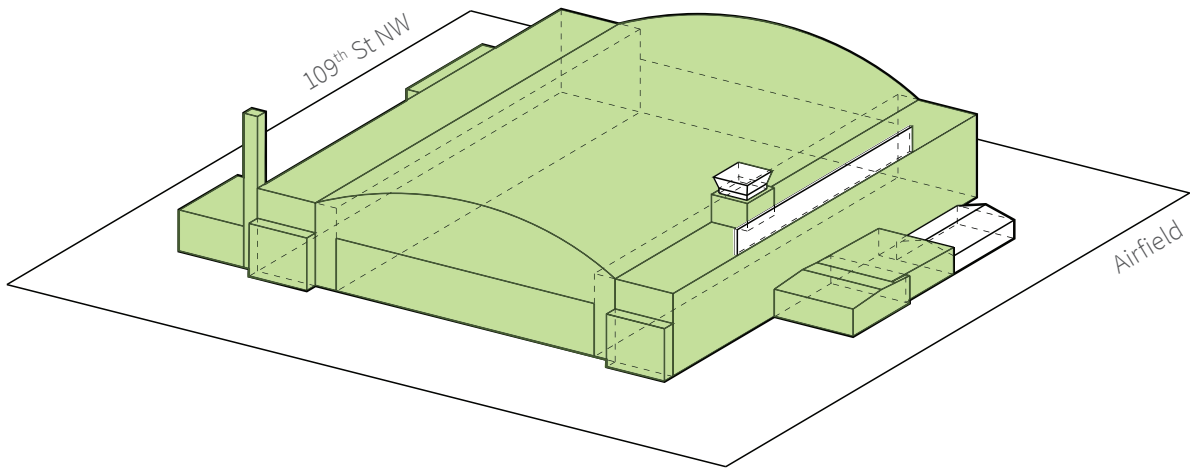

Northwestward View

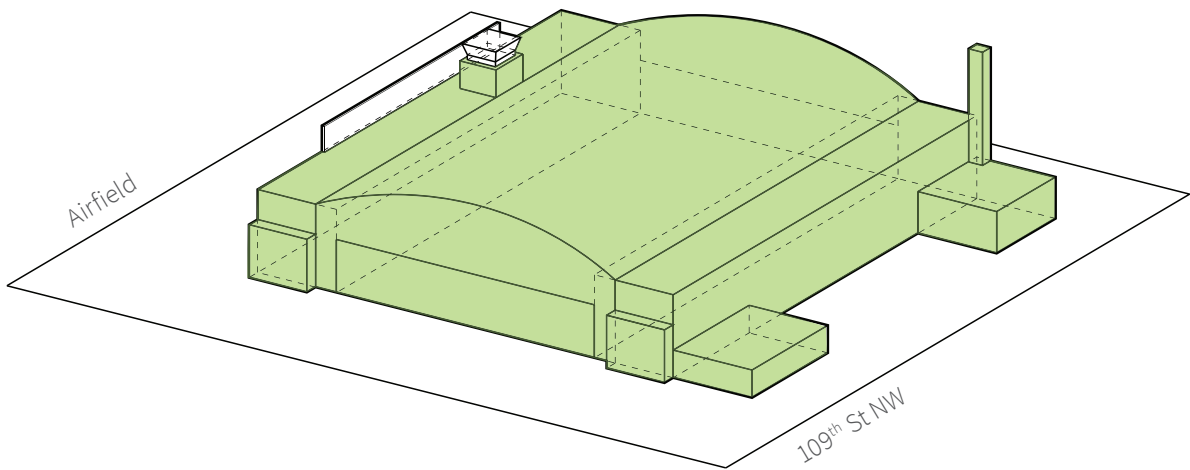

4 CULTURAL HERITAGE VALUE

4.1 Synthesis of Existing Evaluation of Significance and Integrity

Hangar 11 has previously been evaluated for historic significance and integrity under the framework and criteria provided by the Province of Alberta for the municipal evaluation of prospective historic resources.

It was evaluated most recently by David Murray Architect in conjunction with Next Architecture and Ken Tingley in the April 2017 *Heritage Assessment of Hangar 11*. The report concluded that Hangar 11 meets the Province of Alberta's significance criteria A, B, C, and E:

- A: Association with the Significant Themes of *Military, Business and Commerce, and Transportation*;
- B: Association with the Significant Institutions/Persons *Aircraft Repair/Northwest Industries, Leigh Brintnell and Francis G. Winspear*;
- C: Representation of the “*20th C. Functional Style*” of construction, and representation of the work of a master, Edmonton architect *George Heath MacDonald* and Edmonton contractor *H. S. MacDonald***; and,
- E: Symbolic value / role as a landmark.

The April 2017 report additionally found that Hangar 11 meets five of the Province of Alberta's integrity criteria (integrity of location, design, materials, workmanship, and feeling), but does not meet two criteria (integrity of environment and association).

Analysis

This report acknowledges that there are many ways to interpret evaluation criteria and to describe a site's merit under such criteria. Regardless of the way in which Hangar 11's significance and integrity is described, the Site does meet the threshold for significance to merit recognition on the Inventory and Register of Municipal Historic Resources.

This Historic Building Record has evaluated Hangar 11's significance and integrity under the Province of Alberta's criteria. The analysis synthesizes and incorporates content from the April 2017 *Heritage Assessment of Hangar 11*. Under this assessment, Hangar 11 meets all five of the criteria used to assess the significance of historic resources.

**Note: As discussed on pg. 18, it is not confirmed that the MacDonalds designed and built Hangar 11.

4.1.1 Analysis for Heritage Significance

Hangar 11's heritage significance is assessed using the Province of Alberta Historic Resources Management Branch's criteria for significance, which asks the following five questions:

A. Is Hangar 11 directly associated with a theme, activity, cultural practice or event that has made a significant contribution to the broad pattern of municipal history?

Hangar 11 is directly associated with the *establishment of an American detachment at Blatchford Field (an event)* to serve as a base for the Northwest Staging Route during World War Two. It is also associated with the *Northwest Staging Route as an aircraft transportation activity* that was carried out throughout the war years.

As noted in Section 2.6, Hangar 11 is associated with the *themes of:*

- *Aviation and Civic Identity: Edmonton as the "Gateway to the North";*
- *Canada and the War Effort: Infrastructure on the Home Front; and,*
- *Pioneer Commerce and Industry at Edmonton Municipal Airport.*

B. Is Hangar 11 directly associated with a significant institution or with the life of a significant person in the municipality's past?

Hangar 11 is directly associated with the *institution of Edmonton's Municipal Airport*. The airport opened in 1919-20, became Canada's first municipal airport in 1926, and operated for almost a century at Blatchford Field prior to its 2013 closure. Edmonton Municipal Airport was critical to commercial ventures in the city's early years, which helped to diversify its economy beyond agriculture. Its status as a major airfield led to the Edmonton's large-scale use by American forces during World War Two; their use of the city as a base (which ultimately boosted its economy long term) was largely driven by the fact that the airport was sufficiently established to service transportation routes.

Hangar 11 is also directly associated with the *institution of Northwest Industries Ltd.*, a pre-World War Two northwest service firm (Mackenzie Air Service) that adapted to serve war-era aircraft repair needs as Aircraft Repair Ltd., and ultimately became a major military contractor based out of Edmonton in the post-war years. Hangar 11 was used as the Commercial Air Service hangar for Northwest Industries beginning in the mid-1950s. Its involvement with Northwest Industries additionally connects the Site to prominent Albertans Leigh Brintnell (who established the firm) and Francis G. Winspear (its President and CEO in the 1950-60s).

C. Does Hangar 11 embody the distinctive characteristics of a type, style, period or method of construction, or represent the work of a master, or express high artistic values?

Hangar 11 embodies the *distinctive characteristics of the aircraft hangar building type*. It is particularly representative of pre-World War Two and wartime era hangars, with its arched (rather than flat) roof over its central open space.

The building is characterized by a large, central open space with an arched roof supported by wood bowstring trusses. The central open space is bordered by three storeys of office space, incorporating additional mechanical and functional uses including restrooms, with additional single-storey ancillary extensions (boiler room, loading bays, office space) on the east and west sides. The north and south elevations feature large sliding doors, the operating mechanism for which is built into the building and floors.

Hangar 11 is representative of a unique *method of construction in its use of wood bowstring trusses* in the roof structure.

D. Does Hangar 11 yield, or is it likely to yield, information important to the municipality's history, prehistory or natural history?

Hangar 11 *yields information that indicates that there was once a significant municipal airport located at Blatchford Field*. The airport itself carries significant heritage value as the first municipal airport in Canada, and for its international role as a training ground and military staging route base during the Second World War. The municipal airport's history is currently evidenced by the airfield layout on the larger site, including the existence of other hangar structures on the edges of the field, and the remnant control tower at its centre. With the impending reuse of the larger field area, however, Hangar 11 will serve a more critical role in conveying the Site's history as an airfield. Its clear appearance as a hangar building type will convey to passersby that there is a history of aviation in the vicinity.

E. Is Hangar 11 particularly prominent or conspicuous, and has it acquired special visual, sentimental or symbolic value that transcends its function? Does it contribute to the distinctive character of the municipality?

Hangar 11's appearance as a hangar building, a relatively uncommon building type in Edmonton, distinguishes it as a *local landmark*. It contributes to the distinctive character of the Blatchford area as a remnant industrial airfield zone.

4.1.2 Analysis for Integrity

Hangar 11 has been analyzed for integrity using the Province of Alberta Historic Resources Management Branch's seven integrity criteria:

- **Location** is the place where an historic resource was constructed or the site where an historic activity or event occurred;
- **Design** is the combination of elements that create the form, plan, space, structure and style of a resource;
- **Environment** is the physical setting of an historic resource. Whereas location refers to a specific place, environment refers to the character of the place in which a resource played its historic role;
- **Materials** are the physical elements that were combined or deposited during a particular period(s) or time frame and in a particular pattern or configuration to form an historic resource;
- **Workmanship** is the physical evidence of the crafts of a particular culture or people during any given period in history;
- **Feeling** is the resource's continued ability to convey the aesthetic or historic sense of a particular period of time; and,
- **Association** is the direct link between an historic resource and a significant historical theme, activity or event, or an institution or person.

ERA's analysis supports the conclusion in the April 2017 *Heritage Assessment of Hangar 11* that Hangar 11 retains integrity of location, design, materials, workmanship, and feeling, but has lost integrity of association, and will likely lose integrity of environment.

Hangar 11 has lost much of its integrity of association as it does not feature elements that explicitly demonstrate the building's historic relationship to the World War Two-era American detachment, the Northwest Staging Route, Northwest Industries Ltd, or the now-closed Edmonton Municipal Airport.

Hangar 11 will lose its integrity of environment with the redevelopment of the now-closed Edmonton Municipal Airport, to the point where it will no longer appear as an airport.

Despite these losses, ERA's analysis concludes that Hangar 11 retains sufficient integrity to convey the airfield activity that the building supported over eight decades. Heritage interpretation can also support the communication of this history as part of an adaptive reuse strategy for the building, which could re-establish some integrity of association.

4.2 Draft Statement of Significance

Description of Resource

Hangar 11 is an aircraft hangar constructed under the direction of the U.S. Army Air Force in 1942 at the former Edmonton Municipal Airport, at 11760 109th Street Northwest. The hangar is built of wood, and consists of a central open space covered by an arched roof, and three storeys of ancillary spaces on its east and west sides. Single-storey extensions flank both sides.

Heritage Value

Hangar 11 carries historical value for its association with Edmonton's role as a southern base for the Northwest Staging Route and other joint Canadian-American operations that transported materials north to Alaska during World War Two. Constructed as one of four hangars for the newly-established American detachment at Blatchford Field during 1942-43, Hangar 11 played a direct role in aircraft staging and movement along the Northwest Staging Route, which ran from Montana to Fairbanks, Alaska.

It supported the transfer of over 7,000 lend-lease aircraft from the United States to the U.S.S.R. for use against the Axis forces on the eastern front between 1943 and 1945. Its urgent construction for the U.S. Army Air Force in 1942, as part of a complex of over 50 buildings, employed readily available construction resources, resulting in a hangar built predominantly of wood rather than the steel which would have otherwise been used at the time.

Hangar 11 carries additional historical value for its association with the Edmonton Municipal Airport, otherwise known as Blatchford Field and, later, the Edmonton City Centre Airport. Blatchford Field was officially established in 1926 as Canada's first municipal airport. Its early years reflected a local engagement with aviation as a novel recreational activity. Edmonton's aviation pioneers used Blatchford Field as their base as they pursued commercial ventures delivering people and goods to isolated northern communities. Edmonton was recognized as a leader in the new industry of aviation, and activities at Blatchford Field expanded over the next several decades to accommodate municipal administrative services, commercial firms, industrial works, passenger routes and, for a period, wartime training facilities. Hangar 11 served military and commercial uses at the Edmonton Municipal Airport until its closure in 2013.

Hangar 11's historical value extends further with its association to Northwest Industries Ltd., an Edmonton-based aircraft manufacturing and repair firm active from the late 1930s to the 1990s. Northwest Industries Ltd. began as a branch of Wilfred Leigh Brintnell's Mackenzie Air Service, a Blatchford Field-based bush pilot firm that established an aircraft repair branch in 1936. The firm was reorganized as Aircraft Repair Ltd. the following year, and received military contracts to repair enlisted aircraft through the Second World War. In 1945, Aircraft Repair Ltd. was reorganized again as Northwest Industries Ltd., and continued to receive military contracts for aircraft manufacturing and modifications.

The Northwest Industries plant, located at Blatchford Field's north end, expanded into the former U.S. Army Air Force hangars at the airfield's east edge, including Hangar 11, in 1956. Thereafter, Northwest Industries expanded into related ventures like commercial air transport services under Albertan business mogul Francis G. Winspear. Hangar 11 hosted the firm's Commercial Air Service, among other uses, until Northwest Industries relocated to Edmonton International Airport in 1982.

Hangar 11 exhibits design value as a 1930s-40s hangar building, a rare building typology in Edmonton and in Alberta. Like earlier small- to medium-scale hangar buildings at Blatchford Field and elsewhere in North America, Hangar 11 is characterized by a central open airplane storage space with an arched roof, bordered by equally tall ancillary zones located on either side of the roof arch.

The building incorporates remnant features of the historic control tower on the building's west side, as well as single storey supplementary extensions, including a boiler room on the building's east side and loading bays on the west. Hangar 11 exhibits further design value through its wood bowstring roof trusses, which represent a unique method of construction in service of the building's rare arched roof form.

Hangar 11's distinct form has made it a valued local landmark in the Blatchford neighbourhood, representing the field's historic use as an airfield. Hangar 11 carries the potential to yield information that the site once served as the Edmonton Municipal Airport, Canada's first municipal airport, as one of the last remnants of the airport's built character and military history in a neighbourhood that is evolving.

Character-Defining Elements

Elements that convey Hangar 11's association with the World War Two-era American detachment in service of the Northwest Staging Route include:

- Siting on the west side of 109th Street Northwest, on the former site of the American detachment from 1942-1944;
- Original wood construction materials, including the structural frame, sheathing, trusses, remnant cladding, floors and fixtures;
- Original features or fixtures that convey the building's construction in the 1940s, including original windows and visible antique mechanical works;
- Remnant features, fixtures or signage that may explicitly convey the building's construction for the U.S. Army Air Force.

Elements that convey Hangar 11's association with Northwest Industries Ltd. include:

- Remnant Northwest Industries signage that may remain on the building's exterior or interior;

Elements that convey Hangar 11's association with the Edmonton Municipal Airport, its potential to yield information about the Edmonton Municipal Airport, and its status as a local landmark include:

- Location on the former Blatchford Field, or the Edmonton Municipal Airport.

Elements that convey Hangar 11's design as a 1930s-40s hangar building include:

- Form, scale and massing conveying the appearance of a 1930s-40s hangar building;
- Original door and window openings;
- Tall, rolling access doors on both the north and south elevations, including steel roller wheels and embedded steel tracks in the

concrete floor, wood tracks embedded in the ceiling, wood drainage grilles and rolling door hardware;

- The base of the former control tower, projecting as an overrun above the west office wing;
- Large, open-concept central main hall, including:
 - Form and scale of the main hall;
 - Arched main hall roof supported by massive wood bowstring trusses and timber columns with diagonal bracing;
 - Concrete flooring in the main hall; and,
 - Expression of piers in the east and west walls.
- Configuration of the office wings on the east and west sides of the central main hall, including:
 - 1940s office features, original wood-panel office doors with wood trims, and original single-hung wood windows and window openings overlooking the main hall from the office wings.
- Freight elevator in the west office wing, including its counter-balanced, upward-sliding slatted wood gates; and,
- Flat open space at the north and south sides of the building where aircraft historically entered and exited the building.

5 HERITAGE POLICY REVIEW

5.1 Standards and Guidelines for the Conservation of Historic Places in Canada

The Standards and Guidelines for the Conservation of Historic Places in Canada (“the Standards and Guidelines”) is produced by Parks Canada and serves as the Canadian government’s guiding document on the treatment of historic places across the country.

It was adopted by the Province of Alberta as a guiding heritage document in 2003, and the City of Edmonton’s Historic Resource Management Plan’s Heritage Policy #6 directs that the City’s “Historic Resource Management Program will be aligned with the Standards and Guidelines for the Conservation of Historic Places in Canada.”

The Standards and Guidelines describes three types of intervention for historic places (Preservation, Rehabilitation and Restoration), and describes the situations in which each is considered appropriate. The document then lays out general Standards for conservation work, and more specific Standards associated with each of the three types of interventions. It assists in interpreting the Standards by providing Guidelines for various types of work on historic places, offering both recommended strategies and strategies that should be avoided.

The Standards and Guidelines prescribes a three-step conservation decision-making process:

1. Determine the primary treatment;
2. Review the Standards; and,
3. Follow the Guidelines.

Rehabilitation as the Primary Treatment

Hangar 11 will no longer be used as an airplane hangar building, as the Edmonton City Centre Airport has been closed. If it is to be conserved, it will ultimately be adapted to be reused for a different program.

Under the Standards and Guidelines, Rehabilitation is considered the most appropriate intervention in instances involving a change to a new use. Rehabilitation is defined as follows: “the action or process of making possible a continuing or compatible contemporary use of an historic place, or an individual component, while protecting its heritage value” (pg. 17).

The Standards and Guidelines elaborate further:

Rehabilitation involves the sensitive adaptation of an historic place or individual component for a continuing or compatible contemporary use, while protecting its heritage value.

Consider Rehabilitation as the primary treatment when:

- (a) Repair or replacement of deteriorated features is necessary;
- (b) Alterations or additions to the historic place are planning for a new or continued use; and,
- (c) Depiction during a particular period in its history is not appropriate” (pg. 16).

Reviewing the Standards

All nine of the General Standards apply to Rehabilitation projects, as do Standards 10, 11 and 12, which are specific to Rehabilitation projects. The Standards that are most relevant to this project centre around three concepts:

- The conservation of character-defining elements, even throughout a conversion to a new use. Character-defining elements are to be maintained wherever possible, repaired where necessary, and replaced in kind (where evidence permits) only where they are so lost or deteriorated that there is no ability to repair;
- An aim toward minimal intervention, i.e. only the intervention that is necessary to accommodate contemporary safety, accessibility, programmatic and other requirements; and,
- Contemporary interventions must be compatible with, distinguishable from and subordinate to the original resource, and they must be as reversible as possible.

Following the Guidelines

The relevant Guideline sections should be consulted with respect to the specific elements of the proposed work.

Conservation of Character-Defining Elements in Rehabilitation Projects

The Standards and Guidelines offers specific guidance on the replacement of Character-Defining Elements, which may be required throughout a Rehabilitation project involving conversion to a new use:

Replacement of all or parts of character-defining elements should only be considered when repair is not possible, and if there is sufficient physical evidence to match the forms, materials and detailing of a sound version of the same element. Replacement may be required because an existing feature is so severely deteriorated or damaged that repair is not possible, or because a feature is missing entirely. In all cases where replacement is required, sound elements that may be part of a larger grouping should be preserved. For example, a few brackets in a cornice, a few windows in a factory or a few plantings in a flowerbed may be salvageable, even though the overall character-defining element is severely damaged.

It is particularly important to understand the distinction between replacement as part of rehabilitation or restoration, as described in Standards 10 and 13.

Replacement as Part of Rehabilitation

In a Rehabilitation project, replacing a character-defining feature that is beyond reasonable repair may be appropriate if its essential form and detailing are still evident. Replacing a feature that is missing, but known from physical, documentary and oral evidence, may be appropriate; however, accepting the loss and not intervening is another possibility. (Where an important feature is missing, its replacement is always recommended in these Guidelines as the preferred course of action.) The approach for replacement work will depend on the overall design approach and design intentions, and most particularly, on achieving a visual and functional balance between the new work and the historic place. In some cases, the preferred design approach will be replacement in kind; in other cases, substitute forms, materials or detailing may be appropriate. In both situations, the replacement should be visually and physically compatible with, and distinguishable from, the historic place. If the replacement is in kind, the work need only be distinguishable on close inspection. (Standards and Guidelines for the Conservation of Historic Places in Canada, pg. 43)

5.2 The Way We Grow: Municipal Development Plan (2010)

Edmonton's 2010 Municipal Development Plan (The Way We Grow) provides for much stronger heritage protections than those in the previous Municipal Development Plan (Plan Edmonton).

The Way We Grow's stated heritage objective is found in Section 5.8.

5.8.1 Encourage a sense of local identity and create connections to the city's cultural and historical roots through the conservation and preservation of significant buildings, districts, landscapes and archaeological resources.

The Way We Grow outlines nine heritage policies to support this objective. Those relevant to Hangar 11's conservation and future use are listed below:

5.8.1.1 Integrate heritage conservation into the broader context of planning and decision making.

5.8.1.2 Ensure new development adjacent to properties on the Register and Inventory of Historic Resources in Edmonton respects the scale, massing, proportions and character of existing buildings.

5.8.1.3 Support conservation and adaptive reuse of historic resources through creative design solutions and incentives;

5.8.1.4 Ensure all City-owned historic resources are conserved and maintained in a good state of repair;

5.3 Historic Resources Management Plan (2009) and Policy C450B

The City of Edmonton Policy C450B ("Policy C450B") is intended to guide the City of Edmonton in decision-making processes around the identification, conservation and promotion of historic resources. The City of Edmonton Historic Resources Management Plan complements Policy C450B by clarifying and building on its policy directions.

The Historic Resources Management Plan outlines 24 heritage policies to guide the City of Edmonton's heritage program. Those relevant to Hangar 11's conservation and future use are listed below:

Heritage Policy #3: Historic Interiors

The City will consider historic interiors as part of the assessment of historic resources at the register and inventory stages.

- 3.2 Explore methods to encourage historic resources to be occasionally opened to visitors so that interior elements can be viewed and enjoyed by the public.

Heritage Policy #6: Standards

The Historic Resources Management Program will be aligned with Standards and Guidelines for the Conservation of Historic Places in Canada.

Heritage Policy #8: Variety of Incentives

The City will endeavor to provide a variety of incentives to assist with the preservation and adaptive reuse of historic resources.

- 8.7 The City should identify resources to enable the purchase, restoration and sale of historic resources for the specific purpose of saving the building.

Heritage Policy #11: Stewardship of City Historic Resources

The City will encourage the retention, restoration and designation of all of its own historic resources and advocate for its ad-hoc bodies, autonomous agencies and other public bodies to do the same.

Heritage Policy #14: Development Policies and Guidelines

The City will develop policies, regulations or guidelines to ensure that historic resources and their immediate surroundings are included in the development process.

- 14.2 Develop regulations, guidelines or processes to ensure that development in areas surrounding historic resources respects the heritage value of the historic resource.
- 14.4 Develop design regulations for identified historic areas to ensure infill development is sensitive and in character.
- 14.5 Develop partnerships with other programs and agencies to allow historic resources to accommodate new technology or modern standards, e.g. insulation, windows.

5.4 City Centre Area Redevelopment Plan (2012)

The City Centre Area Redevelopment Plan (ARP) provides objectives, policy direction and a master plan concept what will be known as the Blatchford neighbourhood, on the former Edmonton Municipal Airport lands.

The ARP provides seven master plan principles for the lands, the seventh of which speaks to the conservation of the former airport's history:

- 6.2.7 There is a rich history attached to the Plan area and this must be embodied through each stage of the plan-making process that includes preservation, naming, interpretation, and designation. The repurposing of the hangars as recreational or other community facilities is an objective of this ARP.

In Section 7.1, objectives are provided for the Town Centre District, in which both Hangar 11 and Hangar 14 are located. Objective 7.1.6 provides the following policy direction:

- 7.1.6 Repurpose existing hangars for recreational, cultural or other community facilities to recognize the significant historical role of the Plan area, where appropriate.

6 ASSESSMENT OF EXISTING CONDITION

6.1 Overview

The Historic Building Condition Assessment for Hangar 11 was conducted to determine the building's existing condition via a non-destructive interior and exterior visual inspection.

The building has total floor space of approximately 6,860 m² (73,840 sq. ft.). Its central airplane hangar space is roughly 46 m wide x 64 m long and its two 3-storey ancillary office banks are approximately 9 m wide x 64 m long.

The loading bays at the west side are approximately 203 m². The single storey ancillary space at the building's southeast corner is approximately 171 m². The boiler room at the northeast corner is 93m².

The hangar rests on a concrete slab-on-grade foundation, and the main hangar space is framed with built-up laminated beam and bowstring timber trusses on wood columns. The ancillary office banks and other areas appear to be wood-frame post-and-beam construction with concrete slab-on-grade.

The exterior is clad with horizontal metal siding. The glazing system consists of double pane glazing in wood and metal frames, and runs three storeys along the east and west faces of the ancillary wings, wrapping to the north and south faces on the third floor. The north and south faces of the hangar are equipped with large rolling wooden doors on a track system, with the bottom rail embedded within the concrete floor and the top rail connected to the underside of the roof structure above. The roof consists of a built-up membrane system with gravel ballast on flat areas. The building has been vacant since 2013.

ERA Architects Inc. undertook a preliminary site investigation on April 10th, 2019, in sunny weather with temperatures around 11°C. No destructive testing was administered, and all exterior investigations were taken from ground level; roofs were not accessed due to safety concerns, but this report was informed by 2017 drone footage used to determine roof condition.

An in-depth assessment of existing structural, substructural, conveying, plumbing, HVAC, fire protection and electrical systems is not included in the scope of this report, but has been addressed in the 2017 Condition Assessment report produced by S2 Architecture. An updated structural assessment has also been prepared by RJC (see Appendix E), which should be read in conjunction with this report.

The building components were graded using the following assessment system:

Excellent: Superior aging performance. Functioning as intended; no deterioration observed.

Good: Normal Result. Functioning as intended; normal deterioration observed; no maintenance anticipated with in the next five years.

Fair: Functioning as intended; normal deterioration and minor distress observed; maintenance will be required with in the next five years to maintain functionality.

Poor: Not functioning as intended; significant deterioration and distress observed; maintenance and some repair required with in the next year to restore functionality.

Defective: Not functioning as intended; significant deterioration and major distress observed.

Throughout the Condition Assessment in Sections 6.3-6.4, Hangar 11's central open space is referenced as "the hangar", in contrast to the east and west office wings and other ancillary spaces.

Hangar 11 Condition: Overview

The existing building shell and supporting structure, comprising the principal character-defining aspects of the heritage resource, appear to be in fair condition with a high potential for restoration, salvage and reuse. The timber post and beam structural frame, as well as the curved wood bowstring trusses in the central hangar space, exhibit little visible surface degradation and should be considered important features worthy of conservation.

Existing non-structural cladding and finish systems are generally in poor condition with many aspects in a fair state of repair, however there are a number of deficiencies and deteriorated conditions that are the result of deferred maintenance, vandalism and overall building neglect.

There are significant systems and components inside the building that are degraded, deteriorated and damaged to the point where occupancy is not advisable and/or possible due to health/life safety, code compliance and imminent breakdown. Major systems to support occupancy are either not present or only partially remaining. There are also significant breaches to the building envelope that require immediate attention, several of which are causing significant deterioration of the roof and floor framing in the west ancillary wing. All of these deficiencies require significant overhaul in order to stabilize the heritage resource for its future conservation and reuse.

6.2 Building Modifications

Hangar 11 has undergone a number of renovations and alterations over its history. It was constructed in 1942, and the single-storey loading bays on the building's west side were added in the late 1940s. The hangar's control tower, installed above what appears to be the freight-elevator overrun in the late 1940s, has since been dismantled. The building's original exterior siding is unknown, and was replaced with white-finished metal siding at a later date.

Original door and window openings remain intact but most exterior doors and windows are not original. The exterior windows are estimated to have been replaced in 1977. One rolling door in the south elevation appears to have been replaced with a contemporary garage-style door.

There is evidence of previous repairs, renovations and alterations carried out on the property, including to the layout and flooring in some areas of the office wings, and to the lighting in the main hangar space. However, formal records of maintenance procedures and logs were not available to review in the preparation of this report. Previous building condition reports dating to June 2015 and June 2017 have informed the analysis conducted below.

6.3 Existing Condition: Exterior Envelope

6.3.1 Roof Systems

According to the previous building envelope condition assessment by S2 Architecture (2017), the existing roof system above the hangar trusses is comprised of:

- suspended ceiling panels;
- timber frame bowstring trusses;
- wood board deck;
- protection board (assumed); and,
- SBS roof membrane.

The existing flat roof system consists of:

- vapour retarder;
- batt insulation;
- 2x 10 wood ceiling joists @ 12”;
- T&G wood board deck;
- protection board (assumed);
- built-up roof membrane; and
- a ballast layer.

Inspecting the roof structure from below, the roofing system appears to be in very poor to defective condition. The age of the roofing system is unknown, but appears to be past its acceptable service life. Major leaks were noted in the west ancillary wing, visible from the interior.

The majority of the flat roof leaks, several of which were active at the time of review, appear to be concentrated toward the centre of the west wing, moving northward.

As noted in the 2017 assessment, several breaches in the ceiling were observed, with saturated batt insulation and ponding water and mould present behind the polyethylene vapour retarder (Figures 1-5).

There is vegetation that is actively growing, in moss form, in several of the carpeted rooms (Figures 6 & 7).

Active leaks were additionally observed in the central open space at both the east and west ends, suggesting failure of the roofing

membrane, flashings and tie-ins where the two adjoining flat roofs meet the central hangar roof (Figures 8-14).

Ponding, as well as ice patches, were noted in several locations on the slab in the central open space (Figures 15 & 16). Black fungal growth was observed on the ceiling panels and walls, which is an indicator of prolonged high moisture levels.

The low flat roofs of the east and west additions were partially observed from adjacent upper floors (Figures 17 & 18). These roofs appear to be in fair to poor condition, with several uneven surfaces causing differential drying-out patterns, particularly on the northeast corner roof where patches of vegetation were also seen along the perimeter.

Roof System Recommendations

- Full replacement of the roofing system, carried out from an operating budget until further decision is made regarding the future adaptive reuse and conservation of the building (see Section 7.2.2 - SP-03 and SP-04).
- Replacement of all flashings and tie-ins, including flashing at all stacks and roof penetrations. Roof drains are of contemporary design and should be replaced (see Section 7.2.2 - SP-04).
- Install insulated roofing assembly from the exterior side of the hangar, so as allow for the exposure of the wood trusses from the interior.

Roof System Photographs



Fig. 1



Fig. 2



Fig. 3



Fig. 4



Fig. 5



Fig. 6



Fig. 7



Fig. 8



Fig. 9



Fig. 10



Fig. 11



Fig. 12



Fig. 13



Fig. 14.



Fig. 15



Fig. 16



Fig. 17



Fig. 18

6.3.2 Floor and Roof Structure

It was not possible to undertake a comprehensive review of the floor and roof structure. However, there is clear indication of water ingress from below in multiple locations, most notably the west ancillary wing and at tie-ins to the central open space roof.

Visible black staining of the ceiling and floor joists, decking and cross-bridging was observed in several of the rooms where ceiling finishes have collapsed, suggesting potential subsurface degradation of the wood elements (Figures 19 & 20).

Assessment of the bowstring trusses in the main hangar space could not be undertaken, apart from limited visual access from access hatches on the third floor (Figures 21-26).

The review did not reveal any visual evidence of major deterioration of the wood members, however some water staining was present and several small openings in the decking were observable as daylight could be seen passing through the boards.

Several of the truss ends were exposed in the office wings through the interior walls and were found to be generally close to saturation, the ends physically damp to the touch and resulting in visible wood decay (Figures 27 & 28) as were several posts in the hangar space (Figures 29 & 30). It is highly probable that the majority of wood members have moisture content well above equilibrium levels for the material.

Structural Review

In order to better understand the current condition of the existing structure, RJC Engineers has conducted further testing and analysis to assess the condition of the wood primary members and the building's foundation system.

The primary purpose of this work is to identify measures that need to be taken to stabilize the existing building structure. It is additionally intended to identify minimum requirements for the restoration of the building to allow occupancy to suit a future use.

RJC's work involves the following key aspects:

- An on-site visual review of the present facility to establish / verify any marked changes in the building's condition relative to the 2017 report.

- Non-destructive testing to assess the extent of biodegradation of the columns and roof trusses in the main hangar space; as well as the columns, floor and roof joists in the ancillary wings. As safety hazards may limit the extent of this investigation, extrapolation regarding the general condition of these elements may be required.
- A general assessment on current structure's ability to resist seismic forces should the COE determine that this facility must satisfy seismic loading as determined by the current Alberta Building Code.
- A review of anticipated roof design loads at the time this facility was designed and compared against current code designated snow loads. RJC could not carry out a detailed analysis of roof members/trusses to establish load capacities as the attic spaces were not safe for access at the time of the review.
- General commentary on the existing structure's ability to support roof snow loading for both the main hangar and the ancillary spaces, as well as intermediate floor loading capacities for the East and West ancillary spaces in accordance with the current Alberta Building Code.
- Excavation & exposure of selected building foundation locations, so as to observe the foundation's current condition and to check against any unexpected deterioration. It is proposed that this excavation occurs on the building's exterior perimeter, at two locations.
- A structural report and a separate Class D cost estimate for the recommended scope of work (see Appendix E).

It should be noted that the results of this structural review will bear on the Stabilization and Conservation Scopes (and the associated costing). This is outlined in Section 7 of this report.

Floor and Roof Structure Recommendations

- Provide temporary bracing as required adjacent to any interior floor areas exhibiting signs of distress, such as sagging, deflection or excessive water saturation. Remove the existing deteriorated sections of floor and reframe with new infill floor structure (see Section 7.2.2 - SP-02).
- Where found to be in a state of disrepair, existing wood members should be examined with a view to conservation, even in part, using moisture-expelling epoxy consolidants (see Section 7.2.3 - CP-01).
- Remove existing deteriorated sections of floor on the west ancillary wing and infill with new wood floor structure (see Section 7.2.3 - CP-08).
- See Appendix E for additional structural recommendations by RJC.

Floor and Roof Structure Photographs



Fig.19



Fig. 20



Fig. 21



Fig. 22



Fig. 23



Fig. 24



Fig.25



Fig. 26



Fig. 27



Fig. 28



Fig. 29



Fig. 30

6.3.3 Exterior Walls

According to the previous building envelope review included in the condition assessment report by S2 Architecture (2017), the existing exterior wall assembly is comprised of:

- vapour retarder;
- batt insulation;
- wood-framed stud wall;
- T&G wood board sheathing;
- building paper;
- fibre board; and,
- metal siding.

The exterior of the building is clad in prefinished white steel siding, arranged in a horizontal shiplap configuration with green painted galvanized steel flashings at the coping. Flashings are generally found to be uneven and discontinuous, with signs of corrosion visible where the outer paint layer has worn away (Figures 31 & 32). There is no evidence of any remaining original wood siding.

Some areas of flashing were missing entirely, such as at wall corners and roof junctions (Figure 33). Rust staining was observed in some of the corners, where flashings have failed (Figures 33 & 34). Large sections of siding were found to be missing or separating from the sheathing on the west and south elevations, exposing the interstitial layers of the assembly (Figures 35-37).

Smaller sections of siding were observed to be missing on all four sides of the building, with visible discontinuities in the air barrier system (Figures 38-41). Deterioration of the pine sheathing boards was noted at several locations where corner junctions are exposed (Figures 42 & 43) and it is likely that similar degradation of the wood is occurring beneath the surface where the exterior envelope is compromised.

Exterior Wall Recommendations

- Full replacement of the exterior cladding and air barrier system (see Section 7.2.3 - CP-17).
- Replacement of all flashings and transition membranes, including flashings at wall openings (see Section 7.2.2 - SP-15; Section 7.2.3 - CP-17).

- Provide insulation outboard of sheathing to reduce thermal bridging to the interior, with additional spray-foam insulation on the interior side to improve R-values and air-tightness of envelope (see Section 7.2.3 - CP-17).

Exterior Wall Photographs



Fig. 31



Fig. 32



Fig. 33



Fig. 34



Fig. 35



Fig. 36



Fig. 37



Fig. 38



Fig. 39



Fig. 40



Fig. 41



Fig. 42



Fig. 43

6.3.4 Windows

The condition of the existing windows was visually reviewed from the interior spaces, as well as externally from ground level. Contemporary double-glazed aluminium windows and interior storms have been installed at the exterior of the building and appear to be in generally fair condition (Figures 44-49).

As noted earlier in this report, the original exterior windows have been replaced and the current ones likely date from 1977, as per the manufacturer's etched inscription on the spacer bars (Figure 50). Several units were found to have broken glass and/or damaged screens (Figures 51-53), and condensation was observed on the glazing on the third floor of the east and west wings (Figure 54).

Perimeter sealant joints appear to be in poor condition overall, and are exhibiting age-related distress in the form of adhesion failure, cracking and debonding (Figures 55 & 56). Several of the join sealants were found to contain asbestos. Some of the frames contain flaking/peeling paint and visible signs of deterioration between the panes (Figures 57-60).

Interior wood windows were studied on east and west walls facing the interior of the hangar space. They are single hung, one-over-one sash type, with single clear glass panes, and appear to be original to the building (Figures 61-63).

The glazing and flat frames appear to be in fair condition, with limited wear including the putty securing the glass panes in place. Paint finishes are generally sound, and appear to have been reapplied as part of previous work.

Some areas show uneven paint build-up, suggesting the frames were locally touched up rather than fully repainted (Figure 64). No signs of visible wood decay were observed, however some minor consolidation of the wood should be expected once the paint layers have been stripped and the bare wood exposed, particularly in areas where active roof leaks are occurring directly above.

Window Recommendations

- Repair and restore interior wood windows by repairing wood decay, repainting exposed surfaces on both sides, and replacing perimeter putty and sealant around window frames. Replace windows to match where required (see Section 7.2.3 - CP-11).

- Install wood storm windows on the office sides of the interior wood windows to improve thermal efficiency and reduce condensation (see Section 7.2.3 - CP-12). As an alternative to storm windows, single glazed units could be replaced with double-glazed inserts to match the appearance of the existing windows.
- Replace perimeter sealant on exterior windows (see Section 7.2.3 - CP-11).
- Replace contemporary aluminium windows with new metal-clad wood windows to match the building's original appearance (see Section 7.2.3 - CP-13).

Window Photographs



Fig.44



Fig. 45



Fig.46



Fig. 47



Fig. 48



Fig. 49



Fig. 50



Fig. 51



Fig. 52



Fig. 53



Fig. 54



Fig. 55



Fig. 56



Fig. 57



Fig. 58



Fig. 59



Fig. 60



Fig. 61



Fig. 62



Fig. 63



Fig. 64

6.3.5 Doors

Exterior doors were visually reviewed from both sides generally, however in the majority of cases the outer face had been boarded up with plywood and was not accessible (Figures 65-69).

The exterior doors are typically of a combination of solid wood panel and plywood construction, with knob-type locksets at man doors and makeshift push bars at exit doors (Figures 70 & 71). It is uncertain whether they are insulated.

Nearly all the exterior doors were non-operational at the time of review, thus door/hardware functionality and the presence/condition of weather stripping could not be observed apart from limited visual access. Rubber seal gaskets were noted at the jambs and headers of the southeast entrance door, however no bottom seal was apparent in this location, as a significant amount of daylight penetration could be seen at the threshold (Figure 72).

The north man door, which presently serves as the primary access to the hangar space, is of wood frame and plywood construction, with mechanically fastened sheet steel cladding that is consistent with the appearance of the rolling hangar doors (Figure 73). The door itself is in poor condition, with delamination of the sheet steel at the edges revealing visible degradation of the underlying wood. This condition is typical of the hangar doors, where wood edges are exposed to view and deterioration observable (Figures 74-79).

The painted sheet cladding on both the north and south main doors is heavily worn and corroding at the edges, surficial wear marks and fasteners (Figures 80 & 81), with some sections missing or damaged at the south facing doors (Figures 82 & 83). Above the cladding, the upper door sections are arranged in a three-over-three plywood panel layout with flat trim pieces at the panel joints (Figure 84). The plywood here is also in poor condition, with flaking and blistering paint revealing sections of deteriorated plywood, most likely the result of prolonged moisture trapping beneath the paint surface (Figures 85 & 86).

From the interior side of the hangar doors, cut-outs in the cladding provided a limited view of the inner wood-laminated structural frame and steel rollers (Figure 87). From what could be directly observed at the cut-outs, framing appears to be in fair to poor condition with signs of wear and some cracking and checking of the wood in evidence

(Figure 88). Loose bits of batt insulation were also present, suggesting that the doors are insulated (Figure 89).

Door tracks are ceiling mounted and constructed in wood, with bottom wood tracks and steel runners embedded in the floor (Figures 90 & 91). Tracks are generally still intact, though the present functionality of the roller system is not certain. The floor-embedded tracks were wet and punky to the touch and likely compromised.

The interior doors are typically of solid wood panel construction, with similar knob-type locksets and glazed lites in the offices (Figures 92-96). Overall, they are in good condition with limited wear and only local damage to frames, panels and glazing (Figure 97).

Door Recommendations

- Replace all exterior entrance doors with new commercial grade insulated metal doors (see Section 7.2.3 - CP-14).
- Hangar Doors Option 1: Rebuild hangar doors with new steel or glue-laminated timber frame, insulate with spray foam, provide new sheet metal cladding over pressure-treated plywood substrate to match original appearance, provide new automated steel track system and rollers (see Section 7.2.3 - CP-19);
- Hangar Doors Option 2: Strip down existing hangar doors to bare timber frame, re-insulate with spray foam, provide new sheet metal cladding over pressure-treated plywood substrate to match original appearance, provide new automated track system and rollers;
- Hangar Doors Option 3: Partially refurbish hangar doors to prevent further deterioration. Reinstall and fix in place as a non-functional historic artefact. Enclose hangar door openings with new contemporary glazing system;
- Retain, or salvage and reuse, interior wood panel doors. Strip doors to bare wood surface and repaint. (see Section 7.2.3 - CP-29).

Door Photographs



Fig. 65



Fig. 66



Fig. 67



Fig. 68



Fig. 69



Fig. 70



Fig. 71



Fig. 72



Fig. 73



Fig. 74



Fig. 75



Fig. 76



Fig. 77



Fig. 78



Fig. 79



Fig. 80



Fig 81



Fig. 82



Fig. 83



Fig. 84



Fig. 85



Fig. 86



Fig. 87



Fig. 88



Fig. 89



Fig. 90



Fig. 91



Fig. 92



Fig. 93



Fig. 94



Fig. 95



Fig. 96



Fig. 97

6.4 Existing Condition: Interiors

6.4.1 Interior Finishes

Interior wall, floor and ceiling finishes are heavily damaged overall as a result of deterioration from water damage, unconditioned environmental impacts (freeze/thaw), deferred maintenance and general building neglect. Apart from the wood swing doors, casings, and frame structure, much of the existing interior fabric is beyond repair, showing signs of physical distress from moisture damage as well as a high probability of contamination from mould and fungal spores (Figures 98 - 103).

The worst conditions were found on the west ancillary wing, where portions of ceilings have broken free and collapsed and floor finishes are heavily damaged (Figures 104 - 109).

Wall and ceiling finishes in the central hangar space are also generally defective from excessive wetting, fungal contamination and moisture damage primarily on the east and west sides (Figures 111 - 120).

Floor finishes are generally in fair to good condition on the east ancillary wing, as well as the southern part of the west wing (second floor), with some areas exhibiting local water damage, staining and missing/damaged floor boards (Figures 121 - 132).

Interior Finish Recommendations

- Remove water saturated batt insulation, vapour barrier & finishes at underside of flat roofs, exterior walls and west wing, down to bare floor deck (see Section 7.2.2 - SP-05, SP-06, SP-07)
- Abate and dispose of all remaining non-structural interior partitions, drop ceilings, deteriorated floor and wall finishes in ancillary wings, and remove all redundant building services (see Section 7.2.3 - CP-07);
- Abate and dispose of ceiling panels in hangar (see Section 7.2.3 - CP-15);
- Full replacement of interior floor, ceiling and wall finishes, non-original millwork and equipment (see Section 7.2.3 - CP-16).
- Refurbish wood flooring in east ancillary wing, as well as south half of second floor in west wing; locally replace missing or damaged floor boards as needed (see Section 7.2.3 - CP-24)

- Strip existing paint from interior hangar walls, replace deteriorated wall panels with matching plywood panels, paint 1 coat primer, 2 coats acrylic latex enamel (see Section 7.2.3 - CP-10);
- Refurbish wood flooring in east ancillary wing, as well as south half of second floor in west wing; locally replace missing floor boards as needed (see Section 7.2.3 - CP-10).

Interior Finish Photographs



Fig. 98



Fig. 99



Fig.100



Fig. 101



Fig. 102



Fig. 103



Fig. 104



Fig. 105



Fig. 106



Fig. 107



Fig. 108



Fig. 109



Fig. 110



Fig. 111



Fig. 112



Fig. 113



Fig. 114



Fig. 115



Fig. 116



Fig. 117



Fig. 118



Fig. 119



Fig. 120



Fig. 121



Fig. 122



Fig. 123



Fig. 124



Fig. 125



Fig 126



Fig. 127



Fig 128



Fig. 129



Fig. 130



Fig. 131



Fig. 132

6.4.2 Hangar Floor

The concrete floor slab in the hangar space was found to be in good condition generally, with limited cracking and other signs of movement (Figures 133-136).

Large sections of the floor were actively damp (Figures 137 & 138), with local ice patches and water ponding where active roof leaks have formed on the east and west sides (Figure 139).

Laminated wood floor embeds were thoroughly saturated on the north, east and west sides (Figures 140-143), presumed to be a result of general damp conditions inside the hangar.

Sections of wood floor immediately adjacent to the hangar slab were also found to be saturated (Figures 144-145)

Hangar Floor Recommendations

- Remove laminated wood embeds from ground floor concrete slab. Either replace in kind with pressure-treated wood, or patch with concrete and make good surfaces (see Section 7.2.3 - CP-20).
- Patch saturated areas of plywood subfloor with new pressure-treated plywood (see Section 7.2.3 - CP-21).
- Remove embedded wood trench drain and replace with new industrial steel trench drain cover plate to match (see Section 7.2.3 - CP-22).
- Provide local patch repairs to concrete floor where cracking or surficial damage has occurred (see Section 7.2.3 - CP-24).
- Clean existing floor slab, lightly polish and seal w/ clear penetrant (see Section 7.2.3 - CP-05).

Hangar Floor Photographs



Fig. 133



Fig. 134



Fig. 135



Fig. 136



Fig. 137



Fig. 138



Fig. 139



Fig. 140



Fig. 141



Fig 142



Fig. 143



Fig 144



Fig. 145

6.4.3 Freight Elevator

The freight elevator is located on the west ancillary wing and was visually reviewed at ground level (Figure 146). The inner cab walls, floor, doors and closing gate are built in wood frame construction, with the cab interior lined in painted sheet steel.

While the present functionality of the freight elevator could not be ascertained at the time of review, its future reuse under current building codes is highly unlikely.

Freight Elevator Recommendations

- Option 1: Replace existing freight elevator with functioning elevator system (see Section 7.2.3 - CP-04).
- Option 2: Refurbish cab walls, floor doors and closing gate, and reinstate as a non-functional historic artefact (see Section 7.2.3 - CP-04).

Freight Elevator Photographs



Fig. 146

6.5 Existing Condition: Ancillary Structures

6.5.1 Brick Chimney

The solid brick chimney stack, located at the northeast corner of the building, is an original feature and previously served the boiler plant. Inspection of the chimney structure, which stands approximately +14m high, took place from ground level.

Flues, flue connections or chimney interiors were not reviewed. There is evidence of minor localized spalling of the brickwork towards the top portion of the chimney on the south face, as well as deteriorated mortar joints on all four sides (Figures 147 & 148).

Roughly ten bricks have dislodged and are missing from the top of the west face, with further header bricks in a similarly loosened condition above the hole (Figure 149).

The precast capstone has undergone excessive weathering and remains in defective condition.

Brick Chimney Recommendations

- Strip the existing paint layer from the brickwork; rebuild loose, missing or damaged brick areas; 100% repoint mortar. Replace deteriorated capstone with new precast to match original size and profile (see Section 7.2.3 - CP-02);
- Provide all new base flashings for chimney stack (see Section 7.2.3 - CP-05);

Brick Chimney Photographs



Fig. 147

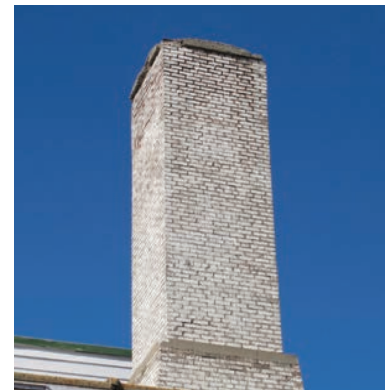

Fig. 148

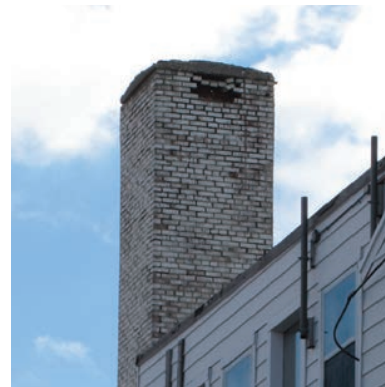

Fig. 149

6.5.2 Fire Escapes

The exterior wood fire escapes are currently located at all four corners of the property and are currently accessed from all upper floors of the ancillary wings. They are presently in a defective state, with significant portions showing signs of structural distress and material loss/decay, posing a high safety and security risk to the property (Figures 150 - 153).

Fire Escape Recommendations

- Option 1 (rebuild): Abate and dispose of existing exterior wooden staircases and ladders and rebuild (4) existing exterior wooden staircases and (3) existing exterior wooden ladders to match (see Section 7.2.3 - CP-18);
- Option 2 (remove): Abate and dispose of existing exterior wooden staircases and ladders, and close in wall openings with new framed assembly (see Section 7.2.3 - CP-18).

Fire Escape Photographs



Fig. 149

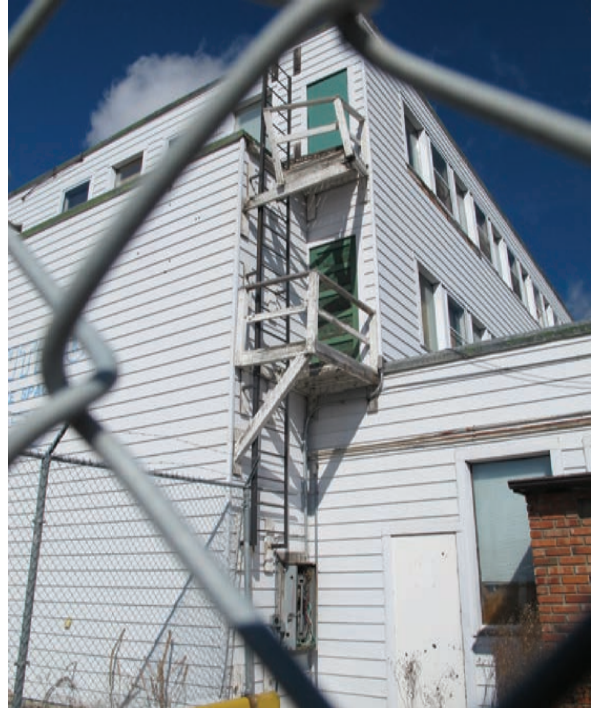

Fig. 151



Fig. 152



Fig. 153

7 CONSERVATION PLAN

7.1 Intent and Objectives

At this time, the City of Edmonton is seeking an understanding of the scope and costs involved with the conservation of Hangar 11, as an historic resource, in line with the *Standards and Guidelines for the Conservation of Historic Places in Canada*. To inform these considerations, two scopes of work have been prepared in this Conservation Plan: a Stabilization Scope which would “mothball” the building longer term, and a Conservation Scope which would prepare the building for occupancy.

Section 7.2 outlines a recommended Stabilization Scope: the scope of work required for the short-term stabilization of the building that would prevent further deterioration and address potential liabilities that could arise from long-term neglect.

Section 7.3 outlines the recommended Conservation Scope: the scope of conservation work to be carried out in the medium to longer term, with the objective of rendering the building safe, functional, and attractive to potential tenants.

Section 7.4 provides an outline of the Class D cost estimate completed by Hanscomb Quantity Surveyors (see Appendix B) for the Abatement, Stabilization, and Conservation scopes of work.

7.2 Conservation Plan for Stabilization

7.2.1 Stabilization Methodology

Stabilization Objectives

The intent of the Stabilization Plan is to reduce overall dampness in the building that threatens the survival of the extensive wood fabric and particularly the timber frame structure.

Objectives of stabilization include:

- Conservation of the heritage value and attributes of the building through minimal stabilization work;
- Reverse of deterioration and reduction of safety risks by undertaking urgent repairs to stabilize the building and avoid further loss or damage;
- Restoration of weathertightness of the building envelope;
- Analysis of the existing conditions to propose interventions to resolve issues;
- Consideration of potential natural and assisted ventilation systems, as necessary, to alter ambient conditions in the building; and,
- Preparation of the building to allow for safe tours of the facility by potential adaptive reuse partners.

Prioritization of Work

The building is currently in a state of neglect with much of its fabric not well protected from water infiltration and bio-degradation.

As a result, many of the building's Character-Defining Elements and its supporting structure remains at risk. Continued building deterioration is very likely over the next 1-5 years if no intervention is undertaken to stabilize the building.

Because significant dampness represents a risk to the building's environmental equilibrium, securing the existing fabric from further deterioration is the primary consideration of the Stabilization Plan. The conservation criteria used for setting priorities to guide this Plan are as follows:

- Structural Integrity: conditions that lead to deterioration of the building structure. Failure to maintain these items may lead to unsound conditions or potential collapse.

- Remediation: removal of vegetal growth and fungal/mould substances from interior to prevent further bio-deterioration of building components.
- Building Envelope Functionality: repair or replacement of building components which have a direct impact on main building and structural systems.
- Environmental Equilibrium: stabilization of interior humidity and temperature levels, and ongoing and methodical monitoring to establish a body of data to provide the context for informed decisions about further interventions.

The above framework has been used to inform this report's full Conservation Plan (Section 7). This report identifies immediate, short term (1 to 5 years) and medium term (6 to 10 years) required work, as part of the maintenance of the building and restoration of the exterior envelope.

Abatement

Prior to conducting any stabilization or priority repair work, trade contractors must be notified of the presence of hazardous materials and designated substances in the building, as described in the 2015 *Hazardous Materials Summary Report*, with appropriate measures and procedures taken in accordance with the laws of the Province of Alberta.

7.2.2 Stabilization Scope

The following areas have been identified to require immediate remedial work in order to maintain the existing building envelope and supporting structure. The work would be conducted following the property owner's removal of abandoned items and garbage from within the building.

The recommended stabilization work is listed in order of recommended priority:

Immediate, High Priority Repairs (0-1 years)

- SP-01 Partially abate designated substances in the building as needed to arrest mould growth and complete stabilization work below (see 2015 *Hazardous Materials Summary Report* by Golder Associates);

- SP-02 Provide temporary shoring to stabilize compromised floor structure on the west ancillary wing (third floor to foundation, engineer to confirm final locations);
- SP-03 Fully replace flat roof membrane system down to bare deck, including air/vapour barrier, underlayment, insulation, BUR membrane, related flashings and tie-ins (see roof type R1);
- SP-04 Fully replace hangar roof membrane system down to bare deck, including air/vapour barrier, underlayment, insulation, SBS membrane, and related flashings and tie-ins (see roof type R2);
- SP-05 Remove water saturated batt insulation, vapour barrier and ceiling finishes at underside of flat roofs;
- SP-06 Remove water saturated batt insulation, vapour barrier and drywall finishes from exterior walls;
- SP-07 Remove water saturated ceiling and floor finishes from west wing, down to bare floor deck;
- SP-08 Re-connect temporary power and run multiple floor dryers, industrial portable blower fans and dehumidifier units at each floor and several within the main hangar space;
- SP-09 Provide minimum temporary heat within the building (5°C) during winter and shoulder seasons using flameless construction heaters;
- SP-10 Install digital hygrothermographic sensors at multiple points in the building to measure temperature and humidity levels for full cycle of seasons (1 year);
- SP-11 Install temporary plywood sheathing at interior side of all ground floor windows;
- SP-12 Install fire and security surveillance/warning system, monitored as part of site management;
- SP-13 Install exterior wall-mounted commercial flood lights around building for security;
- SP-14 Provide temporary string work lights in all interior corridors and main hangar space.

Short-Term, Low Priority Repairs (1-5 years)

SP-15 Fully replace caulking joints at windows, flashings and roof penetrations.

The attached report from RJC provides additional scope recommendations for this phase (see Appendix E).

7.2.3 Stabilization Follow Up

Selective Demolition

In addition to the required abatement procedures and immediate repair/replacement needs, it is recommended that sections of building finishes be removed in a systematic manner throughout the building to allow a thorough assessment of concealed conditions, including the condition of wood structural members.

Depending on the findings of further detailed assessment, material analysis and destructive investigation, additional immediate stabilization work may be required, which would influence the timeline and costing, and/or the ability to preserve certain building components.

Monitoring Plan

Following completion of the priority stabilization work, it is recommended that a digital hygromograph be used to measure the temperature and relative humidity levels throughout the building for a full cycle of seasons (see Section 7.2.2 - SP-10).

This will document the changes that occur and ensure that they are within the predicted range and there have been no adverse effects of the stabilization work.

The measurements obtained from the hygromograph will also give an indication as to whether additional mechanical ventilation is required to maintain a balanced indoor air equilibrium over the long term. On the basis of the above recommendation, hygromographic sensors would be installed in several locations throughout the building to allow for continued monitoring of the target areas.

Should humidity levels be found to be too high within the building, a temporary ventilation system will need to be installed to ensure the appropriate circulation of dry air and reduction of moisture.

General Maintenance and Security

Further to the stabilization and monitoring plan outlined above, we recommend that the following ongoing maintenance guidelines be implemented for as long as the building remains unoccupied, in order to provide sufficient security and protection to the buildings and improve their overall resistance to the elements:

- Provide regular security and surveillance walk-arounds;
- Inspect roofs to ensure that drains are clear and that roof membrane and flashings are in serviceable condition (every 6 months);
- Provide a minimum level of heat during winter and shoulder months to keep interior temperature above 5°C; and,
- Regularly check relative humidity and temperature at various points within the building to monitor the success of interventions during the stabilization phase.
- If humidity levels warrant further action, install a temporary ventilation system to expel moist air and circulate dry air.

7.3 Conservation Plan for Occupancy

In order to partially or fully conserve and rehabilitate Hangar 11 to accommodate new uses, a minimum scope of conservation work will be required.

The Conservation Scope outlined in this section would render the building code compliant, functional, and suitable for leasing.

This Conservation Scope could be undertaken either independently by the City of Edmonton, by the City in concert with an eventual tenant, or by a future owner of the building.

7.3.1 Conservation Methodology

Conservation Objectives

The Conservation Scope is intended to accurately restore the building's structure, envelope and related components to ensure the property's long-term durability, and to return it to a sound and weathertight state for occupancy.

Construction methods and standardized materials should be chosen in an effort to rehabilitate the existing assemblies based on the existing sizes, profiles, materials and details, while leaving intact as much of the original fabric as possible.

Objectives of conservation include:

- The extensive replacement of the building envelope, with local repairs to the existing sheathing, to restore weathertightness;
- Building envelope repairs and upgrades that are physically and visually compatible with the building's original fabric and Character-Defining Elements;
- The full replacement of exterior windows and doors through sensitive design and upgrading;
- The conservation of the property's heritage value and Character-Defining Elements;
- Minimal intervention solutions during a potential future adaptive reuse process;
- An upgrade for universal accessibility that is as subtle and visually unobtrusive as possible.

7.3.2 Primary Conservation Scope

Inclusions/Exclusions

The future use for Hangar 11 will ultimately determine the final scope and budget for the building's conservation work.

Because the building's future use is as yet undetermined, the following recommendations outline the minimum scope of work required to conserve Hangar 11 in its shell condition. The scope reviews its structure, mechanical and electrical systems, access/egress and accessibility modifications, envelope, roof and interior finishes, to prepare the building for occupancy.

The Conservation Scope, as outlined here, does not include the scope of work required for the building's basic stabilization. Any work undertaken from the scope below would need to follow the majority of work outlined in the Stabilization Scope in Section 7.2.2.

The Conservation Scope does not currently include the restoration of the rolling exterior door system, the reconstruction of the historic control tower, and/or any potential build-out for program requirements, as these works may be dependent on the building's future use. It does not include structural repairs (e.g. wood framing, substructure/foundations), required repairs that may result from concealed or unknown conditions, or site work.

The following areas have been identified to require conservation work in order to restore building performance and support full occupancy inside the building, which are listed in order of recommended priority:

Medium-Term, Low Priority Repairs (6-10 years)

- CP-01 Strip existing painted timber post-and-beam structure down to bare wood substrate, consolidating decayed areas as needed;
- CP-02 Strip paint from existing chimney and fully repoint masonry joints, replace up to 15 damaged bricks; fabricate new precast concrete capstone to match existing;
- CP-03 Provide all new base flashings for chimney stack;
- CP-04 Freight elevator:
 - Option 1 (refurbish): Refurbish freight elevator in west ancillary wing (keep non-operational);

Option 2 (replace): Replace existing freight elevator w/
functioning elevator system; (see Section 7.2.3 - CP-04);

CP-05 Clean existing floor slab, lightly polish and seal w/ clear
penetrant;

Required Code/Occupancy Upgrades

CP-06 Fully abate designated substances inside building (see 2015
Hazardous Materials Summary Report by Golder Associates);

CP-07 Abate and dispose of all remaining non-structural interior
partitions, drop ceilings, deteriorated floor and wall finishes
in ancillary wings, and remove all redundant building services;

CP-08 Remove existing deteriorated sections of floor on the west
ancillary wing and infill with new wood floor structure;

CP-09 Apply 2 coats of intumescent paint to exposed timber post-
and-beam structure and bowstring trusses for fire protection;

CP-10 Strip existing paint from interior hangar walls, replace
deteriorated wall panels with matching plywood panels,
paint 1 coat primer, 2 coats acrylic latex enamel;

CP-11 Clean, repair and restore (17) interior hangar-facing wood
windows by repairing wood decay, re-painting exterior and
interior surfaces and replacing putty and sealant around
window frames. Replace windows to match where required;

CP-12 Install wood storm windows on office-facing side of (17)
original wood windows to improve thermal efficiency and
reduce condensation;

CP-13 Replace contemporary aluminium windows and provide
(276) new metal-clad wood double hung windows to match
original one-over-one sash frames;

CP-14 Replace (24) exterior doors with new insulated metal doors
with hardware, locksets;

CP-15 Abate and dispose of ceiling panels in hangar;

CP-16 Provide new wall, floor and ceiling finishes throughout
ancillary wings where floors are not being refurbished;

CP-17 Remove existing cladding system down to sheathing and provide new rainscreen assembly (see wall type W1), including flashings; provide local replacement/repairs to underlying diagonal wood board sheathing as needed;

CP-18 Exterior Wood Fire Escapes:

- Option 1 (rebuild): Abate and dispose of existing exterior wooden staircases and ladders and rebuild (4) existing exterior wooden staircases and (3) existing exterior wooden ladders to match;
- Option 2 (remove): Abate and dispose of existing exterior wooden staircases and ladders, and close in wall openings with new framed assembly;

CP-19 Hangar Doors:

- Option 1 (rebuild): Rebuild hangar doors with new steel or glue-laminated timber frame, insulate with spray foam, new sheet metal cladding over pressure-treated plywood substrate to match original appearance, and provide new automated track system and rollers;
- Option 2 (refurbish): Strip down existing hangar doors to bare timber frame, re-insulate with spray foam, provide new sheet metal cladding over pressure-treated plywood substrate to match original appearance, provide new automated track system and rollers;
- Option 3 (fix in place): Partially refurbish existing hangar doors to prevent further deterioration. Reinstall and fix in place as a non-functional historic artefact. Enclose hangar door openings with new contemporary glazing system;

CP-20 Laminated wood embeds at ground floor concrete slab:

Option 1 (patch): Remove and patch with new poured concrete, and make good all surfaces;

Option 2 (replace): Remove and replace in-kind w/ pressure-treated wood, and make good all surfaces;

CP-21 Patch saturated areas of plywood subfloor with new pressure-treated plywood;

- CP-22 Remove embedded wood trench drain and replace with new industrial steel trench drain cover plate to match;
- CP-23 Refurbish wood flooring in east ancillary wing, as well as south half of second floor in west wing; locally replace missing or damaged floor boards as needed;
- CP-24 Provide local patch repairs to concrete floor slab where cracking or superficial damage has occurred;
- CP-25 Install 2-stage fire alarm and life safety systems, system controls, new power and telecommunications services, lighting, HVAC, plumbing, sanitary services, stormwater management and automatic sprinkler system throughout;
- CP-26 Provide new exterior lighting;
- CP-27 Provide new washrooms and accessibility upgrades;
- CP-28 Provide other code updates, including, but not limited to:
- Provision of two (2) new passenger elevators (one for each ancillary wing), providing a barrier free path of travel;
 - Reconstruction of each of the existing four (4) interior stair cores, with fire separations having a resistance rating of 1-hour;
- CP-29 Retain, or salvage and reuse, original interior wood panel doors. Strip doors to bare wood surface and repaint;

Code Compliance

Constructed in 1942-43, Hangar 11 is not currently in conformance with the 2019 National Building Code (Alberta Edition) standards “ABC 2019”). The study attached in Appendix D provides an overview of the building’s non-compliance. It offers a discussion of future occupancy options that may be considered, given the building’s combustible construction in relation to its height and area.

The study additionally provides a minimum scope description for the primary base building code upgrades, with the objective of defining potential costs for a building conservation project.

In determining the minimum building upgrades required to meet the ABC 2019, there are limitations in understanding the potential scope due to the magnitude of possible design variations and methods of construction. As such, the Summary of Scope of Work Required for Compliance with ABC 2019 included in Appendix D, Part 3 is not exhaustive of all code upgrades that may be required for full occupancy. Rather, Appendix D provides a minimum scope description for the primary base building code upgrades that would likely be required as part of any conservation project.

7.3.3 Secondary Conservation Scope

Building Performance Upgrades

The strategy informing the Primary Conservation Scope (Section 7.3.2) involves the repair and rehabilitation of original fabric, where possible, to meet minimum code standards. It does not propose to introduce best-practice performance or functional upgrades.

A future determination may be made to pursue additional building enhancements, which might include the use of higher-efficiency/energy-saving components, or other functional and aesthetic upgrades that may influence the building's marketability or meet municipal objectives like green standards.

Heritage Interpretation

The Primary Conservation Scope (Section 7.3.2) additionally does not include the restoration of Character-Defining Elements beyond those that comprise core structural/architectural features, the salvaging of historical fixtures, nor the incorporation of interpretive materials (e.g. signage) that would be recommended for the building's conversion for occupancy once a future use is determined.

While the building is well positioned to convey its heritage value through its physical appearance as a 1940s hangar, future use discussions are encouraged to consider how the property's heritage value might be conveyed through strategies including:

- Restoration or interpretation of Character-Defining Elements beyond those addressed in the Stabilization and Conservation Scopes (e.g. antique mechanical works like the building's original air handling units, base of the former control tower);

- Where Character-Defining Elements are required to be removed (due to their condition or the building's future-use requirements), they can be replaced in-kind and/or salvaged to be displayed as historical artefacts;
- Interior or exterior art pieces;
- Photographic and/or audiovisual/multi-media displays; or,
- Restoration or interpretation of historic signage (e.g. U.S. Army Air Force, Northwest Industries).

Following the determination of the building's future use, an Interpretation Plan is recommended to be developed to ensure that Hangar 11's heritage value will be conserved and conveyed holistically throughout the site.

7.4 Cost Estimates

Hanscomb Quantity Surveyors completed a Class D Estimate, based on the Conservation Drawing Package issued to them on October 22, 2019.

Hanscomb's report defines the Class D estimate as having an expected degree of accuracy of +/- 50%. In other words, bid results might vary by this amount if the construction budget were set at this milestone estimate. In addition, design and construction contingencies are added to the budgeted amounts and are intended to account for the potential work that we are unable to determine due to the unknown future project needs.

The project cost estimate is expressed as three (3) separate items:

1. Hazardous Material Abatement:

The scope of work for hazardous material abatement is based on the 2015 report by Golder Associates, Hazardous Building Materials Assessments – Former Building 3, 11 and 39 (Blatchford Redevelopment, Edmonton, Alberta). A large portion of the hazardous material abatement includes removing mould and saturated materials exhibiting various stages of decomposition, that have a significant impact on the stabilization of the building. There may be portions of the hazardous material abatement that could be deferred to the conservation scope of work/ construction phase; however, abatement, selective demolition and encapsulation are often integrally linked and difficult to break out in separate phases of construction. Therefore, for the purposes of the Class D costing report, the costs for hazardous material abatement are combined into one value.

The sub-total construction cost estimate (including contingencies) for hazardous material abatement is: **\$887,600.00.**

2. Stabilization

The scope of work for stabilization is based on costs associated with the work required to stabilize the building from further degradation and protect the building asset. However, the building will not be an occupiable structure. An itemized list of scope items is provided on drawing page C0.1 of the Conservation Drawing Set (see Appendix C).

The sub-total construction cost estimate (including contingencies) for building stabilization is: **\$7,688,300.00.**

The sub-total construction cost estimate (including contingencies) for additional structural work in relation to the stabilization scope

(as identified in RJC's Structural Assessment report of September 2019) is: **\$6,342,100.00.**

3. Conservation

The scope of work identified for building conservation is intended to restore and conserve the building's interior finishes, and exterior envelope, including its character-defining elements. The conservation scope of work is not exhaustive of all code upgrades that may be required for full occupancy, but provides a minimum scope description for the primary base building code upgrades that would likely be required as part of any conservation project. An itemized list of scope items is provided on drawing page C0.1 of the Conservation Drawing Set (see Appendix C).

The sub-total construction cost estimate (including contingencies) for building conservation is: **\$27,926,400.00.**

The sub-total construction cost estimate (including contingencies) for additional structural work in relation to the conservation scope (as identified in RJC's Structural Assessment report or September 2019) is: **\$2,752,200.00.**

The total estimated Class D construction estimate (including contingencies) for all hazardous material abatement, stabilization and conservation is **\$45,596,600.00.**

Exclusions

Costs for the removal of any underground fuel tanks, site remediation, site development, and new utilities (water, sewer, drainage), have not been evaluated as part of the scope of work for the estimate. Refer to Appendix B of this document for the detailed Class D Estimate and full list of exclusions.

8 MAINTENANCE PLAN

8.1 General Maintenance Plan

In addition to the work outlined in the Conservation Plan in Section 7, a regular inspection and maintenance program is recommended to be implemented to ensure the long-term durability of the building. This work is intended to protect the site from damage related to failure, wear, or change resulting from regular use and the environment. The following is an outline of the recommended scope of work for ongoing general maintenance of the property.

Yearly

- Inspect the building envelope for damage sustained from weather events, disturbance by animals, vandalism and damage due to human occupancy that may compromise its condition if left unrepaired;
- Perform regular inspection of building services, life safety/security systems; and,
- Inspect roofs to ensure drains are clear (every 6 months).

Every 3-5 Years

- Complete an updated condition assessment of the buildings to evaluate the performance of the building envelope, windows and doors, flashings, roofing and adjacent grade conditions.

Every 5-10 Years

- Puttying of interior-facing wood windows, renewal of caulking, inspection of operating hardware and weather stripping .

Every 10-20 Years

- Replacement of roofing membrane and flashings;
- Selective repointing of chimney; and,
- Clean building (every 20 years).

The creation of a maintenance log with regular entries of inspection and maintenance activity is key to refining the timeframes for maintenance work, as the particular configuration and features of the building will provide their own rhythm of requirements to ensure ongoing conservation.

9 FUTURE USE OPPORTUNITIES

9.1 Zoning for Hangar 11

The Hangar 11 property is currently zoned MA2: Municipal Airport Business Industrial Zone. The zone was established as an adjacency to the runways and taxiways at Edmonton City Centre Airport, which reflected both the uses permitted in the Municipal Airport (MA) Zone and some additional Business Industrial zone uses.

Given the impending Blatchford Field redevelopment, directed by the City Centre Area Redevelopment Plan, there is an understanding that should City Council direct that the Hangar 11 property be retained, it would be rezoned to accommodate new uses reflective of its evolving context.

Upcoming redevelopment plans will position Hangar 11 between the new community of Blatchford, and the eastward expansion of the NAIT campus. Directly to the west, the City of Edmonton is developing an expansion to the LRT Metro Line NW. Through Blatchford, the LRT extension is envisioned as an urban-style system with an exclusive pedestrian/transit corridor. The surrounding NAIT lands will combine student residences, institutional and mixed-use buildings. Hangar 11 will be accessible from 109th St NW, and via a pedestrian-oriented network of green streets, cycle paths, and the LRT.

Future use determinations will guide decisions around Hangar 11's rezoning. Given the future site context, however, a Direct Development Control Provision (DC1) may allow the greatest flexibility to develop unique land use opportunities for the site. The purpose of this Provision is to:

provide for detailed, sensitive control of the Use, development, siting and design of buildings and disturbance of land where this is necessary to establish, preserve or enhance:

- *areas of unique character or special environmental concern, as identified and specified in an Area Structure Plan or Area Redevelopment Plan; or*
- *areas or Sites of special historical, cultural, paleontological, archaeological, prehistorical, natural, scientific or aesthetic interest, as designated under the Historical Resources Act.*

9.2 Options for Adaptive Reuse

Hangar 11's typology lends itself to a number of options for reuse. Some precedents include:

- The Curtiss-Wright Hangar in Columbia, SC, now the Hunter-Gatherer Brewery and Taproom;
- The Spruce Goose Hangar in Los Angeles, now a Google HQ office building;
- The DeHavilland Aircraft Co. Hangar at Downsview Park, now The Hangar, a multi-sport recreational facility and event space.

The adaptive reuse of comparably-sized shell buildings also offers precedents for food-and-craft markets, multi-functional college/university campus buildings, film/production studios, and community hubs.

The potential adaptive reuse of Hangar 11 should consider:

- Different occupancy models (e.g. one where a single large user occupies the site, or one where multiple smaller users occupy the site together);
- Various ownership/stewardship models, including public sector, private sector, arm's-length agency, not-for-profit, educational institution, or some combination of these;
- Various phasing strategies, including phased occupancy to (a) save on up-front costs, and (b) animate the site early on and draw public attention/engagement to generate new interest in the future reuse of the rest of the site.

The impending Blatchford neighbourhood redevelopment offers an opportunity to retain remnant aviation heritage on site while creatively introducing uses that are compatible with the future site context. Hypothetical 'model' scenarios for Hangar 11's reuse, and adaptive reuse precedents for this site which are comparable in either scale, building type or form, redevelopment context or other, are included in Appendix F.



Hunter-Gatherer Brewery, in the Curtiss-Wright Hangar in Columbia, SC (HG Brewery).



Google HQ in the Spruce Goose Hangar, Los Angeles (Dezeen, 2018).



A soccer field at The Hangar rec facility at Downsview Park (SouthsideCondos.com).



The Forks Market, in the comparably-sized former railyard stable at the Forks in Winnipeg, MB (TheForks.com).

10 CONCLUSION

Hangar 11 is an aircraft hangar constructed in 1942-43 for the United States Army Air Force detachment at Edmonton's Blatchford Field. The hangar was used briefly to support the Northwest Staging Route, which systematically transferred aircraft and materials to Alaska to support to war effort on the Eastern Front. Hangar 11 was subsequently used for three decades by Northwest Industries Ltd., a local firm engaged in national military and commercial aircraft repair and development contracts. This report concludes that Hangar 11 carries significant heritage value.

Today, Hangar 11 remains at Edmonton's Blatchford Field, Canada's first municipal airport and at one point the busiest in North America. Hangar 11 serves as one of the few remaining buildings that can yield evidence of Blatchford Field's local, national, and international heritage value.

Hangar 11 is listed on Edmonton's Inventory of Historic Resources. It exists today within a policy context that encourages the City of Edmonton to retain, restore, and designate its own historic resources (Historic Resources Management Plan, 2009) and that directs the Blatchford redevelopment to conserve and repurpose hangars on site (City Centre Area Redevelopment Plan, 2012), several of which have since been demolished.

This report's Condition Assessment finds that the building's shell and supporting structure is generally in fair condition, with the exception of several areas, mainly in the west ancillary wing, which are in very poor condition and require extensive structural repairs as noted in RJC's Structural Assessment. While the cladding and finishes are generally in poor or defective condition, the central features of the building's character are generally intact with some degradation, including the building's unique timber structural frame and curved wood bowstring trusses. Overall, the building shows high potential for restoration and reuse.

This report's Conservation Plan finds that Hangar 11 may be conserved according to two potential scenarios: one where the building is stabilized to allow for long-term mothballing by the City, and another where the building is prepared for occupancy. Scopes of work and cost estimates are provided in Section 7 for both options. Either option will allow the City of Edmonton to conserve Hangar 11's heritage value in the longer term.

It is recommended that local stakeholders and prospective partners be engaged in determining future use options for Hangar 11. Workshops and discussions around Hangar 11's reuse may yield opportunities for collaboration, both in financing the building's conservation, and in its future occupancy. These discussions will allow stakeholders to explore future uses that could animate the building, allowing visitors to experience its history and its contribution to Edmonton's heritage.

11 PROJECT PERSONNEL

Scott Weir OAA MArch CAHP LEED AP
Principal, ERA Architects Inc.

Peter Osborne MArch Architect AAA AIBC SAA MAA FRAIC LEED AP
Partner, GEC Architecture Inc.

Ryan Love OAA LEED AP
Associate, ERA Architects Inc.

Alexis Finlay MArch Architect AAA LEED AP
Associate, GEC Architecture Inc.

Alexis Cohen PhD CAHP
Associate, ERA Architects Inc.

Sanford Riley MArch MSc BA
Project Manager, ERA Architects Inc.

Emma Abramowicz MPI BAH
Planner, ERA Architects Inc.

12 REFERENCES

- (1920, Apr 26). Municipal aerodrome vital if city is to hold lead, air officers tell mayor: Lt-Col. J. S. Scott points out that after May 17 no licensed pilot will be allowed to land except at proper air harbor. *Edmonton Journal*, pg. 1. Retrieved from <https://www.newspapers.com/>.
- (1920, May 10). Permit secured by Aircrafts Co. for new aerodrome: Structure costing \$2000 will be located at 118th Ave. and 119th St. *Edmonton Journal*, pg. 12. Retrieved from <https://www.newspapers.com/>.
- (1920, Jun 8). See Edmonton from the Air [ad.]. *Edmonton Journal*, pg. 7. Retrieved from <https://www.newspapers.com/>.
- (1920, Jun 12). British machines arrive. *Edmonton Journal*, pg. 38. Retrieved from <https://www.newspapers.com/>.
- (1926, Jun 2). Brisk demand for tax sale property: Dwellings will be built on lots secured in trades. *Edmonton Journal*, pg. 13. Retrieved from <https://www.newspapers.com/>.
- (1926, Sep 25). New city golf course: Links proposed near Portage Ave. *Edmonton Journal*, pg. 13. Retrieved from <https://www.newspapers.com/>.
- (1926, Nov 23). "Blatchford Field" is name chosen for new municipal aerodrome: Mayor promises to make effort to have aeroplane station at High River moved to Edmonton - Farewell address to Council. *Edmonton Journal*, pg. 1. Retrieved from <https://www.newspapers.com/>.
- (1927, Jan 8). Municipal aerodrome, first in all Canada is officially opened: Two aeroplanes from High River Station arrived today; officers and mechanics received souvenir cigarette cases from City of Edmonton. *Edmonton Journal*, pg. 1. Retrieved from <https://www.newspapers.com/>.
- (1927, Feb 26). City of Edmonton: For Lease - The land owned by the city in New Hagman and Summerwilde Subdivisions, now known as the "Blatchford Air Field"... [ad.]. *Edmonton Journal*, pg. 7. Retrieved from <https://www.newspapers.com/>.
- (1927, Mar 19). Up in the Air with Punch Dickins: Edmonton aviator has proven winter flying here is practicable. *Edmonton Journal*, pg. 35. Retrieved from <https://www.newspapers.com/>.
- (1929, Nov 26). Aviation progress of city offers convincing reason for passing airport bylaw. *Edmonton Journal*, pg. 13. Retrieved from <https://www.newspapers.com/>.
- (1939, Mar 25). Airport growth rapid in 10 years: Is considered one of finest in all Canada. *Edmonton Journal*, pg. 49. Retrieved from <https://www.newspapers.com/>.
- (1939, Apr 20). 39 Airplans at city port for break-up: Total greater than that for air show, Capt. Bell believes - Space is problem - Hangars cannot accommodate all of machines for overhaul. *Edmonton Journal*. Retrieved from <https://www.newspapers.com/>.
- (1939, Jun 1). Six aviation firms maintain bases at Edmonton Airport - More than 50 planes flying out of city serve development of vast northern area: 11,000 passengers in year. *Edmonton Journal*, pg. 35. Retrieved from <https://www.newspapers.com/>.
- (1940, Jan 22). City Airport named wartime training field: Extension of runways, hangars construction to be part of scheme. *Edmonton Journal*, pg. 1. Retrieved from <https://www.newspapers.com/>.
- (1940, Mar 7). 15 new buildings planned for City Airport: Design hangar big as arena - to triple width of runways. *Edmonton Journal*, pg. 1-2. Retrieved from <https://www.newspapers.com/>.

- (1940, Apr 17). Air buildings tenders called: Two hangars, 14 other structures planned for airport. *Edmonton Journal*, pg. 1. Retrieved from <https://www.newspapers.com/>.
- (1940, Jun 15). \$210,000 airport program will be completed July 22. *Edmonton Journal*, pg. 13. Retrieved from <https://www.newspapers.com/>.
- (1940, Jun 25). Huge hangar for repairs planned here. *Edmonton Journal*, pg. 1. Retrieved from <https://www.newspapers.com/>.
- (1940, Jul 13). Push \$200,000 construction program for Observers School at City Airport. *Edmonton Journal*, pg. 1. Retrieved from <https://www.newspapers.com/>.
- (1942, Oct 20). Modern \$85,000 administration building greatly improves airport - Long-wanted need filled as structure completed - City Airport is among best equipped on continent. *Edmonton Journal*, pg. 17. Retrieved from <https://www.newspapers.com/>.
- (1942, Nov 24). Plan extension airport hangar. *Edmonton Journal*, pg. 11. Retrieved from <https://www.newspapers.com/>.
- (1943, Mar 9). \$701,500 in permits issued for airport. *Edmonton Journal*, pg. 1. Retrieved from <https://www.newspapers.com/>.
- (1943, Mar 31). Development of aviation brings city into own. *Edmonton Journal*, pg. 28. Retrieved from <https://www.newspapers.com/>.
- (1944, Jan 11). \$1,314,000 is cost on airport work. *Edmonton Journal*, pg. 1. Retrieved from <https://www.newspapers.com/>.
- (1944, May 30). Northwest Air Command. *Edmonton Journal*, pg. 4. Retrieved from <https://www.newspapers.com/>.
- (1944, Aug 17). Edmonton Air Centre is busiest in Dominion. *The Globe and Mail*, pg. 3. Retrieved from ProQuest Historical Newspapers Database, Toronto Public Library.
- (1945, Feb 20). Edmonton Airport costs to Dominion \$20,000,000. *Flight Magazine*, pg. 312. Retrieved from the City of Edmonton.
- (1945, May 7). Allied victory in Europe recalls turning points in war: War brought boom to city, turned it into busy centre. *Edmonton Journal*, pg. 9. Retrieved from <https://www.newspapers.com/>.
- (1956, Aug 24). The Canadian Industry... Northwest Industries, Ltd. *Edmonton Journal*, pg. 1. Retrieved from <https://www.newspapers.com/>.
- (1963, Nov 8). The Third Column: Airport History. *Edmonton Journal*, pg. 4. Retrieved from <https://www.newspapers.com/>.
- The Alberta Order of Excellence. *Dr. Francis G. Winspear O.C., F.C.A., LL.D.* Retrieved from: <https://www.lieutenantgovernor.ab.ca/aoe/arts/francis-winspear/index.html>.
- Biographical Dictionary of Architects in Canada: 1800-1950. *MacDonald, George Heath*. Retrieved from: <http://www.dictionaryofarchitectsincanada.org/node/1456>.
- Biographical Dictionary of Architects in Canada: 1800-1950. *Martland, John*. Retrieved from: <http://www.dictionaryofarchitectsincanada.org/node/2168>.
- Boddington, S. & Moir, S. (1995). "The Friendly Invasion": The American Presence in Edmonton, 1942-1945. In K. Tingley (Ed.), *For King and Country: Alberta in the Second World War*, pp. 177-92. Canada: Provincial Museum of Alberta.
- Christensen, J. & Shappka, D. (1999). *An Edmonton Album: Glimpses of the Way We Were*. Toronto: Hounslow Press.

- Christie, C. A. (1995). The Northwest Staging Route: A Story of Canadian-American Wartime Co-operation. In K. Tingley (Ed.), *For King and Country: Alberta in the Second World War*, pp. 213-28. Canada: Provincial Museum of Alberta.
- City of Edmonton. *Indigenous Relations*. Retrieved from: https://www.edmonton.ca/city_government/initiatives_innovation/indigenous-relations.aspx.
- City of Edmonton. (2010). *The Way We Grow: Municipal Development Plan*. Retrieved from: https://www.edmonton.ca/city_government/documents/PDF/MDP_Bylaw_15100.pdf.
- City of Edmonton. (2012). *City Centre Redevelopment Area Redevelopment Plan*. Retrieved from: https://www.edmonton.ca/residential_neighbourhoods/plans_in_effect/City_Centre_ARP_Consolidation.pdf.
- City of Edmonton - City Planning. (2018, Aug 27). *Urban Form and Corporate Strategic Development report CR_5891*. Retrieved from: <http://sirepub.edmonton.ca/sirepub/mtgviewer.aspx?meetid=1976&doctype=MINUTES>.
- City of Edmonton - Planning and Development. (2008). *City Policy C450B: Policy to Encourage the Designation and Rehabilitation of Municipal Historic Resources in Edmonton*. Retrieved from: https://www.edmonton.ca/city_government/documents/PDF/C450B.pdf.
- City of Edmonton - Planning and Development. (2009). *Historic Resource Management Plan*. Retrieved from: https://www.edmonton.ca/city_government/documents/PDF/HistoricResourcePlanMay2009.pdf.
- Commonwealth Historic Resource Management Limited. (2004). *Rosssdale Historical Land Use Study*. Retrieved from: https://www.edmonton.ca/documents/PDF/Rosssdale_Historical_Land_Use_Study_Feb_2004.pdf.
- Confederacy of Treaty Six First Nations. *Our History and Purpose*. Retrieved from: <https://www.treatysix.org/our-history>.
- David Murray Architect, Next Architecture & Tingley, K. (2017). *Report CR_5891 Attachment 3: Heritage Assessment of Hangar 11 at the former Edmonton Municipal Airport, Alberta*. Retrieved from: <http://sirepub.edmonton.ca/sirepub/mtgviewer.aspx?meetid=1976&doctype=MINUTES>.
- Elliott, P. (1944, Aug 1). Russia accepts planes from producers in U.S. at depot in Fairbanks. *The Globe and Mail*, pg. 3. Retrieved from ProQuest Historical Newspapers Database, Toronto Public Library.
- Estabrooks, T. (2014, Oct 21). Healing Garden planned to remember residential schools in St. Albert. *CBC*. Retrieved from: <https://www.cbc.ca/news/canada/edmonton/healing-garden-planned-to-remember-residential-schools-in-st-albert-1.2806893>.
- Filice, M. (2016, Oct 11). Treaty 6. *The Canadian Encyclopedia*. Retrieved from: <https://www.thecanadianencyclopedia.ca/en/article/treaty-6>.
- Giang, P. (2013, Nov 28). Celebrating Blatchford. *Spacing Edmonton*. Retrieved from <http://spacing.ca/edmonton/2013/11/28/celebrating-blatchford-field/>.
- Gilmour, B. (1995). The Homefront in the Second World War. In B. Hesketh & F. Swyripa (Eds.), *Edmonton: The Life of a City* (pp. 212-25). Edmonton: NeWest Publishers Ltd.
- Golder Associates Ltd. (2015). *Hazardous Building Materials Assessments - Former Building 3, 11 and 39 (Blatchford Redevelopment, Edmonton, Alberta)*. Retrieved from the City of Edmonton.

- Hall, D. J. (2015). *From Treaties to Reserves: The Federal Government and Native Peoples in Territorial Alberta, 1870-1905*. Montreal: McGill-Queen's University Press.
- Heide, R. L. *The British Commonwealth Air Training Plan*. Veterans Affairs Canada. Retrieved from: <https://www.veterans.gc.ca/eng/remembrance/history/second-world-war/british-commonwealth-air-training-plan>.
- Hopkins, M. (1995). Blatchford Field: The War Years, 1939-1945. In K. Tingley (Ed.), *For King and Country: Alberta in the Second World War*, pp. 229-42. Canada: Provincial Museum of Alberta.
- Laghi, B. (1997, Feb 10). Lives lived: Francis George Winspear. *The Globe and Mail*, A16. Retrieved from ProQuest Historical Newspapers Online, Toronto Public Library.
- MacDonald, J. (1984, May 18). Part of city from earliest days: Development sporadic until war came along. *Edmonton Journal*, pg. 67. Retrieved from <https://www.newspapers.com/>.
- MacGregor, J. G. (1981). *A History of Alberta: Revised Edition*. Edmonton: Hurtig Publishers Ltd.
- McCallum, G. (1943, Apr 8). Northern Trek: Goods flow unceasing day, night. *The Globe and Mail*, pg. 15. Retrieved from ProQuest Historical Newspapers Database, Toronto Public Library.
- McCallum, G. (1943, May 21). Western Air Control: New aviation traffic regulation system installed at Edmonton. *The Globe and Mail*, pg. 17. Retrieved from ProQuest Historical Newspapers Database, Toronto Public Library.
- McCallum, G. (1943, Nov 24). Soviet-bound planes cross North Canada. *The Globe and Mail*, pg. 1. Retrieved from ProQuest Historical Newspapers Database, Toronto Public Library.
- McCallum, G. (1944, Apr 27). Staging Route: Air Highway to North Still Grows. *The Globe and Mail*, pg. 13. Retrieved from ProQuest Historical Newspapers Database, Toronto Public Library.
- McCallum, G. (1944, Dec 7). Alberta Airport Continent's Largest. *The Globe and Mail*, pg. 3. Retrieved from ProQuest Historical Newspapers Database, Toronto Public Library.
- Myers, P. (1995). *Sky Riders: An Illustrated History of Aviation in Alberta 1906-1945*. Saskatoon: The Friends of Reynolds-Alberta Museum Society and Alberta Community Development.
- Myers, P. (1995). Watching the War Fly By: The British Commonwealth Air Training Plan in Alberta. In K. Tingley (Ed.), *For King and Country: Alberta in the Second World War*, pp. 243-253. Canada: Provincial Museum of Alberta.
- Native Land Digital. *Native Land* [map]. Retrieved from: <http://native-land.ca>.
- Next Architecture Inc. (2017). *Building Conservation Plan: Alberta Aviation Museum*. Retrieved from the City of Edmonton.
- Parks Canada. (YEAR) *Standards and Guidelines for the Conservation of Historic Places in Canada*. Retrieved from: <https://www.historicplaces.ca/media/18072/81468-parks-s+g-eng-web2.pdf>.
- Province of Alberta. *Evaluating Historic Places: Eligibility, Significance and Integrity*. Retrieved from: <https://open.alberta.ca/dataset/e761cb3d-d170-475a-8fde-84973c76cc70/resource/94c20231-dae9-4808-b41e-d001ac07b481/download/7029258-2010-Evaluating-Historic-Places-Eligibility-Significance-Integrity.pdf>.
- Richardson, B.T. (1939, Jan 10). West's Fastest Growing City: B. T. Richardson in Saskatoon Star-Phoenix. *Edmonton Journal*, pg. 4. Retrieved from <https://www.newspapers.com/>.

- S2 Architecture, RJC Consulting Engineers, Smith + Andersen, & SMP Engineering. (2017). *Report CR_5891 Attachment 4: Condition Assessment Report - Hangar 11 - 11713 190 St. NW, Edmonton, Alberta*. Retrieved from: <http://sirepub.edmonton.ca/sirepub/mtgviewer.aspx?meetid=1976&doctype=MINUTES>.
- Smith, P. J. & Sholdice, M. (2006, Mar 24. Edited 2019, Mar 6). Edmonton. *The Canadian Encyclopedia*. Retrieved from: <https://www.thecanadianencyclopedia.ca/en/article/edmonton>.
- Spencer, C. (2008, Jul 6). On gilded wings of glory. *Edmonton Journal*, pg. 45, 48-49. Retrieved from <https://www.newspapers.com/>.
- Stamp, R. M. & Warnell, D. (2009, Mar 26. Edited 2019, Apr 23.) Alberta. *The Canadian Encyclopedia*. Retrieved from: <https://www.thecanadianencyclopedia.ca/en/article/alberta>.
- Switzer, J. (2006, Feb . Edited 2015, Mar 4). Fort Edmonton. *The Canadian Encyclopedia*. Retrieved from: <https://www.thecanadianencyclopedia.ca/en/article/fort-edmonton>.
- Tingley, K. (2009). *Historical Impact Assessment: A Thematic Overview Narrative for City Centre Airport*. Retrieved from the City of Edmonton.
- United Church of Canada - Steering Committee on Residential Schools. *Edmonton Indian Residential School*. Retrieved from: <https://thechildrenremembered.ca/school-locations/edmonton/>.
- Ziegler, R. (1978, Nov 21). There was rarely a dull moment in the history of Blatchford Field. *Edmonton Journal*, pg. 117. Retrieved from <https://www.newspapers.com/>.

13 APPENDICES

HANGAR 11 - BLATCHFORD

ADVANCED ASSESSMENT & DOCUMENTATION

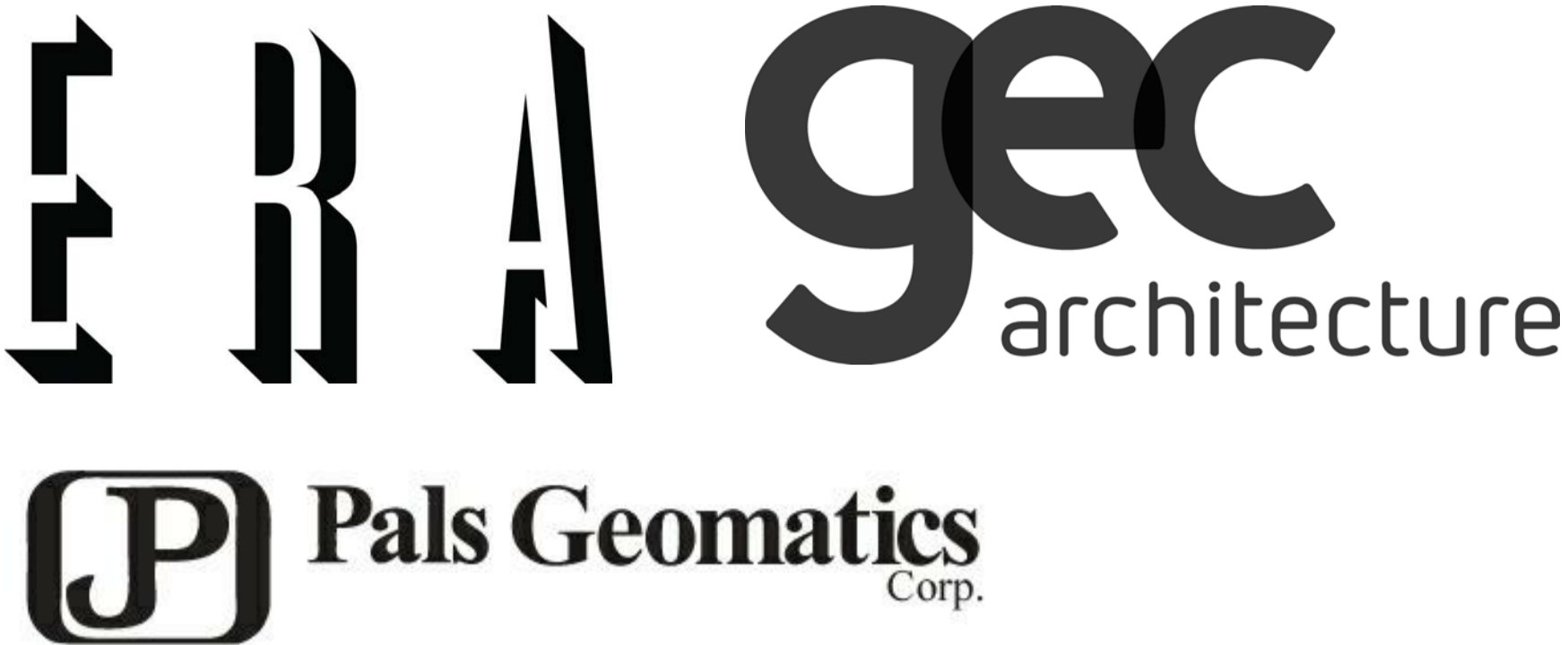

PROJECT NO.: 5719

ISSUED FOR: HISTORIC BUILDING RECORD

JUNE 27, 2019
DRAWING LIST

ARCHITECTURAL

- A000 COVER PAGE & SITE PLAN
- A200 MAIN FLOOR PLAN
- A201 SECOND FLOOR PLAN
- A202 THIRD FLOOR PLAN
- A203 ROOF PLAN
- A300 EAST EXTERIOR ELEVATION
- A301 NORTH EXTERIOR ELEVATION
- A302 WEST EXTERIOR ELEVATION
- A303 SOUTH EXTERIOR ELEVATION
- A400 BUILDING SECTIONS
- A401 HANGAR BUILDING SECTIONS
- A501 POINT CLOUD AXONOMETRIC BUILDING IMAGES

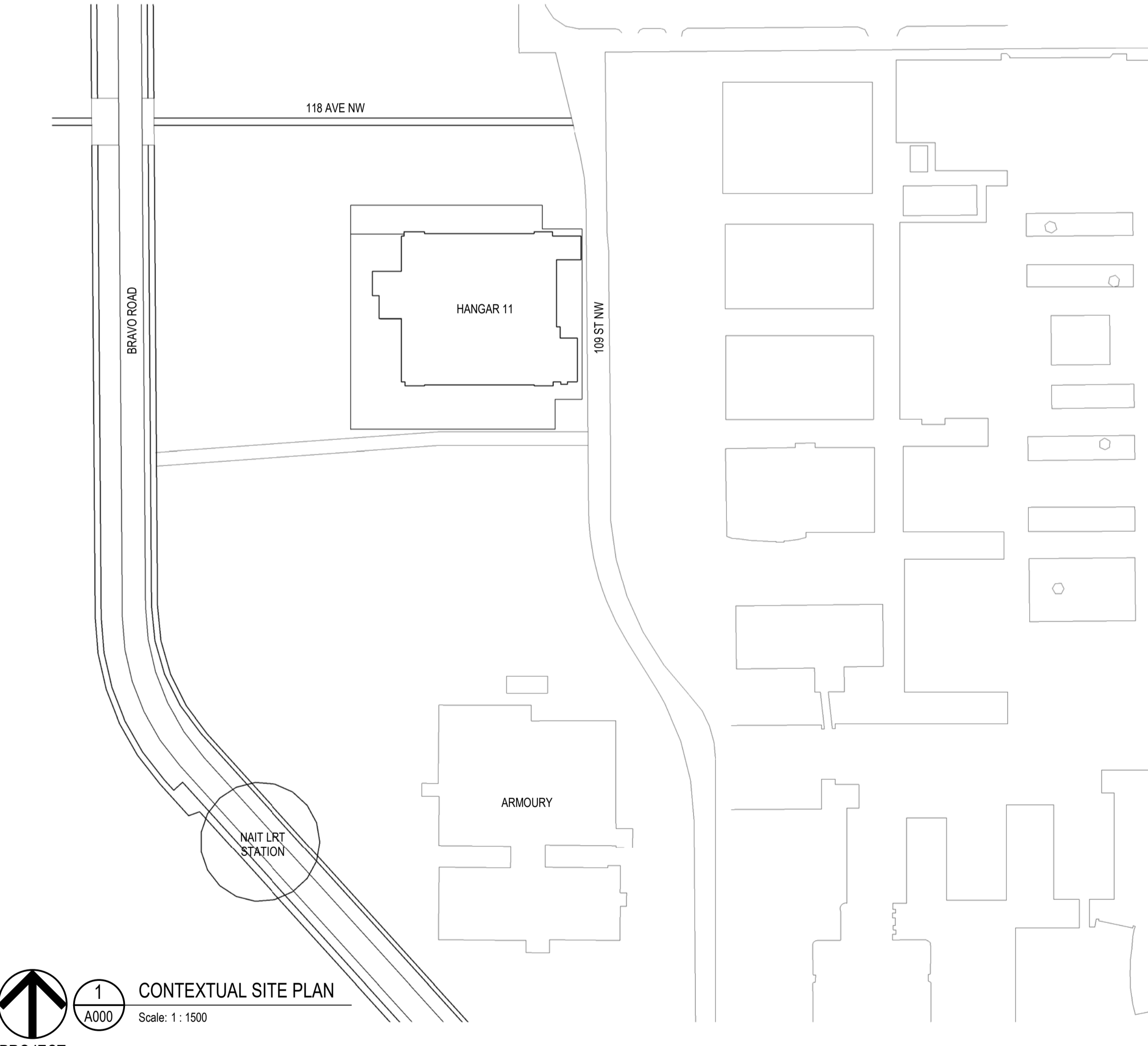

CONTEXTUAL SITE PLAN
Scale: 1 : 1500
PROJECT NORTH

PROJECT ADDRESS:

MUNICIPAL ADDRESS:
11700 - 109th STREET
LEGAL ADDRESS:
LOT 2, BLOCK 6A, PLAN 9220135 AREA 23B

BUILDING DESCRIPTION

YEAR OF CONSTRUCTION: 1942/43 BY THE UNITED STATES AIR FORCE (USAF)
HEIGHT: 3 STORIES (UNDER 18m)
AREA: 4591.84m² MAIN FLOOR (LARGEST CROSS-SECTIONAL PLAN AREA)

BUILDING AREAS:
MAIN LEVEL WEST OFFICES: 788.02m²
MAIN LEVEL HANGAR: 2971.13m²
MAIN LEVEL EAST OFFICES: 832.69m²
MAIN LEVEL TOTAL: 4591.84m²
SECOND LEVEL WEST OFFICES: 577.29m²
SECOND LEVEL EAST OFFICES: 557.29m²
SECOND LEVEL TOTAL: 1134.58m²
THIRD LEVEL WEST OFFICES: 575.09m²
THIRD LEVEL EAST OFFICES: 557.29m²
THIRD LEVEL TOTAL: 1132.38m²
ROOF PLAN: 7.5m²

THE HANGAR BUILDING IS COMPRISED OF AN OPEN CENTRAL AIRPLANE HANGAR SPACE, IS ROUGHLY 46m WIDE AND IS 64m LONG AND APPROXIMATELY 9.5m CLEAR TO THE UNDERSIDE OF THE ROOF STRUCTURE. THE MAIN HANGAR CONSISTS OF BUILT-UP LAMINATED BEAMS AND BOWSTRING TIMBER TRUSSES ON WOOD COLUMNS WITH A CONCRETE SLAB-ON-GRADE. THE NORTH AND SOUTH FACES OF THE HANGAR ARE EQUIPPED WITH LARGE ROLLING WOODEN DOORS. THESE ARE CURRENTLY INOPERABLE. THERE ARE TWO ANCILLARY OFFICE BANKS RUNNING THE LENGTH OF THE HANGAR ON THE EAST AND WEST SIDES. ANCILLARY OFFICE BANKS AND OTHER AREAS APPEAR TO BE WOOD FRAME POST AND BEAM CONSTRUCTION WITH CONCRETE SLAB-ON-GRADE. THE OFFICE BANKS ARE 3-STORIES AND ARE APPROXIMATELY 9m WIDE AND 64m LONG. A SET OF LOADING BAYS (NOT ORIGINAL), TOTALING APPROXIMATELY 203m², EXISTS ON THE WEST SIDE OF THE BUILDING. A SINGLE STORY OF GENERAL OFFICE AREA PROTRUDES FROM THE EAST ANCILLARY WING, AND IS APPROXIMATELY 171m². LASTLY, THERE IS A BOILER ROOM AT THE NORTH END OF THE EAST ANCILLARY WING, TOTALING APPROXIMATELY 93m². ROOFING CONSISTS OF BUILT-UP ROOF MEMBRANES WITH GRAVEL BALLAST ON FLAT AREAS. EXTERIOR CLADDING CONSISTS OF HORIZONTAL METAL SIDING, FINISHED WHITE, BUT IT IS UNCLEAR IF THIS IS ORIGINAL CLADDING AS RENOVATIONS AND BUILDING ALTERATIONS HAVE BEEN MADE IN THE PAST AND ARE LARGELY UNDOCUMENTED. MODEL BUILDING CODES SET OUT IN THE NATIONAL BUILDING CODE OF CANADA (NBC), WHICH WERE FIRST PUBLISHED IN 1941, WERE IN FORCE AT THE TIME OF THE HANGAR 11 CONSTRUCTION.

PROJECT DESCRIPTION

BUILT IN 1942/43 BY THE UNITED STATES AIR FORCE, THE HANGAR 11 BUILDING TELLS A MULTI-FACETED STORY CRITICALLY LINKED TO WWII AND THE HISTORY OF EDMONTON'S CULTURAL AND FINANCIAL GROWTH AND DEVELOPMENT. LOCATED ON THE SITE OF THE FORMER MUNICIPAL AIRPORT, THE HANGAR WAS CONSTRUCTED AS PART OF THE NORTHWEST STAGING ROUTE - A JOINT EFFORT OF THE AMERICAN AND CANADIAN MILITARIES THAT WOULD ENSURE DELIVERY OF WAR MATERIALS TO ALASKA AND THE SOVIET UNION. IT REMAINS ONE OF TWO REMAINING PHYSICAL REMINDERS OF THIS PERIOD WHEN THE CITY ASSUMED A SIGNIFICANT ROLE IN THE NORTHWEST CONTINENTAL DEFENSE.

THIS DRAWING PACKAGE DOCUMENTS THE HANGAR STRUCTURE IN ITS CURRENT STATE, SYNTHESIZED FROM A 3D LASER SCAN BY PALS GEOMATICS, AND BY A COMBINATION OF SITE DOCUMENTATION AND PHOTOGRAPHY. THERE ARE SIGNIFICANT BUILDING ENVELOPE ISSUES, PARTICULARLY IN THE OFFICE WING ON THE WEST SIDE OF THE BUILDING WHERE MANY CEILING WALLS AND FLOORS HAVE BEEN EXCESSIVELY DAMAGED BY MOISTURE INGRESS. AS A RESULT, MANY AREAS OF THE BUILDING WERE NOT ACCESSIBLE, SUCH AS THE ROOF, CEILING, ATTIC SPACE, AND ALL EXTERIOR EXITS, WHERE THE INTEGRITY OF THE SUPPORTING STRUCTURE COULD NOT BE VERIFIED.

THESE DRAWINGS ARE MEANT ONLY TO SERVE AS A RECORD OF THE BUILDING FORM. DRAWINGS ARE NOT INTENDED FOR CONSTRUCTION OR PERMITTING PURPOSES.

BYLAW 12800 LAND USE ZONING:

(MA2) MUNICIPAL AIRPORT BUSINESS INDUSTRIAL ZONE
THE PURPOSE OF THIS ZONE IS TO ESTABLISH A ZONE ADJACENT TO THE RUNWAYS AND TAXIWAYS OF THE EDMONTON CITY CENTRE AIRPORT, WHICH CARRIES OVER THE DEVELOPMENT RIGHTS OF THE FORMER MA ZONE AND ALLOWS SOME ADDITIONAL BUSINESS INDUSTRIAL OPPORTUNITIES, BASED ON THE IB ZONE.

GENERAL NOTES

1. DRAWINGS ARE NOT TO BE SCALED
2. ALL DIMENSIONS ARE TO BE VERIFIED ON SITE.
3. ALL MODELED ELEMENTS WERE BASED OFF OF POINT CLOUD MODEL DATA

MODEL STRATEGY & ASSUMPTIONS

1. DRAWINGS WERE PRODUCED USING INFORMATION FROM A POINT CLOUD MODEL, PRODUCED BY PALS GEOMATICS, TOGETHER WITH SITE DOCUMENTATION AND PHOTOGRAPHY.
2. ASSUMPTIONS HAVE BEEN MADE TO ENSURE SQUARENESS OF THE DRAWINGS. WALL AND PARTITION LOCATIONS MAY VARY BY A TOLERANCE OF ±400mm
3. WALLS ARE GENERIC ASSEMBLIES. WIDTH WAS ESTIMATED BASED ON POINT CLOUD DATA; NO SELECTIVE DEMOLITION OR FORENSIC INVESTIGATIONS WERE COMPLETE AS PART OF THE SCOPE OF WORK.
4. DOOR & WINDOW LOCATIONS ARE ESTIMATED BASED ON POINT CLOUD DATE.
5. LOCATION OF WATER CLOSETS AND EXISTING FIXTURES ARE APPROXIMATE. ACTUAL LOCATIONS MAY VARY. ADDITIONAL WATER CLOSETS, SINKS, BATHTUBS AND OTHER WASHROOM FEATURES INCLUDING BUT NOT LIMITED TO, DRAINS, SHOWER HEADS, MAY BE PRESENT, BUT NOT INDICATED ON THE DRAWINGS.
6. THE GRID HAS BEEN ESTABLISHED BASED ON THE EXISTING BUILDING LAYOUT AND IS AN APPROXIMATION OF EXISTING POINT CLOUD INFORMATION
7. ALL DIMENSIONS ARE FROM CENTRE LINE OF WALL U.N.O.
8. LOCATION OF WALLS WERE TAKEN BY THE FOLLOWING CUT PLANES:
EXTERIOR WALLS: 2200mm
MAIN FLOOR WALLS: 2200mm
MAIN FLOOR DOORS & WINDOWS 1500mm
MAIN FLOOR AUXILIARY STRUCTURE:
SECOND FLOOR WALLS: 2200mm
SECOND FLOOR DOORS & WINDOWS: 1200mm
THIRD FLOOR WALLS: 2200mm
THIRD FLOOR DOORS & WINDOWS: 1500mm
ROOF PLAN: N/A

SYMBOL LEGEND

⊕	CENTERLINE MARK
ROOM NAME 1001A	ROOM NAME & NUMBER
1 SIM A101	BUILDING SECTION 1 - SECTION NUMBER A101 - REFERENCE SHEET NUMBER
1 SIM A101	WALL SECTION OR SECTION DETAIL 1 - SECTION NUMBER A101 - REFERENCE SHEET NUMBER
20 A101	View Name 1 - DETAIL NUMBER A101 - REFERENCE SHEET NUMBER TITLE - DETAIL TITLE Scale: 1:100
1 A101	ELEVATION SYMBOL 1 - DETAIL NUMBER A101 - REFERENCE SHEET NUMBER

PRELIMINARY - NOT FOR CONSTRUCTION

2019-06-27 08:54 AM: 5719
100 - 109th Street NE, Edmonton, AB T7A 1A2
100 - 109th Street NE, Edmonton, AB T7A 1A2

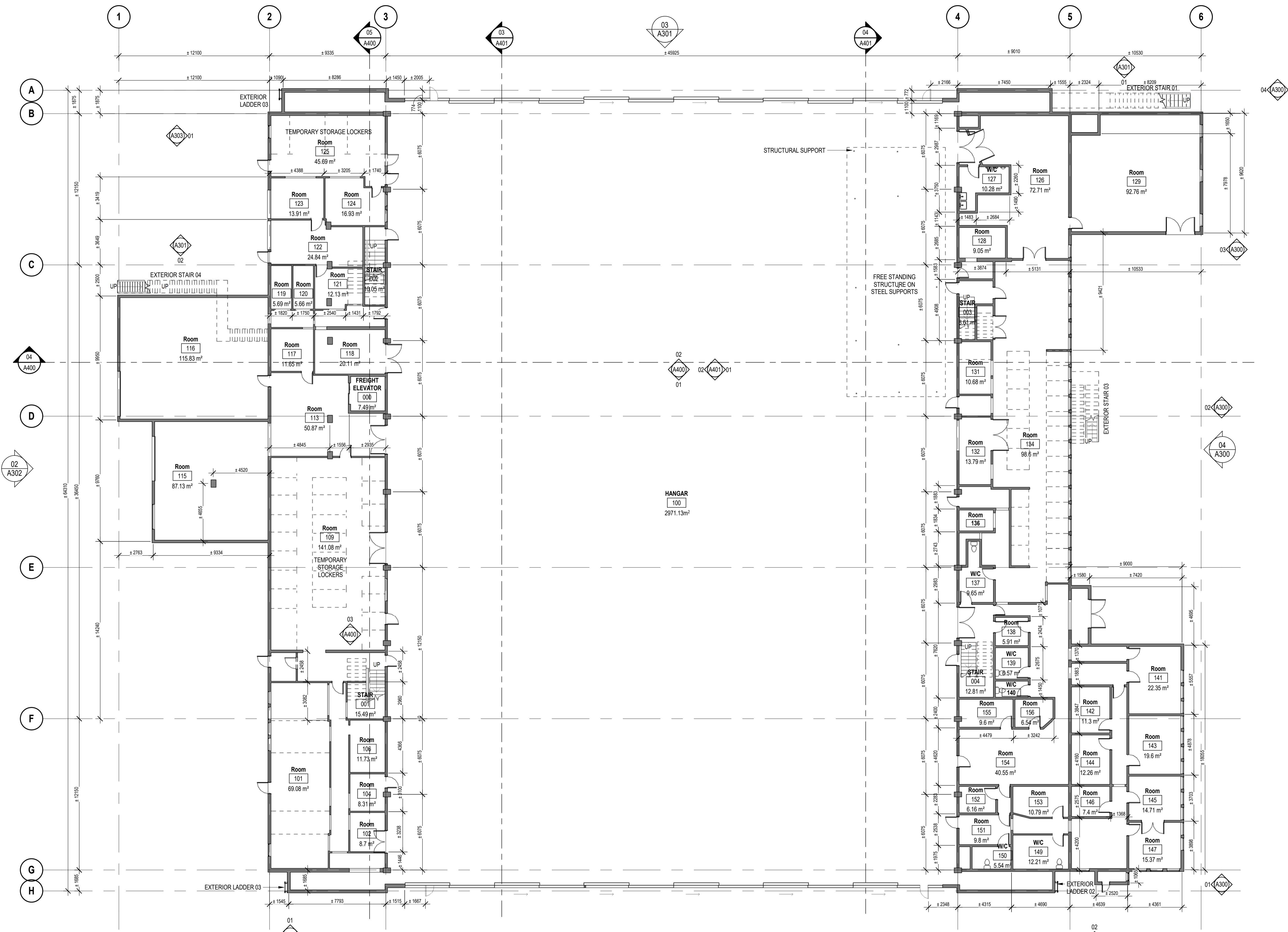

1 LEVEL 1 FLOOR PLAN
 Scale: 1:150
 PROJECT NORTH

PRELIMINARY: NOT FOR CONSTRUCTION

REV #	DESCRIPTION	DATE	CHECKED
02	ISSUED FOR HISTORIC RECORD	27/06/2019	AF
01	ISSUED FOR PROGRESS REVIEW	08/05/2019	AF

ISSUE DATA	DATE

PERMIT:
 SEAL:
 SEAL:

CONSULTANT: **gec architecture**
 CONSULTANT PROJECT NO: 5719

THE CITY OF **Edmonton** INTEGRATED INFRASTRUCTURE SERVICES

PROJECT: **HANGAR 11 - BLATCHFORD
 ADVANCED ASSESSMENT
 & DOCUMENTATION**

BUILDING CODE:
 LOCATION: ADDRESS NW, EDMONTON, AB

DRAWING TITLE: **MAIN FLOOR PLAN**

SCALE: AS SHOWN ALL DIMENSION ARE IN MILLIMETRES	PROJECT NO: CP-####
DRAWN BY: Author DATE: Issue Date	DRAWING NO: A200
CHECKED BY: Checker DATE: Issue Date	
REVIEWED BY: Approver DATE: Issue Date	
FILE NAME:	

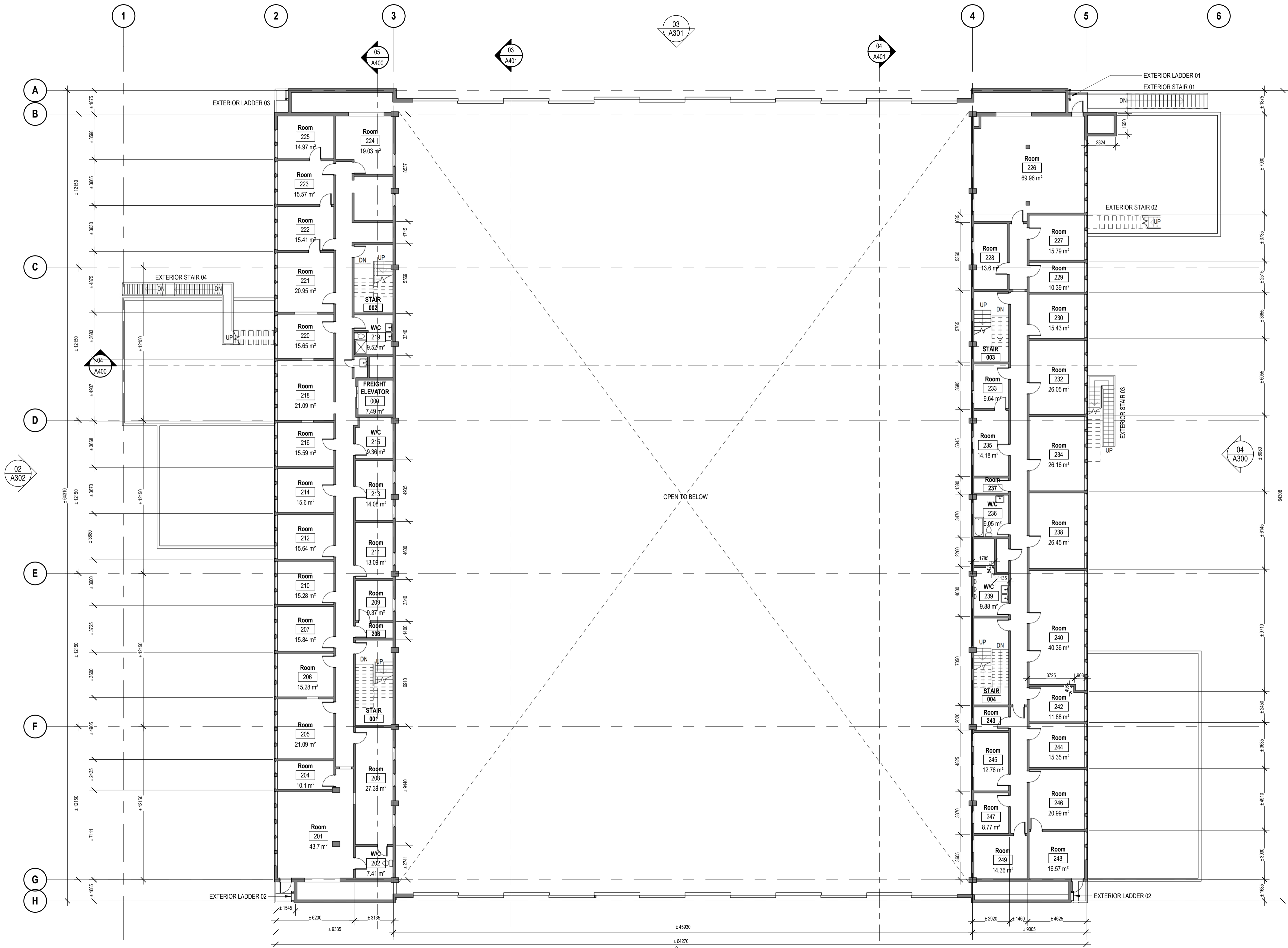

1 LEVEL 2 FLOOR PLAN
 Scale: 1:150
 PROJECT NORTH

PRELIMINARY: NOT FOR CONSTRUCTION

REV #	DESCRIPTION	DATE	CHECKED
02	ISSUED FOR HISTORIC RECORD	27/06/2019	AF
01	ISSUED FOR PROGRESS REVIEW	08/05/2019	AF

REVISIONS	
ISSUE DATA	DATE

SEAL:

PERMIT:

CONSULTANT: **gEC** architecture
 CONSULTANT PROJECT NO: 5719

PROJECT: **HANGAR 11 - BLATCHFORD
 ADVANCED ASSESSMENT
 & DOCUMENTATION**

BUILDING CODE:
 LOCATION: ADDRESS NW, EDMONTON, AB

DRAWING TITLE: **SECOND FLOOR PLAN**

SCALE: AS SHOWN ALL DIMENSION ARE IN MILLIMETRES
 DRAWN BY: Author Issue Date PROJECT NO: CP-####
 CHECKED BY: Checker Issue Date DRAWING NO: **A201**
 REVIEWED BY: Approver Issue Date

FILE NAME:

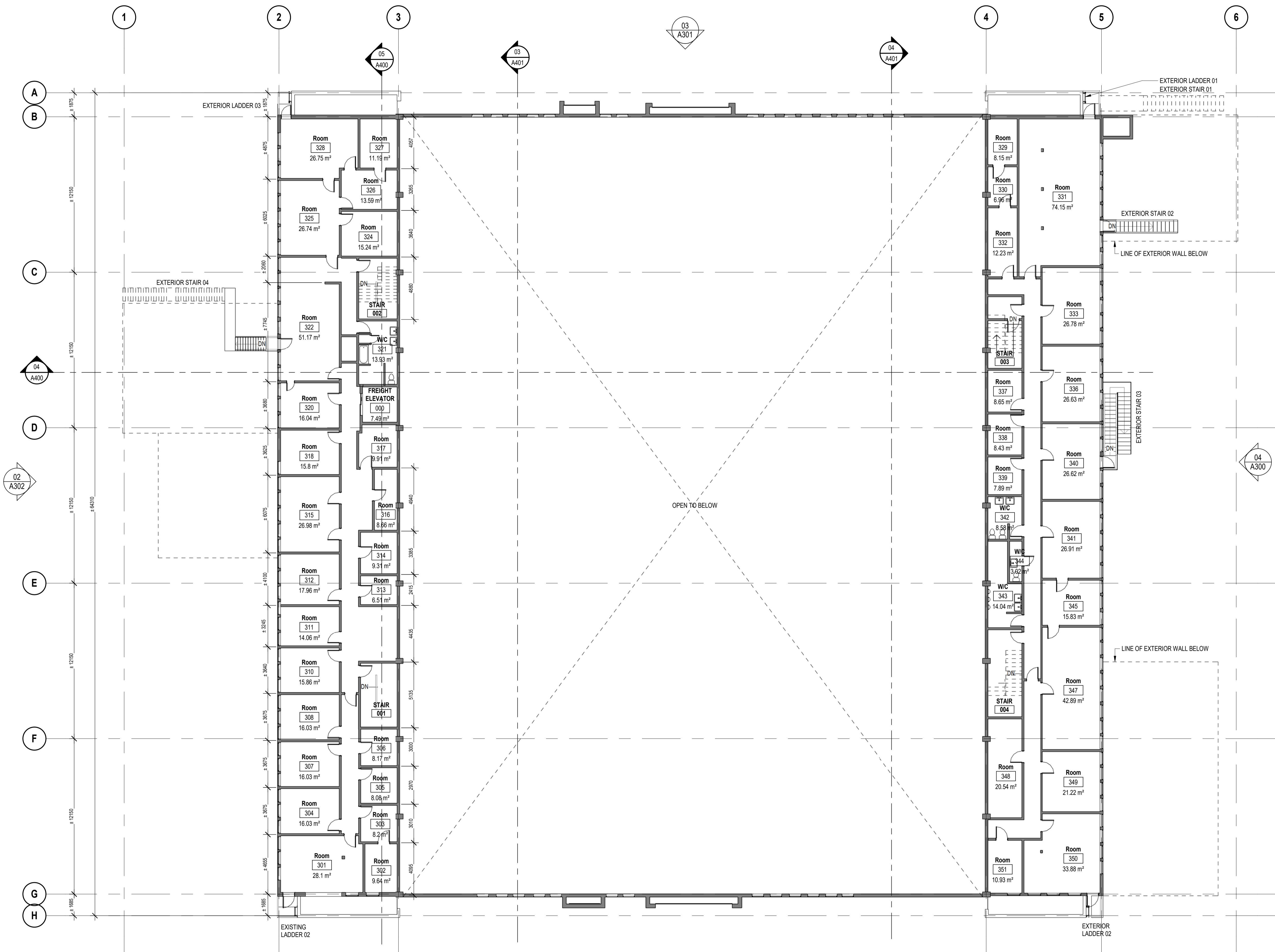

PRELIMINARY: NOT FOR CONSTRUCTION

REV #	DESCRIPTION	DATE	CHECKED
02	ISSUED FOR HISTORIC RECORD	27/06/2019	AF
01	ISSUED FOR PROGRESS REVIEW	08/05/2019	AF

REVISIONS	
ISSUE DATA	DATE

PERMIT:

CONSULTANT:

CONSULTANT PROJECT NO: 5719

PROJECT:

**HANGAR 11 - BLATCHFORD
ADVANCED ASSESSMENT
& DOCUMENTATION**

BUILDING CODE:

LOCATION: ADDRESS NW, EDMONTON, AB

DRAWING TITLE:

THIRD FLOOR PLAN

SCALE:	AS SHOWN ALL DIMENSION ARE IN MILLIMETRES
DRAWN BY:	Author
DATE:	Issue Date
CHECKED BY:	Checker
DATE:	Issue Date
REVIEWED BY:	Approver
DATE:	Issue Date

PROJECT NO: CP-####

DRAWING NO: **A202**



1 LEVEL 3 FLOOR PLAN
A202 Scale: 1 : 150

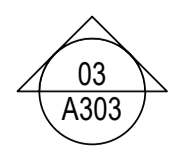

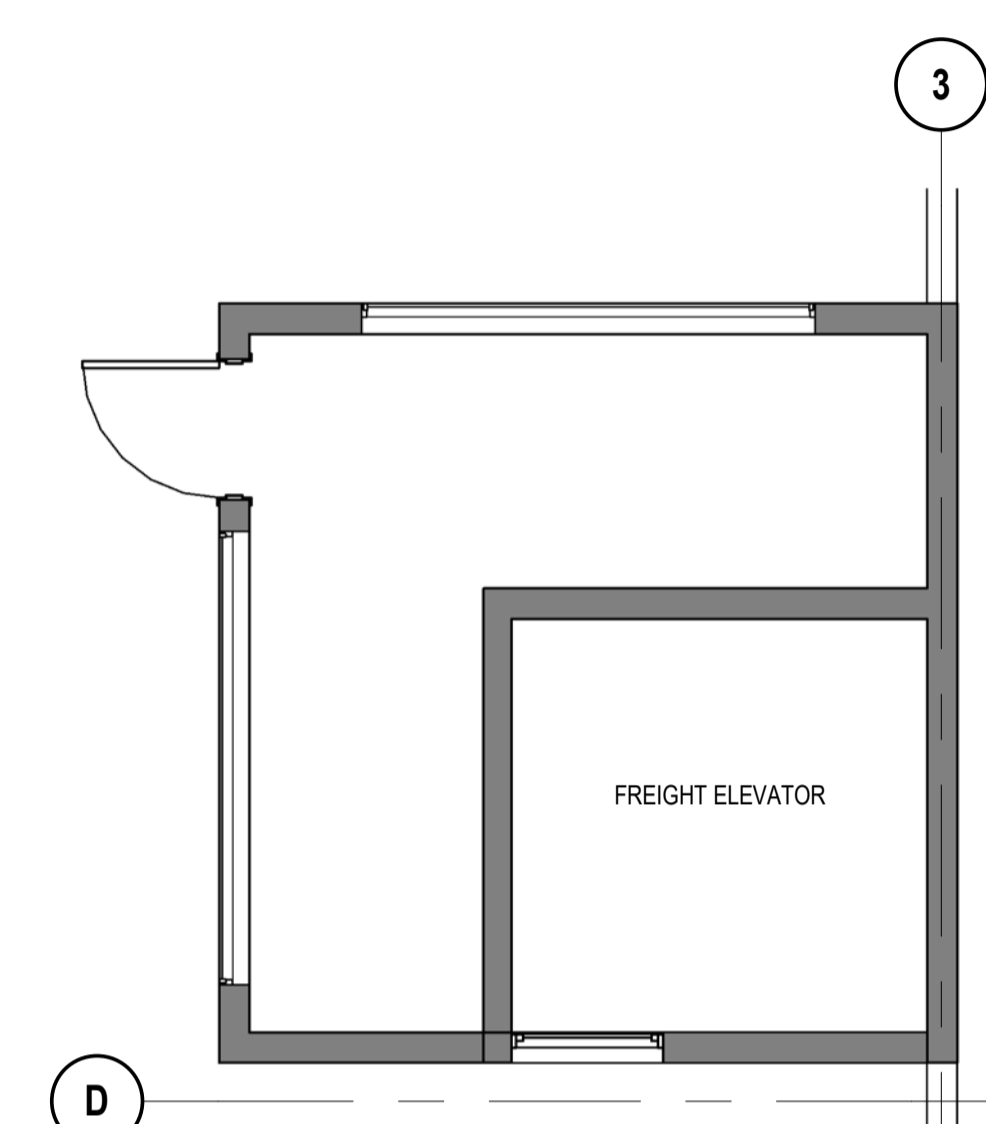
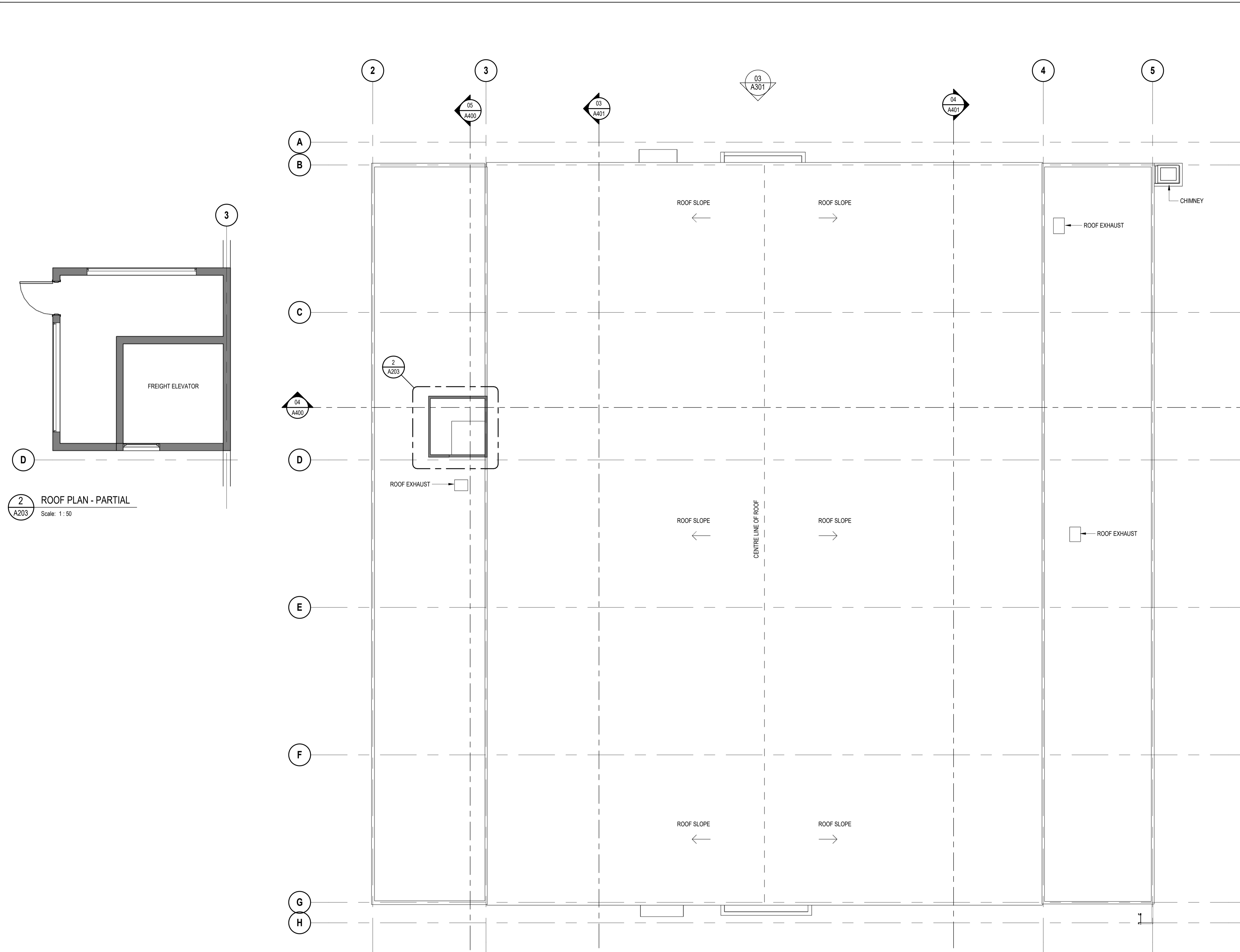

2 ROOF PLAN - PARTIAL
A203 Scale: 1:50

1 ROOF PLAN
A203 Scale: 1:150
PROJECT NORTH

PRELIMINARY: NOT FOR CONSTRUCTION

REVISIONS			
ISSUE DATA	DATE		

SEAL:	SEAL:

PERMIT:

CONSULTANT:

CONSULTANT PROJECT NO: 5719

INTEGRATED INFRASTRUCTURE SERVICES

PROJECT:
**HANGAR 11 - BLATCHFORD
ADVANCED ASSESSMENT
& DOCUMENTATION**

BUILDING CODE:
LOCATION: ADDRESS NW, EDMONTON, AB

DRAWING TITLE:
ROOF PLAN

SCALE: AS SHOWN ALL DIMENSION ARE IN MILLIMETRES	PROJECT NO: CP-####
DRAWN BY: Author DATE: Issue Date	DRAWING NO: A203
CHECKED BY: Checker DATE: Issue Date	
REVIEWED BY: Approver DATE: Issue Date	

FILE NAME:



01 IMAGE 01
A300 Scale: N.T.S.



02 IMAGE 02
A300 Scale: N.T.S.



03 IMAGE 03
A300 Scale: N.T.S.



04 IMAGE 04
A300 Scale: N.T.S.

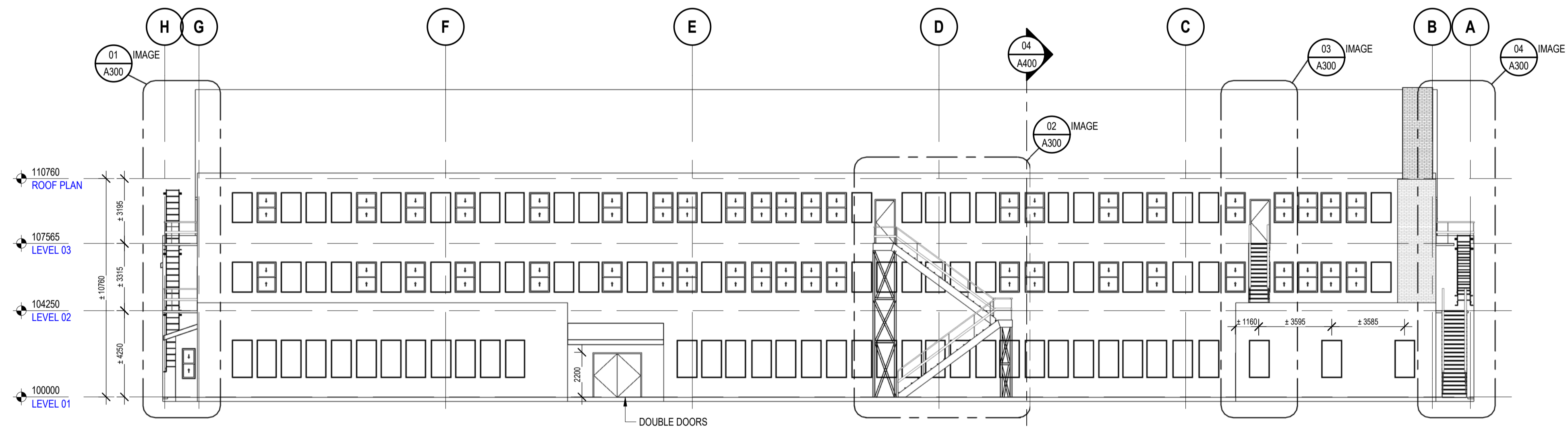

04 EAST ELEVATION
A300 Scale: 1:150

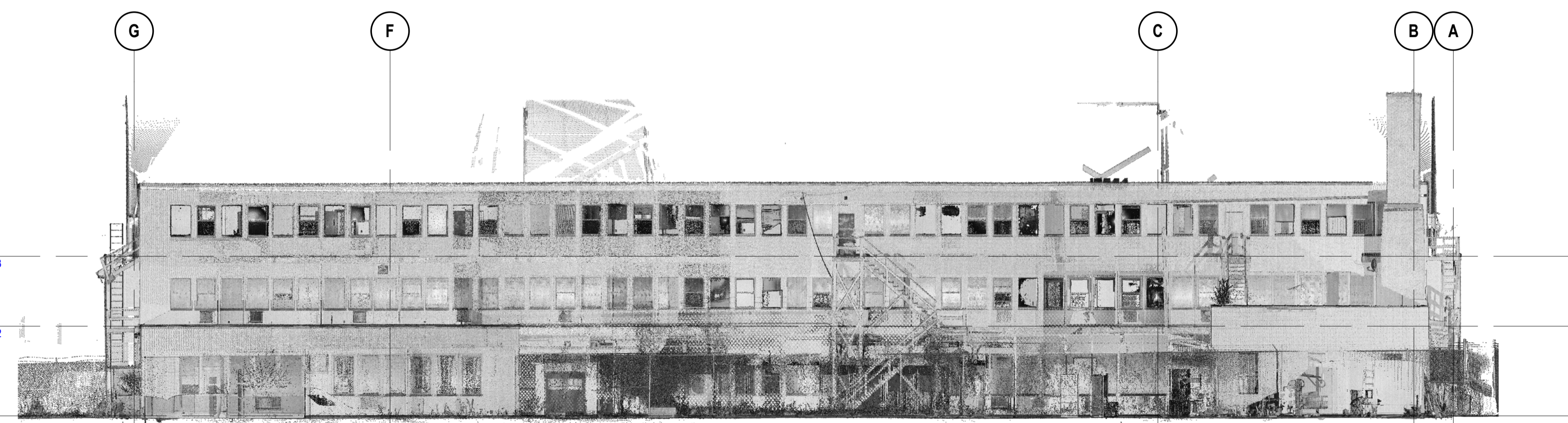
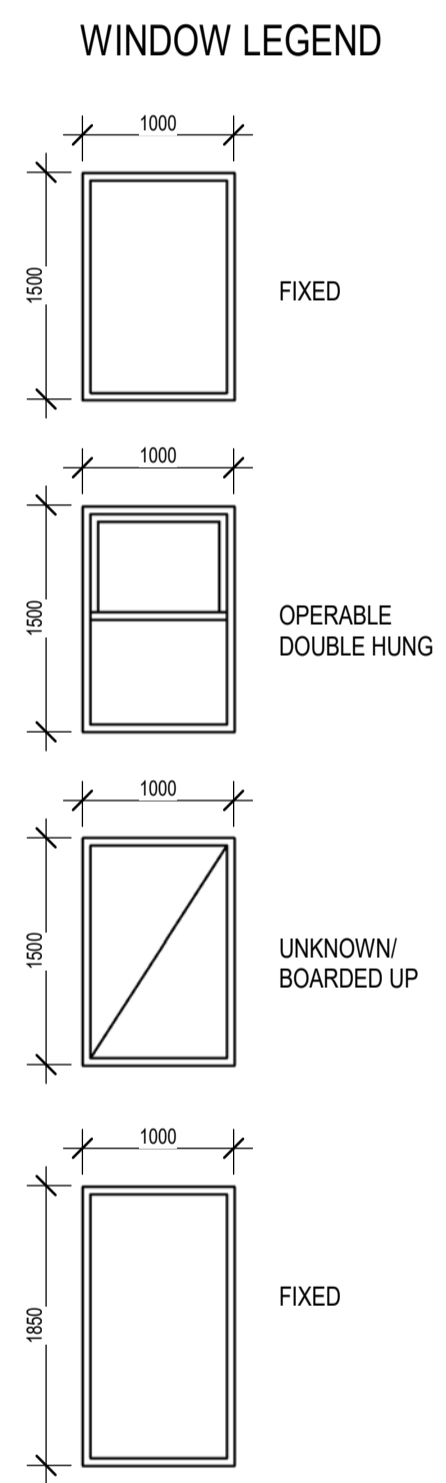

05 EAST ELEVATION - POINT CLOUD MODEL
A300 Scale: 1:150

PRELIMINARY: NOT FOR CONSTRUCTION

REV #	DESCRIPTION	DATE	CHECKED
02	ISSUED FOR HISTORIC RECORD	27/06/2019	AF
01	ISSUED FOR PROGRESS REVIEW	08/05/2019	AF

SEAL: SEAL:

PERMIT:

CONSULTANT: **gec** architecture
CONSULTANT PROJECT NO: 5719

THE CITY OF **Edmonton** INTEGRATED INFRASTRUCTURE SERVICES

PROJECT: **HANGAR 11 - BLATCHFORD
ADVANCED ASSESSMENT
& DOCUMENTATION**

BUILDING CODE:

LOCATION: ADDRESS NW, EDMONTON, AB

DRAWING TITLE: **EAST EXTERIOR
ELEVATION**

SCALE: AS SHOWN ALL DIMENSION ARE IN MILLIMETRES	PROJECT NO: CP-####
DRAWN BY: Author DATE: Issue Date	DRAWING NO: A300
CHECKED BY: Checker DATE: Issue Date	
REVIEWED BY: Approver DATE: Issue Date	

FILE NAME:



01 IMAGE 05
A301 Scale: N.T.S.



02 IMAGE 06
A301 Scale: N.T.S.

WINDOW LEGEND

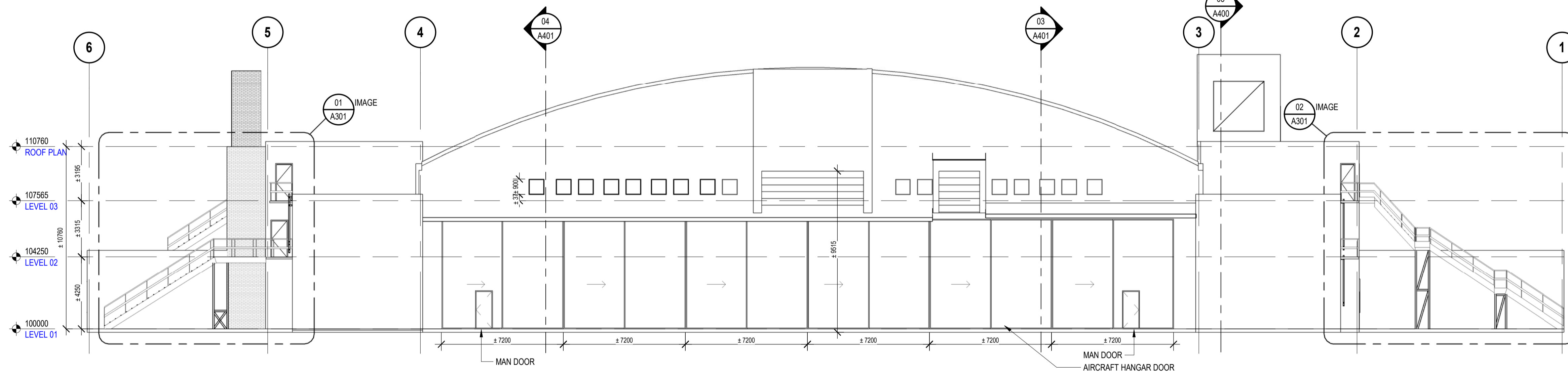
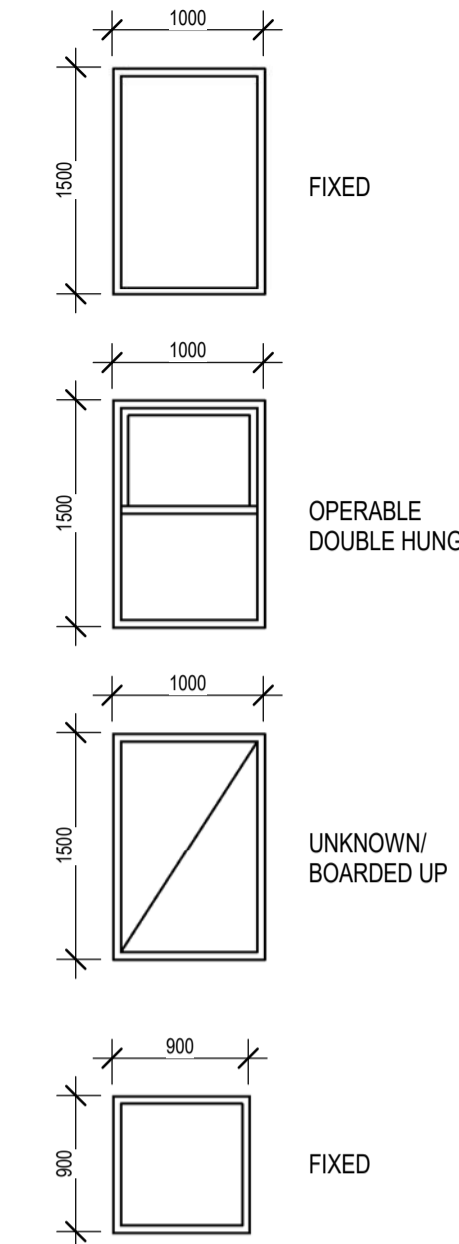

03 NORTH ELEVATION
A301 Scale: 1:150

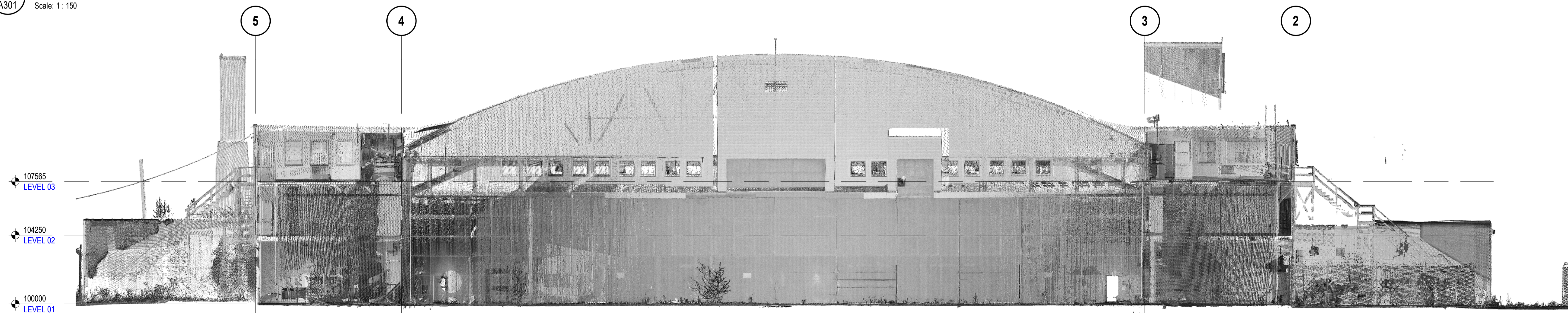

04 NORTH ELEVATION - POINT CLOUD MODEL
A301 Scale: 1:150

PRELIMINARY: NOT FOR CONSTRUCTION

REV #	DESCRIPTION	DATE	CHECKED
02	ISSUED FOR HISTORIC RECORD	27/06/2019	AF
01	ISSUED FOR PROGRESS REVIEW	08/05/2019	AF

REVISIONS	
ISSUE DATA	DATE

SEAL:	SEAL:
-------	-------

CONSULTANT:

CONSULTANT PROJECT NO: 5719

THE CITY OF
Edmonton INTEGRATED INFRASTRUCTURE SERVICES

PROJECT:

**HANGAR 11 - BLATCHFORD
ADVANCED ASSESSMENT
& DOCUMENTATION**

BUILDING CODE:

LOCATION: ADDRESS NW, EDMONTON, AB

DRAWING TITLE:

**NORTH EXTERIOR
ELEVATION**

SCALE: AS SHOWN ALL DIMENSION ARE IN MILLIMETRES

DRAWN BY: Author	PROJECT NO: CP-####
DATE: Issue Date	
CHECKED BY: Checker	DRAWING NO: A301
DATE: Issue Date	
REVIEWED BY: Approver	
DATE: Issue Date	

FILE NAME:



01 IMAGE 07
A302 Scale: N.T.S.

WINDOW LEGEND

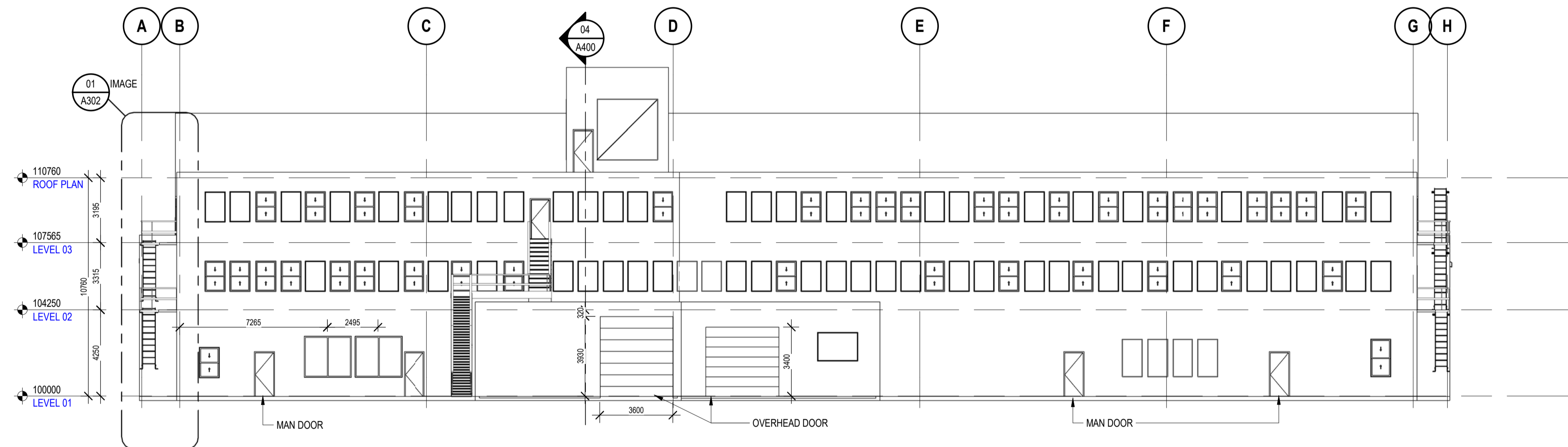
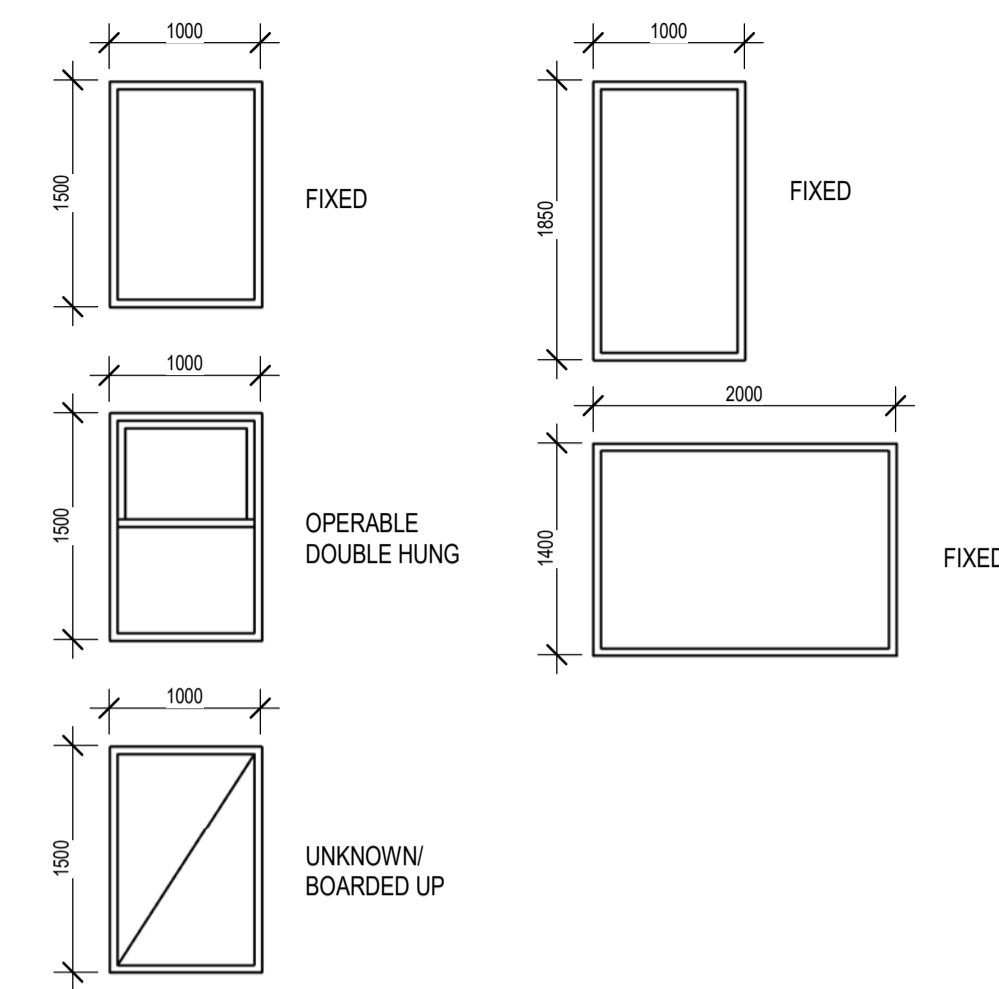

02 WEST ELEVATION
A302 Scale: 1 : 150

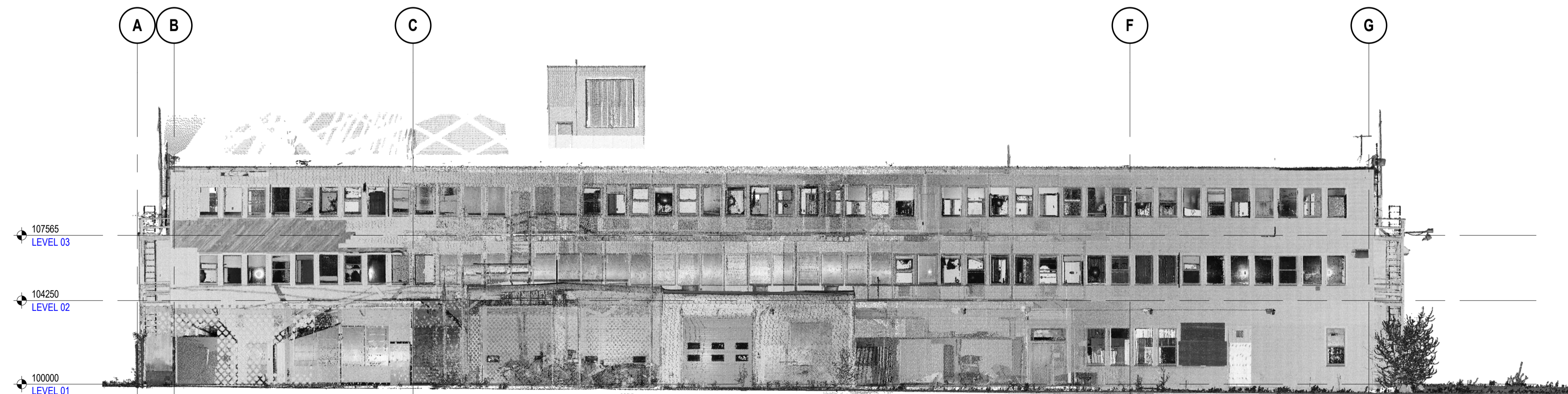

03 WEST ELEVATION - POINT CLOUD MODEL
A302 Scale: 1 : 150

PRELIMINARY: NOT FOR CONSTRUCTION

REV #	DESCRIPTION	DATE	CHECKED
02	ISSUED FOR HISTORIC RECORD	27/06/2019	AF
01	ISSUED FOR PROGRESS REVIEW	08/05/2019	AF

REVISIONS	
ISSUE DATA	DATE

PERMIT:

CONSULTANT:

CONSULTANT PROJECT NO: 5719

THE CITY OF
Edmonton INTEGRATED INFRASTRUCTURE SERVICES

PROJECT:
**HANGAR 11 - BLATCHFORD
ADVANCED ASSESSMENT
& DOCUMENTATION**

BUILDING CODE:

LOCATION: ADDRESS NW, EDMONTON, AB

DRAWING TITLE:
**WEST EXTERIOR
ELEVATION**

SCALE: AS SHOWN ALL DIMENSION ARE IN MILLIMETRES	PROJECT NO: CP-####
DRAWN BY: Author DATE: Issue Date	DRAWING NO: A302
CHECKED BY: Checker DATE: Issue Date	
REVIEWED BY: Approver DATE: Issue Date	

FILE NAME:



01 IMAGE 08
A303 Scale: N.T.S.



02 IMAGE 09
A303 Scale: N.T.S.



03 IMAGE 10
A303 Scale: N.T.S.

WINDOW LEGEND

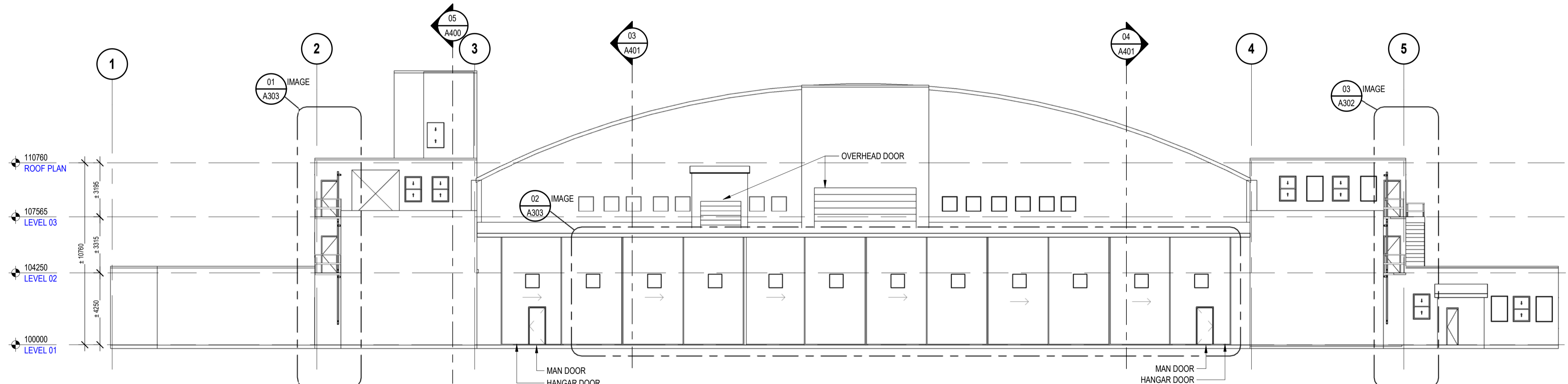
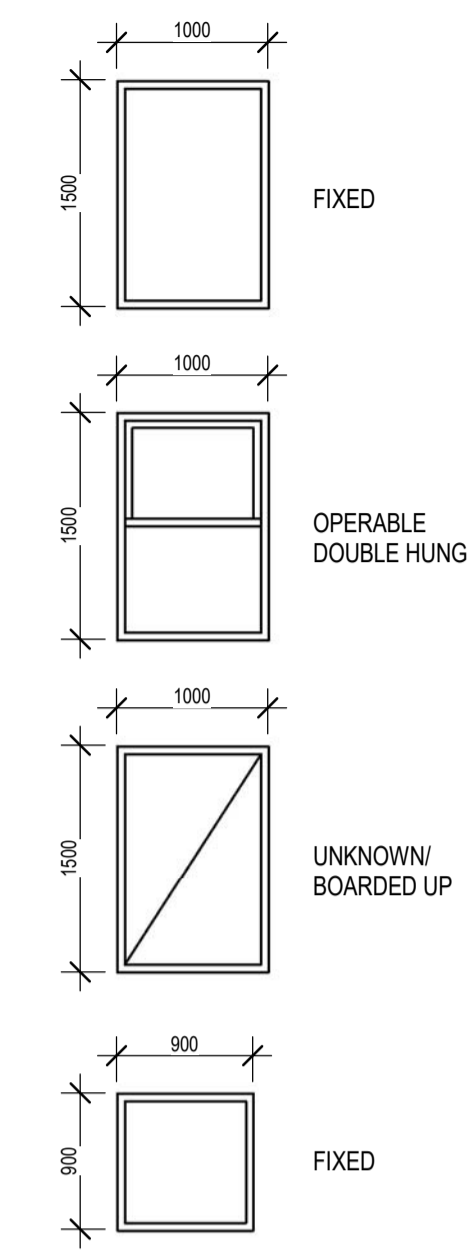

03 SOUTH ELEVATION
A303 Scale: 1:150

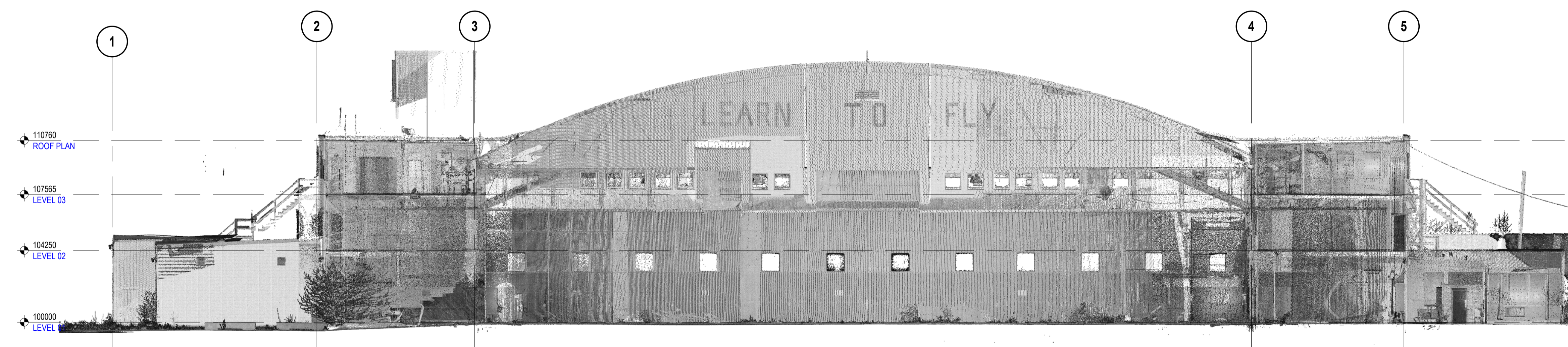

04 ELEVATION - SOUTH POINT CLOUD
A303 Scale: 1:150

PRELIMINARY: NOT FOR CONSTRUCTION

REV #	DESCRIPTION	DATE	CHECKED
02	ISSUED FOR HISTORIC RECORD	27/06/2019	AF
01	ISSUED FOR PROGRESS REVIEW	08/05/2019	AF

REVISIONS	
ISSUE DATA	DATE

PERMIT: _____

CONSULTANT: **gec** architecture
CONSULTANT PROJECT NO: 5719

THE CITY OF **Edmonton** INTEGRATED INFRASTRUCTURE SERVICES

PROJECT: **HANGAR 11 - BLATCHFORD
ADVANCED ASSESSMENT
& DOCUMENTATION**

BUILDING CODE: _____
LOCATION: ADDRESS NW, EDMONTON, AB

DRAWING TITLE: **SOUTH EXTERIOR
ELEVATION**

SCALE: AS SHOWN ALL DIMENSION ARE IN MILLIMETRES	PROJECT NO: CP-####
DRAWN BY: Author DATE: Issue Date	DRAWING NO: A303
CHECKED BY: Checker DATE: Issue Date	
REVIEWED BY: Approver DATE: Issue Date	

FILE NAME: _____

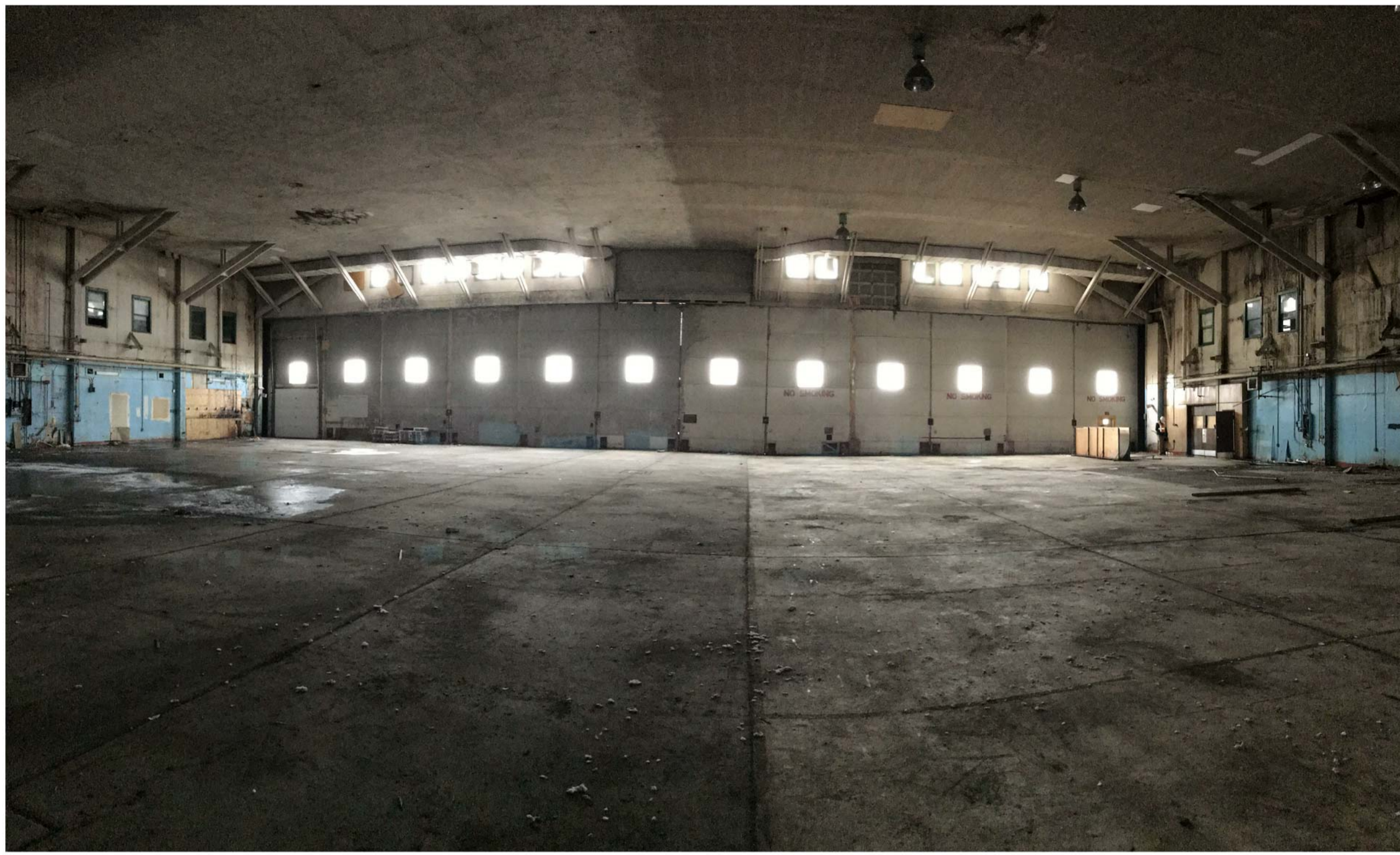

01 IMAGE 09
A400 Scale: N.T.S.

02 IMAGE 10
A400 Scale: N.T.S.



03 IMAGE 11
A400 Scale: N.T.S.

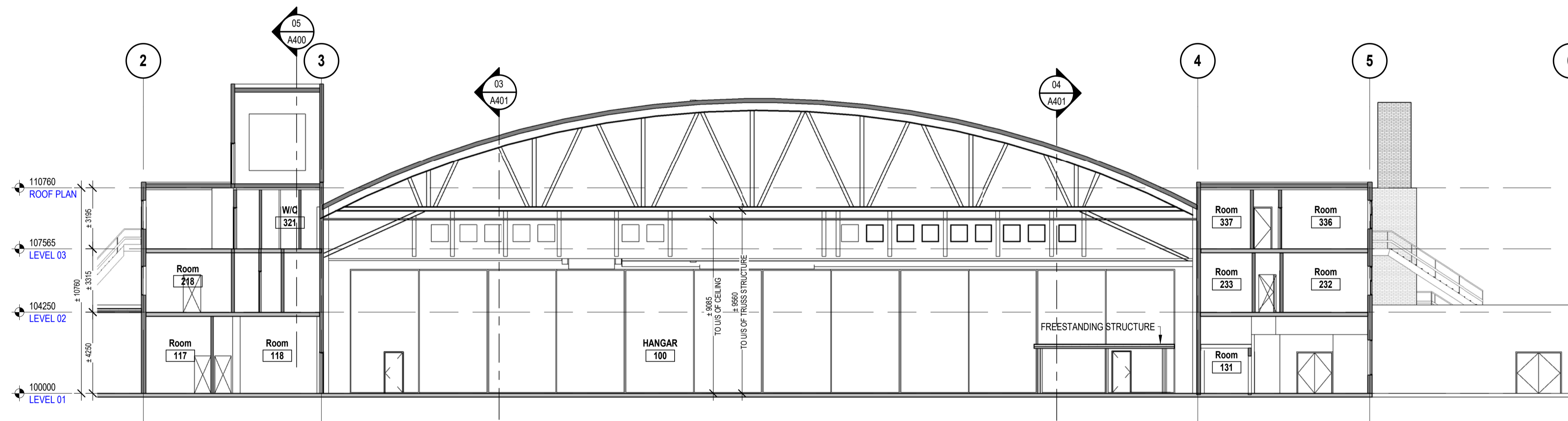

04 WEST TO EAST HANGAR BUILDING SECTION
A400 Scale: 1:150

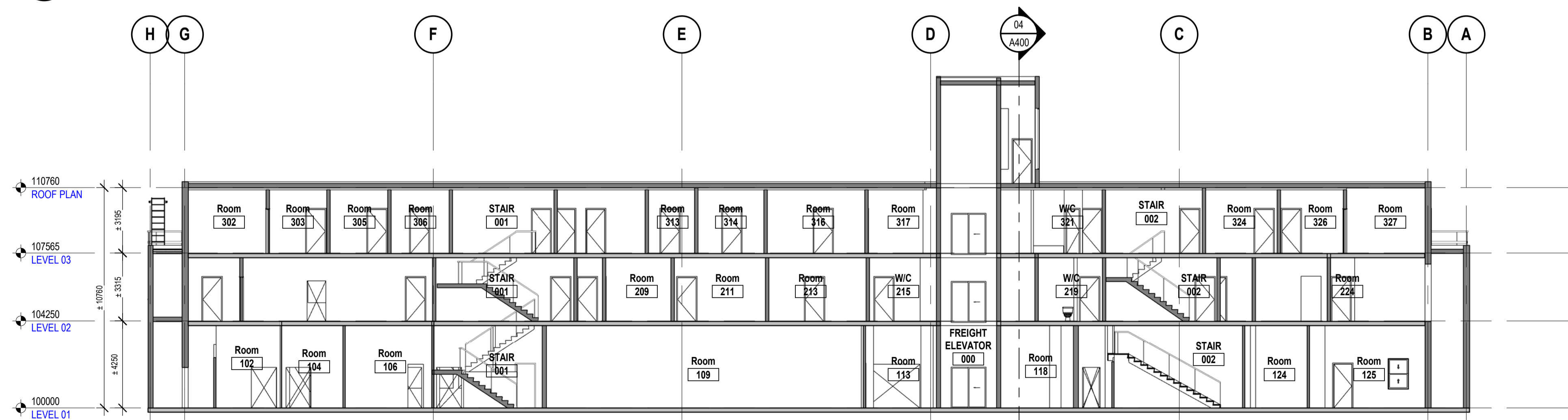

05 OFFICE / STAIR BUILDING SECTION
A400 Scale: 1:150

PRELIMINARY: NOT FOR CONSTRUCTION

REV #	DESCRIPTION	DATE	CHECKED
02	ISSUED FOR HISTORIC RECORD	27/06/2019	AF
01	ISSUED FOR PROGRESS REVIEW	08/05/2019	AF

REVISIONS	
ISSUE DATA	DATE

SEAL: SEAL:

CONSULTANT: **gec** architecture
CONSULTANT PROJECT NO: 5719

Edmonton INTEGRATED INFRASTRUCTURE SERVICES

PROJECT: **HANGAR 11 - BLATCHFORD
ADVANCED ASSESSMENT
& DOCUMENTATION**

BUILDING CODE:
LOCATION: ADDRESS NW, EDMONTON, AB

DRAWING TITLE: **BUILDING SECTIONS**

SCALE: AS SHOWN ALL DIMENSION ARE IN MILLIMETRES

DRAWN BY: Author	PROJECT NO: CP-####
DATE: Issue Date	
CHECKED BY: Checker	DRAWING NO: A400
DATE: Issue Date	
REVIEWED BY: Approver	
DATE: Issue Date	

FILE NAME: _____

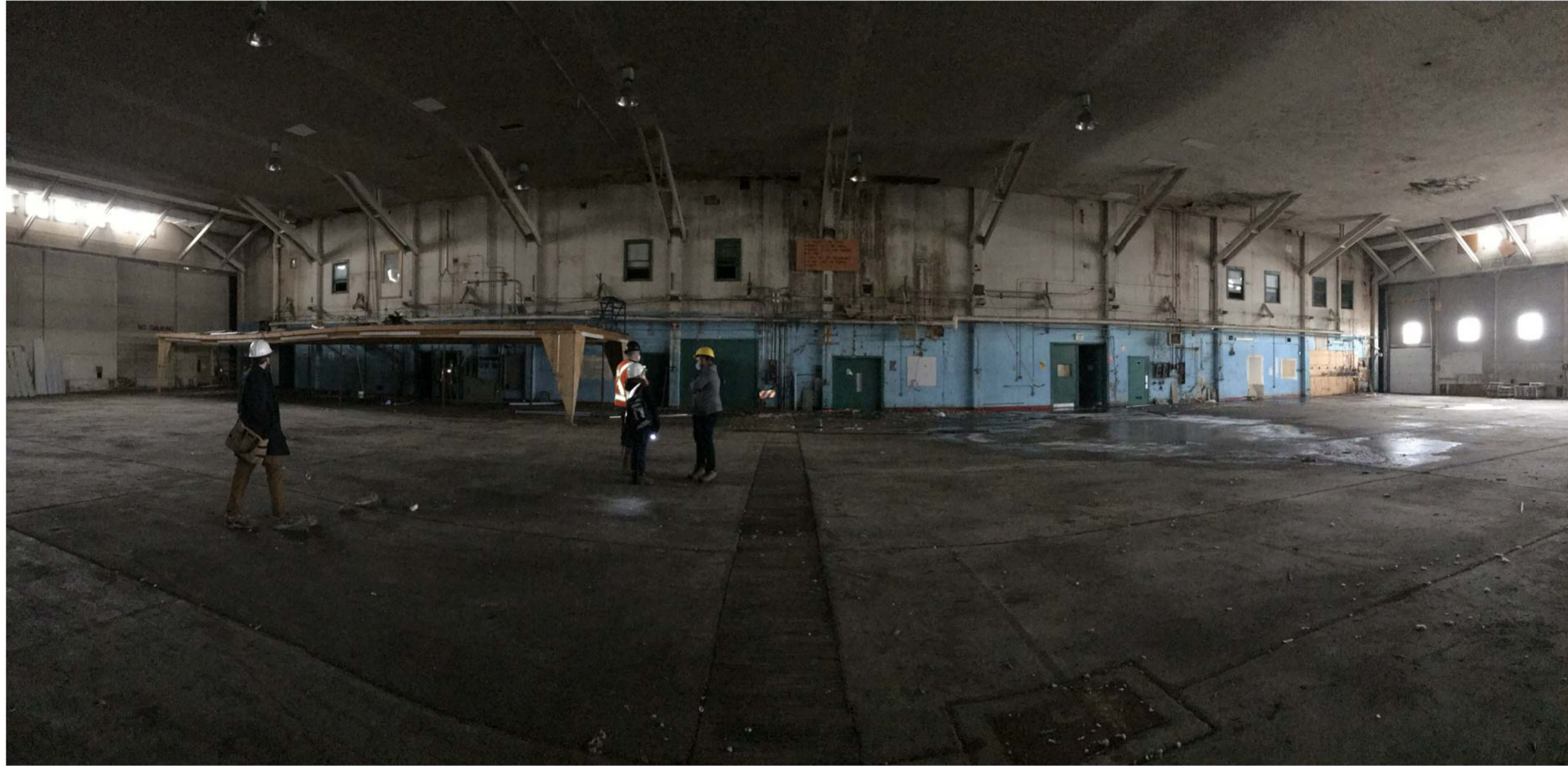

01 IMAGE 12
A401 Scale: N.T.S.

02 IMAGE 13
A401 Scale: N.T.S.

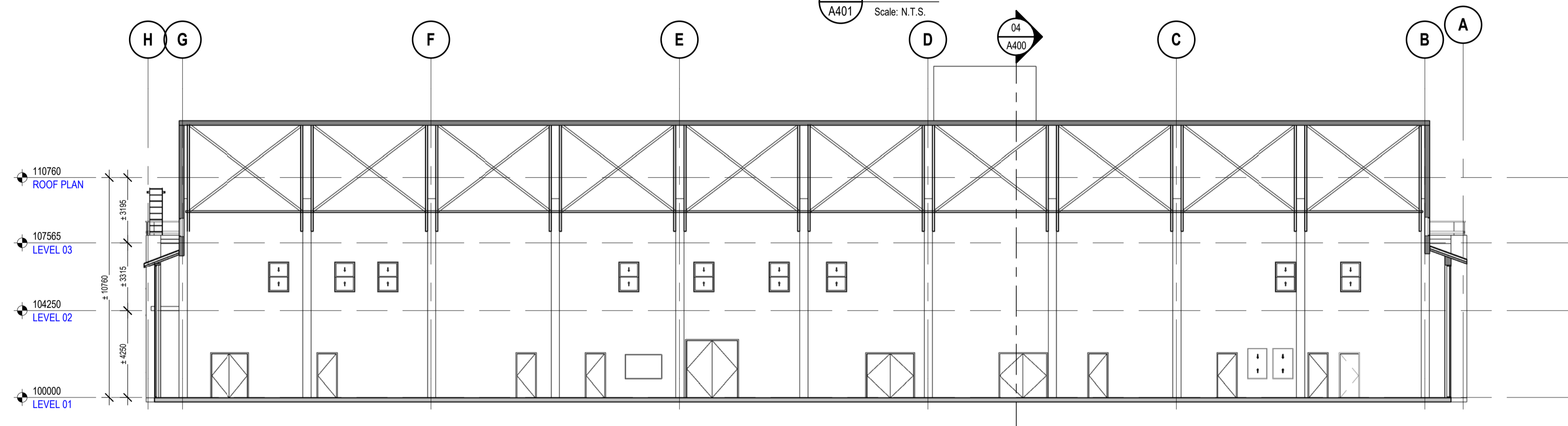

03 NORTH TO SOUTH HANGAR BUILDING SECTION
A401 Scale: 1:150

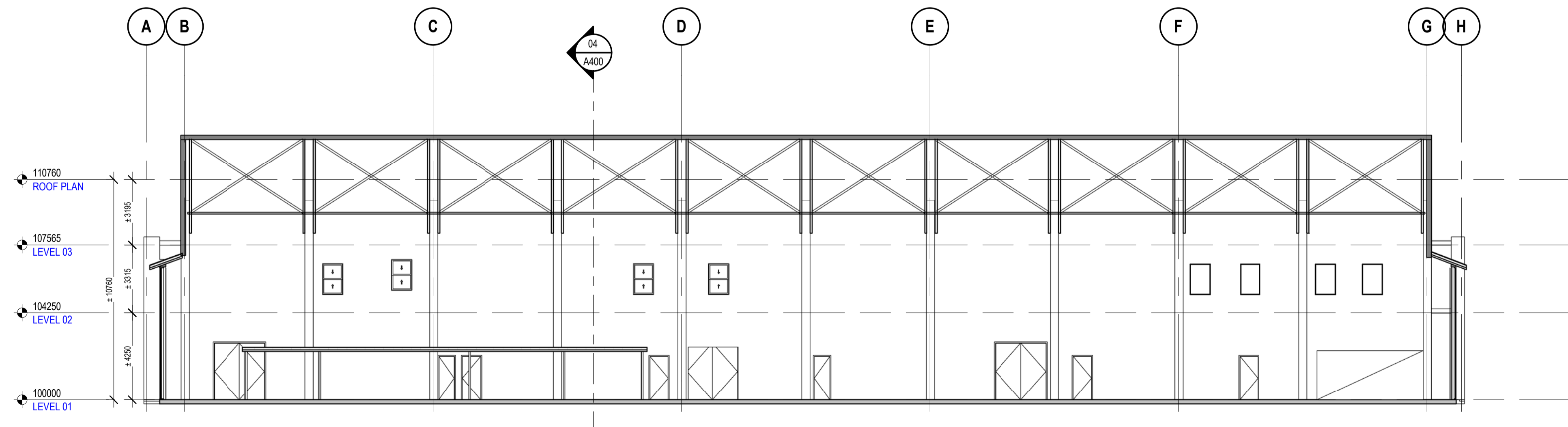

04 NORTH TO SOUTH HANGAR BUILDING SECTION 2
A401 Scale: 1:150

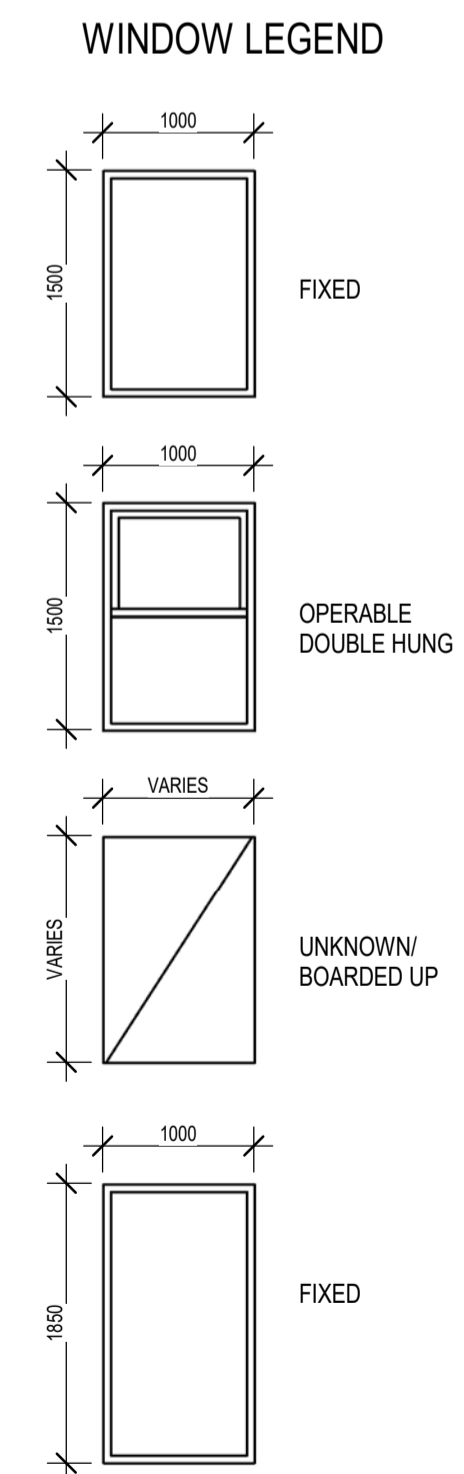

PRELIMINARY: NOT FOR CONSTRUCTION

REVISIONS			
REV #	DESCRIPTION	DATE	CHECKED
02	ISSUED FOR HISTORIC RECORD	27/06/2019	AF
01	ISSUED FOR PROGRESS REVIEW	08/05/2019	AF

SEAL:	SEAL:

PERMIT:

CONSULTANT:

CONSULTANT PROJECT NO: 5719

PROJECT:
**HANGAR 11 - BLATCHFORD
ADVANCED ASSESSMENT
& DOCUMENTATION**

BUILDING CODE:

LOCATION: ADDRESS NW, EDMONTON, AB

DRAWING TITLE:
**HANGAR BUILDING
SECTIONS**

SCALE: AS SHOWN ALL DIMENSION ARE IN MILLIMETRES	PROJECT NO: CP-####
DRAWN BY: Author DATE: Issue Date	DRAWING NO: A401
CHECKED BY: Checker DATE: Issue Date	
REVIEWED BY: Approver DATE: Issue Date	

FILE NAME:

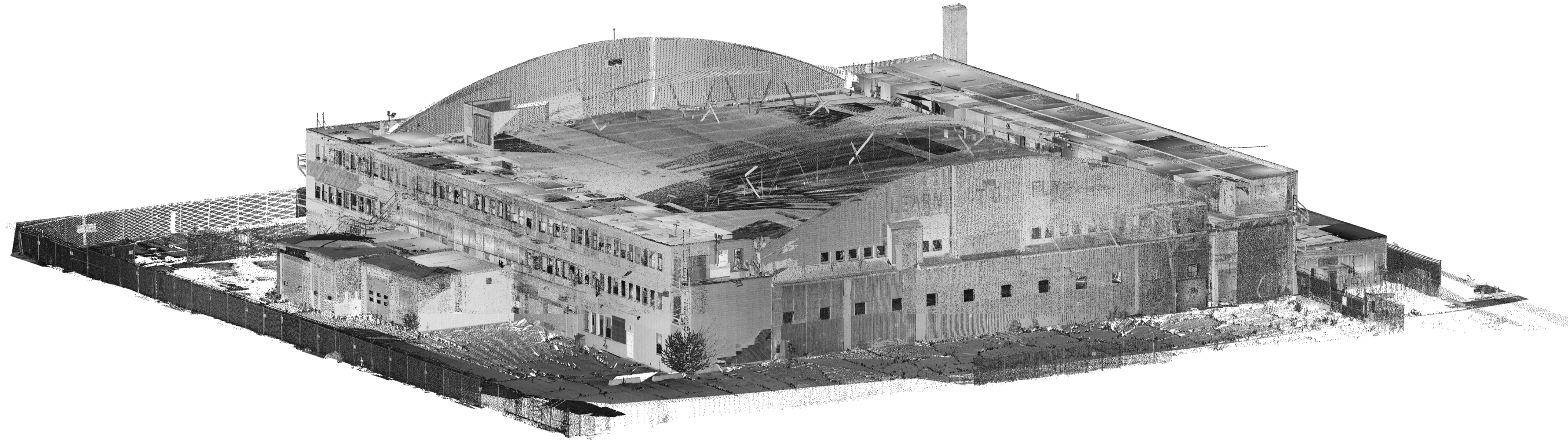

1 SOUTH WEST CORNER AXONOMETRIC VIEW
A501 Scale:

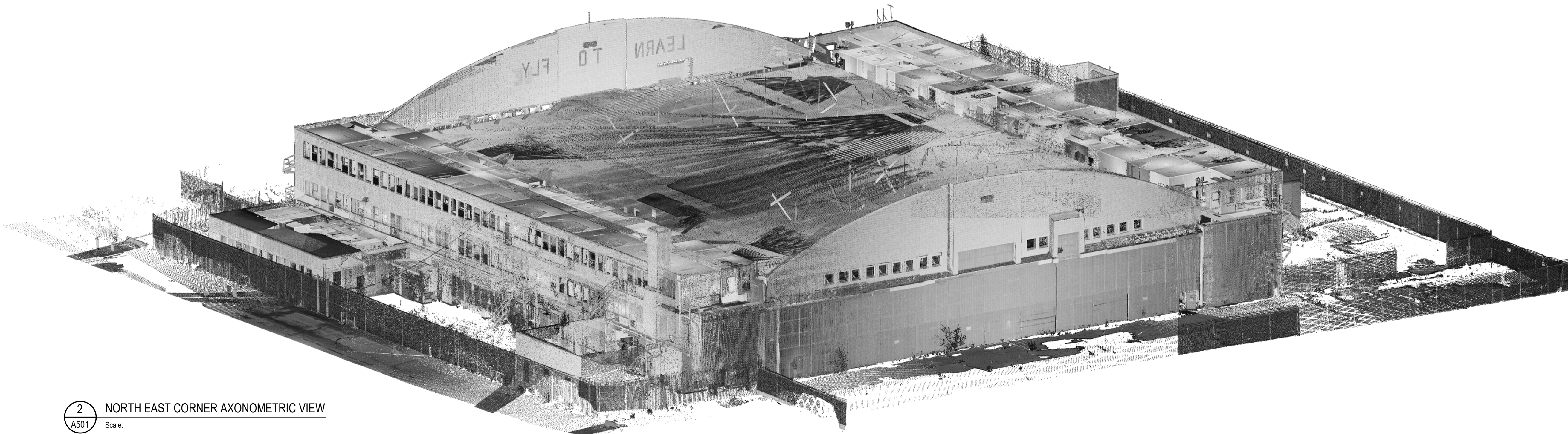

2 NORTH EAST CORNER AXONOMETRIC VIEW
A501 Scale:

PRELIMINARY: NOT FOR CONSTRUCTION

REV #	DESCRIPTION	DATE	CHECKED
02	ISSUED FOR HISTORIC RECORD	27/06/2019	AF
01	ISSUED FOR PROGRESS REVIEW	08/05/2019	AF

REVISIONS	
ISSUE DATA	DATE

PERMIT:

CONSULTANT:



CONSULTANT PROJECT NO: 5719

THE CITY OF
Edmonton INTEGRATED INFRASTRUCTURE SERVICES

PROJECT:
**HANGAR 11 - BLATCHFORD
ADVANCED ASSESSMENT
& DOCUMENTATION**

BUILDING CODE:

LOCATION: ADDRESS NW, EDMONTON, AB

DRAWING TITLE:
**POINT CLOUD
AXONOMETRIC
BUILDING IMAGES**

SCALE: AS SHOWN ALL DIMENSION ARE IN MILLIMETRES	PROJECT NO: CP-####
DRAWN BY: Author DATE: Issue Date	DRAWING NO: A501
CHECKED BY: Checker DATE: Issue Date	
REVIEWED BY: Approver DATE: Issue Date	
FILE NAME:	

**CITY OF EDMONTON - HANGAR 11
CONSERVATION PLAN
EDMONTON, ALBERTA**

CLASS D ESTIMATE

**Prepared for:
City of Edmonton c/o GEC Architecture**

**June 17, 2019
Updated October 22, 2019**



June 17, 2019

Ref # E2424

City of Edmonton c/o GEC Architecture
10345 105 St NW
Edmonton, Alberta T5J 1E8
T: (780) 421-8060
E: Alexis.Finlay@gecarchitecture.com

Attn: Alexis Finlay, B.F.A., M.Arch., Architect, AAA, LEED® AP

Re: City of Edmonton - Hangar 11, Conservation Plan, Edmonton, Alberta

Dear Ms. Finlay:

Please find attached our Class D Estimate for the City of Edmonton - Hangar 11, Conservation Plan in Edmonton, Alberta.

This Class D Estimate is intended to provide a realistic allocation of direct construction costs and is a determination of fair market value. Pricing shown reflects probable construction costs obtainable in the Edmonton, Alberta area on the effective date of this report and is not a prediction of low bid. Pricing assumes competitive bidding for every portion of the work.

Hanscomb has prepared this estimate in accordance with generally accepted principles and practices. Our general assumptions are included in Section 3 of this report and any exclusions are identified in Section 1.6. For quality assurance, this estimate has been reviewed by the designated Team Lead as signed below and Hanscomb staff are available and pleased to discuss the contents of this report with any interested party.

Requests for modifications of any apparent errors or omissions to this document must be made to Hanscomb within ten (10) days of receipt of this estimate. Otherwise, it will be understood that the contents have been concurred with and accepted.

We trust our estimate is complete and comprehensive and provides the necessary information to allow for informed capital decisions for moving this project forward. Please do not hesitate to contact us if you have any questions or require additional information.

Yours truly,

Hanscomb Limited
Team Lead



Alfredo Motta
CET, CEC
Cost Consultant

Hanscomb Limited
Principal / Estimate Reviewer



Mike Swick
PQS, MRICS
Director

Hanscomb
Quantity Surveyors - Since 1957



Hanscomb Limited
503 - 10080 Jasper Ave.
Edmonton, Alberta T5J 1V9
T: (780) 426-7980
edmonton@hanscomb.com
www.hanscomb.com

TABLE OF CONTENTS

1. Introduction	2
1.1 Purpose	2
1.2 Description	2
1.3 Methodology	2
1.4 Specifications	2
1.5 Estimate Classification and Cost Predictability	3
1.6 Exclusions	4
2. Documentation	5
3. Cost Considerations	6
3.1 Cost Base	6
3.2 Unit Rates	6
3.3 General Requirements and Fee	6
3.4 Design and Pricing Allowance	6
3.5 Escalation Allowance	6
3.6 Construction Allowance	7
3.7 Taxes	7
3.8 Schedule	7
3.9 Statement of Probable Costs	7
3.10 Ongoing Cost Control	8
4. Gross Floor Areas	9
5. Cost Estimate Summary	10

Appendices

Estimates:

- A - Detailed Elemental Estimate- Stabilization
- B - Detailed Elemental Estimate- Conservation

Documents and Drawings:

- AA - Documents and Representative Drawings

1. INTRODUCTION

1.1 PURPOSE

This Class D Estimate is intended to provide a realistic allocation of direct construction costs for the City of Edmonton - Hangar 11, Conservation Plan, located in Edmonton, Alberta, with the exception of the items listed in 1.6 Exclusions.

1.2 DESCRIPTION

The City of Edmonton - Hangar 11, Conservation Plan located in Edmonton, Alberta is comprised of the following key elements:

Stabilization: *The project includes the Stabilization plan for the existing hangar 11 building on the City Centre Municipal Airport of Edmonton. The building's exterior wall, roof and floor structures would be repaired and upgraded as indicated on drawings and list on drawing C0.1 provided by Heritage E.R.A Architects. Structural stabilization costs are based on section 5.1 of the RJC Structural Assessment report referenced in section 2 of this report*

Conservation: *The project includes the conservation plan for the existing hangar 11 building on the City Centre Municipal Airport of Edmonton. The building's exterior wall, roof and floor structures would be repaired and upgraded as indicated on drawings and list on drawing C0.1 provided by Heritage E.R.A Architects. CP-19 Hangar Doors option 2 costs is provided for information purposes on appendix C. Structural conservation costs are based on section 5.2 of the RJC Structural Assessment report referenced in section 2 of this report*

1.3 METHODOLOGY

Hanscomb has prepared this estimate(s) in accordance with generally accepted principles and practices. Hanscomb staff are available to discuss its contents with any interested party.

From the documentation and information provided, quantities of all major elements were assessed or measured where possible and priced at rates considered competitive for a project of this type under a stipulated sum form of contract in Edmonton, Alberta.

Pricing shown reflects probable construction costs obtainable in the Edmonton, Alberta area on the effective date of this report. This estimate is a determination of fair market value for the construction of this project. It is not a prediction of low bid. Pricing assumes competitive bidding for every portion of the work.

1.4 SPECIFICATIONS

For building components and systems where specifications and design details are not available, quality standards have been established based on discussions with the design team.

1. INTRODUCTION

1.5 ESTIMATE CLASSIFICATION AND COST PREDICTABILITY

Estimates are defined and classified based on the stage of a project's development and the level of information available at the time of the milestone estimate.

This Class D Estimate is considered to have an expected degree of accuracy of +/- 50-50%. In other words, bid results might vary by this amount if the construction budget were set at this milestone estimate.

At the initial stages of a contemplated project, the cost accuracy of the estimate is low as there may be little or no information available to inform a first high-level concept estimate or order of magnitude estimate. As a project nears design completion and is ready to be released to market for tender, the level of accuracy of the estimate is high as the detail is generally extensive and typically represents the information on which contractors will bid.

Milestone cost estimates or "checks" are recommended as the project design develops to keep track of scope and budget. Early detection of potential budget overruns will allow for remedial action before design and scope are locked in. The number of milestone estimates will depend on a project's size and schedule and cost predictability will improve as the design advances.

According to the Canadian Joint Federal Government/Industry Cost Predictability Taskforce, industry standards for estimate classification and cost estimate accuracy may be summarized as follows:

COST ESTIMATE CLASSIFICATION SYSTEM						
AACE	Class 5	Class 4	Class 3		Class 2	Class 1
DND			Indicative		Substantive	
RAIC	OME	Sketch Design	Design Develop		Contract Documents	Tender Documents
GOC	OME	D	C	← B →		A

Legend

AACE	Association for the Advancement of Cost Engineering
DND	Department of National Defence
GOC	Government of Canada
RAIC	Royal Architectural Institute of Canada
OME	Order of Magnitude Estimate

While the classification categories differ from one authority to the next, the overarching principle for cost predictability remains the same – as the level of detail and design development increases, so does the level of accuracy of the estimate.

1. INTRODUCTION

1.6 EXCLUSIONS

This Class D Estimate does not provide for the following, if required:

- Site Remediation
- Site Development
- New water services
- Removal of any underground tanks
- Equipment beyond that identified in this estimate
- Loose furniture, furnishings and equipment
- Special audio, visual, security equipment or installation other than provision of empty conduit systems carried in electrical division
- Window treatments
- Winter Construction (Concrete foundation and masonry heating & hoarding)
- Value-added tax (e.g. Goods and Services Tax, Harmonized Sales Tax, or other)
- Premiums associated with Public-Private Partnership procurement model
- Soft Costs (Note We have provided summary level Soft Cost excluding the following)
 - Building permit
 - Development charges
 - Easement costs
 - Financing costs
 - Fund raising costs
 - Land acquisition costs and impost charges
 - Legal fees and expenses
 - Preventative maintenance contracts
 - Right of way charges
 - Value-added tax (e.g. Harmonized Sales Tax, Goods and Services Tax, or other)

2. DOCUMENTATION

This Class D Estimate has been prepared from the documentation included in Appendix AA of this report.

All of the above documentation was received from GEC Architecture and was supplemented with information gathered in meeting(s) and telephone conversations with the design team, as applicable.

Design changes and/or additions made subsequent to this issuance of the documentation noted above have not been incorporated in this report.

Note: September update is based upon the information provided in the Structural Assessment Report dated August 12, 2019, prepared by Read Jones Christoffersen (RJC) and supplemented with clarifications gathered in meeting(s) with RJC.

3. COST CONSIDERATIONS

3.1 COST BASE

All costs are estimated on the basis of competitive bids (a minimum of at least 4 subcontractor bids for each trade) being received in June 2019 from a Construction Manager and all major subcontractors and suppliers based on a stipulated sum form of sub-contract. If these conditions are not met, bids received could be expected to exceed this estimate.

3.2 UNIT RATES

The unit rates in the preparation of this Class D Estimate include labour and material, equipment, subcontractor's overheads and profit. Union contractors are assumed to perform the work with the fair wage policy in effect.

3.3 GENERAL REQUIREMENTS AND FEE

General Requirements and Fee cover the General Contractor's indirect costs which may include but not be limited to supervision, site set up, temporary utilities, equipment, utilities, clean up, etc. as covered in Division 1 General Conditions of the Contract Documents. It also includes the contractor's fees and should not be confused with Design or Consultant fees which are excluded from the Construction Costs and carried separately in the Owner's Total Project Costs.

3.4 DESIGN AND PRICING ALLOWANCE

An allowance of 20% has been included to cover design and pricing unknowns. This allowance is not intended to cover any program space modifications but rather to provide some flexibility for the designers and cost planners during the remaining contract document stages.

It is expected that this allowance amount will be absorbed into the base construction costs as the design advances. The amount by which this allowance is reduced corresponds to an increase in accuracy and detailed design information. Hanscomb recommends that careful consideration be made at each milestone estimate to maintain adequate contingency for this allowance.

As a project nears completion of design, Hanscomb recommends retaining some contingency for this allowance for the final coordination of documents.

3.5 ESCALATION ALLOWANCE

All costs are based on June 2019 dollars. An allowance 1.5% per annum has been made for construction cost escalation that may occur between June 2019 and the anticipated bid date of 2nd quarter 2021 for the project. Escalation during construction is included in the unit rates.

For escalation, the budgeted amount will typically decline as the time to award nears. Forecasting escalation requires careful assessment of a continually changing construction market which at best is difficult to predict. The escalation rate should be monitored.

3. COST CONSIDERATIONS

3.6 CONSTRUCTION ALLOWANCE

An allowance of 20% has been made to cover construction (post contract) unknowns. This allowance, also known as the Post Contract Contingency (PCC), is intended to cover costs for change orders during construction that are not foreseeable. It is not intended to cover scope changes to the contract. The amount carried in a budget for this allowance is typically set at the initial planning stage and should be based on the complexity of the project and the probability of unknowns and retained risks.

3.7 CASH ALLOWANCE

Cash allowances are intended to allow the contractor to include in the bid price the cost for work that is difficult to fully scope at the time of tendering based on factors that are beyond the Owner and Prime Consultant's control. Cash allowances attempt to reduce the risks by dedicating a set amount for use against a certain cost that cannot yet be detailed. The Contractor is obligated to work as best as possible within the limitations of the Cash Allowance.

Examples of Cash Allowances include hardware, inspection and testing, site conditions, replacement of existing elements during demolition for renovation, hazardous materials abatement, signage, etc.

Any Cash Allowances if applicable are included either in the details of this estimate under the appropriate discipline or at the summary level.

3.8 TAXES

No provision has been made for the Goods and Services Tax. It is recommended that the owner make separate provision for GST in the project budget.

3.9 SCHEDULE

Pricing assumes a standard schedule of work appropriate to the size and scope of this project. Premiums for off-hour work, working in an operational facility, accelerated schedule, etc., if applicable, are identified separately in the body of the estimate.

3.10 STATEMENT OF PROBABLE COSTS

Hanscomb has no control over the cost of labour and materials, the contractor's method of determining prices, or competitive bidding and market conditions. This opinion of probable cost of construction is made on the basis of experience, qualifications and best judgment of the professional consultant familiar with the construction industry. Hanscomb cannot and does not guarantee that proposals, bids or actual construction costs will not vary from this or subsequent cost estimates.

3. COST CONSIDERATIONS

3.11 ONGOING COST CONTROL

Hanscomb recommends that the Owner and design team carefully review this document, including line item description, unit prices, clarifications, exclusions, inclusions and assumptions, contingencies, escalation, and mark-ups. If the project is over budget, or if there are unresolved budgeting issues, alternative systems/schemes should be evaluated before proceeding into the next design phase.

It is recommended that a final updated estimate at the end of the design stage be produced by Hanscomb using Bid Documents to determine overall cost changes which may have occurred since the preparation of this estimate. The final updated estimate will address changes and additions to the documents, as well as addenda issued during the bidding process. Hanscomb cannot reconcile bid results to any estimate not produced from bid documents including all addenda.

This estimate does not constitute an offer to undertake the work, nor is any guarantee given that an offer, to undertake the work at the estimate(s) price, will subsequently be submitted by a construction contractor. Unless explicitly stated otherwise, it is assumed that competitive bids will be sought when tender documents have been completed. Any significant deviation between bids received and a pre-tender estimate prepared by Hanscomb from the same tender documents, should be evaluated to establish the possible cause(s).

4. GROSS FLOOR AREAS

Gross Floor Area

Description	m2
Main Floor - Hanger	2,947
Main Floor West Support	802
Main Floor East Support	845
Second Floor	1,188
Third Floor	1,157
Roof Access Room	24
Total Gross Floor Area	6,963

The above areas have been measured in accordance with the Canadian Institute of Quantity Surveyors' Method of Buildings by Area and Volume.

4. PROJECT COST ESTIMATE SUMMARY

	Hazardous Material Abatement	Stabilization Arch / Mech / Elect	Stabilization Structural	Conservation Arch / Mech / Elect	Conservation Structural	TOTALS
- Direct Construction	525,300	4,550,000	3,753,300	16,527,100	1,628,800	26,984,500
Sub-Totals	525,300	4,550,000	3,753,300	16,527,100	1,628,800	26,984,500
- General Site Requirements	44,600	386,700	319,000	1,404,800	138,500	2,293,600
- Contractors Fee	28,500	246,800	203,600	896,600	88,400	1,463,900
Sub-Total- Excl. Contingencies	598,400	5,183,500	4,275,900	18,828,500	1,855,700	30,742,000
- Design and Pricing Allowance	119,700	1,036,700	855,200	3,765,700	371,100	6,148,400
- Escalation Allowance	21,600	186,700	153,900	677,800	66,800	1,106,800
- Construction Allowance	147,900	1,281,400	1,057,100	4,654,400	458,600	7,599,400
Sub-Total- Incl. Contingencies	887,600	7,688,300	6,342,100	27,926,400	2,752,200	45,596,600
- Goods & Services Tax	Excluded	Excluded	Excluded	Excluded	Excluded	Excluded
Total Construction Estimate	887,600	7,688,300	6,342,100	27,926,400	2,752,200	45,596,600
Project Related Costs (Soft Costs)	320,700	2,709,600	2,236,700	8,268,000	821,800	14,356,800
Total Project Estimate (exc GST)	1,208,300	10,397,900	8,578,800	36,194,400	3,574,000	59,953,400

**Appendix
A - Detailed Elemental Estimate- Stabilization**

Project Name: Hanger 11 - Blatchford

Project Description: City of Edmonton - Hanger 11 Rehabilitation

STABILIZATION PLAN NOTES

		Qty	Unit	Rate	Total
SP-01	Partially abate designated substances in the building as needed to arrest mould growth and complete stabilization work below (see 2015 Hazmat Summary Report by Golder Associates)	Refer Project Cost Summary	m2	\$0.00	
SP-02	Provide temporary shoring to stabilize compromised floor structure on the west ancillary wing (third floor to foundation, engineer to confirm final locations)	649	m2	\$480.00	\$311,520
SP-03	Fully replace flat roof membrane system down to bare deck, including air/vapour barrier, underlayment, insulation, BUR membrane, related flashings and tie-ins (see roof type R1)	1678	m2	\$704.00	\$1,181,312
SP-04	Fully replace hangar roof membrane system down to bare deck, including air/vapour barrier, underlayment, insulation, SBS membrane, and related flashings and tie-ins (see roof type R2)	2916	m2	\$364.00	\$1,061,424
SP-05	Remove water saturated batt insulation, vapour barrier and ceiling finishes at u/s of flat roofs	225	m2	\$110.00	\$24,750
SP-06	Remove water saturated batt insulation, vapour barrier and drywall finishes from exterior walls	463	m2	\$150.00	\$69,450
SP-07	Remove water saturated ceiling and floor finishes from west wing, down to bare floor deck	260	m2	\$170.00	\$44,200
SP-08	Re-connect temporary power and run multiple floor dryers, industrial portable blower fans and dehumidifier units at each floor and several within the main hangar space	6963	m2	\$100.00	\$696,300
SP-09	Provide minimum temporary heat within the building (5C) during winter and shoulder seasons using flameless construction heaters	1	Allow	\$80,000.00	\$80,000
SP-10	Install digital hygrothermographic sensors at multiple points in the building to measure temperature and humidity levels for full cycle of seasons (1 year)	1	Allow	\$16,000.00	\$16,000
SP-11	Install temporary plywood sheathing at interior side of all ground floor windows	45	No.	\$660.00	\$29,700
SP-12	Install fire and security surveillance/warning system, possibly monitored as part of site management	6963	m2	\$80.00	\$557,040
SP-13	Install exterior wall-mounted commercial flood lights around building for security	6964	m2	\$16.10	\$112,120
SP-14	Provide temporary string work lights in all interior corridors and main hangar space	1	Sum	\$18,000.00	\$18,000
SP-15	Fully replace caulking joints at windows, flashings and roof penetrations	6963	m2	\$50.00	\$348,150
Total Section 1.0 - NET Construction Cost					\$4,550,000
General Site Requirements & Contingencies					
2.10	Contractor's Site Requirements	\$4,550,000		8.5%	\$386,750
2.20	Contractor's Fee	\$4,936,750		5.0%	\$246,838
2.30	Design & Pricing Allowance	\$5,183,588		20.0%	\$1,036,718
2.40	Escalation (allow 2 years)	\$6,220,305		3.0%	\$186,609
2.50	Construction Allowance	\$6,406,914		20.0%	\$1,281,383
Total Section 2.0 - General Site Requirements / Contingencies					\$3,138,300
TOTAL ESTIMATED CONSTRUCTION COST					\$7,688,300

Project Name: Hanger 11 - Blatchford

Project Description: City of Edmonton - Hanger 11 Rehabilitation

STABILIZATION PLAN NOTES

		Qty	Unit	Rate	Total
	Project Related Costs				
3.10	Project Management- Construction/Administration			7.00%	\$538,181
3.20	Design, Engineering, Environmental Permitting, etc. (Consultants)			11.00%	\$845,713
3.30	Construction Manager Design Assist		Allow		\$7,500
3.40	Allowance for Environmental/Geotechnical reports/surveys and the like			4.00%	\$307,532
3.50	Material Testing / Inspections			1.50%	\$115,325
3.60	Heritage Status			2.0%	\$153,766
3.70	City of Edmonton Overhead Fee			3.25%	\$313,830
3.80	City of Edmonton PM Fee			1.10%	\$109,672
3.90	Escalation Allowance- Soft Costs (allow 2 years)			3.00%	\$71,746
4.00	Soft Cost Contingency			10.00%	\$246,326
	Total Section 3.0 - Project Related Costs				\$2,709,600

TOTAL ESTIMATED PROJECT COST				\$10,397,900
-------------------------------------	--	--	--	---------------------

STABILIZATION PLAN NOTES

		Qty	Unit	Rate	Total
SSP-01	• Hanger: expect to complete isolated repairs on approximately 10-20% of the roof deck and joists. Temporary repairs to 5-15% of the ceiling framing, the glulam trusses. Temporary repairs to 25% of the truss columns and braces				
a	Structural Repair to roof deck- allow 20% of total roof area	583.2	m2	\$575.00	\$335,340
b	Structural Repair to roof joists- allow 20% of total roof area	583.2	m2	\$625.00	\$364,500
c	Structural Repair to roof trusses	11	No.	\$15,000.00	\$165,000
d	Structural Repair to truss columns	22	No.	\$7,500.00	\$165,000
e	Structural Repair to truss column braces	22	No.	\$3,500.00	\$77,000
SSP-02	• Western ancillary building: replacement or repair of approximately 50-70% of the floor and roof joists. Upgrading or repair to approximately 15-30% of the post and beams.				
a	replacement or repair of approximately 70% of the roof joists.	561.4	m2	\$525.00	\$294,735
b	replacement or repair of approximately 70% of the floor joists.	820.4	m2	\$575.00	\$471,730
c	Upgrading or repair to approximately 30% of the post and beams.	592.2	m2	\$550.00	\$325,710
SSP-03	• Eastern ancillary building: Replacement or repair of approximately 30-40% of the floor and roof joists. Upgrading or repair to approximately 5-15% of the post and beams.				
a	replacement or repair of approximately 40% of the roof joists.	338	m2	\$525.00	\$177,450
b	replacement or repair of approximately 40% of the floor joists.	468.8	m2	\$575.00	\$269,560
c	Upgrading or repair to approximately 30% of the post and beams.	605.1	m2	\$550.00	\$332,805
SSP-04	• Repair or reconstruct approximately 60-75% of the walls on the east/west sides of hanger	1675.5	m2	\$275.00	\$460,763
SSP-05	• In-depth lateral analysis based on expected remaining walls. Anticipate construction of 5-10% of the existing walls with standard sheathed shear walls as a temporary measure.	558.5	m2	\$250.00	\$139,625
SSP-06	• Removal and/or reinforcing of exterior framing that has deteriorated (due to being exposed), to approximately 5-10% of exterior of the building.	Carried in Architectural Estimate			
SSP-07	• Shoring of certain areas to complete either structural or non-structural repairs.	6963	m2	\$25.00	\$174,075
Total Section 1.0 - NET Construction Cost					\$3,753,300
General Site Requirements & Contingencies					
2.10	Contractor's Site Requirements	\$3,753,300		8.5%	\$319,031
2.20	Contractor's Fee	\$4,072,331		5.0%	\$203,617
2.30	Design & Pricing Allowance	\$4,275,947		20.0%	\$855,189
2.40	Escalation (allow 2 years)	\$5,131,136		3.0%	\$153,934
2.50	Construction Allowance	\$5,285,071		20.0%	\$1,057,014
Total Section 2.0 - General Site Requirements / Contingencies					\$2,588,800
TOTAL ESTIMATED CONSTRUCTION COST					\$6,342,100
Project Related Costs					
3.10	Project Management- Construction/Administration	\$6,342,100		7.00%	\$443,947
3.20	Design, Engineering, Environmental Permitting, etc. (Consultants)	\$6,342,100		11.00%	\$697,631
3.30	Construction Manager Design Assist	Allow			\$7,500
3.40	Allowance for Environmental/Geotechnical reports/surveys and the like	\$6,342,100		4.00%	\$253,684
3.50	Material Testing / Inspections	\$6,342,100		1.50%	\$95,132
3.60	Heritage Status	\$6,342,100		2.0%	\$126,842
3.70	City of Edmonton Overhead Fee	\$7,966,836		3.25%	\$258,922
3.80	City of Edmonton PM Fee	\$8,225,758		1.10%	\$90,483
3.90	Escalation Allowance- Soft Costs (allow 2 years)	\$1,974,141		3.00%	\$59,224
4.00	Soft Cost Contingency	\$2,033,365		10.00%	\$203,337
Total Section 3.0 - Project Related Costs					\$2,236,700
TOTAL ESTIMATED PROJECT COST					\$8,578,800

**Appendix
B - Detailed Elemental Estimate- Conservation**

Project Name: Hanger 11 - Blatchford

Project Description: City of Edmonton - Hanger 11 Rehabilitation

CONSERVATION PLAN NOTES

		Qty	Unit	Rate	Total
CP-01	Strip existing painted timber post and beam structure down to bare wood substrate, consolidate decayed areas as needed	6963	m2	\$125.00	\$870,375
CP-02	Strip paint from existing chimney and fully repoint masonry joints, replace up to 15 damaged bricks; fabricate new precast concrete capstone to match existing	124	m2	\$235.00	\$29,140
CP-03	Provide all new base flashings for chimney stack	124	m2	\$250.00	\$31,000
CP-04	Refurbish freight elevator in west ancillary wing (keep non-operational)	1	Sum	\$20,000.00	\$20,000
	Option 1 Replace existing freight elevator with functioning elevator system			See separate price for CP-04 Option 1	
CP-05	Clean existing hanger floor slab, lightly polish and seal with clear penetrant	2808	m2	\$75.00	\$210,600
CP-06	Fully abate designated substances inside building (see 2015 Hazmat Summary Report by Golder Associates)	Refer Project Cost Summary			
CP-07	Demolish all remaining non-structural interior partitions, drop ceilings, floor and wall finishes in ancillary wings, remove all redundant building services	4941	m2	\$150.00	\$741,150
CP-08	Remove existing deteriorated sections of floor on the west ancillary wing and infill with new wood floor structure	1197	m2	\$225.00	\$269,325
CP-09	Apply 2 coats of intumescent paint to expose timber post and beam structure and bowstring trusses	2754	m2	\$165.00	\$454,410
CP-10	Strip existing paint from interior hangar walls, replace deteriorated wall panels with matching plywood panels, paint 1 coat primer, 2 coats acrylic latex enamel	988	m2	\$130.00	\$128,440
CP-11	Clean, repair and restore (17) interior hangar-facing wood windows by repairing wood decay, re-painting exterior and interior surfaces and replacing putty and sealant around window frames	17	No.	\$1,000.00	\$17,000
CP-12	Install wood storm on interior side of (17) original wood windows to improve thermal efficiency and reduce condensation	17	No.	\$800.00	\$13,600
CP-13	Replace contemporary aluminum windows and provide (276) new metal-clad wood double hung windows to match original one-over-one sash frames	276	No.	\$2,000.00	\$552,000
CP-14	Replace (24) exterior man doors with new insulated metal doors w/ hardware, locksets	24	No.	\$2,400.00	\$57,600
CP-15	Remove ceiling panels in hangar	2754	m2	\$60.00	\$165,240
CP-16	Provide new wall, floor and ceiling finishes throughout ancillary wings where floors are not being refurbished	4941	m2	\$195.00	\$963,495
CP-17	Remove existing cladding system down to sheathing and provide new rainscreen assembly (see wall type W1), including new insulation and flashings; provide local replacement/repairs to underlying diagonal wood board sheathing as needed	2234	m2	\$750.00	\$1,675,500
CP-18	Remove existing exterior wood fire escapes, close in wall openings with new framed assembly			Refer CP 028	
CP-19	Hangar Doors:				
	Option 1 (rebuild): Rebuild hangar doors w/ new steel frame, insulate w/ spray foam, new sheet metal cladding over pressure-treated plywood substrate to match original appearance, provide new automated track system and rollers;	24	No.	\$49,400.00	\$1,185,600
	Option 2 (refurbish): Strip down existing hangar doors to timber frame, re-insulate with spray foam, provide new sheet metal cladding over pressure-treated plywood substrate to match original appearance, provide new automated track system and rollers;	24	No.	See separate price for CP-19 Option 2	
	Option 3 (fix in place): Partially refurbish existing hangar doors to prevent further deterioration. Reinststate and fix in place as a non-functional historic artefact. Enclose hangar door openings with new contemporary glazing system	24	No.	See separate price for CP-19 Option 3	

Project Name: Hanger 11 - Blatchford

Project Description: City of Edmonton - Hanger 11 Rehabilitation

CONSERVATION PLAN NOTES

		Qty	Unit	Rate	Total
CP-20	Remove laminated wood embeds from hanger ground floor concrete slab, patch with new poured concrete and make good surfaces	2808	m2	\$100.00	\$280,800
	Option 1 Remove and Replace in-kind with pressure treated wood, make good surfaces			See separate price for CP-20 Option 1	
CP-21	Patch saturated areas of plywood subfloor with new pressure-treated plywood	113	m2	\$350.00	\$39,550
CP-22	Remove embedded wood trench drain and replace with new industrial steel trench drain cover plate to match	90	LM	\$1,500.00	\$135,000
CP-23	Refurbish wood flooring in east ancillary wing, as well as south half of second floor in west wing; locally replace missing floor boards as needed	2936	m2	\$160.00	\$469,760
CP-24	Provide local patch repairs to concrete floor slab where cracking or superficial damage has occurred	2808	m2	\$50.00	\$140,400
CP-25	Install new fire protection and life safety systems, system controls, HVAC, electrical, lighting, plumbing, stormwater management and sprinkler systems	1	Sum	\$6,021,530.00	\$6,021,530
CP-26	Provide new exterior lighting (exclude as site work?)	1	Sum	\$50,000.00	\$50,000
CP-27	Provide washrooms and accessibility upgrades	129	m2	\$3,150.00	\$406,350
CP-28	Provide other code upgrades	1	Allow	\$1,594,150.00	\$1,594,150
CP-29	Retain, or salvage and reuse, interior wood panel doors	33	No.	\$155.00	\$5,115
Total Section 1.0 - NET Construction Cost					\$16,527,100

General Site Requirements & Contingencies				
2.10	Contractor's Site Requirements	\$16,527,100	8.5%	\$1,404,804
2.20	Contractor's Fee	\$17,931,904	5.0%	\$896,595
2.30	Design & Pricing Allowance	\$18,828,499	20.0%	\$3,765,700
2.40	Escalation (allow 2 years)	\$22,594,198	3.0%	\$677,826
2.50	Construction Allowance	\$23,272,024	20.0%	\$4,654,405
Total Section 2.0 - General Site Requirements / Contingencies				\$11,399,300

TOTAL ESTIMATED CONSTRUCTION COST				\$27,926,400
------------------------------------------	--	--	--	---------------------

Project Related Costs				
3.10	Project Management- Construction/Administration	\$27,926,400	7.00%	\$1,954,848
3.20	Design, Engineering, Environmental Permitting, etc. (Consultants)	\$27,926,400	11.00%	\$3,071,904
3.30	Construction Manager Design Assist	Allow		\$7,500
3.40	Allowance for Environmental/Geotechnical reports/surveys and the like	\$27,926,400	4.00%	\$1,117,056
3.50	Material Testing / Inspections	\$27,926,400	1.50%	\$418,896
3.60	Heritage Status	\$27,926,400	2.0%	\$558,528
3.70	City of Edmonton Overhead Fee	\$35,055,132	3.25%	\$1,139,292
3.80	City of Edmonton PM Fee	\$36,194,424	1.10%	\$398,139
3.90	Escalation Allowance- Soft Costs (allow 2 years)	\$8,666,162	3.00%	\$259,985
4.00	Soft Cost Contingency	\$8,926,147	10.00%	\$892,615
Total Section 3.0 - Project Related Costs				\$8,268,000

TOTAL ESTIMATED PROJECT COST				\$36,194,400
-------------------------------------	--	--	--	---------------------

Project Name: Hanger 11 - Blatchford

Project Description: City of Edmonton - Hanger 11 Rehabilitation - **STRUCTURAL UPGRADES**

CONSERVATION PLAN NOTES

		Qty	Unit	Rate	Total
SCP-01	• Based on preliminary use plans, the buildings would need to be split into three buildings, requiring firewalls on east/west walls of the hanger				
a	Providing new foundation for firewalls	122	m	\$1,250.00	\$152,500
b	Double wall be built including modification of existing framing in ancillary areas to bear on new wall and new foundations.	Carried in Architectural Estimate			
c	Modification of existing framing in ancillary areas to bear on new wall and new foundations	366	m	\$650.00	\$237,900
d	Assume 2 steel cross brace (or wood shear walls) being added on all four sides.	8	No.	\$7,500.00	\$60,000
SCP-02	• Repairs to the existing walls in the ancillary buildings will be required to upgrade or restore the lateral system for these buildings.				
a	Assume 20% of the interior walls being re-built.	988	m2	\$275.00	\$271,700
SCP-03	• Repairs to existing structure that has been modified during building use. There are several locations where members have been cut or modified, so repairs would be required to restore these areas.				
a	Assume 1 to 3% of the entire structure would require these type of repairs for costing purposes.	208.89	m2	\$490.00	\$102,356
SCP-04	• Foundation upgrades to the building to support new loads. This is significant undertaking as generally there is no information available for these structures, which will likely lead to upgrading required.				
a	Assume 25 to 40% of the structure will require foundation modifications.	2785.2	m2	\$115.00	\$320,298
SCP-05	• Restoration of north and south walls likely would be required including removal of finishes and replacement of framing of small roofs. This is especially true if repairing/restoring overhead doors.	968	m2	\$500.00	\$484,000
Total Section 1.0 - NET Construction Cost					\$1,628,800
General Site Requirements & Contingencies					
2.10	Contractor's Site Requirements	\$1,628,800		8.5%	\$138,448
2.20	Contractor's Fee	\$1,767,248		5.0%	\$88,362
2.30	Design & Pricing Allowance	\$1,855,610		20.0%	\$371,122
2.40	Escalation (allow 2 years)	\$2,226,732		3.0%	\$66,802
2.50	Construction Allowance	\$2,293,534		20.0%	\$458,707
Total Section 2.0 - General Site Requirements / Contingencies					\$1,123,400
TOTAL ESTIMATED CONSTRUCTION COST					\$2,752,200
Project Related Costs					
3.10	Project Management- Construction/Administration	\$2,752,200		7.00%	\$192,654
3.20	Design, Engineering, Environmental Permitting, etc. (Consultants)	\$2,752,200		11.00%	\$302,742
3.30	Construction Manager Design Assist	Allow			\$7,500
3.40	Allowance for Environmental/Geotechnical reports/surveys and the like	\$2,752,200		4.00%	\$110,088
3.50	Material Testing / Inspections	\$2,752,200		1.50%	\$41,283
3.60	Heritage Status	\$2,752,200		2.0%	\$55,044
3.70	City of Edmonton Overhead Fee	\$3,461,511		3.25%	\$112,499
3.80	City of Edmonton PM Fee	\$3,574,010		1.10%	\$39,314
3.90	Escalation Allowance- Soft Costs (allow 2 years)	\$861,124		3.00%	\$25,834
4.00	Soft Cost Contingency	\$886,958		10.00%	\$88,696
Total Section 3.0 - Project Related Costs					\$821,800
TOTAL ESTIMATED PROJECT COST					\$3,574,000

Hanscomb: Celebrating More than 60 Years of Excellence in the Construction Industry

Hanscomb Limited, a leading independent organization of project control specialists, has been privileged to serve both Canadian and international clients on a wide variety of construction projects for over 60 years. By planning, monitoring and controlling cost in an unbiased independent professional manner, Hanscomb has become an internationally recognized leader in the coordinated management of capital projects.

Our growing team of trusted professionals and experts consists of quantity surveyors, cost consultants, project monitors, schedulers and value specialists, skilled in a remarkable variety of project sectors including but not limited to transportation, civil infrastructure, education, healthcare, residential, and commercial. Hanscomb takes pride in the multi-disciplinary character of the company and the ability of its people to bring together, in a team, the professional and practical skills of the very diverse field of quantity surveying.

Our nationwide network of offices and worldwide associates allows for the easy exchange of information, skills and resources ensuring we stay abreast of the latest in design, construction practices and trends. With offices located coast to coast, Hanscomb has the local experience and worldwide presence to keep your projects on track.

Cost Planning & Control

- Master plan costing
- Construction cost estimates
- Replacement cost estimates

Scheduling

Value Management

Financial Analysis

- Life cycle costing
- Operations and maintenance
- Cost / benefit analysis
- Feasibility studies

Applied Research

- Construction price indexing
- Risk and gap analysis
- Cost publications

Project Loan Monitoring

Project Management

Litigation Support

From east to west, our leadership team is here to serve you. We collaborate on many projects nationally and internationally and are available to assist you. For information please contact us:

Raymond Murray, Vice President	halifax@hanscomb.com	(902) 422-3620
Art Maw, President	ottawa@hanscomb.com	(613) 234-8089
Brian McBurney, Director	ottawa@hanscomb.com	(613) 234-8089
Susan Neil, Executive Vice President	toronto@hanscomb.com	(416) 487-3811
Dale Panday, Director	toronto@hanscomb.com	(416) 487-3811
Nathan Thinagarippillai, Manager	toronto@hanscomb.com	(416) 487-3811
Murugan Thambiayah, Manager M&E Toronto	toronto@hanscomb.com	(416) 487-3811
Craig Bye, Director	hamilton@hanscomb.com	(905) 525-5777
Isaac Gwendo, Director	winnipeg@hanscomb.com	(204) 775-3389
Mike Swick, Director	edmonton@hanscomb.com	(780) 426-7980
Ken King, Manager	vancouver@hanscomb.com	(604) 685-1241





NOT FOR CONSTRUCTION

HANGAR 11

Project Address: Edmonton, Alberta

Project No. 19-021

Issued for

CONSERVATION PLAN

October 29, 2019

ERA

HERITAGE ARCHITECT

ERA Architects
625 Church St, Suite 600, Toronto, ON M4Y 2G1

HERITAGE DRAWING LIST

C0.1	Notes & Assemblies
C1.1	Plans
C1.2	Plans
C3.1	Elevations
C3.2	Elevations
C4.1	Sections
C4.2	Sections

WALL & ROOF ASSEMBLIES

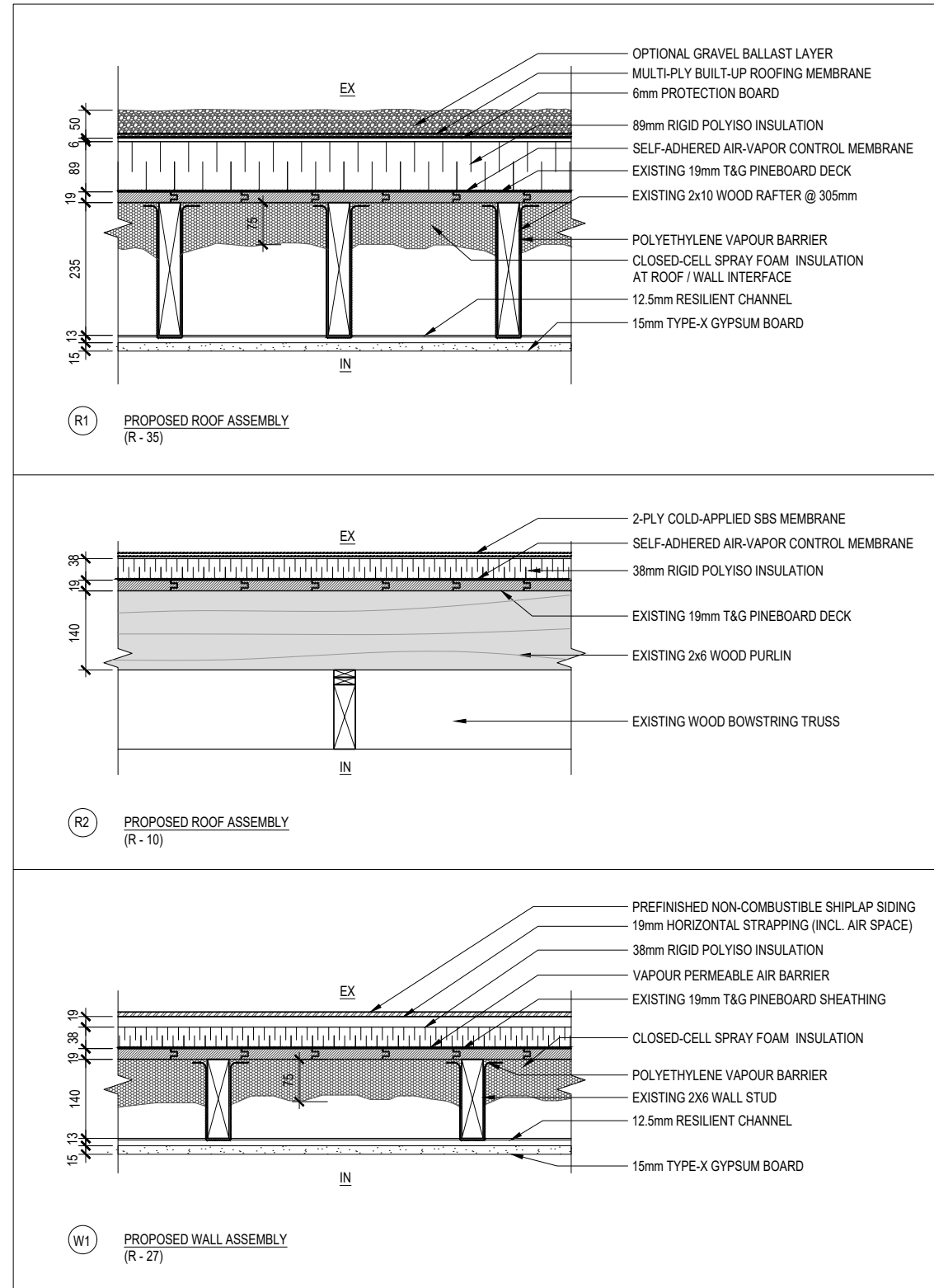

CONSERVATION PLAN NOTES

- CP-01 Strip existing painted timber post and beam structure down to bare wood substrate, consolidate decayed areas as needed;
- CP-02 Strip paint from existing chimney and fully repoint masonry joints, replace up to 15 damaged bricks; fabricate new precast concrete capstone to match existing;
- CP-03 Provide all new base flashings for chimney stack;
- CP-04 Freight elevator:
 - Option 1 (refurbish): Refurbish freight elevator in west ancillary wing (keep non-operational);
 - Option 2 (replace): Replace existing freight elevator with functioning elevator system;
- CP-05 Clean existing floor slab, lightly polish and seal with clear penetrant;
- CP-06 Fully abate designated substances inside building (see 2015 Hazmat Summary Report by Golder Associates);
- CP-07 Abate and dispose of all remaining non-structural interior partitions, drop ceilings, floor and wall finishes in ancillary remove all redundant building services;
- CP-08 Remove existing deteriorated sections of floor on the west ancillary wing and infill with new wood floor structure;
- CP-09 Apply 2 coats of intumescent paint to expose timber post and beam structure and bowstring trusses for fire protection;
- CP-10 Strip existing paint from interior hangar walls, replace deteriorated wall panels with matching plywood panels, paint 1 coat primer, 2 coats acrylic latex enamel;
- CP-11 Clean, repair and restore (17) interior hangar-facing wood windows by repairing wood decay, re-painting exterior and interior surfaces and replacing putty and sealant around window frames. Replace windows to match where required;
- CP-12 Install wood storm windows on office-facing side of (17) original wood windows to improve thermal efficiency and reduce condensation;
- CP-13 Replace contemporary aluminum windows and provide (276) new metal-clad wood double hung windows to match original one-over-one sash frames;
- CP-14 Replace (24) exterior doors with new insulated metal doors w/ hardware, locksets;
- CP-15 Abate and dispose of ceiling panels in hangar;
- CP-16 Provide new wall, floor and ceiling finishes throughout ancillary wings where floors are not being refurbished;
- CP-17 Remove existing cladding system down to sheathing and provide new rainscreen assembly (see wall type W1), including new insulation and flashings; provide local replacement/repairs to underlying diagonal wood board sheathing as needed;
- CP-18 Exterior wooden staircases and wooden ladders:
 - Option 1 (rebuild): Abate and dispose of existing exterior wooden staircases and ladders and rebuild (4) existing exterior wooden staircases and (3) existing exterior wooden ladders to match;
 - Option 2 (remove): Abate and dispose of existing exterior wooden staircases and ladders, and close in wall openings with new framed assembly;
- CP-19 Hangar doors:
 - Option 1 (rebuild): Rebuild hangar doors w/ new steel frame, insulate w/ spray foam, new sheet metal cladding over pressure-treated plywood substrate to match original appearance, provide new automated track system and rollers;
 - Option 2 (refurbish): Strip down existing hangar doors to bare timber frame, re-insulate with spray foam, provide new sheet metal cladding over pressure-treated plywood substrate to match original appearance, provide new automated track system and rollers;
 - Option 3 (fix in place): Partially refurbish existing hangar doors to prevent further deterioration. Reinstate and fix in place as a non-functional historic artefact. Enclose hangar door openings with new contemporary glazing system;
- CP-20 Laminated wood embeds at ground floor concrete slab:
 - Option 1 (patch): Remove and patch with new poured concrete, and make good all surfaces;
 - Option 2 (replace): Remove and replace in-kind w/ pressure treated wood, and make good all surfaces;
- CP-21 Patch saturated areas of plywood subfloor with new pressure-treated plywood;
- CP-22 Remove embedded wood trench drain and replace with new industrial steel trench drain cover plate to match;
- CP-23 Refurbish wood flooring in east ancillary wing, as well as south half of second floor in west wing; locally replace missing floor boards as needed;
- CP-24 Provide local patch repairs to concrete floor slab where cracking or superficial damage has occurred;

CONSERVATION PLAN NOTES (CONTINUED)

- CP-25 Install 2-stage fire alarm and life safety systems, system controls, new power and telecommunications services, lighting, HVAC, plumbing, sanitary services, stormwater management and automatic sprinkler system throughout;
- CP-26 Provide new exterior lighting;
- CP-27 Provide new washrooms and accessibility upgrades;
- CP-28 Provide other code updates, including, but not limited to:
 - Provision of 2 new passenger elevators (one for each ancillary wing), providing a barrier free path of travel;
 - Reconstruction of each of the existing four (4) interior stair cores, with fire separations having a resistance rating of 1-hour;
- CP-29 Retain, or salvage and reuse, interior wood panel doors. Strip doors to bare wood surface and repaint.

STABILIZATION PLAN NOTES

- SP-01 Partially abate designated substances in the building as needed to arrest mould growth and complete stabilization work below (see 2015 Hazmat Summary Report by Golder Associates);
- SP-02 Provide temporary shoring to stabilize compromised floor structure on the west ancillary wing (third floor to foundation, engineer to confirm final locations);
- SP-03 Fully replace flat roof membrane system down to bare deck, including air/vapour barrier, underlayment, insulation, BUR membrane, related flashings and tie-ins (see roof type R1);
- SP-04 Fully replace hangar roof membrane system down to bare deck, including air/vapour barrier, underlayment, insulation, SBS membrane, and related flashings and tie-ins (see roof type R2);
- SP-05 Remove water saturated batt insulation, vapour barrier and ceiling finishes at u/s of flat roofs;
- SP-06 Remove water saturated batt insulation, vapour barrier and drywall finishes from exterior walls;
- SP-07 Remove water saturated ceiling and floor finishes from west wing, down to bare floor deck;
- SP-08 Re-connect temporary power and run multiple floor dryers, industrial portable blower fans and dehumidifier units at each floor and several within the main hangar space;
- SP-09 Provide minimum temporary heat within the building (5°C) during winter and shoulder seasons using flameless construction heaters;
- SP-10 Install digital hygrothermographic sensors at multiple points in the building to measure temperature and humidity levels for full cycle of seasons (1 year);
- SP-11 Install temporary plywood sheathing at interior side of all ground floor windows;
- SP-12 Install fire and security surveillance/warning system, monitored as part of site management;
- SP-13 Install exterior wall-mounted commercial flood lights around building for security;
- SP-14 Provide temporary string work lights in all interior corridors and main hanger space;
- SP-15 Fully replace caulking joints at windows, flashings and roof penetrations.

GENERAL NOTES

1. The abatement of hazardous materials is costed as a separate scope of work as it is currently unclear if existing building conditions will allow for a two-phase abatement. The abatement scope of work, and costs associated, may change during the course of work to be undertaken.

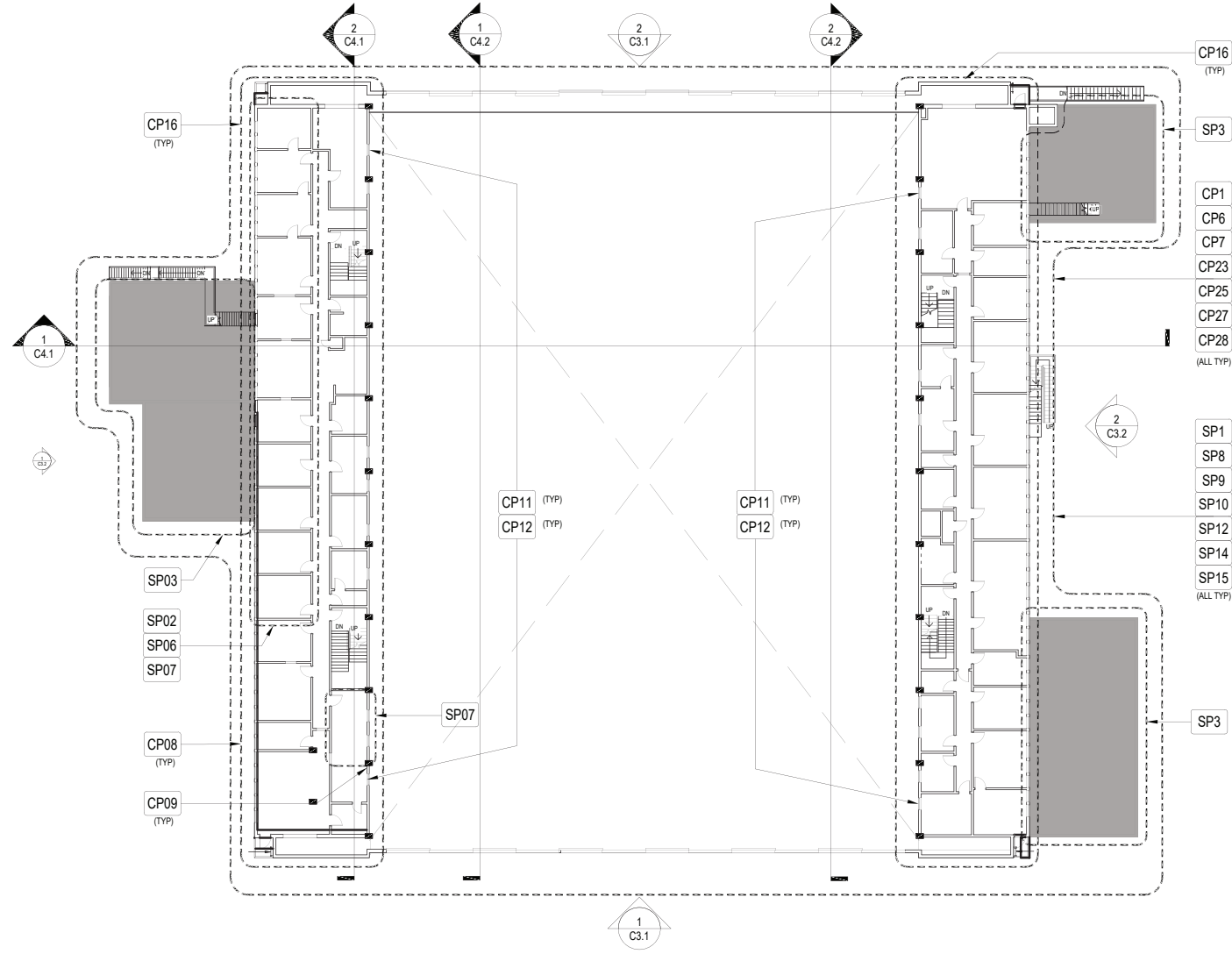

SECOND FLOOR PLAN 2
SCALE 1 : 500 C1.1

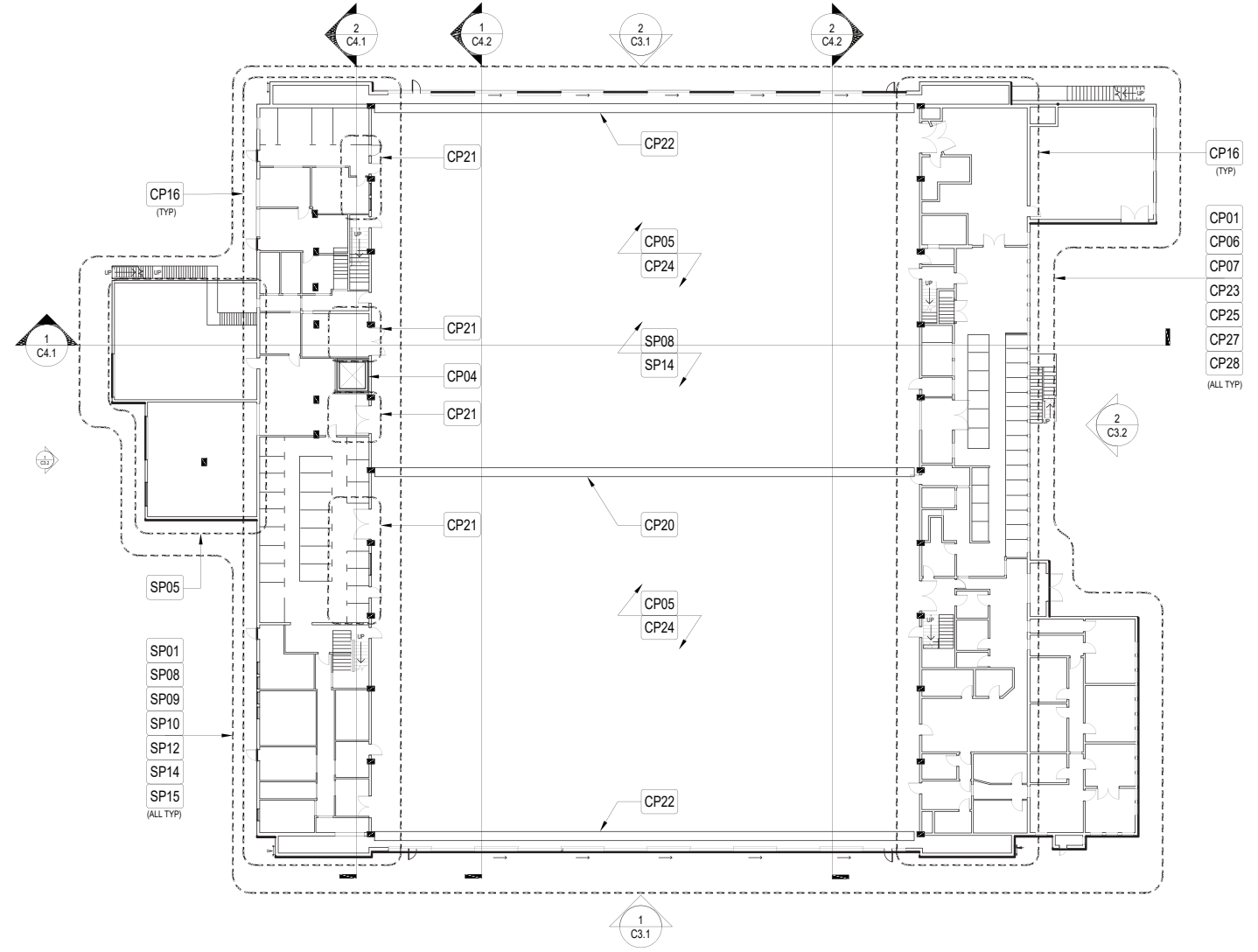

GROUND FLOOR PLAN 1
SCALE 1 : 500 C1.1

C1.1

NOT FOR CONSTRUCTION

CONSERVATION PLANS
Hangar 11 | Scale - AS NOTED | Drawing No. C1.1

www.eraarch.ca
1.416.963.4497
E.R.A.Architects Inc.



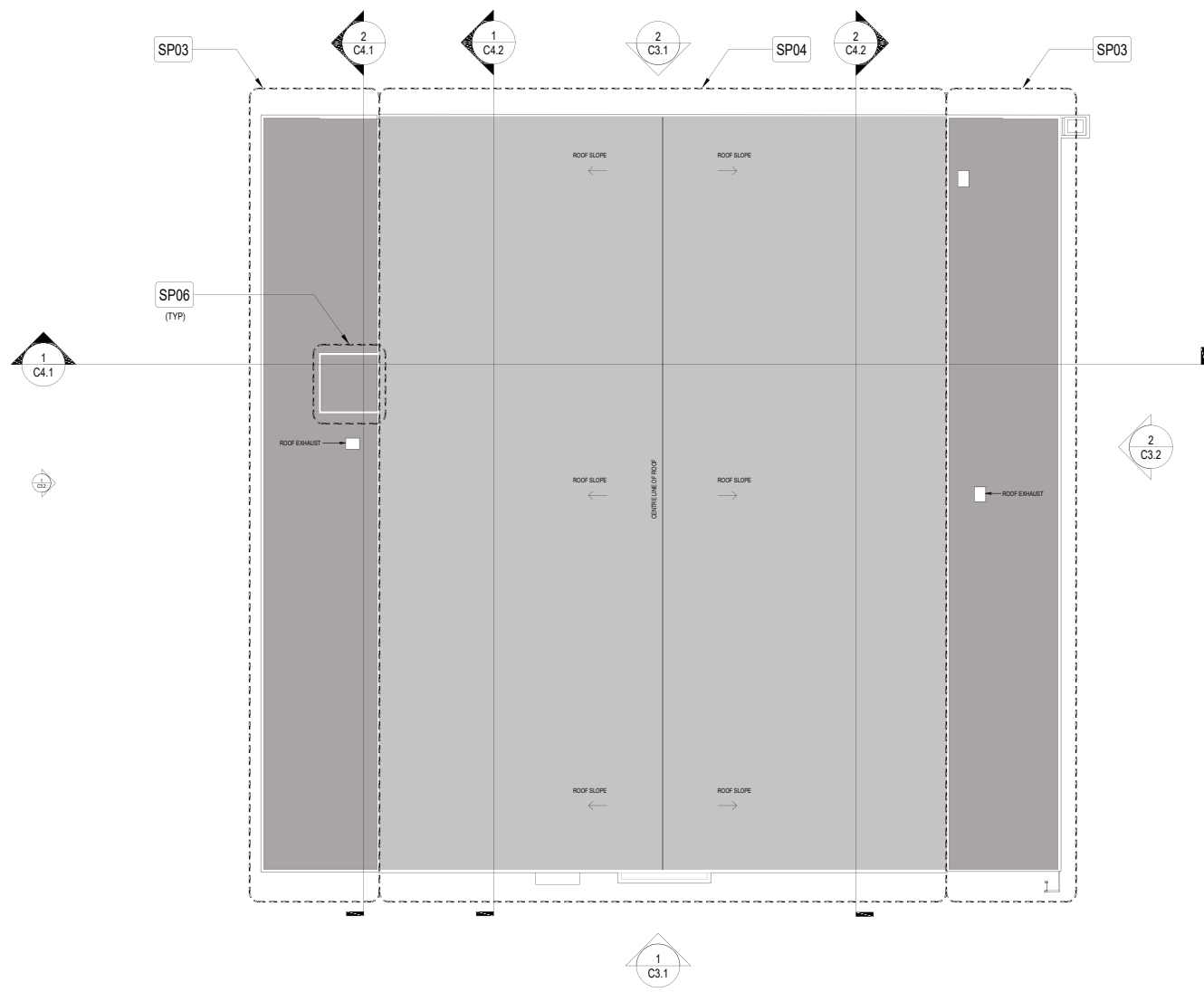

ROOF PLAN
SCALE 1 : 500

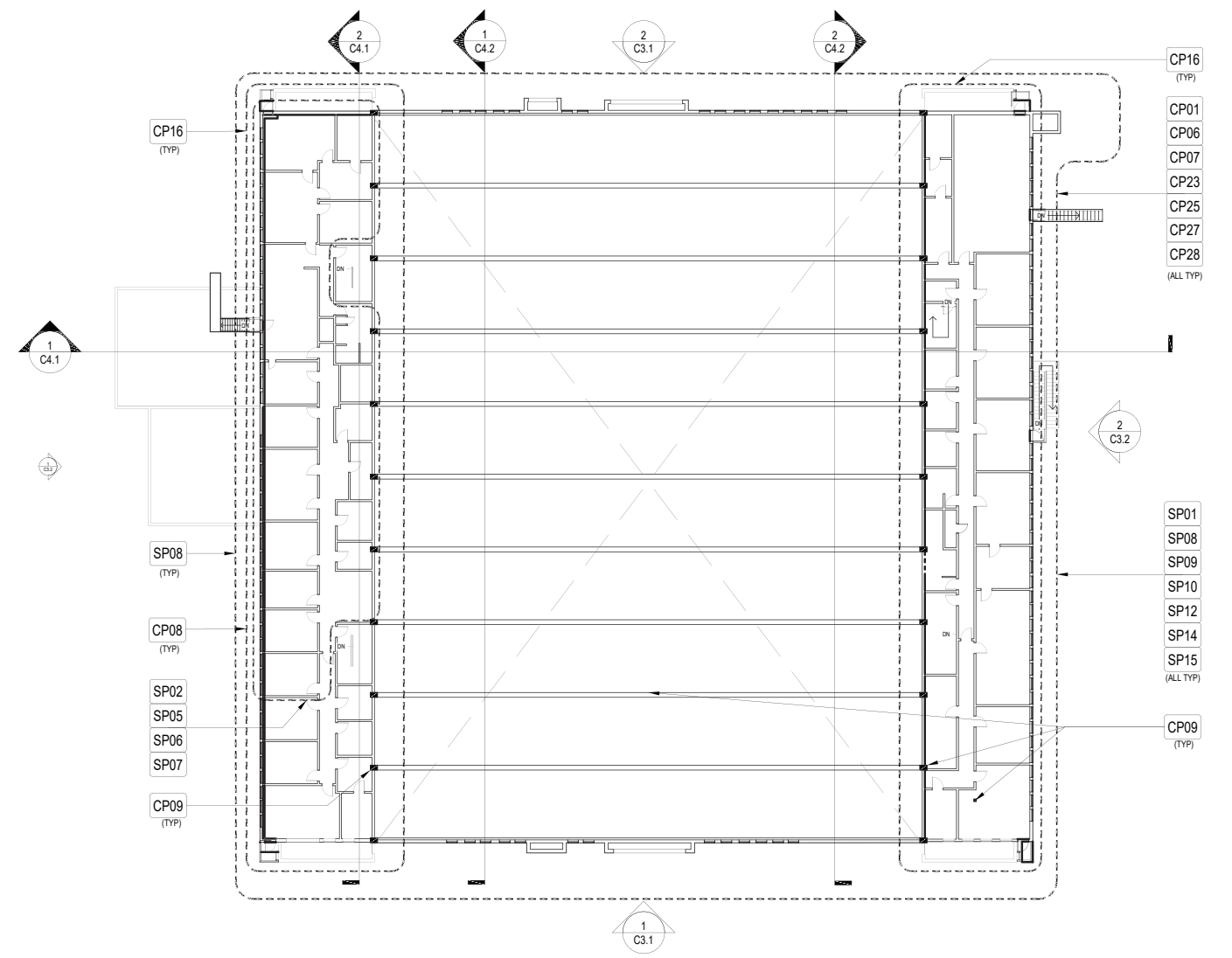

THIRD FLOOR PLAN
SCALE 1 : 500

C1.2

NOT FOR CONSTRUCTION

CONSERVATION PLANS
Hangar 11 | Scale - AS NOTED | Drawing No. C1.2

www.eraarch.ca
1.416.963.4497
E.R.A. Architects Inc.



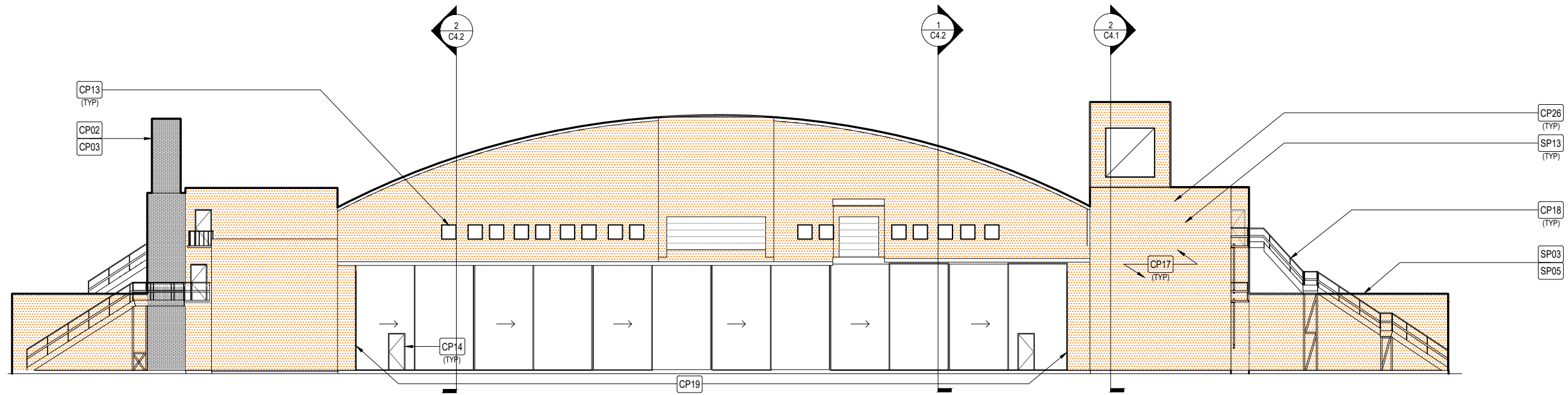

NORTH ELEVATION 2
SCALE 1 : 250 C3.1

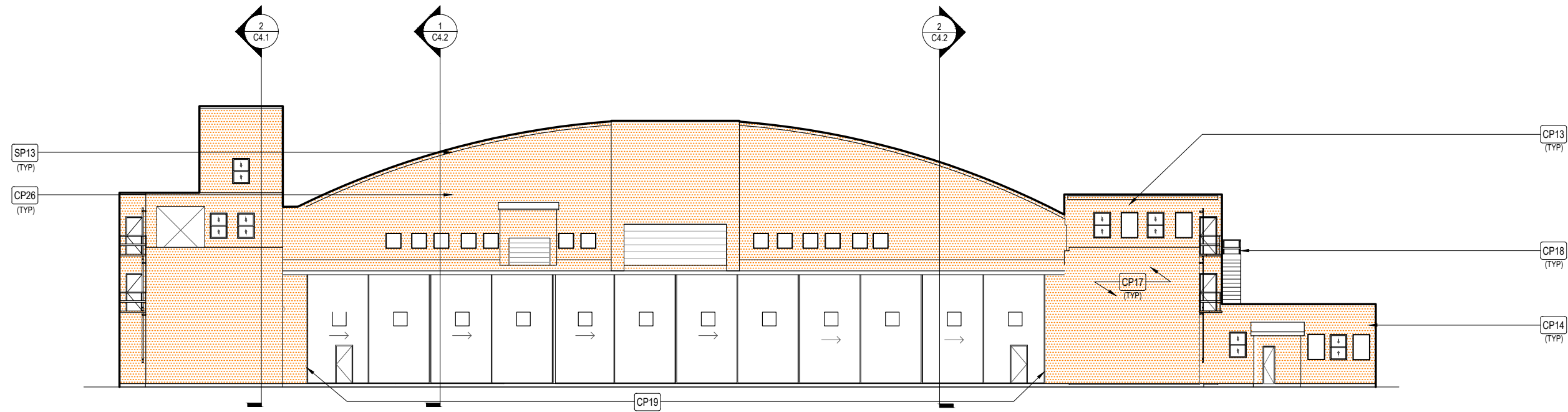

SOUTH ELEVATION 1
SCALE 1 : 250 C3.1

C3.1

WALL TYPE "W1"

NOT FOR CONSTRUCTION

CONSERVATION ELEVATIONS
Hangar 11 | Scale - AS NOTED | Drawing No. C1.3

www.eraarch.ca
1.416.963.4497
E.R.A. Architects Inc.



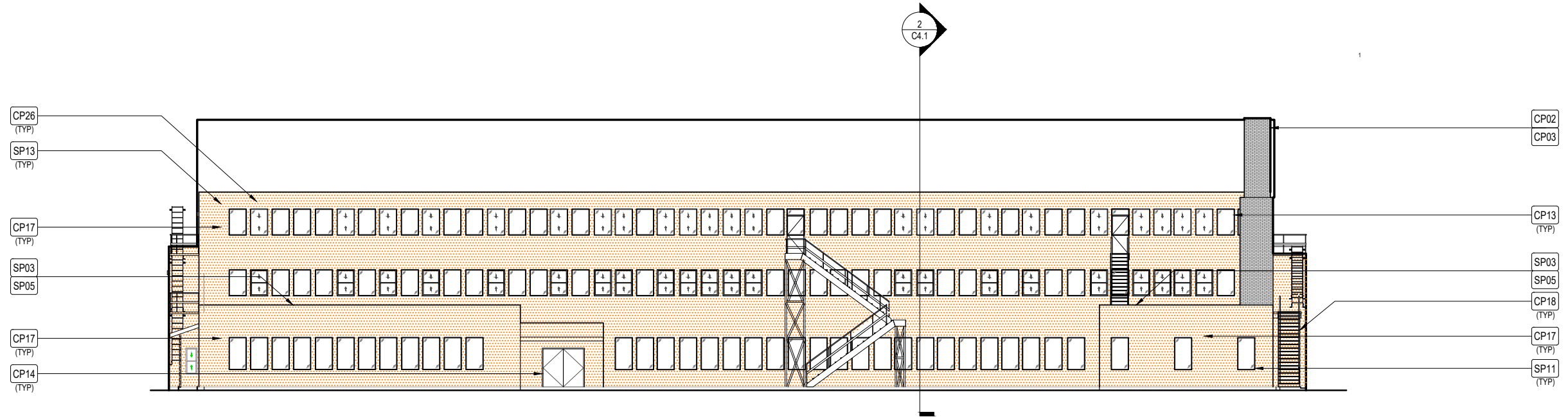

EAST ELEVATION 2
SCALE 1 : 250 C3.2

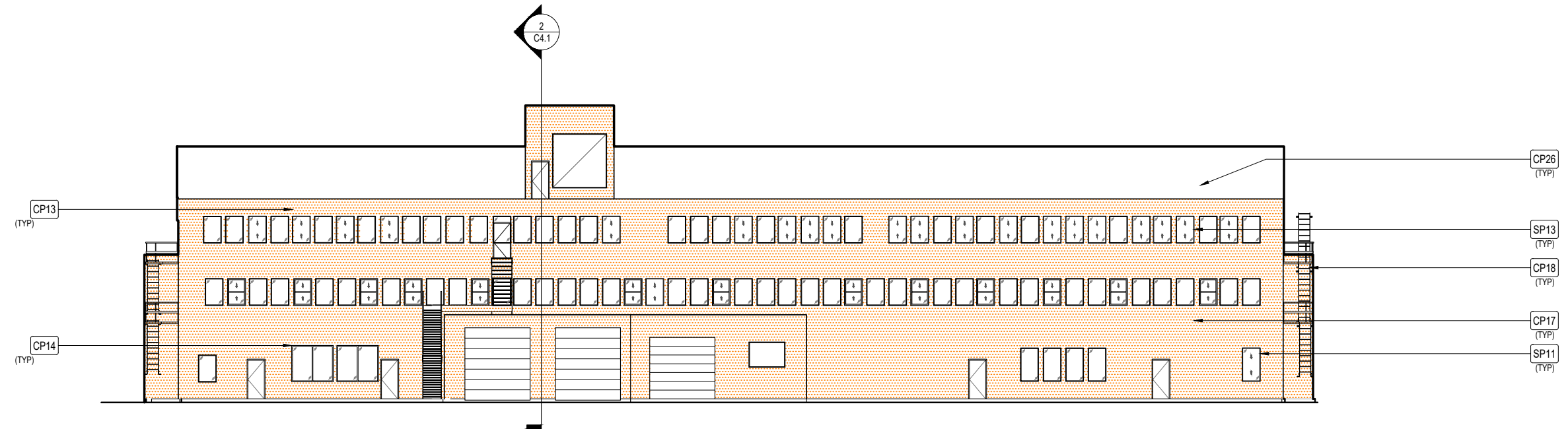

WEST ELEVATION 1
SCALE 1 : 250 C3.2

C3.2



NOT FOR CONSTRUCTION

CONSERVATION ELEVATIONS
Hangar 11 | Scale - AS NOTED | Drawing No. C3.2

www.eraarch.ca
1.416.963.4497
E.R.A. Architects Inc.



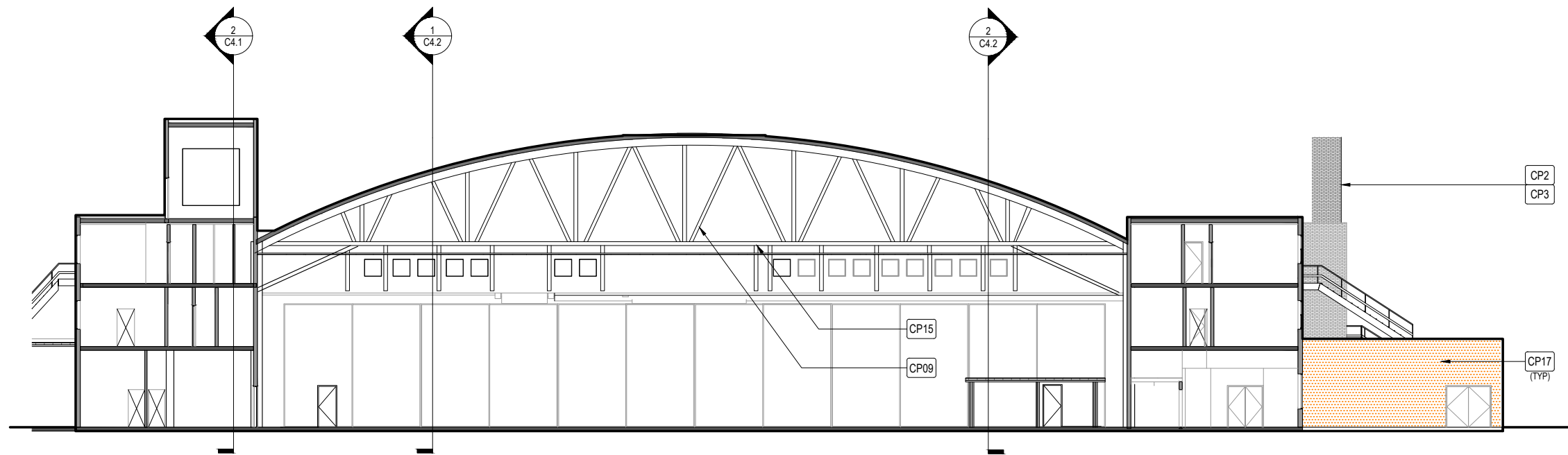

WEST TO EAST HANGAR BUILDING SECTION 2
 SCALE 1 : 250 C4.1

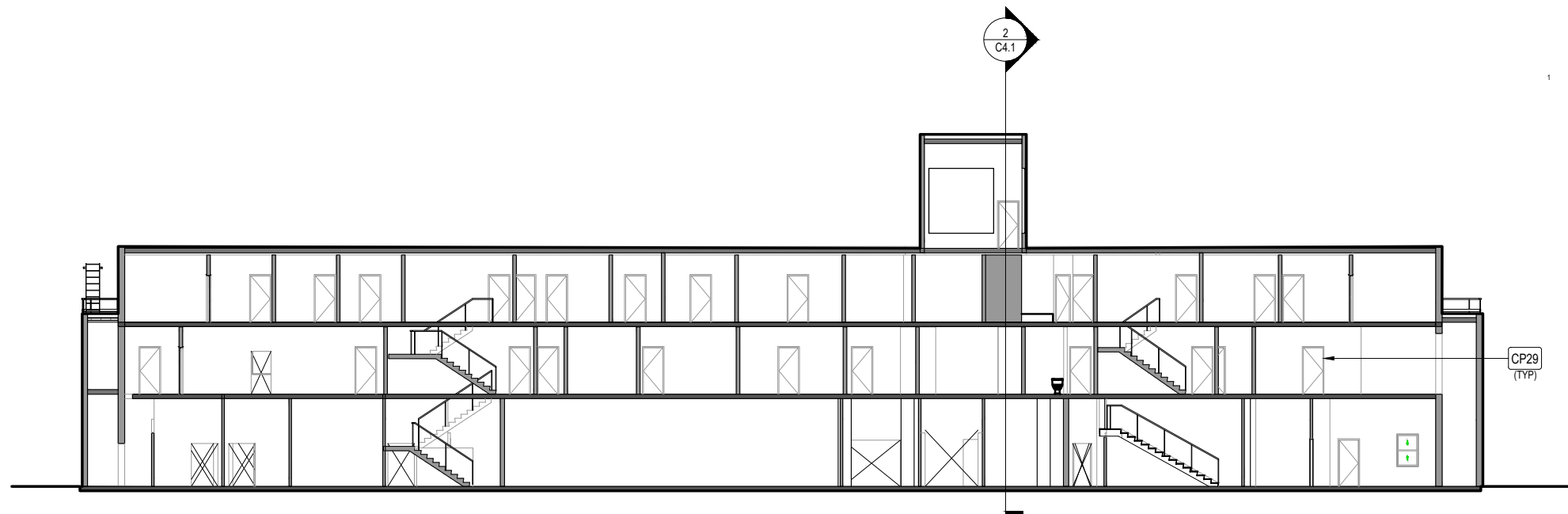

OFFICE / STAIR SECTION 1
 SCALE 1 : 250 C4.1

C4.1



NOT FOR CONSTRUCTION

CONSERVATION SECTIONS
 Hangar 11 | Scale - AS NOTED | Drawing No. C4.1

www.eraarch.ca
 1.416.963.4497
 E.R.A.Architects Inc.



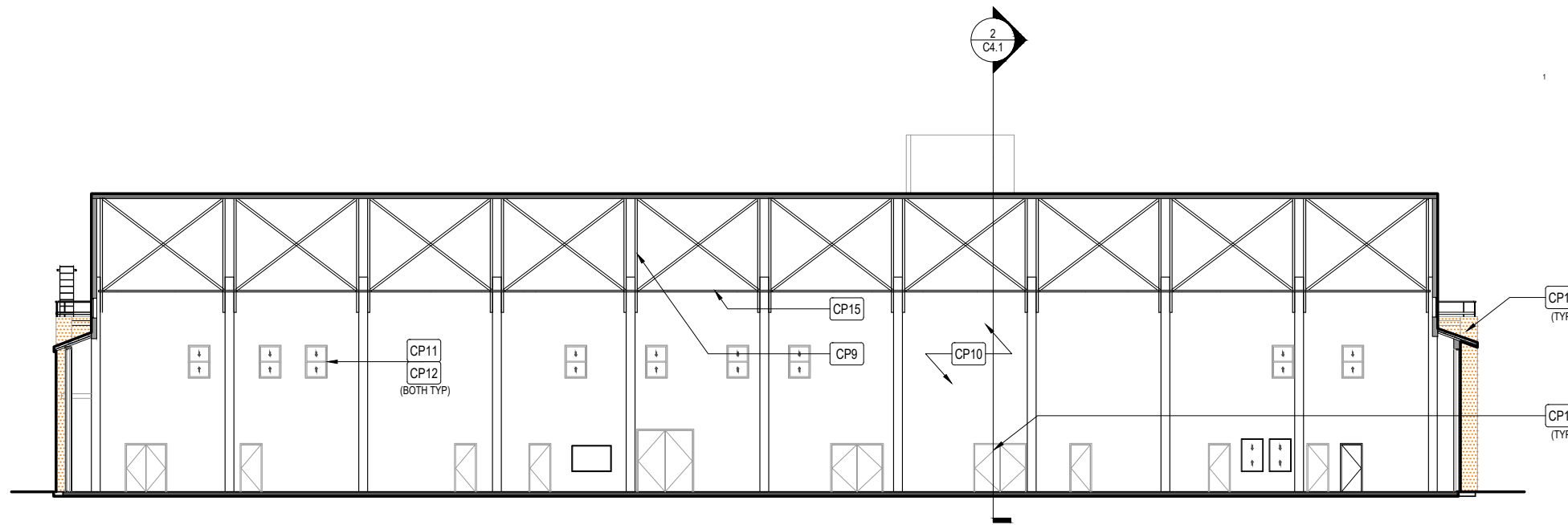

NORTH TO SOUTH HANGAR BUILDING SECTION 1
SCALE 1 : 250

2
C4.2

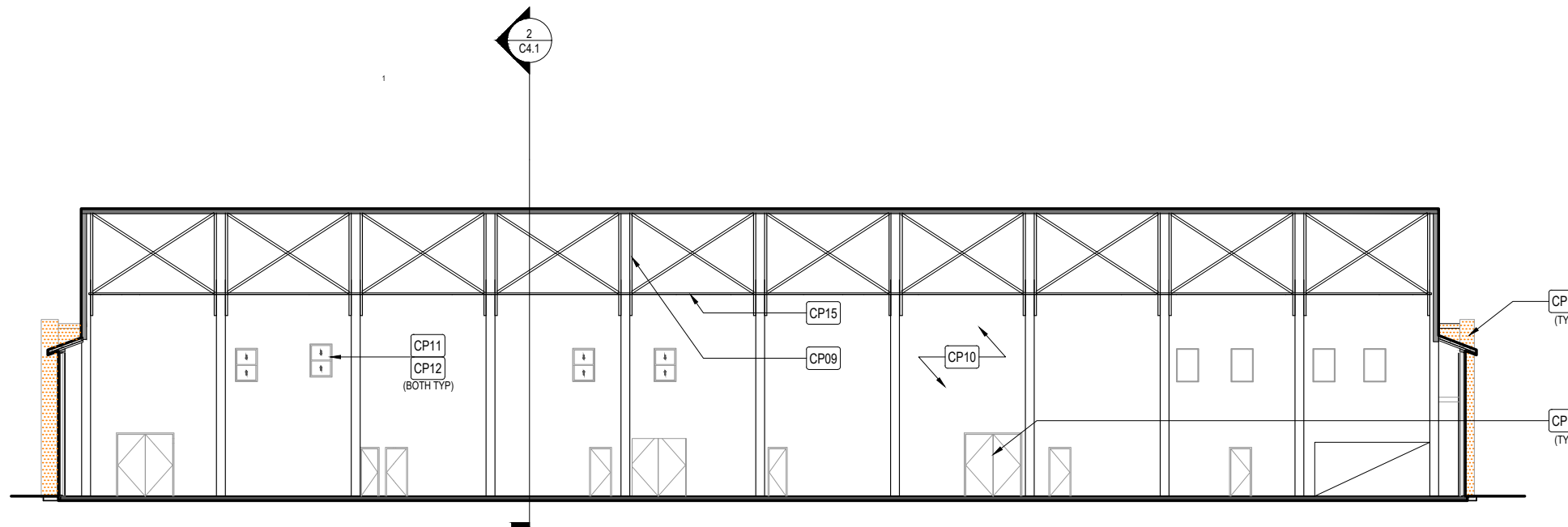

NORTH TO SOUTH HANGAR BUILDING SECTION 2
SCALE 1 : 250

1
C4.2

C4.2



WALL TYPE "W1"

NOT FOR CONSTRUCTION

CONSERVATION SECTIONS
Hangar 11 | Scale - AS NOTED | Drawing No. C4.2

www.eraarch.ca
1.416.963.4497
E.R.A. Architects Inc.



HANGAR 11 – BLATCHFORD ADVANCED ASSESSMENT & DOCUMENTATION: BUILDING CODE STUDY

PROJECT NO. 5719

FOR THE CITY OF EDMONTON



Suite 104, 10345 105th Street
Edmonton, Alberta T5J 1E8
Telephone: (780) 421-8060

1. Existing Building Code Review

1.1. Project Description

Built in 1942/43 by the United States Air Force (USAF), the Hangar 11 Building tells a multi-faceted story critically linked to WWII and the history of Edmonton's cultural and financial Growth and development. Located on the site of the Former municipal airport, the hangar was constructed as Part of the northwest staging route - a joint effort of The American and Canadian militaries that would ensure delivery of war materials to Alaska and the Soviet Union. It remains one of two remaining physical reminders of this Period when the city assumed a significant role in the Northwest continental defense.

The hangar building is comprised of an open central airplane hangar space, is roughly 46 m wide and 64 m long, and approximately 9.5 m clear to the underside of the roof structure. The main hangar consists of built-up laminated beams and bowstring timber trusses on wood columns with a concrete slab-on-grade. The north and south faces of the hangar are equipped with large rolling wooden doors. These are currently inoperable.

There are two ancillary office banks running length of the hangar on the east and west sides. Ancillary office banks and other areas appear to be wood frame post and beam construction with concrete slab-on-grade. The office banks are 3-storeys and are approximately 9 m wide x 64 m long. A set of loading bays (not original), totaling approximately 203 m², exists on the west side of the building. A single story of general office area protrudes from the east ancillary wing, and is approximately 171 m². Lastly, there is a boiler room at the north end of the east ancillary wing, totaling approximately 93 m².

Roofing consists of built-up roof membranes with gravel ballast on flat areas. Exterior Cladding consists of horizontal metal siding, finished white, but it is unclear if this is original cladding as renovations and building alterations have been made in the past and are largely undocumented.

Municipal Address: 11760-109th Street

Legal Address: Lot 2, Block 6A, Plan 9220135 Area 23B

Year of Construction: 1942/43 by the United States Air Force (USAF)

Height: 3 stories (under 18m)

Area: 4608.4 m² MAIN FLOOR (largest cross-sectional plan area)

Streets: 1 street, 109th Street

1.2. Applicable Building Code and Standards

1.2.1. Alberta Building Code

Model building codes set out in the National Building Code of Canada (NBC), which were first published in 1941; were in force at the time of the Hangar 11 construction.

For the purposes of this study, we use the 2019 National Building Code of Canada (Alberta Edition) (ABC) to assess the degree of compliance relative to today's standards.

1.2.2. NFPA 409, Standard on Aircraft Hangars

The first edition of fire protection recommendations for the construction and protection of airplane hangars were published by the National Board of Fire Underwriters (NBFU), now the American Insurance Association, in 1930.

NFPA 409 (2011 Edition) classifies a **Group I Aircraft Hangar** as having the following features:

- An aircraft access door height over 8.5m or less (*Hangar 11 main doors are ~6.5m tall*)
- A single fire area in excess of 3716 sqm (*Hangar 11 area is ~2975.8 m²*)
- Provision for housing n aircraft with a tail height over 8.5m (*Hangar 11 allows up to 9.2 m tail height*)
- As per NFPA 5.1.1. Group I hangars shall be Type I or Type II construction in accordance with NFPA 220 and NFPA 5000. As per NFPA 5000, 7.2.3.1 Type I and Type II construction shall be those types in which the fire walls, structural element, walls, arches, floors and roofs are of approved noncombustible or limited combustible materials (non-combustible).

Model building codes set out in the NFPA 409, which were first published in 1930; were in force at the time of construction. Any new code upgrades required by NFPA 409 would only be required should the building be continued to be used as an airplane repair and storage facility.

1.3. Energy Code

Building envelope and energy performance standards did not exist at the time of original construction, therefore are not considered as part of this existing building study.

1.4. Major Use and Occupancy

As per ABC 3.2.2.5. In determining the fire safety requirements of a building in relation to each of the major occupancies contained therein, the building height and building area of the entire building shall be used.

The existing Hangar 11 Building contained two major occupancies.

- Major Occupancy - Group F3 Low Hazard Industrial (Open Hangar Area + Storage Garage)

- Major Occupancy - Group D Offices (East and West Ancillary Wings)

1.4.1. Building Classification and Construction Requirements c/w Fire Separations Based on Building Classification(s)

Main Hangar Area: Reference ABC 3.2.2.83: Group F, Division 3, up to 3 Storeys

(DOES NOT CONFORM TO AREA or SPRINKLER REQ'S.)

- For an unsprinklered building, the building area shall be less than 1600sqm, if 3 stories in building height and facing one street. As measured from the Historic Building Record drawings, the main floor building area is 4608.4 m², exceeding the allowable area for this classification.
- A building of this classification is permitted to be of combustible or non combustible construction used singly or in combination.
- Floors, roof, mezzanines are to be 45min; Loadbearing walls, columns and arches supporting an assembly to be 45min FRR or be of non-combustible construction.
- As per clause ABC 3.2.1.7. A building shall be protected with an automatic fire suppression system if it has a fire compartment more than 2000sqm. The open area of the hangar is approximately 2975.8m².

1.4.2. East and West Ancillary Wings: Reference ABC 3.2.2.58: Group D, Up to 6 Stories, Sprinklered

(DOES NOT CONFORM TO SPRINKLER REQ'S.)

- The Hangar 11 building meets the criteria for building height and area, (building area is less than 6000sqm if 3 stories in building height). However, a building of this height and area is required to be sprinklered throughout.
- A building of this classification is permitted to be of combustible or non combustible construction used singly or in combination.
- Floors assemblies shall be fire separations with a fire resistance rating not less than 1hr.
- Roof assemblies shall have a fire resistance rating not less than 1hr and be constructed of non-combustible construction or fire retardant treated wood conforming to ABC 3.1.4.5.; Except where non-contiguous roof assemblies at different elevations, the roof assemblies are permitted to be evaluated separately to determine which ones are required to be constructed in accordance with (2)(c).
- Building shall be sprinklered throughout.

1.5. Component Fire Separations

Reference ABC Table 3.1.3.1. No Fire Separation with a fire-resistance rating is required between Major Occupancy Group F3 and Group D. Except that the area of the open hangar space exceeds the allowable fire compartment area.

Reference ABC 3.3.1.1. Fire Separations between adjoining suites in a business and personal services occupancies, are not required to have a fire resistance rating. Rating applies to the 2nd and 3rd floors of the ancillary wings, where multiple offices and support spaces are located.

Reference ABC 3.3.5.5. Notwithstanding the above, a repair garage and any ancillary spaces serving it, including waiting rooms, reception rooms, tools and parts storage and supervisory office space, shall be separated from other occupancies by a fire separation with a fire-resistance rating not less than 2hrs.

1.6. Exiting and Means of Egress

Reference ABC Table 3.3.1.5A and Reference ABC 3.4.2

In a floor area that is not sprinklered throughout, a minimum of 2 means of egress are required to serve each room or suite:

- Group D, for rooms or suites over 200sqm, maximum travel distance to an egress doorway is 25m.
- Group F, Division 3, for rooms or suites over 200sqm, maximum travel distance to an egress doorway is 15m.

With exception of the main Hangar Space, the remainder of the Group D occupancy areas contain rooms or suites under 200sqm. Rooms and Suites appear to have been provided with 2 means of egress, usually to an exterior exit ladder or stair case; and to at least one interior stair core.

However, the existing interior building staircases exit directly into the main hangar area (Group F3 occupancy) and not exit directly to the outdoors. The four interior staircases are located approximately 11.5 m to 18.5 m from the stair to the nearest exit to the outdoors.

1.7. Occupant Loads (Reference ABC Table 3.1.2.1)

Major Occupancy Classification	Occupancy Load	GFA of Building	Occupancy Load Calculation
Group F3 Low Hazard Industrial Occupancy	Aircraft Hanger (46 m ² /per person for occupancy calc.)	2975.8 m ²	65 Persons
Group D Business and Personal Services Occupancy	Offices (9.3 m ² /per person for occupancy calc.) Level 01 – 1329.6 m ²	3599.4 m ²	387 Persons

	Level 02 – 1134.9 m ²		
	Level 03 – 1134.9 m ²		
	Loading/Ancillary	303m²	n/a
	Washroom Areas	128.9 m²	n/a
	Level 01 – 39.86 m ²		
	Level 02 – 45 m ²		
	Level 03 – 44.04 m ²		
	Stairs	55 m²	n/a
Totals Occupant Load:			452 Persons

1.8. Washroom Fixture Requirements

Based on the requirements of ABC Table 3.7.2.2.C (Industrial Occupancy), we assume there are 65 building occupants, 33 males and 33 females. Therefore, the following quantities of fixtures would have been required:

- Male – 3 stalls (serving 26-34 persons)
- Female – 3 stalls (serving 26-34 persons)
- 2 Lavatories are required in each of the Male and Female washrooms

Based on the requirements of ABC Table 3.7.2.2.B (Business and Personal Services), we assume there are 387 building occupants, 194 males and 194 females. Therefore, the following quantities of fixtures would have been required:

- Male – 3 (for the first 50) + [1 (for each increment of 50 persons)] = 6 stalls
- Female – 3 (for the first 50) + [1 (for each increment of 50 persons)] = 6 stalls
- 3 Lavatories are required in each of the Male and Female washrooms

Given the area allocated to washrooms, the existing Hangar Building is likely in conformance with the total number of fixtures required.

1.9. Spatial separations and Exposure Protection

- 1.9.1.** *NFPA 409, Table 5.3.1 Clear Space Distances for Single hangar Buildings*, indicate that for Type I and Type II construction types, a minimum of 15m is required on all sides of a single hangar. As the adjacent development and property boundaries around the Hangar are developed in concert with the Blatchford Development, consideration of the required spatial separation and exposure protection shall be reviewed.

1.9.2. Limiting Distance Calculations & Minimum Construction Requirements for Exposing Building Faces

The current property boundaries are unclear as the site is contained within the property and zoning of the Municipal Airport Business Industrial Zone. Future re-zoning and property delineations for the surrounding adjacent context is not known at this time.

1.10. Fire Alarm and Detection Systems

The building is not sprinklered and it is unclear what Fire Alarm and Detection Systems were in place at the time of original construction.

1.11. Provisions for Fire Fighting

Facing 1 street: Facing 109th Street on the east side of the Hangar 11 building.

The other three elevations face private property – (historically, was part of the Municipal Airport Business Industrial Zone; now adjacent land is owned by Blatchford, City of Edmonton; and NAIT).

At present, the site is fenced and barriered with access only via 109th Street.

1.12. Barrier Free Design Requirements

The existing building does not meet barrier free design requirements, including:

- No barrier free access to the building is provided
- No barrier free means of egress is provided
- No passenger elevator is provided
- No barrier free / universal washrooms are provided

1.13. Flame Spread Ratings

The Hangar building is constructed of combustible construction. It is not known whether there are any coatings applied to the existing wood structure to mitigate fire exposure.

End of section.

2. Required Building Upgrades for Code Compliance

The existing hangar building is not in conformance with the 2019 Alberta Building Code standards. The building code synopsis in Part I, outlines issues where the type of combustible construction in relationship to its height, area and intended occupancy, do not meet current standards. The following study reviews possible strategies for the conservation of the existing hangar building and outlines the required building code upgrades needed to assess the costs for redevelopment and re-occupancy of the building.

In determining the minimum building upgrades required to meet the 2019 Alberta Building Code, there are limitations in understanding the potential scope due to the magnitude of possible design variations and methods of construction.

Therefore, the following study provides guidance in understanding the potential options for major occupancies; and multiple occupancy combinations, that can be considered given the type of combustible construction in relationship to the Hangar's height and area. This study also provides a minimum scope description for the primary base building code upgrades that would be required as part of any conservation project. Lastly, the National Research Council (NRC), provides guidance on the application of Part 3 of the National Building Code of Canada to existing buildings, which should be reviewed once the building's occupancy and program has been established for an adaptive re-use project, so that required code upgrades and costs can be more accurately determined.

2.1. Major Occupancies:

We investigated two strategies for classifying the Hangar 11 building, given its type of construction, its height and area:

- Building's Height -3 stories
- Area - 4608.4 m²
- Construction Type - Combustible Wood Construction

2.1.1. Strategy 1: Entire Building is classified as Group D (permitting combustible construction):

In considering a single occupancy for the Hangar 11 building, the only viable classification is 3.2.2.58 Group D, Up to 3 Storeys, Sprinklered. At minimum, the building will need to be fully sprinklered with an automatic fire suppression system. A building of this classification is restricted to a maximum of 6000 sqm. It is important to note, that the code restricts a building classified as 3.2.2.58, from containing a Group A, Division 2 occupancy. However, given the building's construction type, the height and area, there are no other allowable Group A, C, E or F Occupancies.

2.1.2. Strategy 2: Create Fire Walls with a Fire Resistance Rating of 2 to 4 hrs to isolate the Hangar Building Portion from the Ancillary Wings. (The Resulting Building would then be considered 2 or 3 separate buildings):

The introduction of fire walls to segregate portions of the building, allow us to consider the height and area of each portion as a stand-alone building; for which only one primary entrance would be required within proximity to 109th Street. This approach provides greater flexibility in determining allowable major occupancy combinations and satisfies the City's desire for various future adaptive re-use development scenarios.

As per *Article ABC 3.1.10.2. Rating of Firewalls*, the following apply:

- A Firewall separating Group E – Fire Separation of non-combustible construction having a fire resistance rating (FRR) of not less than 4 hrs.
- A Firewall separating a building other than Group E – Fire Separation of non-combustible construction having a FRR of not less than 2 hrs.
- A firewall permitted to have a fire-resistance rating not more than 2h need not be constructed of masonry or concrete, provided
 - a) the assembly providing the fire-resistance rating is protected against damage that would compromise the integrity of the assembly, and
 - b) the design conforms to *Article ABC 4.1.5.17. (See Note A-3.1.10.2.(4).)*
- Given that the structure is of combustible construction, fire walls would need to extend beyond the roof structure.

For the purposes of this study and costing analysis, we assume that the three (3) primary areas within the Hangar will also inform the location for two (2) fire walls, as follows:

- a) Building A – East Ancillary Wing (839.5 m²); with Fire Wall b/w A + B.
- b) Building B – Hangar Space (2975.8 m²); with Fire Wall b/w B + C.
- c) Building C – West Ancillary Wing (793.1 m²).

ABC Table 3.1.3.1, at the end of this subsection, outlines the fire resistance rating of the required fire separations between major occupancies considered for the Hangar 11 building areas, as defined above.

2.1.3. Component Fire Separations

Typically, fire separations having a fire resistance rating are required for the segregation of the building into fire compartments no larger than 2000sqm. The existing area of the main hangar space is 2975.8 m² and exceeds this maximum allowable area. If there is an intent to allow the main hangar space to remain as a single fire compartment larger than 2000sqm, special approval and an alternate approach to code compliance will likely be required by the authority having jurisdiction.

Major Occupancy Fire Separations (Reference ABC Table 3.1.3.1.)

Major Occupancy (all potential occupancy classifications must allow combustible construction and must meet the maximum allowable areas defined for a building having one street accessible by fire truck.)	Minimum Fire-Resistance Rating of Fire Separation, (h)						
	Adjoining Major Occupancy						
	A1	A2	A3	C	D	E	F3
A1 – Assembly (production and viewing of the performing arts)	0	1	1	1	1	2	1
A2 – Assembly (not otherwise classified in Group A)	1	0	1	1 (*)	1 (**)	2	1
A3 – Assembly (Arena Type)	1	1	0	1	1	2	1
C – Residential	1	1 (*)	1	0	1	2 (***)	1
D – Business and Personal Services	1	1 (**)	1	1	0	0	0
E – Mercantile	2	2	2	2 (***)	0	0	0
F3 – Low Hazard Industrial	1	1	1	1	0	0	0

Note * Where the building is constructed in accordance with Article 3.2.2.50., a fire separation with a 2h fire-resistance rating is required between the Group C and Group A, Division 2 major occupancies.

Note ** Where the building is constructed in accordance with Article 3.2.2.58., a fire separation with a 2h fire-resistance rating is required between the Group D and Group A, Division 2 major occupancies.

Note *** In a building not more than 3 storeys in building height, if not more than 2 dwelling units are contained together with a Group E major occupancy, the fire-resistance rating of the fire separation between the 2 major occupancies need not be more than 1h.

2.2. Heavy Timber Construction

Article ABC 3.1.4.7. Heavy Timber Construction, suggests that if combustible construction is permitted to be used, and is not required to have a fire resistance rating more than 45 min, heavy timber construction is permitted to be used in lieu.

Furthermore, Article 3.1.4.7 provides the requirements for the combustible construction of walls, floors, roofs, etc. that are constructed of heavy timber. Exposure and examination of the existing structure will be required to verify that the materials and thicknesses used, are code compliant, meeting a fire resistance required as per 3.1.4.7. In the event that the construction of the Hangar 11 building does not meet current standards, an alternate path to achieve code compliance may need to be discussed with the AHJ.

2.3. Exterior Cladding

Not less than 90% of the exterior cladding on each exterior wall shall consist of non-combustible cladding; or a wall assembly that satisfies the criteria of Sentences 3.1.5.5.(3) and (4) when tested in accordance with CAN/ULC-S134, “FireTest of Exterior Wall Assemblies.” (See Appendix A.) (See also A-3.1.5.5. (3) and A-3.1.5.5. (4) in Appendix A.)

2.4. Energy Code

The application of the National Energy for Buildings (NECB) 2017 applies to new construction only, therefore the historic restoration of Hangar 11 would be exempt from these requirements. However, the City of Edmonton may have specific targets for energy efficient design that shall be considered in a restoration/adaptive re-use project. The City may also wish to consider commissioning an energy model to help determine target values for the building envelope and building system design.

2.5. Exiting and Means of Egress

2.5.1. Exits

Reference *Article ABC 3.4.2.1*. Every space intended for occupancy shall be served by a minimum of 2 exits so that one doorway can provide egress if the other doorway becomes inaccessible to the occupants due to a fire which originates in the room or suite, for where the following applies:

- The room is intended for an occupant load greater than 60 persons
- The travel distance to an egress doorway is more than 25m
- For a building that is sprinklered throughout, the area of the room or suite is more than the value in *ABC Table 3.3.1.5.B*.

The existing interior stair cores exit into the main hangar space. Exit stairs will need to provide a path a travel to safely exit the building. Depending on the occupancy classification and the rating required for the fire separations of exits, there will need to be modifications required to the interior staircases. In addition, interior modifications to create rated exit corridors, allowing direct access to the exterior may be required. Stairs shall meet the requirements of 3.4.6. *Types of Exit Facilities*.

The existing exterior stairs are in varying states of decay and disrepair. The reconstruction of these exterior exits may or may not be required for code reasons; however, as original components of the building, we feel they should remain. At minimum, all four (4) exterior stairs and three (3) exterior ladders shall be re-constructed around the perimeter of the building.

Depending on the occupancy classification and on the desired interior partition locations, additional new rated exit stairs may be required to accommodate a second means of egress from a suite.

2.5.2. Fire Separation of Exits

Stairs and exiting corridors shall be protected by fire separations with a fire- resistance ratings as per the requirements of subsection 3.2.2.

2.5.3. Travel Distance

Article ABC 3.4.2.5. states that, for a building that is sprinklered throughout, the maximum travel distance is:

- 40m in a business and personal services occupancy.
- 45 m in a floor area that contains an occupancy other than a high-hazard industrial occupancy, provided it is sprinklered throughout,

Once the Hangar 11 building is fully sprinklered, throughout, and path of travel is defined, the distances to the nearest exits from the main hangar space, shall meet the required travel distance requirements.

2.5.4. Exit Width

The minimum exit width shall be determined by the requirements of ABC 3.4.3.2 Exit Width and by the Occupant Load.

2.6. Fire Alarm and Detection Systems

Reference ABC 3.2.4.1. A building installed with an automatic sprinkler system is required to have a fire alarm system. A single or 2-stage fire alarm system is required.

2.7. Occupant Load

The determination of an occupant load is contingent on the type of occupancy classification and the specific plan layout of the building. Article ABC 3.1.17.1 and Table 3.1.17.1 define the maximum occupant load based on an area per person, for the type of an occupancy desired; or by the following:

- The number of seats in an assembly occupancy having fixed seats,
- 2 persons per sleeping room in a dwelling unit, or
- The number of persons for which the area is designed, but not less than that determined from Table 3.1.17.1. for occupancies other than those described above, unless it can be shown that the area will be occupied by fewer persons.

Once the use and program for the conservation /adaptive re-use of the Hangar 11 building has been established, occupancy loads can be calculated with a greater degree of accuracy.

2.8. Washroom Fixture Requirements

Without a clear understanding of the occupant load for the building, we are unable to determine the quantity of washroom fixtures required, as this calculation will vary greatly depending on the type of occupancy and the occupant load for the given area. All washrooms are required to be upgraded to meet the following:

- Provide new code compliant washrooms (all new fixtures, finishes, mechanical and electrical services) will be required.
- Washrooms shall meet the requirements of ABC 3.8 Barrier Free Design and the City of Edmonton Access Design Guidelines.

2.9. Barrier Free Requirements

The existing Hangar 11 building does not meet barrier free requirements. At minimum, the following building upgrades are required to provide a barrier free access:

- Provide power door operators at entrances, as per *Article 3.8.2.7*.
- A Barrier free path of travel for means of egress shall be provided as per *Article 3.8.3.2*, including provision of:
 - Passenger Elevators meeting the requirements of *3.8.3.7 Passenger Elevating Devices*. Depending on the final occupancy, the configuration of fire walls and the intended level of service required, a minimum of two elevators shall be considered to provide redundant service; or to serve each of the ancillary wings.
 - Ramps, shall meet the requirements of *Article 3.8.3.5 Ramps*.
- Barrier free or universal washrooms shall be provided.
- Barrier Free parking stalls shall be required. Parking requirements and potential parking lot location are not yet determined and will be contingent on the future zoning and land use.

2.10. Flame Spread Ratings

Reference ABC 3.1.4.1. The flame-spread rating on any exposed surface of foamed plastic insulation, and on any surface that would be exposed by cutting through the insulation in any direction, shall be not more than 500. Refer to 3.1.4.2 for protection of foamed plastics requirements; and to 3.1.4.7. Heavy Timber Construction (see above).

Flame spread ratings for all interior finishes, ceilings, glazing and skylights, shall not be more than 150 and shall confirm to Article ABC .1.13.2. and Table 3.1.13.2.

End of section.

3. Summary of Scope of Work Required for Compliance with ABC 2019

As expressed throughout this study, there are several possible design variations and methods of construction that could be considered in a conservation/adaptive re-use project for the Hangar 11 building. As such, the following scope of work is not exhaustive of all code upgrades that may be required for full occupancy, but provides a minimum scope description for the primary base building code upgrades that would likely be required as part of any conservation project.

Design and construction contingencies are added to the estimated budgeted amounts and are intended to account for the potential work that we are unable to determine at this time.

- **Automatic Sprinkler System:** The building shall be provided with an automatic sprinkler system throughout, as per ABC 3.2.5.12. *Automatic Sprinkler Systems*. As per 3.2.5.8, A standpipe system is not required.
 - This item is included in CP-25, *Refer to Class D Estimate, Appendix B*.
- **Fire Alarm System:** Install a 2-stage fire alarm system.
 - This item is included in CP-25, *Refer to Class D Estimate, Appendix B*.
- **Combustible Construction Wood Treatment:** The existing wood supporting structure (columns, beams, and roof trusses) shall be treated with clear intumescent coating. Depending on the fire resistance rating of any required fire separations; and depending on a detailed analysis of the heavy timber construction elements, additional protection measures as discussed in report subsection 2.2.
 - This item is included in CP-09, *Refer to Class D Estimate, Appendix B*.
- **Fire Wall Strategies:** For the purposes of this ABC study, the fire wall strategy assumes that the three (3) primary areas within the Hangar will inform the location for two (2) fire walls, with a fire separation of 2 hr between the main hangar space and the ancillary wings.
 - This item is included in CP-28, *Refer to Class D Estimate, Appendix B*.
- **Exterior Cladding:** The exterior cladding shall be of non-combustible material (metal or fibre reinforced concrete siding).
 - This item is included in CP-17, *Refer to Class D Estimate, Appendix B*.
- **Exit Stairs:**
 - Each of the four (4) existing interior stairs shall be modified to meet the requirements of 3.4.6. Types of Exit Facilities, and are to be constructed as fire separations, having a fire resistance rating as required for the determined occupancy classification.
 - The existing exterior stairs are in varying states of decay and disrepair. The reconstruction of these exterior exits may or may not be required for code reasons; however, as original components of the building, we feel they should remain. Therefore, at minimum, all four (4) exterior stairs and three (3) exterior ladders shall be re-constructed around the perimeter of the building.

- This item is included in *CP-28*, Refer to Class D Estimate, Appendix B.
- **Passenger Elevator:** A minimum of two new passenger elevators,
 - This item is included in *CP-28*, *Refer to Class D Estimate, Appendix B*.
- **Washrooms:** Provide new washrooms throughout. The existing Hangar building has approximately 128.9 m² of washroom area. For the purposes of the conservation/adaptive re-use study we allow new fixtures, finishes and all mechanical and electrical services at a unit rate for 128.9 m².
 - This item is included in *CP-27*, *Refer to Class D Estimate, Appendix B*.
- **Seismic + Structural Upgrades:** This scope of work will be defined as part of the structural analysis to determine the capacity of the exiting structure to withstand current seismic, wind and snow load requirements.
- **Exclusions:**
 - Utility upgrades for water service to serve new plumbing fixtures and the automatic fire suppression system flow and pressure requirements will need to be determined.

End of section.



Engineers

Hanger 11 Blatchford

Structural Assessment

11760 – 109 Street NW
Edmonton, Alberta

September 2019
RJC No. EDM.112311.0003

Prepared for:

GEC Architecture
104, 10345 – 105 Street NW
Edmonton AB T5J 1E8

Prepared by:

Read Jones Christoffersen Ltd.
100, 17415 - 102 Avenue NW
Edmonton AB T5S 1J8



Table of Contents

1.0	INTRODUCTION	1
2.0	VISUAL CONDITION ASSESSMENT (OF BUILDING AREAS)	1
2.1	Main Hangar Construction (Central Portion)	2
2.2	East And West Ancillary Spaces	4
2.3	Building Exterior	5
3.0	TESTING PROGRAM	6
3.1	Moisture Testing	6
3.2	Foundation Testing	7
4.0	PRELIMINARY STRUCTURAL ANALYSIS	9
4.1	Lateral Analysis	9
4.2	Roof Design Load Analysis	10
4.3	Summary of Load Impacts	10
5.0	RECOMMENDATIONS/COSTS	10
5.1	Stabilization (Short-Term Preservation)	10
5.2	Conservation (Long-Term Re-Occupied Building)	11
5.3	Considerations For Contemplated Repairs	12
6.0	SUMMARY	13



1.0 INTRODUCTION

RJC was asked to prepare an updated structural condition assessment of the Blatchford Hangar No. 11 located on the east side of the former City Centre Airport in Edmonton, Alberta. The review was a follow-up to a review completed by RJC with S2 Architecture in 2017; refer to that report for additional information.

The purpose of the current review, as requested by GEC Architecture, was to complete:

- A visual condition assessment of the present condition of the structure, including changes in condition from 2017.
- A small testing program, including moisture and foundation testing, to better understand the structure's condition.
- A preliminary load analysis for both lateral and snow loads. The purpose was to compare the original and current design codes, in anticipation of potential upgrading requirements.
- Provide estimates of probable costs for:
 - First, for maintaining the structure in short term to limit further deterioration while development options are considered (hereafter referred to as Stabilization).
 - Second, for renovating/upgrading the existing structure to suit proposed redevelopment of the existing facility (hereafter referred to as Conservation plan).

The following report outlines the work completed.

2.0 VISUAL CONDITION ASSESSMENT (OF BUILDING AREAS)

The condition assessment was limited to visual observations of accessible areas only. No testing or dismantling of any finishes occurred during our evaluation, except for the foundation testing as noted below. A design review was beyond the scope of this project and no calculations were performed. Structural drawings were not available for review.

There is currently no power to the building, so the reviews were carried out using hand held flashlights and limited natural light from windows. Several areas contained large accumulations of debris, which restricted our ability to access and observe the building structure.

In short, the structure of the building is in poor condition, with several areas in very poor condition. The structure has deteriorated further since 2017 due to its on-going exposure to weather, water infiltration, lack of heat and other factors. It is likely portions of the structure are structurally compromised based on the conditions observed during the review.

The building structure can be segregated into three areas: the main hanger, the ancillary building on the east and west sides of the main hanger and the exterior walls. The condition observed were as follows:

2.1 Main Hangar Construction (Central Portion)

- In general, the main hangar wood framing has deteriorated further since 2017. We observed greater extents of staining of the wood and extensive areas of softened and darkened framing throughout.
- The wood roof framing (roof deck, joists, trusses and the ceiling support framing) shows signs of water infiltration and biodegradation. In general only a small portion of the hangar roof (<5%) was safely accessible for review along the main walkway through the attic space.
 - The glulam/timber trusses appeared generally in a similar condition as 2017; however, there was more exposure to moisture on the glulam members.



Photo 1: Truss top – signs of water infiltration

- RJC observed evidence of deterioration of the roof deck boards and joists, with the poorest conditions being concentrated at west/east ends of hangers.
- At one glulam truss chord, RJC observed what appears might be signs of glue deterioration between the laminations of the glulam members. Further investigation would be needed to confirm this observation since delamination of the glulam members (should it be present) would significantly impair the hangar truss load carrying capacities.

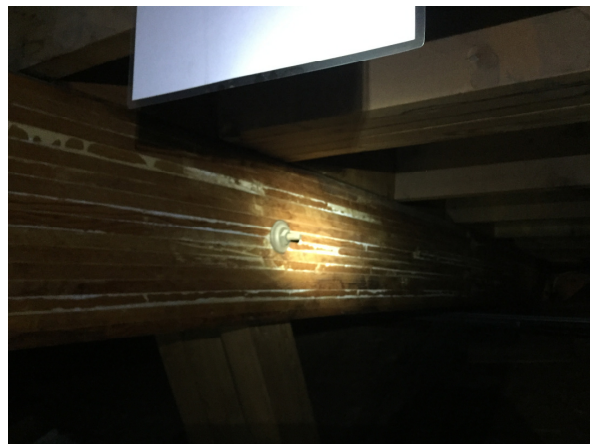

Photo 2: Chord – Potential glue deterioration

- The hangar walls at the east and west sides of the hangar are more deteriorated than in 2017. The deteriorated condition is considered important as RJC believes they are load bearing and provide lateral stability to the building. They were observed to be in a highly saturated condition and were mushy (wet rot). There was also significant signs of biodegradation on the surface. It is likely these walls have lost structural capacity.



Photos 3 and 4: Hanger Walls – Signs of Deterioration

- The wood columns that support the trusses on east/west side of hangar were observed to be in a wet condition and soft in some locations, which would suggest the presence of wet rot in the columns.
 - One column was observed to be so significantly deteriorated that a screwdriver could penetrate into column at its base (on west wall, near north end). There was also observed loss of material at the column base. This loss of material at the column's base is of significance as it suggests a loss in structural capacity.



Photo 5: Damaged Column – Hole at Bottom where screwdriver could go in

- Finishes adjacent to the columns were observed to have significant bio-deterioration and mold. Portions of these finishes were observed to be so deteriorated as to have to only residual strength (effectively “mush”). There is a high probability of more column damage currently being hidden by the finishes.
- The ends of the trusses braces, visible from the ancillary buildings, was observed to be soft at their ends with very high moisture readings. These braces also showed early signs of biodegradation and have worsened since 2017. Their deteriorated condition suggests that they are structurally weakened.
- The access into the truss attic space (on the SW side) is significantly wetter than previous and appeared to be soft. The area was deemed unsuitable to be used for access (unlike in 2017), so access was only available from one location along walkway.
- The Hanger ceiling (at underside of bottom chord of trusses) is more discoloured, has more signs of biodegradation, and has failed in more areas.
- The main slab area appears generally in same condition as 2017.

2.2 East And West Ancillary Spaces

- In general, the condition of the ancillary superstructure framing has deteriorated further since 2017. Some of the areas are deteriorated to point where it is likely the structure is compromised beyond repair, especially the northern half of the western ancillary floors and roof.
- The superstructure (post and beams), where visible, had a greater number of locations with exposure to significant moisture on or directly adjacent to the framing. It appeared there was limited bio-degradation, but moisture reading in this portion of the structure will still quite high.
- Joist framing, where visible, was observed to be dark in color, wet, and exhibited significant deflections. It is anticipated a good portion of the joists are likely structurally compromised and beyond repair.



Photos 6 to 7: Ancillary Framing



Photos 8 to 9: Ancillary Framing – Damaged Finishes due to water Infiltration

- The eastern ancillary area had more localized deterioration since 2017. It appears there is increased evidence of water and biodegradation, especially for the floor/roof areas directly adjacent to the hanger (within a zone approximately 6 feet in width running parallel to the east wall of the hangar) likely caused by water infiltration down dividing wall.
- In general, the finishes had more soft spots, staining, and signs of mold/bio-deterioration, including fallen ceiling areas; wet, stained, or mold-covered walls; signs of organics; and soaked finishes (carpet growing organic material, black/ponding water on floors/roof, and damaged flooring). It is likely the materials covering the structure are contributing to the structure's deterioration.
- The main floor slabs generally appear to be in same condition. In areas where wood is placed above the floor, there are more soft spots and more warping of the floor, as well as signs of ponding.

2.3 Building Exterior

- In general, the condition of the building exterior has deteriorated further from the 2017 condition. More areas of the siding have fallen off or been damaged, exposing the framing below to continued weather and subsequent damage.



Photo 10: Exterior: General condition



- Roof areas were not visible from our review, but likely has deteriorated further given the increased water infiltration (especially on the western ancillary building and the ends of the curved hanger roof). As a consequence of the lack of performance of the roofing, it is expected deterioration of the structure will exponentially increase with time.
- The framing of the small overhangs above the overhead doors (on the north and south walls of the hanger) was observed to be more deteriorated than the previous conditions recorded in 2017.
- The exterior brick chimney appears to be tilting. It is not known if this is worse, but appears to be poor and potentially damaged.
- Stairs and miscellaneous framing on outside is still considered unsafe and will require full replacement for safety reasons.

3.0 TESTING PROGRAM

A small testing program was implemented to help further the understanding of the structure's condition. Moisture testing was completed on the wood structure throughout the building and an excavation test was completed to expose and test the existing concrete foundation. The testing observations were as follows.

3.1 Moisture Testing

RJC randomly selected locations throughout the building to complete moisture testing of both the structure's members and the adjacent finishes. It is important to note at time of review there was significant moisture in the building (including active ponding in some areas), due to recent rains in Edmonton.

Measurements were taken using a hand-held GE Protimeter Moisture meter in July 2019. The instrument uses two small prongs that give approximate values of moisture when placed into the structure/finishes. In general, values for dry conditions should be around 10 to 15%, with very wet areas registering in the 80% range as a maximum. The testing information obtained was as follows:

Location within Building	Area of Structure Tested & Description of Condition	Moisture Reading
Main Truss Columns in Hanger Area	Central West Column - location of significant moisture. Soft surface in area exposed and signs of biodegradation.	60%/77% in column, 80% in walls adjacent
	West Wall Column – same condition as above	35%/54%/71% in column, 75% in walls adjacent
	East Wall Columns – 2 locations. Same condition as above	14% (at 2 nd floor)/27%/15% (at 2 nd floor)/25% in column 38%/64%/72% in wall
Truss in Hanger	Locations in sawn web members, in glulam chords. See previous section for description of condition found.	8-11% (in dry areas), 28%/34/41% in wetter areas
Roof Framing in Hanger	Locations in decking or joists. See previous section for description of condition found.	10% (in dry areas), 32%/55% in very wet areas



Ancillary Framing	Several locations were tested. Conditions included actively wet areas. Significant deterioration found on some areas.	10% (in dry areas), 15-80% in very wet areas. Several high readings found in western ancillary and in west portion of eastern ancillary.
-------------------	-----------------------------------------------------------------------------------------------------------------------	------------------------------------------------------------------------------------------------------------------------------------------

In general all areas of the structure had locations with elevated moisture readings (some were significantly high). These elevated levels were not surprising given the visual signs of water and the musty smell throughout the building. It is clear water has been in the building for an extended period and infiltrated structure and finishes alike.

The concern with high levels of moisture is twofold: it is a sign of bio-deterioration already happening with the members and is also a condition that lead to more rapid deterioration of the members that are currently not deteriorated. It also implies there could be significant damage to the structure that is hidden behind finishes and which could not be observed during the review.

In summary, the building has a very significant moisture problem and the structure's condition will continue to get worse unless the moisture is addressed by drying the structure out and providing a suitable building envelope to prevent further water infiltration. There may also be movement of the structure caused by re-drying of the wood given how wet it is, which will change shape due to the re-established conditions and could affect current and/or newly added finishes/envelopes.

3.2 Foundation Testing

The purpose of the foundation testing was to determine what the foundation type and its condition in one location. In mid-July 2019 RJC, Carlson Construction and Tetra-Tech concrete testers exposed one of the footings under the primary truss columns. The scope of work included removal of a 2.1 m x 2.1 m area of the slab on the hanger side of the column, excavating down to top of footing below and exposing the foundation. The structure observed was as follows.

The truss column is supported by a concrete pyramid-shaped pilaster, which is supported below by a small footing. The top of the footing is located approximately 1.2 m below the slab elevation. The footing was at least 200 mm thick and roughly 300 mm wider than the pilaster at the base, but the extent and depth of the footing could not be fully exposed due to very wet conditions. Limited reinforcing was found when tested, although again was difficult given the wet conditions and rough top surface. The slab construction found is roughly 200 mm to 250 mm thick on generally loosely compacted clay subgrade.



Photos 11 and 12: Foundation Testing and Exposed Foundation

In general, the concrete on the footing and the pilaster was found to be in fair condition. Tetra-tech completed two 100 mm cores in the footing. The cores were tested for concrete strength and were found to be 35 and 50 MPa (testing information below). When reviewed visually, the concrete at the one footing appears to be in fair condition for the location exposed.

COMPRESSIVE STRENGTH OF INTACT ROCK CORE SPECIMENTS												
ASTM D7012												
Project:	Hangar 11 Coring					Client:	Read Jones Christoffersen Limited					
Project No.:	ENG.EMAT03463-22					Supplier:	N/A					
Test Location:	Southwest Footing					Specified Strength:	N/A					
Core Locations:	3279.1	Approximately 15.0 m E and 0.5 m N of SW corner of the interior slab of Hangar 11										
	3279.2	Approximately 15.5 m E and 0.5 m N of SW corner of the interior slab of Hangar 11										
Core No.	Placement Date	Time	Cored Date	Time	Tested Date	Time	Test By	Curing Method	Mass in Air (g)	Mass in H ₂ O	Vol. (cm ³)	Density (kg/m ³)
3279.1			19-Jul-19		22-Jul-19	PM	JLJ	Dry			-	-
3279.2			19-Jul-19		22-Jul-19	PM	JLJ	Dry			-	-
											-	-
											-	-
											-	-
Core No.	Dia. (mm)	Area (cm ²)	Capped Height (mm)	L/D Ratio	Correction Factor (L/D)	Ultimate Load (kN)	Ultimate Stress (MPa)	Corrected Stress (MPa)	Type of Fracture	Test Age	Type of Fracture	
3279.1	100.50	79.33	107.63	1.07	0.887	311.8	39.3	34.9	1		1	Cone
3279.2	100.50	79.33	117.05	1.16	0.908	439.6	55.4	50.3	1		2	Cone and Split
											3	Columnar
											4	Shear Diagonal
											5	Single Edge
											6	End
											ST	Splitting Tensile
Average								42.6				
Remarks:	50 mm stone in samples											
Reviewed By: P.L.(Eng.)												

Data presented hereon is for the sole use of the stipulated client. Tetra Tech is not responsible, nor can be held liable, for use made of this report by any other party, with or without the knowledge of Tetra Tech. The testing services reported herein have been performed to recognized industry standards, unless noted. No other warranty is made. These data do not include or represent any interpretation or opinion of specification compliance or material suitability. Should engineering interpretation be required, Tetra Tech will provide it upon written request.





4.0 PRELIMINARY STRUCTURAL ANALYSIS

A detailed structural analysis of the building is well beyond the scope of this report. The focus for this report was to complete a preliminary Structural Analysis as it relates to Lateral and Roof design loads.

No existing structural drawings were available for review, and as a result, the original structural design loads are not known. The structure are believed to be to have been designed by the American Armed Forces during war times, so it is reasonable that it might have been designed and constructed in accordance with US Army Standards at the time, but that would only be a best guess. As a consequence, it is difficult to compare the design loads changes as the original loads are unknown.

RJC completed the following assessment based on the limited information.

4.1 Lateral Analysis

RJC was asked to provide a preliminary assessment on the ability of the current structure to resist seismic forces. Since the original design code for the building is unknown, a load comparison between the original design lateral loads vs the current designated loads is not possible. In general, though the 1965 National Building Code (NBC) lateral loads are less than the current requirements, so it is reasonable to assume the loads the building's lateral system was designed to originally most likely will be lower than the current code requirements.

Furthermore, there was no clearly visible lateral system in the building when reviewed. The primary structure (large open hanger and post & beam framing in ancillaries with large door openings on north/south wall of hanger) does not lend itself to providing lateral restraint. This likely means the building is at least somewhat dependent on wood walls in the ancillary buildings for its lateral support. Therefore, given the condition of those walls (and plan to remove finishes in short-term to limit damage), there is a reasonable likelihood the lateral restraint may be compromised and rehabilitation will be required regardless of the load differences.

RJC also reviewed the requirements of the current Alberta Building Code 2019 (hereafter referred to as ABC), which now requires seismic design for all buildings. This means the rehabilitation can reasonably anticipate seismic design requirements at a minimum in the repair areas, if not required for the entire structure based on Authority having Jurisdiction (hereafter referred to as AHJ) requirements and amount of repairs needed.

Therefore in short, to upgrade to the current ABC 2019 lateral loads is likely to require significant upgrading and repairs of the existing structure. This will also include detailed measurement and analysis to determine what the capacity of the existing structural elements are. New structural elements, including such members as new steel cross bracing or reinforced wood shear walls, might be needed to reinforce the structure in both the Stabilization and Conservation plans, including potentially some upgrades to foundations.

It is also worth noting that if short-term plan is demolition of finishes to remove organic material, there may be temporary construction of walls to support the building, as it is reasonable to assume the removal of those finishes will decrease the overall lateral stability of the ancillaries.



4.2 Roof Design Load Analysis

RJC was asked to provide a preliminary assessment on the roof design loads. The approach taken was to again investigate the original snow loads against the current code designated snow loads.

Similar to the Seismic analysis, the snow loads since NBC 1965 have increased, the original code employed for the roof design is unknown, and some of the members are damaged beyond repair. RJC anticipates that the ABC 2019 vertical loads for the roof will be greater than those used in the original design. This means upgrading will be required for repaired areas and/or with heavier dead loads (ex. heavier roofing material).

It is anticipated that were this facility to be renovated and re-purposed, the superstructure will most likely need to be upgraded to meet the requirements of the 2019 Alberta Building Code unless otherwise determined by the Authority Having Jurisdiction.

4.3 Summary of Load Impacts

Based on the above, if the Blatchford Field Hangar No. 11 is determined to be salvageable and upgraded to accommodate a proposed redevelopment, extensive material testing and surveying of the existing structural elements will be required. This accumulation of test and survey data will be necessary to allow for detailed structural analysis to determine the current structural capacity. This means that the capacity overall is truly an unknown, which could significantly impact structural repair costs, as the level of upgrade is unknown.

5.0 RECOMMENDATIONS/COSTS

As discussed in the main body of the report, there is a two level rehabilitation scope approach being considered.

1. Stabilization scope: includes stabilization of the structure for the short-term while repairs could be completed to help prevent further deterioration. In this case, the building would remain unoccupied, but repairs would be required to create safe construction areas.
2. Conservation scope: full restoration of the building, including repairs of the building and upgrading to current codes where required by the Authority Having Jurisdiction.

5.1 Stabilization (Short-Term Preservation)

To preserve the structure in short-term, to ensure the building remains stable, the following areas would likely required repair (estimated percentages of area below) based on the portions of the structure that were visible. It is worth noting the below estimated scope are extrapolated from very limited information and include large assumptions.

A short-term stabilization plan is likely to include roughly the following:



- Hanger: expect to complete isolated repairs on approximately 10-20% of the roof deck and joists. Temporary repairs to 5-15% of the ceiling framing, the glulam trusses. Temporary repairs to 25% of the truss columns and braces.
- Western ancillary building: replacement or repair of approximately 50-70% of the floor and roof joists. Upgrading or repair to approximately 15-30% of the post and beams.
- Eastern ancillary building: Replacement or repair of approximately 30-40% of the floor and roof joists. Upgrading or repair to approximately 5-15% of the post and beams.
- Repair or reconstruct approximately 60-75% of the walls on the east/west sides of hanger
- In-depth lateral analysis based on expected remaining walls. I would anticipate construction of 5-10% of the existing walls with standard sheathed shear walls as a temporary measure.
- Repair of roofing (non-structural) and building envelope to limit water infiltration to the structure. Repairs to areas may be required to provide membrane tie-in details and new drain infrastructure, which might require heating to prevent freezing.
- Removal and/or reinforcing of exterior framing that has deteriorated (due to being exposed), to approximately 30-40% of exterior of the building.
- Shoring of certain areas to complete either structural or non-structural repairs. It is tough to estimate quantities required for this at this time.
- With no heat available for building and currently no power, freeze/thaw damage remains an ongoing concern, especially in areas with significant water infiltration. Potential impacts on the foundation/slab due to heaving and drainage issues leading to overloading.

5.2 Conservation (Long-Term Re-Occupied Building)

As noted above, the structure has some significant condition issues. In its current condition the building is not performing as intended for occupancy conditions and repairs would be required if reoccupied. In general extensive structural analysis and site measurements would be required to determine what portions of the structure would need repaired/replaced.

It is worth noting the below estimated scope is extrapolated from very limited information and include significant assumptions. While estimating what is required for full re-occupation is dependent on several factors (i.e. occupancy use, amount of damage found, AHJ's code requirements for upgrading, etc.), a conservation plan would likely include all of the stabilization repairs noted above, plus:

- Based on preliminary use plans, the buildings would need to be split into three buildings, requiring firewalls on east/west walls of the hanger.
 - This would involve dividing the structure and providing new foundation for one side.
 - This would require a double wall be built including modification of existing framing in ancillary areas to bear on new wall and new foundations.
- The firewall would also require additional for new lateral system for the hanger because it is currently believed to be supported by the ancillary buildings.



- For preliminary costing purposes, assume two steel cross brace (or wood shear walls) being added on all four sides of hanger. There may also be foundation adjustments to carry the new lateral loads.
- Repairs to the existing walls in the ancillary buildings will be required to upgrade or restore the lateral system for these buildings. For an approximate costing measure, assume 20% of the interior walls being re-built.
- Repairs to existing structure that has been modified during building use. There are several locations where members have been cut or modified, so repairs would be required to restore these areas. Assume 1 to 3% of the entire structure would require these type of repairs for costing purposes.
- Foundation upgrades to the building to support new loads. This is challenging given generally there is no information available for these foundations. Assume 15 to 40% of the foundation will require modifications.
- If ABC 2019 code upgrades are required laterally or vertically, significant reinforcing of the building might be expected. The amount of repairs cannot be estimated, as it is not known how much will be required.
- Restoration of north and south walls likely would be required including removal of finishes and replacement of framing of small roofs. This is especially true if repairing/restoring overhead doors.

5.3 Considerations For Contemplated Repairs

The following is some important considerations to consider if the building is re-occupied:

- The amount of damage is being extrapolated from very limited information and costs/repairs required could be significantly impacted based on what is found once the finishes are removed.
- The structure is generally a non-standard construction for modern wood buildings. In order to maintain its unique heritage, non-standard construction would be required, which has a cost impact.
- The type of construction may also have an impact use. For example, the spacing of the columns in the ancillary building is quite tight, which may impact layouts for new spaces depending on expected use of the space.
- The building is generally past its projected life cycle and while a large portion may be replaced in the restoration, it will still contain members at the end of their life cycle, which may not have the same life cycle as the plan for the renovated building. This can lead to additional maintenance costs during the project life span or shorter life span of the renovated building.
- Projects that endeavor to repair/upgrade this type of damaged and older wood structure often (in RJC's experience) have equal or higher costs than for a new building with the same square footage. This is exacerbated by the fact the original design code for the building is unknown and that no drawings are available. This will generally increase cost of rehab as it means additional investigations and upgrading are usually required given the amount of unknowns.



- Given the conditions found, a significant number of the finishes would also need to be removed to see the structure. There may be additional structural damage found once the finishes are removed which may impact the heritage finishes intended to remain.

6.0 SUMMARY

Overall, the structure was found to be in very poor to poor condition. Several condition issues were observed during the visual review and it is likely portion of the structure have been compromised beyond repair. In general, the worst areas are the ancillary buildings, especially the western ancillary building and the two dividing walls at either side of the hanger. Furthermore, most areas of the structure have further degraded from the 2017 observed conditions.

Moisture testing was completed throughout the building and significantly high levels were found in all areas. It is expected these conditions are both signs of deterioration and also a key factor in increased rates of deterioration moving forward.

Foundation testing completed resulted in good initial information regarding the type of foundation and slab construction. It appears in the location investigated the foundation concrete appears to be fair condition.

It is important to note that only a visual review was completed along with the small testing program completed. There could be significant damage to the structure that is not visible, which could increase the cost estimates provided significantly. It also means significant extrapolation of the results was completed to estimate the condition of the remaining structure.

A preliminary load analysis of both the lateral and snow loads resulting in the conclusion that the current loads are both likely higher than what the original construction would have been engineered to, although information for the original design loads is unknown.

It is expected given the condition found and the analysis completed, significant analysis and repairs structurally will be required for both the Conservation and Stabilization plans being proposed. Even if Stabilization is considered as a short-term solution, it is likely structural repairs will be required to ensure construction can proceed safely for non-structural work being considered.



We trust that this report meets your needs at this time. Should you need any further assistance on this file or have any questions regarding it, please contact us.

Yours truly,

READ JONES CHRISTOFFERSEN LTD.

Prepared by:



READ JONES CHRISTOFFERSEN LTD.
APEGA PERMIT NUMBER: P152

Michael Fowlie, P.Eng.
Project Engineer

APEGA PERMIT NUMBER: P152

The impending Blatchford neighbourhood redevelopment offers an opportunity to retain remnant aviation heritage on site while creatively introducing uses that are compatible with the future site context.

In order to explore the potential for these future uses, ERA undertook a precedent study for similar adaptive reuse projects, informed in part by the precedents gathered in early 2018 by the Edmonton Heritage Council and Edmonton Historical Board.

From the list of precedents, we distilled five types of uses that seem to emerge from the conversion of sites like this. The uses included Museums & Archives, which we have eliminated from the analysis that follows because this function is already achieved on site at Hangar 14.

The other four uses include:

- Community Hubs: Public & Revenue-Generating Uses
- Commercial: Retail, Food Service
- Corporate / Institutional Campus
- Athletic / Recreation / Community Centre

We proceeded to develop a hypothetical ‘model’ scenario for each use type, each informed by relevant precedents that were studied. *The hypothetical scenarios presented are not plans or proposals for redevelopment; they are simply explorations of what a conversion for those uses might involve.* They are intended to spark imagination, and should not be taken as comprehensive strategies or proposals for the building and site.

Each hypothetical scenario is followed by a breakdown of the precedent adaptive reuse projects that informed the hypothetical scenario’s development.



**COMMUNITY HUB: PUBLIC &
REVENUE-GENERATING USES**

COMMUNITY HUB: PUBLIC & REVENUE-GENERATING USES

Hypothetical Scenario

HYPOTHETICAL ADAPTIVE REUSE SCENARIO:

- Building stabilization. Central hall prepped for safe occupancy.
- City retains tenure. Establishes a program of markets, festivals, events and other programs on weekends, in partnership with key local stakeholders.
- Stakeholder group seeks philanthropic funding and, if desired, non-profit operators, e.g. arts organizations.
- Donations fund the phased restoration of east wing (offices), west wing (maker spaces), two east auxiliary retail units, skate park/skating rink, and heritage restoration/interpretive program.
- City retains tenure, but site is programmed via a non-profit operator. Offices, maker spaces, retail units generate a revenue stream.

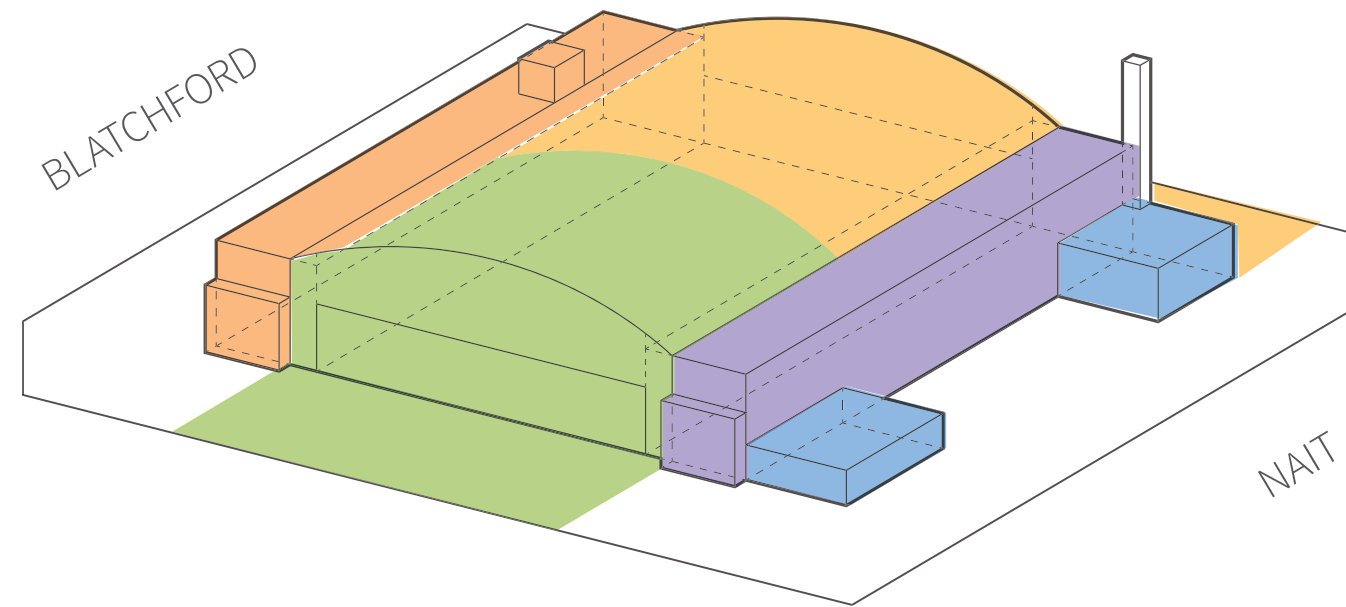

COMPONENTS:

- office space: social enterprises / hot desks
- community-oriented retail: cafe, bike shop
- flex space: farmer's markets / craft markets / winter festivals
- workshops / maker spaces
- lightly designed rec zone: skate park in summer, skating rink in winter



EVERGREEN BRICK WORKS, TORONTO



EVERGREEN BRICK WORKS, TORONTO

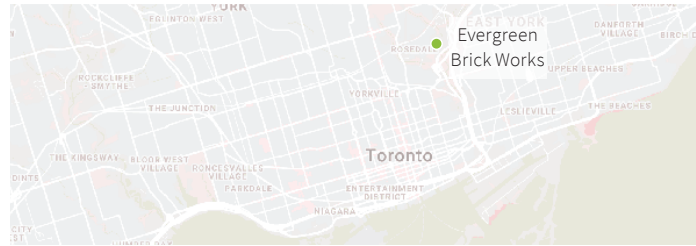
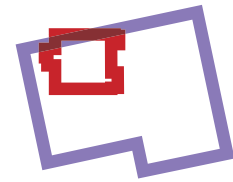

Historical



Don Valley Brick Works, 1952 (James Victor Salmon, Toronto Public Library)

Present Day



Evergreen Brick Works (Claude Cormier et associés)

Key Facts

- Location: Don River Valley, Toronto
- Size: 4 acres of buildings
- Historical use: Don Valley Brick Works Ltd. (1889 - 1991)
- Owner: The Toronto & Region Conservation Authority (TRCA)
- Initiator: Evergreen (urban environmental non-profit org.)
- Present use: Community environmental hub



Aerial view (Claude Cormier et associés)



Winter skating rink, partial open air (Fly Porter)



Chimney Court Children's Garden (Yelp)



Cafe Belong, right, and open plaza beyond (Morgan Yew)

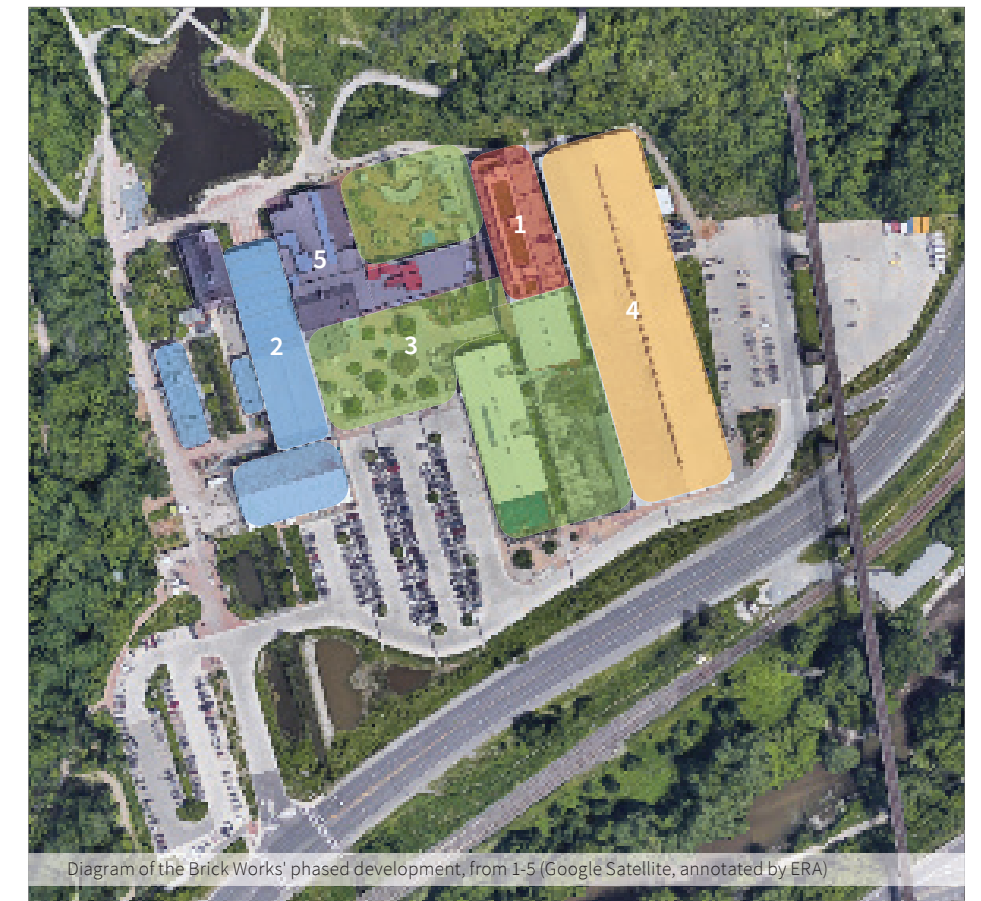

Diagram of the Brick Works' phased development, from 1-5 (Google Satellite, annotated by ERA)



**COMMERCIAL:
RETAIL, FOOD SERVICE**

COMMERCIAL: RETAIL, FOOD SERVICE

Hypothetical Scenario

HYPOTHETICAL ADAPTIVE REUSE SCENARIO:

- Building stabilization.
- North section is prepped for light industrial/commercial occupancy. City retains tenure.
- A brewery (or roastery) moves in, production + retail location. Draws public interest through retail service, indoor-outdoor patio, rentable event space.
- City eventually uses rental revenue to convert the south section as a food hall, + building restoration and interpretive program.
- City retains tenure and collects revenue from tenants.

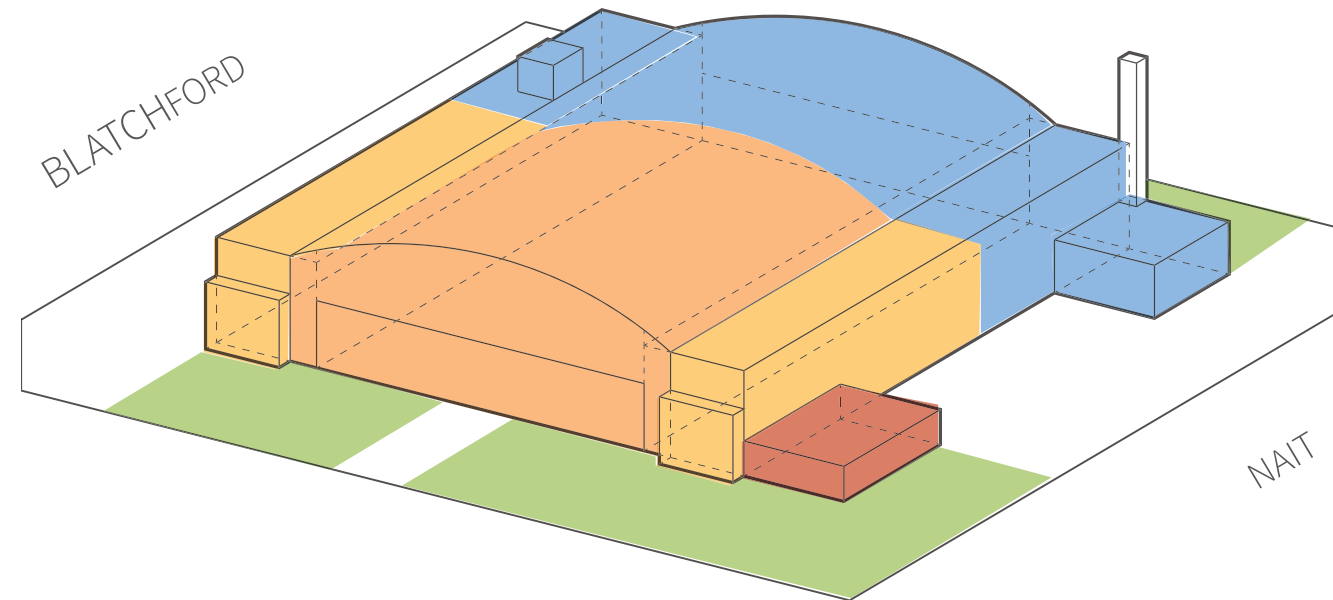

COMPONENTS:

- food hall: tables, central food retail bars
- food retailers: food prep, service counters
- small restaurant with private seating
- brewery: equipment, offices, seating
- patios: retail (south), brewery (north)



THE FORKS MARKET, WINNIPEG



THE SIMMONS BUILDING, CALGARY



HUNTER-GATHERER BREWERY AT CURTISS-WRIGHT HANGAR, COLUMBIA SC



THE FORKS MARKET, WINNIPEG

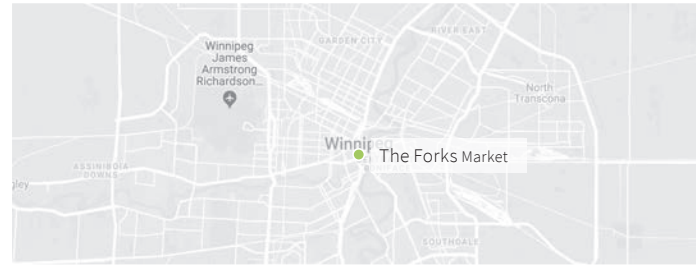
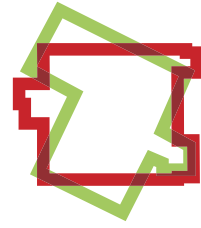

Grand Trunk Pacific and Great Northern Railway Stables, bottom left, 1970 (Winnipeg Tribune)



The Forks Market, left (The Forks)

Key Facts

- Location: The Forks, Winnipeg
- Size: 1.2 acres
- Historical use: G. T. Pacific & Great Northern Railway stables (1910...)
- Owner: North Portage Development Corp. (tri-level agency)
- Initiator: Forks Renewal Corporation (now the NPD Corp.)
- Present use: Food and retail market



The Forks Market (The Forks.com)



Interior (Number10)



Contemporary bar (Number10)

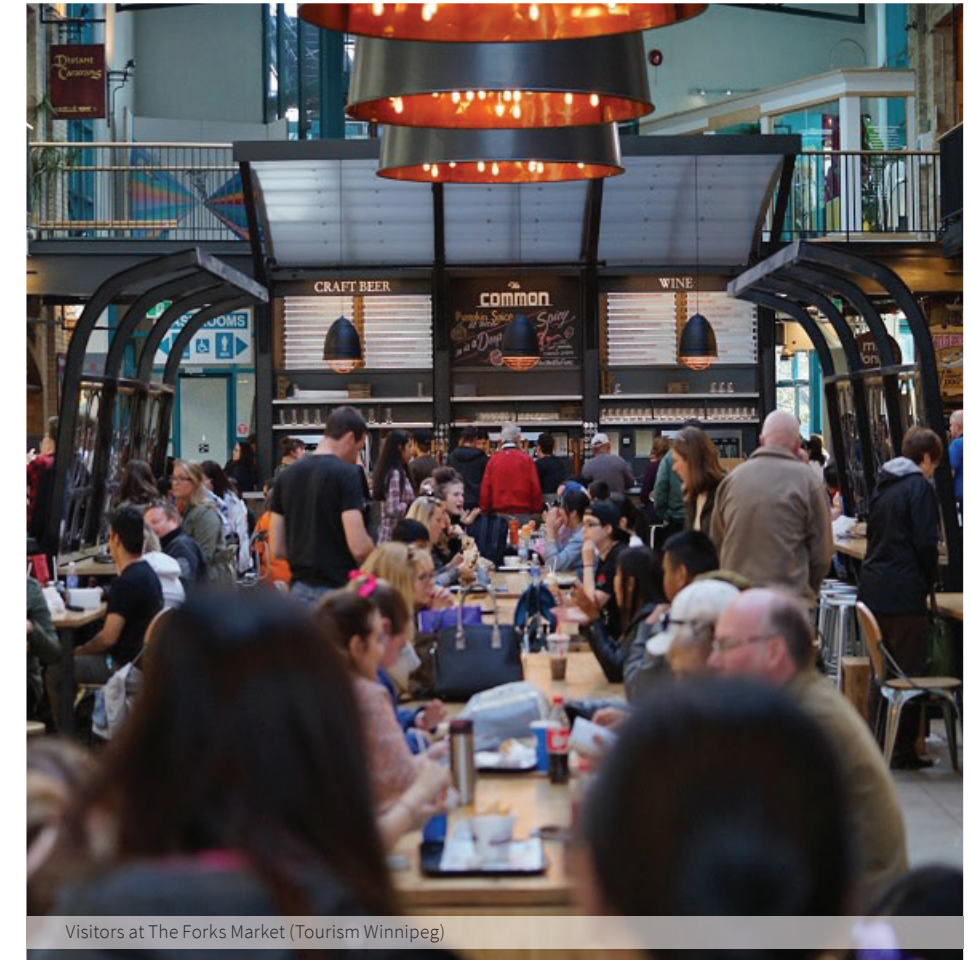

Visitors at The Forks Market (Tourism Winnipeg)



Contemporary bar (Number10)

HUNTER-GATHERER BREWERY & TAPROOM, COLUMBIA, SC

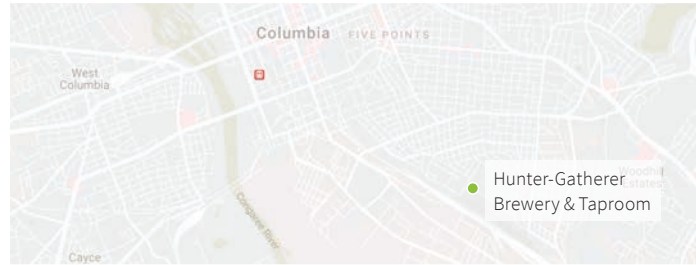

Historical



Curtiss-Wright Hangar at Owens Field, 1940 (Fly K Cub)

Present Day



Hunter-Gatherer Brewery Hangar (Hunter-Gatherer Brewery)

Key Facts

- Location: Columbia, South Carolina
- Size: .3 acres
- Historical use: Curtiss-Wright Hangar (1929-1962)
- Owner: Scott Linaberry and partners
- Initiator: Scott Linaberry and Kevin Varner
- Present use: Hunter-Gatherer Brewery & Taproom

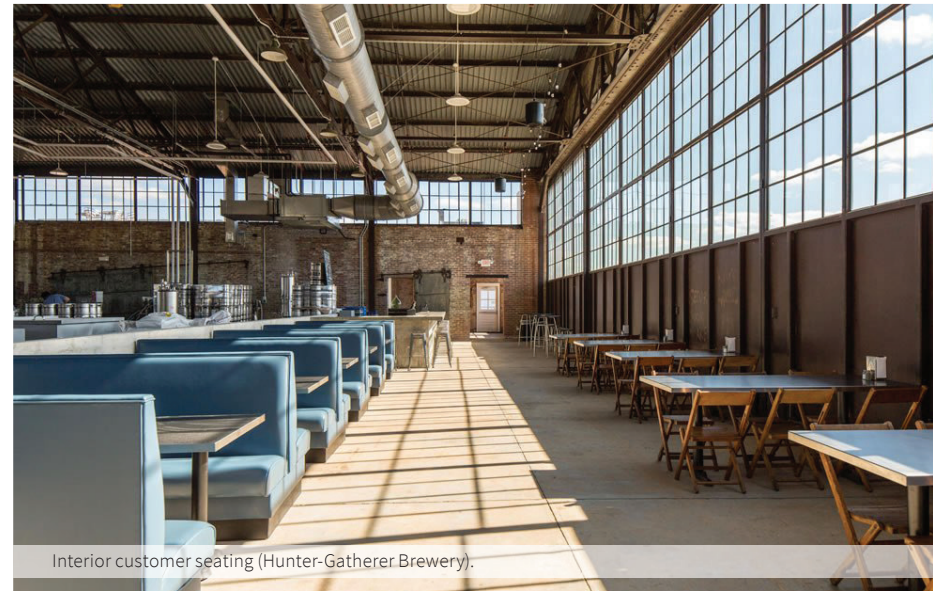

Interior customer seating (Hunter-Gatherer Brewery).

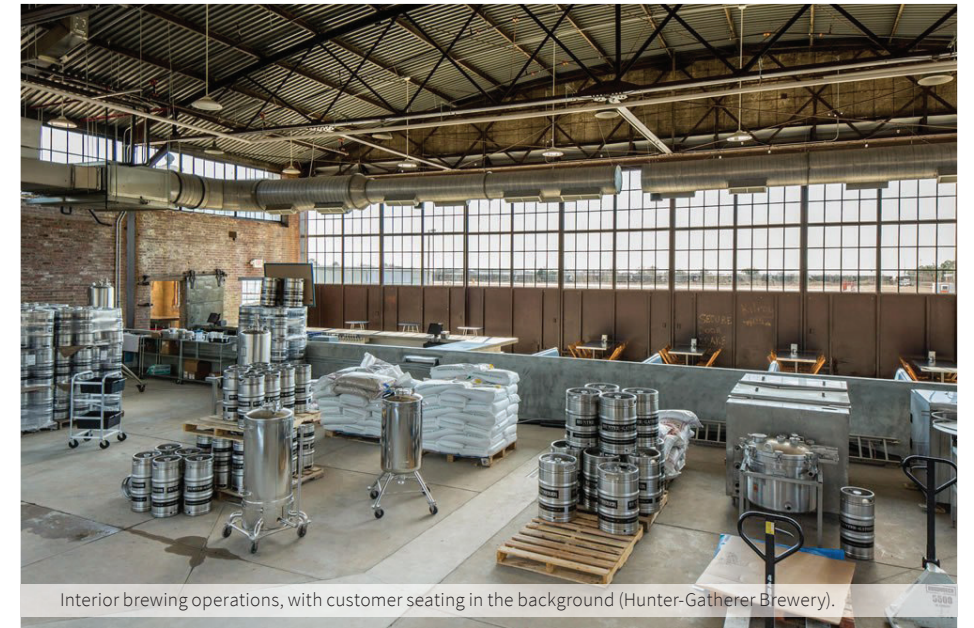

Interior brewing operations, with customer seating in the background (Hunter-Gatherer Brewery).

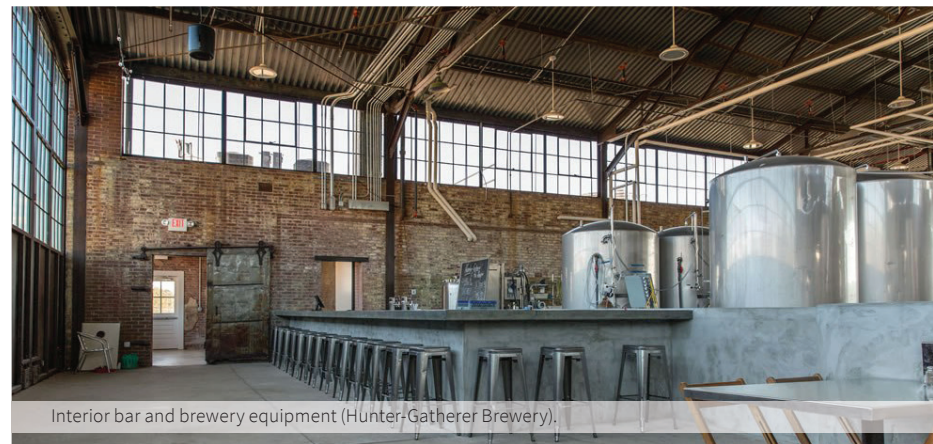

Interior bar and brewery equipment (Hunter-Gatherer Brewery).



Interior (Buchanan Construction Services).



Exterior view (Foursquare).

SIMMONS BUILDING, CALGARY

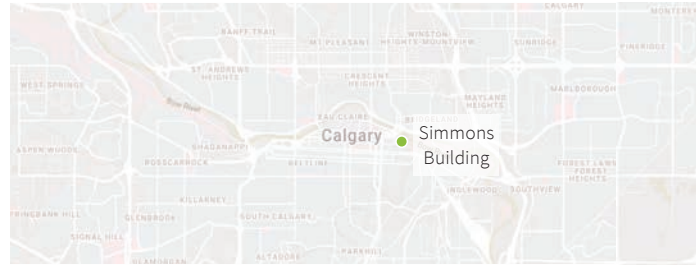
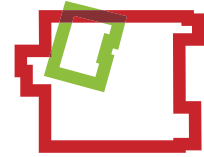

Historical



Alaska Western Bedding Co., 1912 (Glenbow Archives)

Present Day

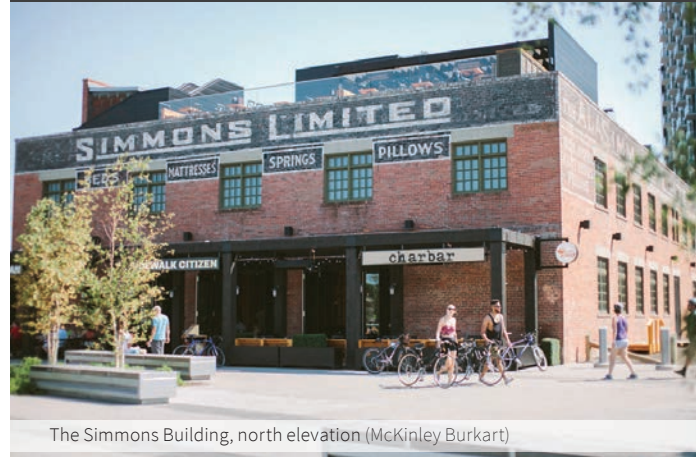

The Simmons Building, north elevation (McKinley Burkart)

Key Facts

- Location: East Village, Calgary
- Size: .22 acres
- Historical use: Alaska Bedding / Simmons Factory Warehouse (1912-1966)
- Owner: The Calgary Municipal Land Corporation (City of Calgary)
- Initiator: The Calgary Municipal Land Corporation
- Present use: Restaurant / Bakery / Cafe & Cafe Head Office/Roastery



Phil & Sebastian Cafe (Phil & Sebastian)

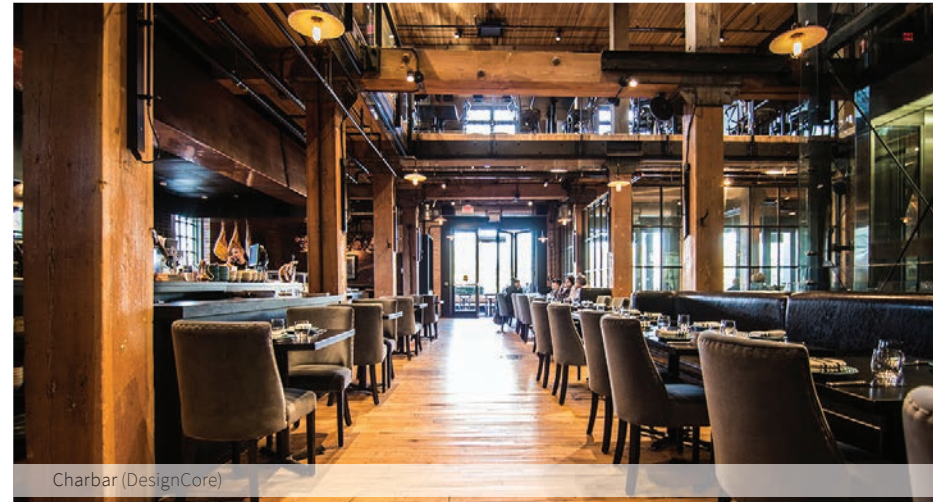

Charbar (DesignCore)



Phil & Sebastian Cafe, left, and Charbar, right (Reinbold Engineering)



Simmons Building in winter, east elevation (ERA Architects, 2018)

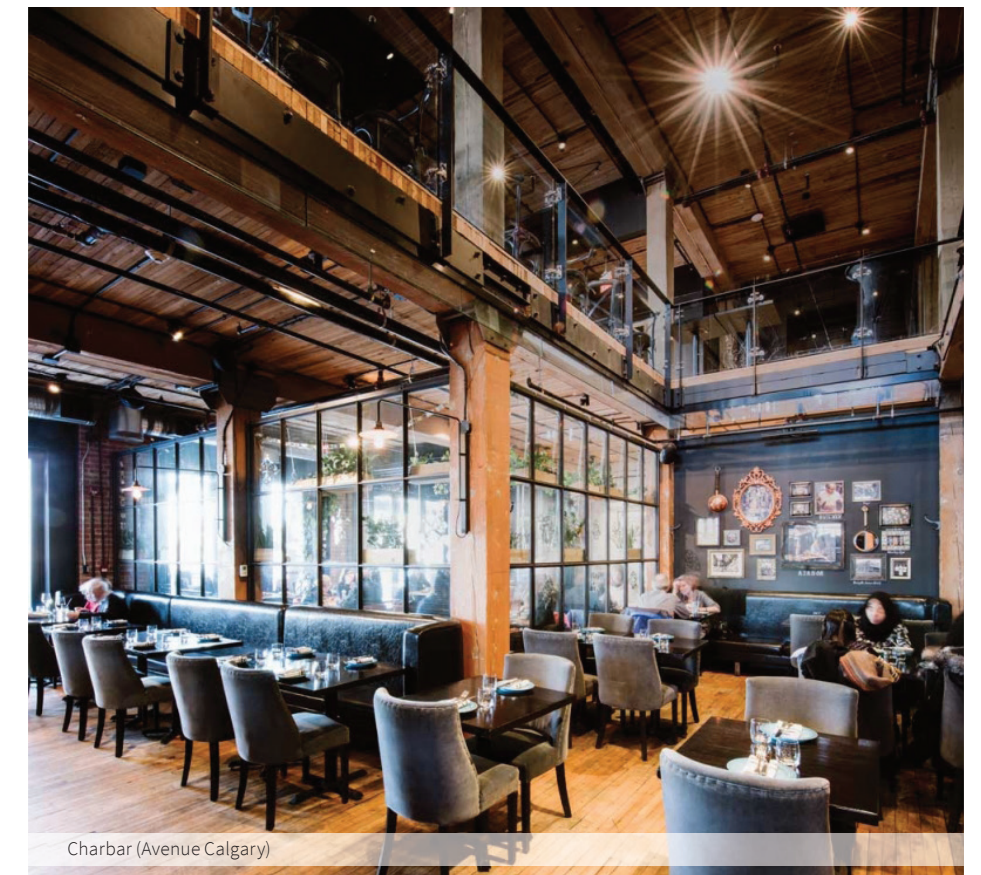

Charbar (Avenue Calgary)



**CORPORATE /
INSTITUTIONAL CAMPUS**

CORPORATE / INSTITUTIONAL CAMPUS

Hypothetical Scenario

HYPOTHETICAL ADAPTIVE REUSE SCENARIO:

- Site is sold to a major institution.
- The institution determines its programmatic requirements: e.g. a gap in its current campus facilities, or a program that requires a new building.
- A comprehensive redesign occurs. Includes building stabilization and restoration, contemporary interior build out, public realm integration, heritage interpretation program.
- Atrium is available as event space for the institution, and for external rentals.

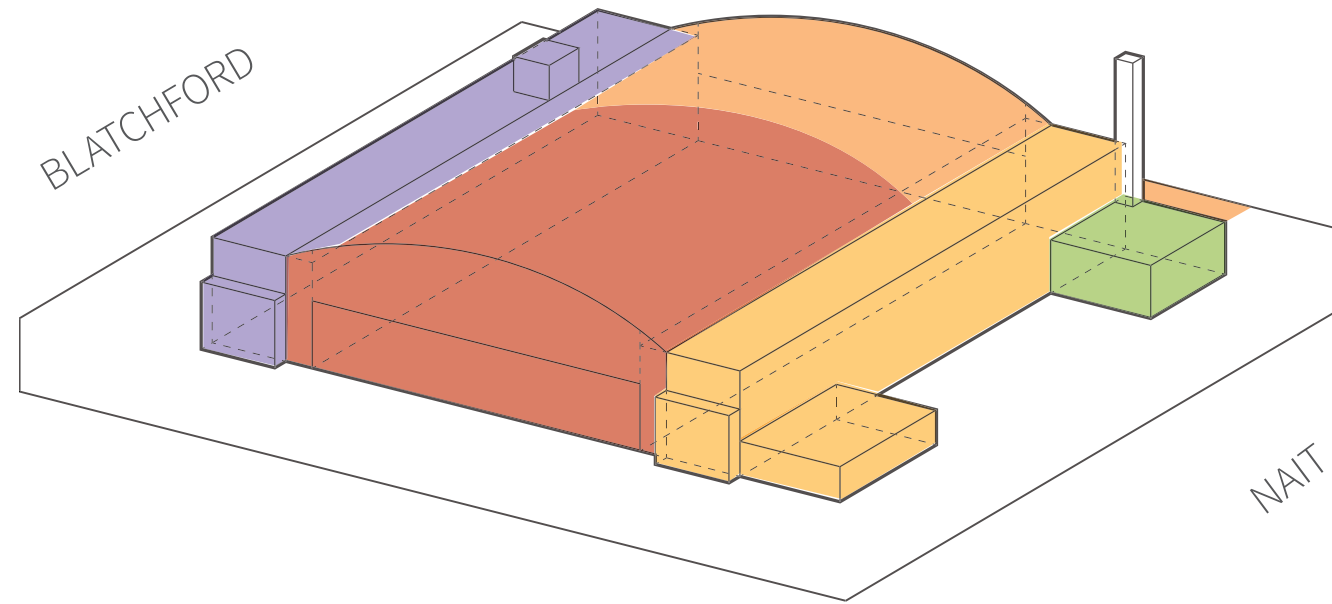

COMPONENTS:

- atrium/event space
- administrative offices
- service wing
- campus bookstore
- contemporary build out: lecture halls, demonstration workshops, study lounges, breakout rooms, labs



GOOGLE SPRUCE GOOSE CAMPUS, LOS ANGELES CA



UNIVERSITY OF WINDSOR SCHOOL OF CREATIVE ARTS, WINDSOR ON

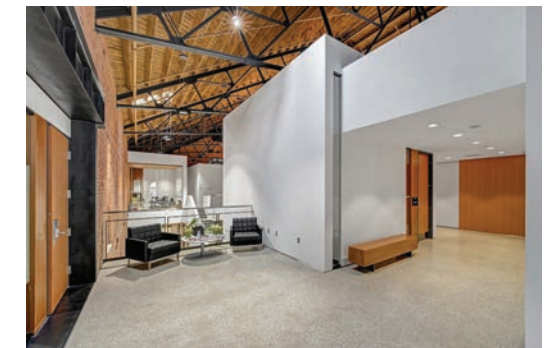
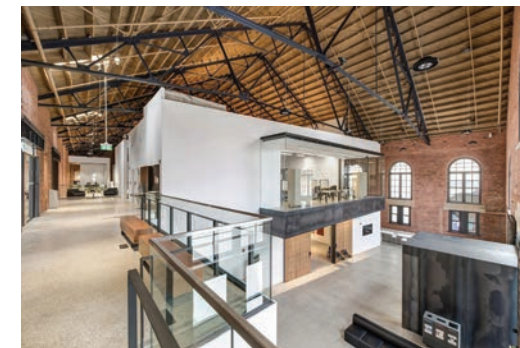

UNIVERSITY OF WINDSOR SCHOOL OF CREATIVE ARTS

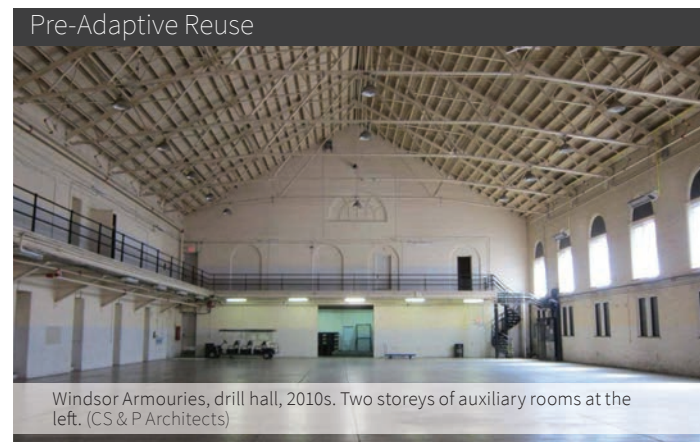
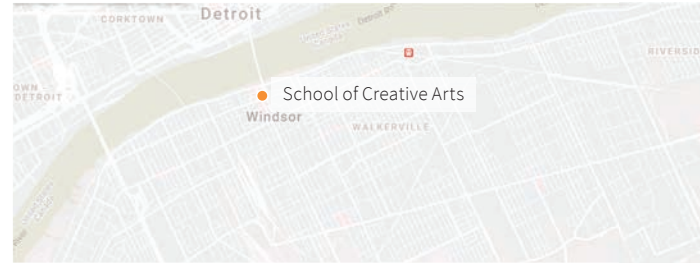
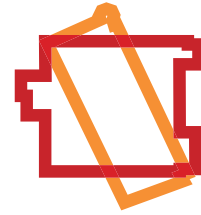

Key Facts

Location: Windsor, Ontario
 Size: .5 acres
 Historical use: Windsor Armouries (1902-2004)
 Owner: University of Windsor
 Initiator: University of Windsor
 Present use: University of Windsor School of Creative Arts

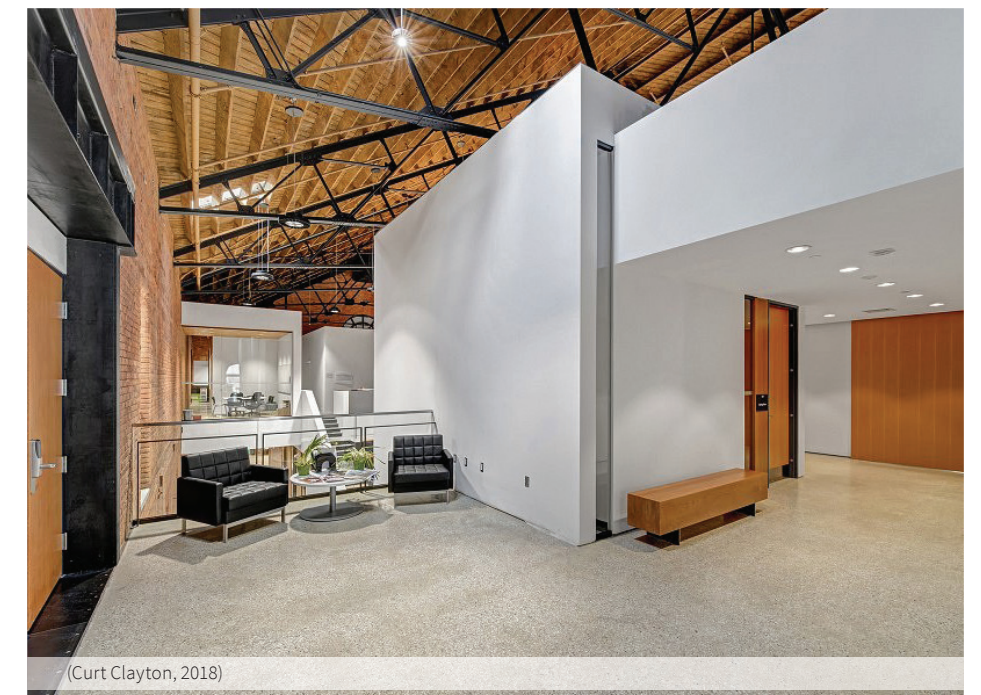
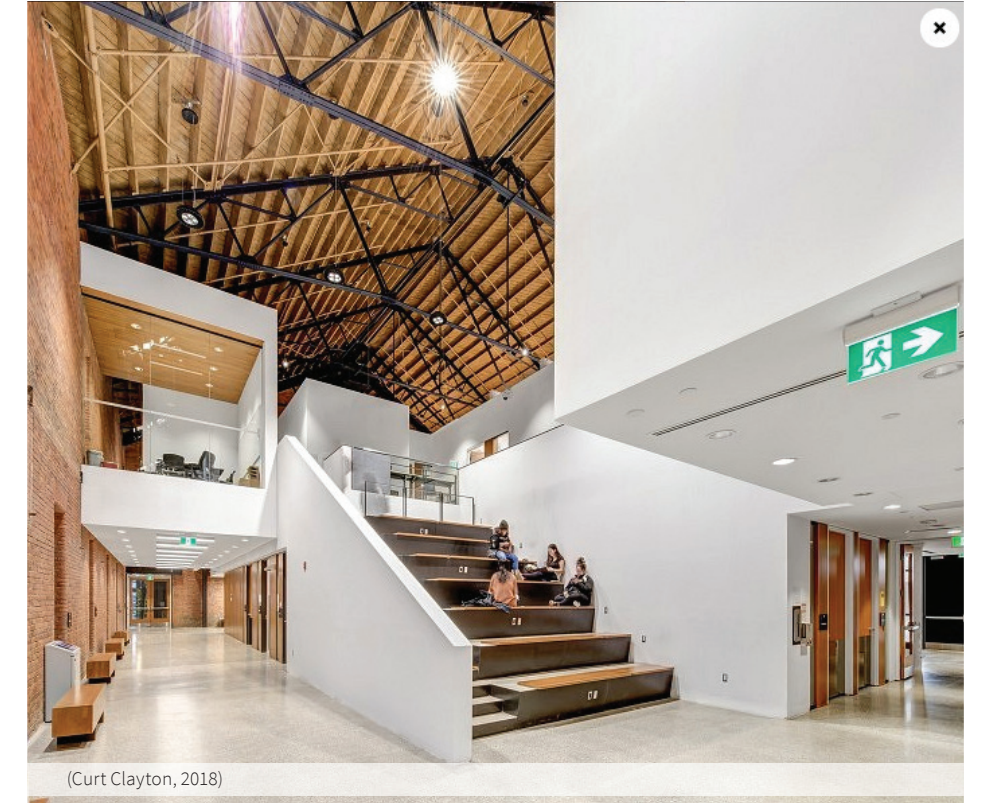
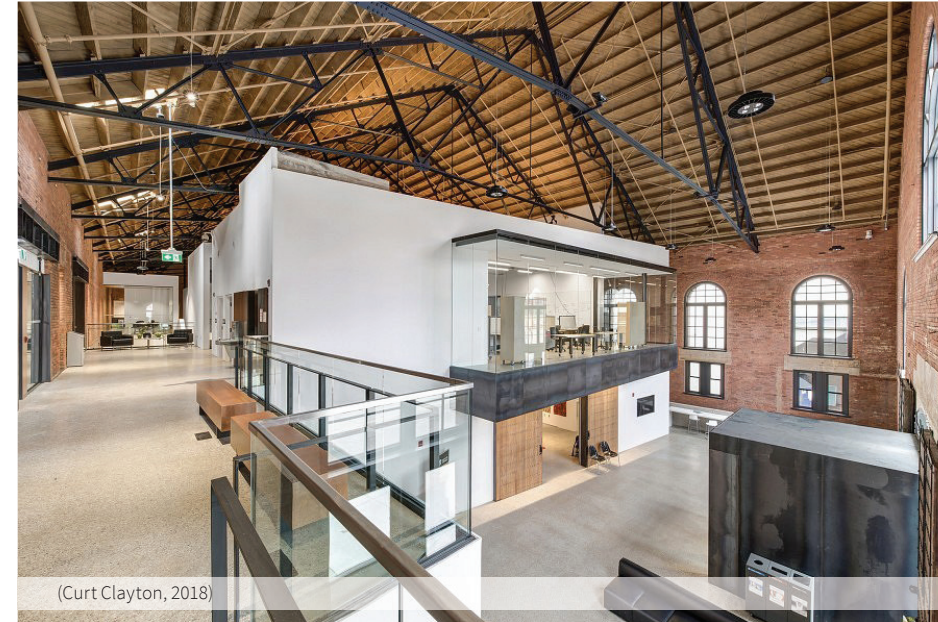

GOOGLE SPRUCE
GOOSE HANGAR

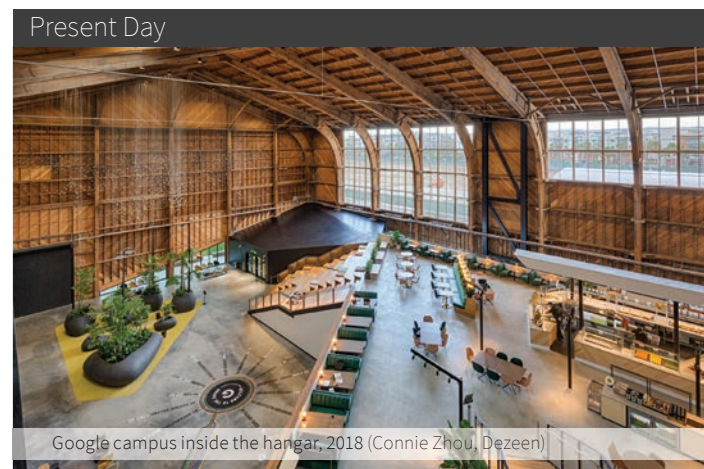
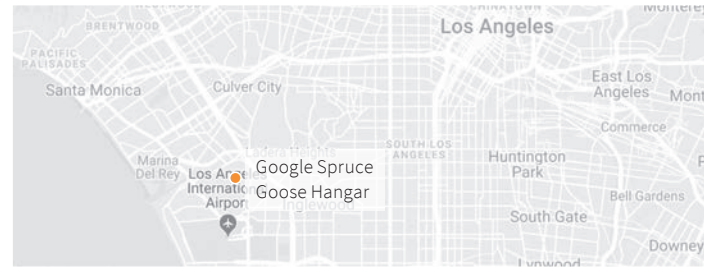
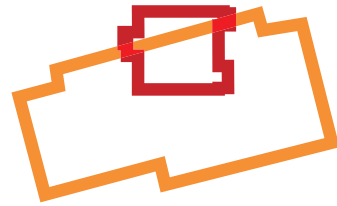

Key Facts

- Location: Playa Vista, Los Angeles
- Size: 5.6 acres
- Historical use: Howard Hughes hangar for the H-4 Hercules (1943-1970s)
- Owner: ASO Group (investment firm)
- Initiator: Google
- Present use: Google campus

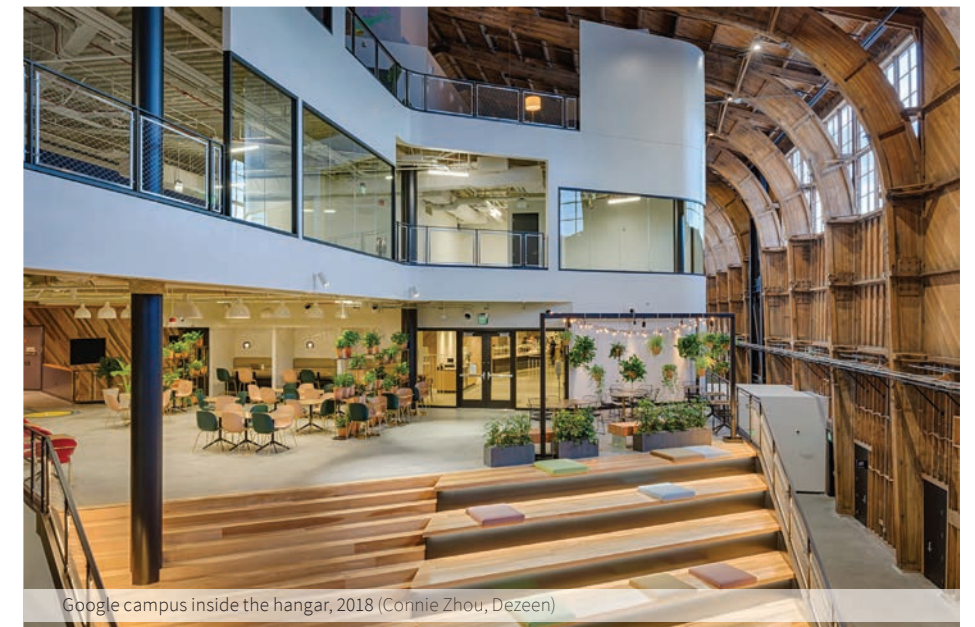
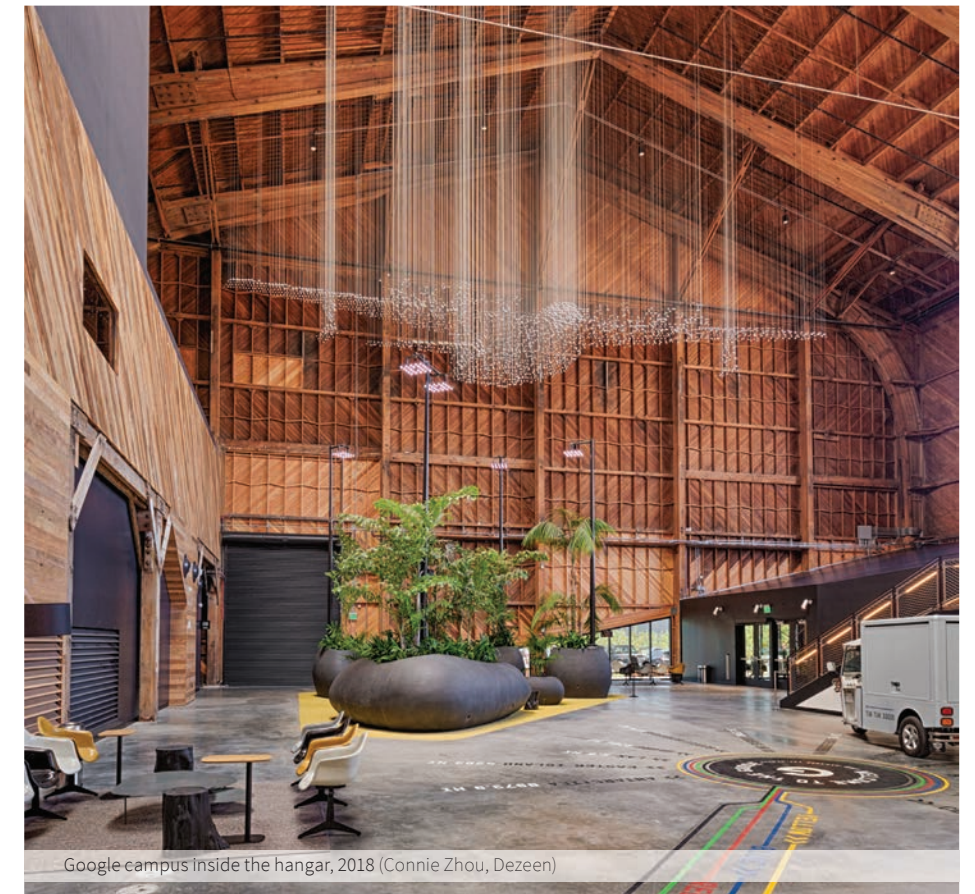
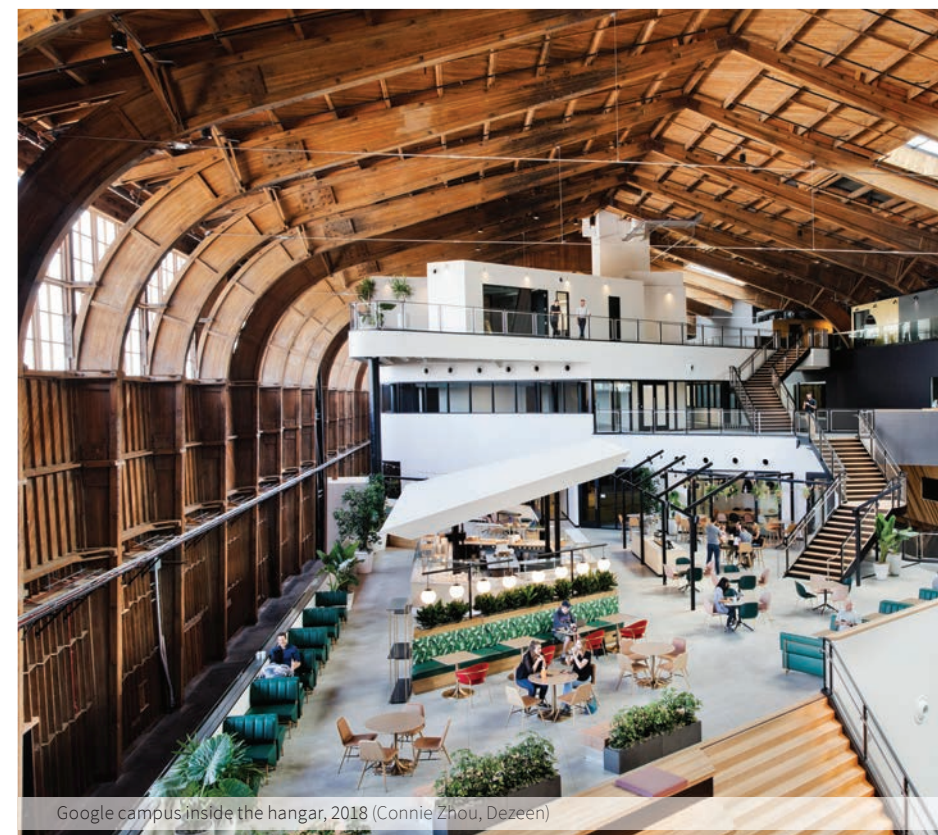
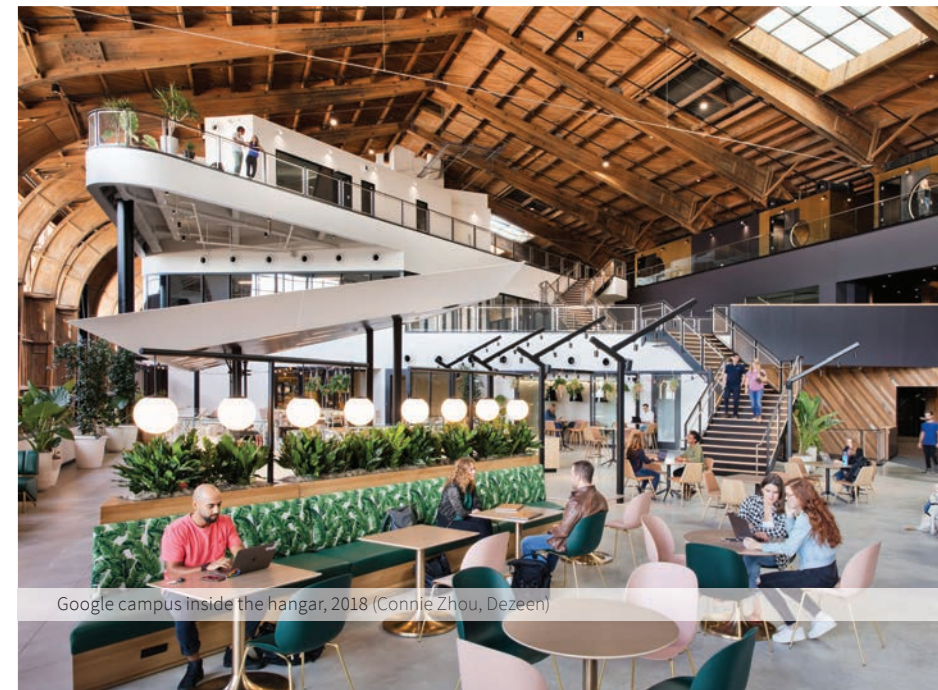



**ATHLETIC / RECREATION /
COMMUNITY CENTRE**

ATHLETIC / RECREATION / COMMUNITY CENTRE

Hypothetical Scenario

HYPOTHETICAL ADAPTIVE REUSE SCENARIO:

- Hangar 11 is established as the community recreation centre for the Blatchford neighbourhood.
- City has option to establish partnership(s) with post-secondary institution(s) for funding and use of athletic facilities, e.g. new indoor soccer field.
- Central hall is adapted to incorporate a soccer field and ball hockey rink. East wing adapted for offices, storage rooms, smaller program spaces, snack bar.
- At a later phase, west wing adapted for squash courts, fitness centre. Removable floor cover facilitates central hall's conversion for events.
- At a later phase, building restoration and interpretive program.

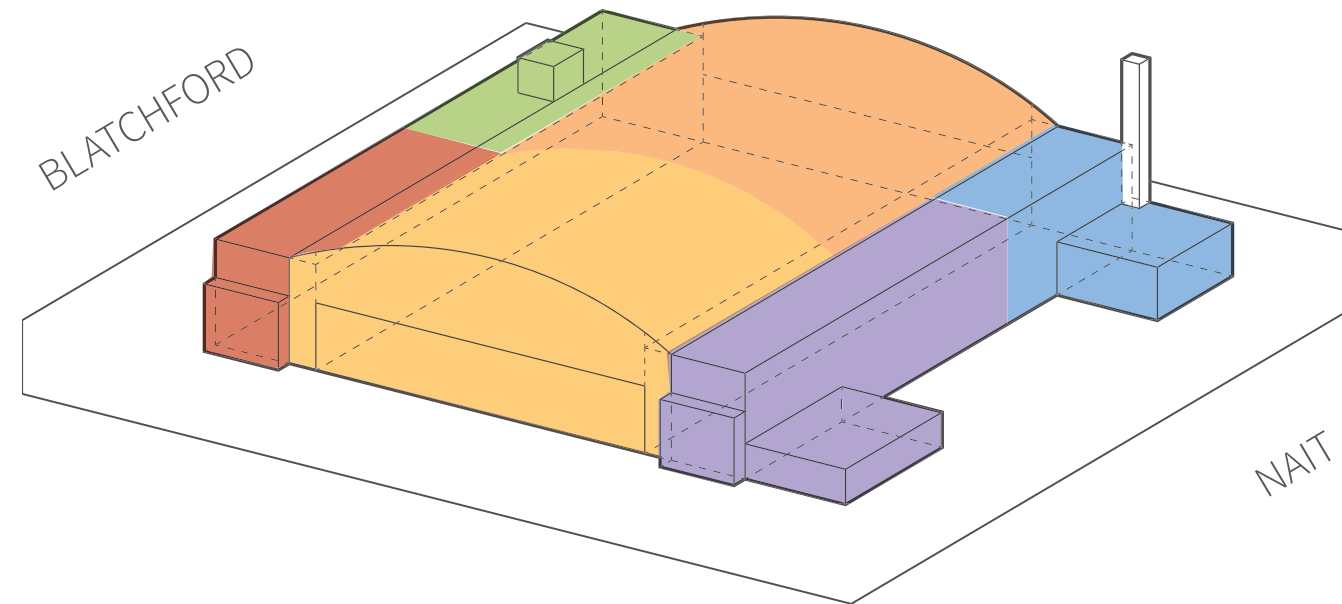

COMPONENTS:

- soccer field
- ball hockey rink
- community centre offices / program rooms
- squash courts
- fitness centre
- snack bar



HANGAR 38, STATEN ISLAND NY (PROPOSED)

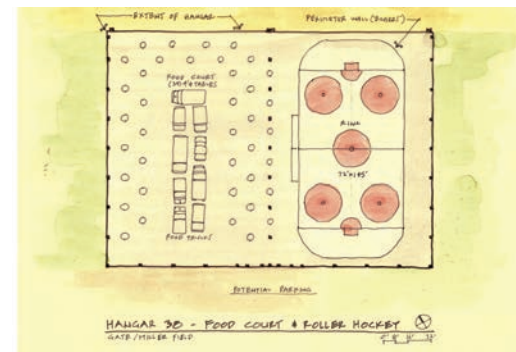

THE HANGAR, DOWNSVIEW PARK, TORONTO



HANGAR 38, MILLER FIELD, STATEN ISLAND

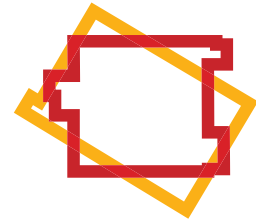

Key Facts

- Location: Gateway National Recreation Area, Staten Island
- Size: 1.5 acres
- Historical use: US Army Hangar (1920-1969)
- Owner: National Park Service
- Initiator: National Park Service
- Present use: None

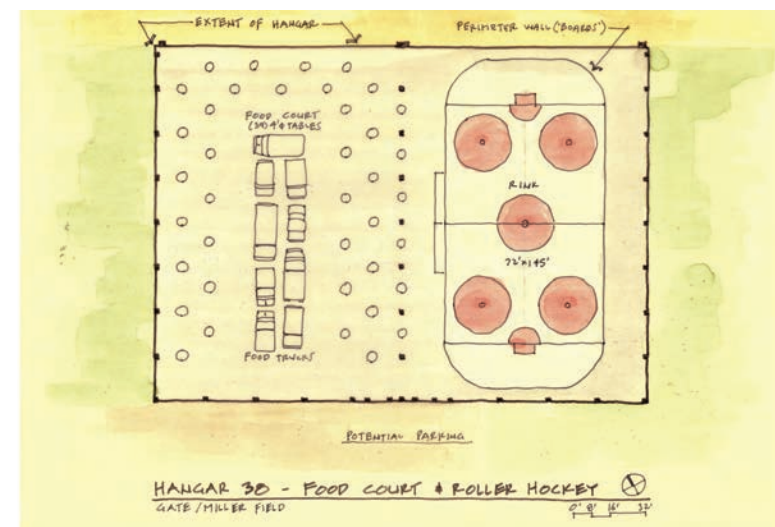

Far Left: A sketch from a National Park Service RFP briefly released in 2016, imagining a potential recreation space at Hangar 38.

Left: Hangar 38 and Miller Field seen from above (Google Satellite)

THE HANGAR, DOWNSVIEW PARK, TORONTO

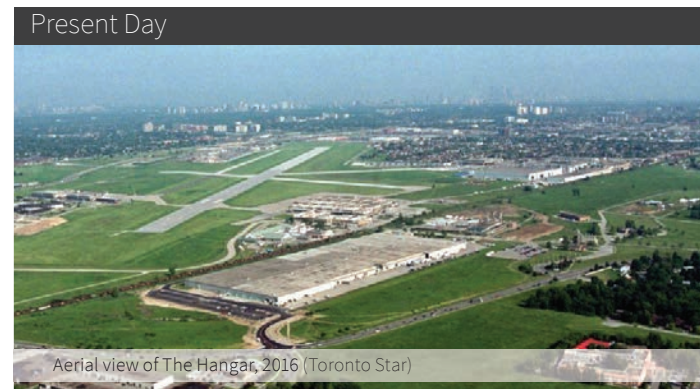
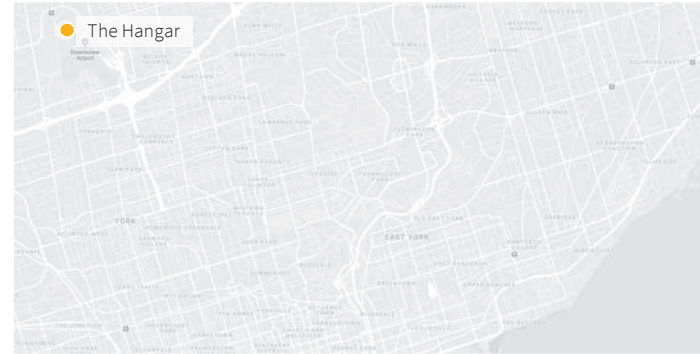
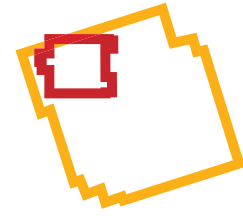

Key Facts

Location: Downsview Park, Toronto
 Size: 8.7 acres
 Historical use: RCAF Station Downsview / DeHavilland plant (1929-1996)
 Owner: Canada Lands Company (Government of Canada)
 Initiator: Francois Glasman & Bert Lobo
 Present use: The Hangar Sports Centre (4 fields, ball hockey rink, Hoop Dome, Grand Prix Kartways, climbing facility).

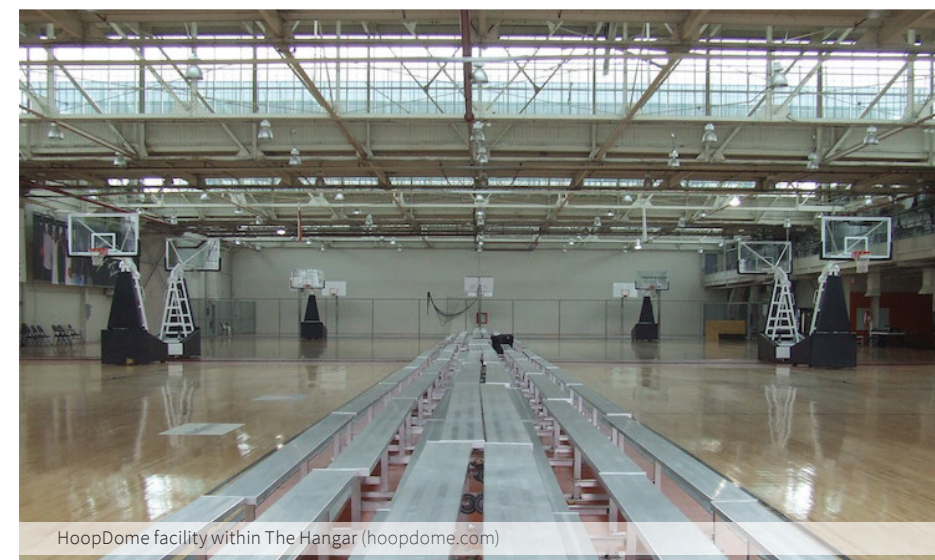



13.1 Indigenous History (Pre-Contact to Present)

Hangar 11 is located on the traditional territory of the Woodland Cree, Plains Cree, Metis and Tsuu T'ina peoples. These indigenous groups are comprised of a number of distinct communities that have been present on the Site and surrounding lands in and around the North Saskatchewan River Valley for thousands of years.

The area has served as a gathering place for diverse Indigenous peoples including the Cree, Nizitapi (Blackfoot), Metis, Nakota Sioux, Haudenosaunee, Dene, Ojibwe / Saukteaux / Anishinaabe, Inuit and many others.

Archaeological evidence has shown that in the early 1700s, Nizitapi communities likely occupied the North Saskatchewan River Valley in the area that is now Edmonton. Written and reported records by early European fur traders notes that Cree and Assiniboine groups were also present in the area. At the time of initial contact and the years that followed in the mid-to-late 1700s, the area was recognized as being in a transition zone between Nizitapi and Cree territories, between Plains cultural communities to the south, and Woodland cultural communities to the north.

Following the establishment of fur-trade outposts by the Hudson's Bay and North West Companies in the 1790s, tensions escalated between the Nizitapi, and the Cree and Assiniboine, the latter of whom had been generally working with and benefitting from their relationships with the fur-trade companies for some decades across the Plains. The shift westward of the rival fur-trade companies also forecasted the arrival of a significant Metis community in the Edmonton area; Metis communities generally settled in the vicinity of company outposts and forts in the west given their economic and cultural ties to the fur trade.

Over the 19th century, the growing Plains buffalo hide trade forecasted the decline of the buffalo population, which boded poorly for the Plains bands of Nizitapi, Assiniboine and Cree, as well as many Metis communities in the region. Following the Hudson's Bay Company's sale of Rupert's Land to the Canadian government in 1869, the local indigenous communities sought a treaty with the Canadian government to secure their rights to land against impending white settlement.

PREVIOUS PAGE: Driscoll & Knight's 1907 map of the city of Edmonton and environs. The future location of Hangar 11 is indicated with a red arrow (Peel's Prairie Provinces, annotated by ERA).

Treaty 6 (1876)

Today, the Hangar 11 property falls within Treaty 6 lands, which stretch throughout central Saskatchewan and Alberta. Treaty 6 was signed in August-September 1876 by both representatives of the Crown and Cree, Assiniboine, and Ojibway leaders.

The Treaty was sparked by the Canadian government's recognition that westward expansion and settlement would be simplified through the development of an agreement. Negotiations were conducted through 1876, and the treaty was ultimately signed without an explicit explanation of the concept of land cession by Crown representatives.

As per Treaty 6, the indigenous signatories agreed to relinquish the title to their lands in exchange for:

- An annual cash payment of \$25 per chief, \$15 per headman, and \$5 per every other band member;
- A one-time cash payment of \$12 to all band members;
- Reserve lands of 1 mile squared per family of five, which would include schools;
- Twine and ammunition valued at \$1,500 per year;
- Agricultural implements such as gardening tools, livestock, horses and wagons;
- \$1,000 in agricultural provisions per year, for three years, for indigenous peoples farming on reserves;
- A medicine chest, stored at the home of the local Indian Agent; and,
- Retention of hunting, trapping and fishing rights on reserve lands.

A number of reserves were established within Edmonton's vicinity following the signing of Treaty 6, and the local indigenous peoples were relocated to reserve lands and directed to undertake agricultural economic practices. Many of their children were sent to the assimilationist residential schools established in proximity to their reserves at St. Albert.

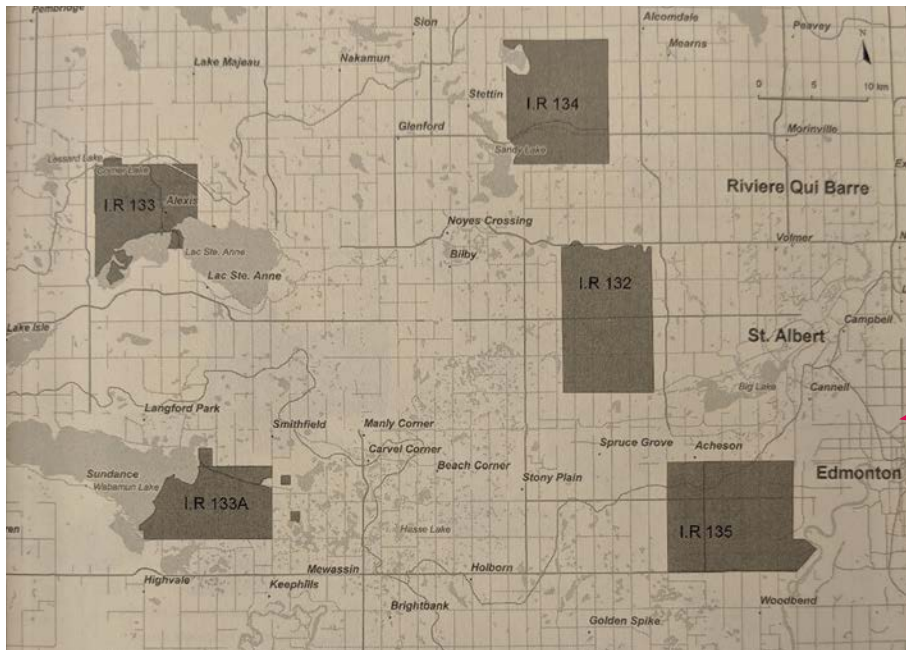

Reserves within the Edmonton agency of Treaty 6: The Michel Callihoo Reserve (I.R. 132), the Alexis Reserve (I.R. 133), the White Whale Lake or Paul Reserve (I.R. 133A), the Alexander Reserve (I.R. 134) and the Enoch or Stony Plain Reserve (I.R. 135). The approximate site of Hangar 11 is indicated with a red arrow. (D. J. Hall's *From Treaties to Reserves: The Federal Government and Native Peoples in Territorial Alberta, 1870-1905*, annotated by ERA).

Indigenous Presence in Edmonton Today

Today, Edmonton has one of the Canada's largest urban indigenous populations, second only to Winnipeg. The Confederacy of Treaty Six First Nations, created in 1993, incorporates the various band governments of Treaty 6, and is active in the protection of treaty rights and economic, political, and cultural support for the communities it represents.

13.2 Early Settlement History

Hangar 11 is located at the north end of what was originally Edmonton's 3,000-acre Hudson's Bay Company Reserve, once land ownership and property rights had been established in the area.

Fur traders from both the Hudson's Bay and North West Companies arrived in the Edmonton area in the mid-1700s, with both companies formally establishing a settler presence there in the 1790s. In 1795, both companies built trade forts on the North Saskatchewan River.

The two companies merged in 1821 under the name Hudson's Bay Company. Company employees lived at Fort Edmonton, but the company soon became the basis for settlement expansion on the banks of North Saskatchewan River, driven in part by the arrival of missionaries, and other non-fur-trade employees like miners en route north to gold fields.

In 1869, when the Hudson's Bay Company sold Rupert's Land to the Canadian government as the Northwest Territories, government surveyors divided the land into sections and quarter sections.

Several categories of land were exempt from the survey: lands reserved for the Canadian Pacific Railway, which was viewed by the federal government as a nation-building necessity, lands allocated for indigenous band reserves, and lands allotted to the Hudson's Bay Company. As part of the Rupert's Land sale, the Hudson's Bay Company was allowed to retain 3,000 acres in blocks around their existing forts across the territory. In Edmonton, the Hudson's Bay Company conducted an 1881 subdivision survey of its 3,000 acres of reserve lands.



Above: A 1929 depiction of the subdivided 3,000-acre Hudson's Bay Reserve, with yellow lots showing those lots sold as of May 1929. (Peel's Prairie Provinces).

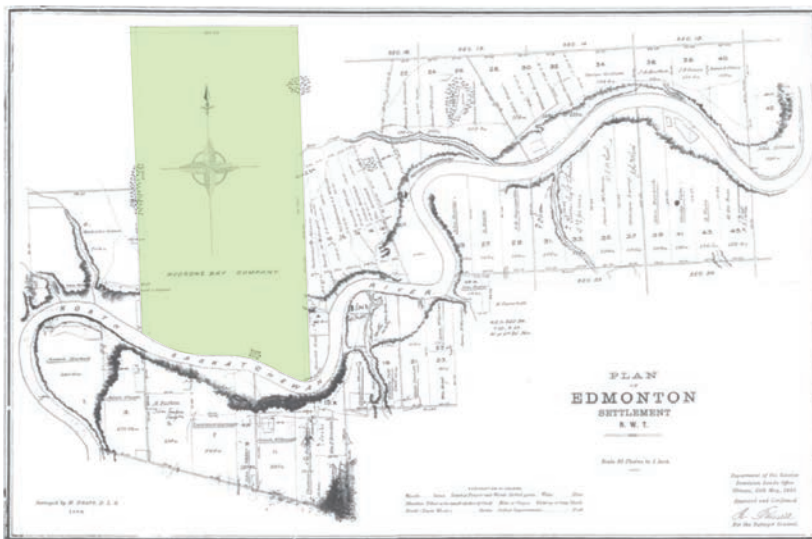

Left: An 1883 Sketch of the Edmonton Settlement by Michael Deane, surveyor. The 3,000 acres of Hudson's Bay Company reserve lands are highlighted in green, north of the River. (City of Edmonton Archives, annotated by ERA).

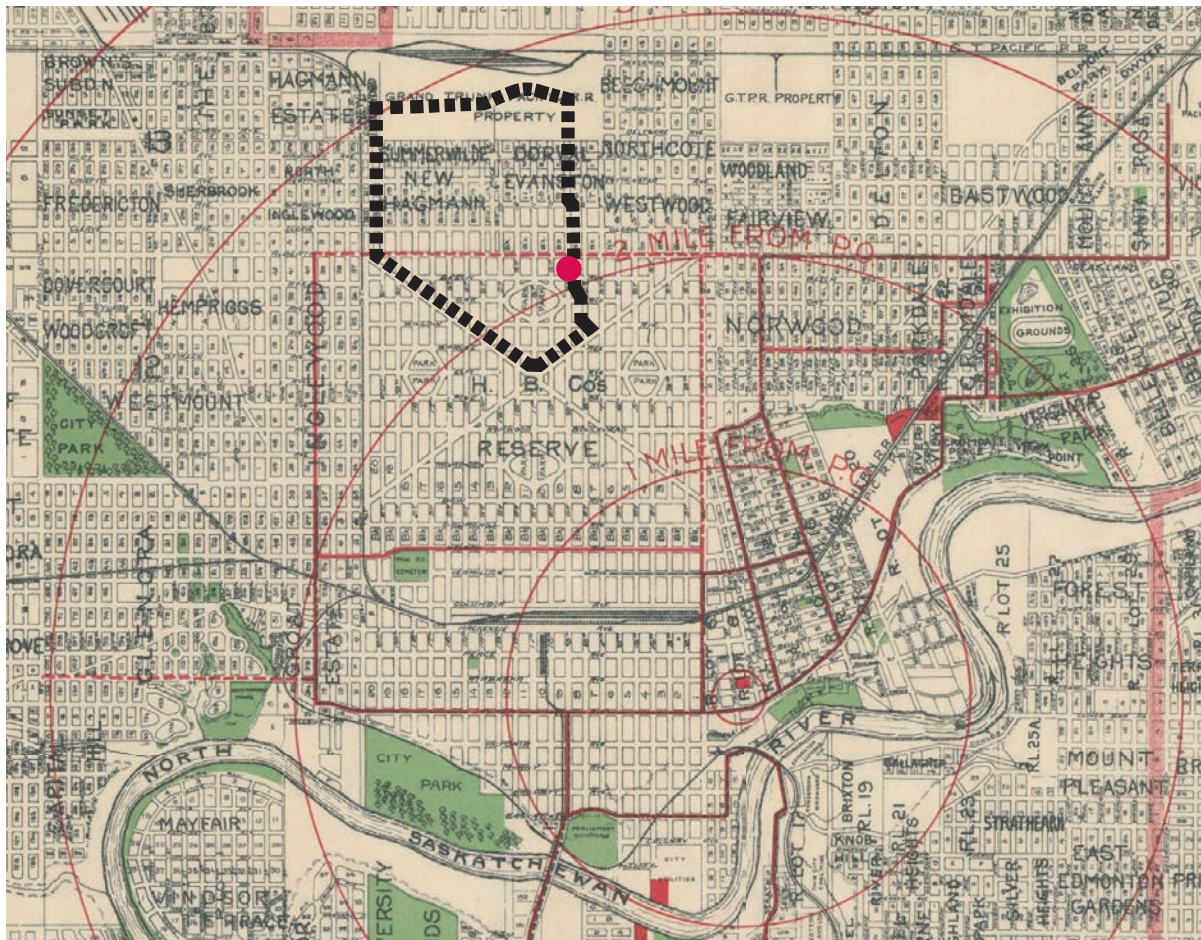

Mundy's 1913 map of Edmonton and suburbs. A dashed black outline of the former Edmonton Municipal Airport field is shown as it currently exists, with the location of Hangar 11 indicated with a red dot. Note that the proposed subdivided lands and streets within the future airport lot were not implemented. (Peel's Prairie Provinces, annotated by ERA).

Homesteading and Estates on the Outskirts of Edmonton

In 1881, the Dominion Lands Survey was used to divide several townships in Edmonton's vicinity. Townships featured a series of square sections, and each section was divided into quarters.

The Dominion Lands Act of 1872 provided settlers with 160-acre quarter-section homesteads, providing they build a residence on site, reside on the lands for at least three years, and cultivate a certain amount of land (generally 15 acres). Having met these conditions, the settler would receive the freehold title to the land.

In response in 1878, settlers began to claim lands on the outskirts of Edmonton, sustaining themselves with agriculture. Meanwhile, the nearby communities of Edmonton and Strathcona (on either side

of the North Saskatchewan River) were beginning to expand. The Hangar 11 property was located within the Hudson's Bay Company reserve, exempt from settler claims.

Strathcona and Edmonton, then separate communities on either side of the North Saskatchewan River, grew dramatically through the late 1890s and early 1900s in response to a wave of settler arrivals. They would ultimately amalgamate in 1912, seven years after the Province of Alberta was established and the city of Edmonton selected as its capital. Edmonton began to emerge as a service centre for the surrounding agricultural region that was in the process of being settled and cultivated.

Hangar 11 was located on the outskirts of the growing city of Edmonton, still at the north end of the Hudson's Bay Company reserve lands. It was surrounded by farm estates beginning to be marked for subdivision, including the Hagmann and New Hagmann Estates, Summerwilde, Dorval, Westwood, and North Inglewood.

Following the amalgamation of Edmonton and Strathcona in 1912, the city experienced a real estate boom, manifesting in the development of subdivision plans for estates and farmlands beyond the city boundaries. While lots were subdivided and offered for sale on paper, very few were physically subdivided and developed before the onset of World War One ultimately ended the city's real estate explosion.